

VIPA System SLIO

IM | 053-1ML00 | Manual

HB300 | IM | 053-1ML00 | en | 18-42

Interface module MECHATROLINK-III - IM 053ML



VIPA GmbH
Ohmstr. 4
91074 Herzogenaurach
Telephone: +49 9132 744-0
Fax: +49 9132 744-1864
Email: info@vipa.com
Internet: www.vipa.com

Table of contents

1	General	5
	1.1 Copyright © VIPA GmbH	5
	1.2 About this manual.....	6
	1.3 Safety information.....	7
2	Basics and mounting	8
	2.1 Safety information for users.....	8
	2.2 System conception.....	9
	2.2.1 Overview.....	9
	2.2.2 Components.....	10
	2.2.3 Accessories.....	12
	2.3 Dimensions.....	13
	2.4 Mounting bus coupler.....	15
	2.5 Wiring.....	17
	2.5.1 Wiring bus coupler.....	17
	2.5.2 Wiring periphery modules.....	20
	2.5.3 Wiring power modules.....	22
	2.6 Demounting.....	26
	2.6.1 Demounting bus coupler.....	26
	2.6.2 Demounting periphery modules.....	28
	2.7 Trouble shooting - LEDs.....	31
	2.8 Installation guidelines.....	32
	2.9 General data.....	34
3	Hardware description	36
	3.1 Properties.....	36
	3.2 Structure.....	37
	3.2.1 Interfaces.....	37
	3.2.2 LEDs.....	38
	3.2.3 Address switch.....	40
	3.3 Technical data.....	41
4	Deployment	44
	4.1 Basics MECHATROLINK-III.....	44
	4.2 MECHATROLINK-III installation guidelines.....	45
	4.2.1 Topology.....	45
	4.3 Accessing the System SLIO.....	47
	4.3.1 Supported modules.....	47
	4.3.2 Overview.....	49
	4.3.3 Example.....	50
	4.4 Communication with the MECHATROLINK-III master	51
	4.5 I/O area of the IM 053ML.....	52
	4.6 Web server.....	54
	4.7 Virtual memory.....	57
	4.8 Alarms and warnings.....	62
	4.9 MECHATROLINK-III specification.....	65
	4.9.1 Phases of the communication.....	65
	4.9.2 Standard IO profile.....	67
	4.9.3 ID information acquisition profile.....	72
	4.9.4 Command detail.....	73

4.9.5	MECHATROLINK message communication sub functions.....	84
4.9.6	Command sequence.....	86
4.10	Sample application.....	87
4.10.1	Overview.....	87
4.10.2	Sequence of coupler commands.....	89
4.10.3	Communication structure.....	90
	Appendix	91
A	History of changes.....	93

1 General

1.1 Copyright © VIPA GmbH

All Rights Reserved

This document contains proprietary information of VIPA and is not to be disclosed or used except in accordance with applicable agreements.

This material is protected by the copyright laws. It may not be reproduced, distributed, or altered in any fashion by any entity (either internal or external to VIPA), except in accordance with applicable agreements, contracts or licensing, without the express written consent of VIPA and the business management owner of the material.

For permission to reproduce or distribute, please contact: VIPA, Gesellschaft für Visualisierung und Prozessautomatisierung mbH Ohmstraße 4, D-91074 Herzogenaurach, Germany

Tel.: +49 9132 744 -0

Fax.: +49 9132 744-1864

E-Mail: info@vipa.de

<http://www.vipa.com>



Every effort has been made to ensure that the information contained in this document was complete and accurate at the time of publishing. Nevertheless, the authors retain the right to modify the information.

This customer document describes all the hardware units and functions known at the present time. Descriptions may be included for units which are not present at the customer site. The exact scope of delivery is described in the respective purchase contract.

CE Conformity Declaration

Hereby, VIPA GmbH declares that the products and systems are in compliance with the essential requirements and other relevant provisions. Conformity is indicated by the CE marking affixed to the product.

Conformity Information

For more information regarding CE marking and Declaration of Conformity (DoC), please contact your local VIPA customer service organization.

Trademarks

VIPA, SLIO, System 100V, System 200V, System 300V, System 300S, System 400V, System 500S and Commander Compact are registered trademarks of VIPA Gesellschaft für Visualisierung und Prozessautomatisierung mbH.

SPEED7 is a registered trademark of profichip GmbH.

SIMATIC, STEP, SINEC, TIA Portal, S7-300, S7-400 and S7-1500 are registered trademarks of Siemens AG.

Microsoft and Windows are registered trademarks of Microsoft Inc., USA.

Portable Document Format (PDF) and Postscript are registered trademarks of Adobe Systems, Inc.

All other trademarks, logos and service or product marks specified herein are owned by their respective companies.

Information product support

Contact your local VIPA Customer Service Organization representative if you wish to report errors or questions regarding the contents of this document. If you are unable to locate a customer service centre, contact VIPA as follows:

VIPA GmbH, Ohmstraße 4, 91074 Herzogenaurach, Germany

Telefax: +49 9132 744-1204

E-Mail: documentation@vipa.de

Technical support

Contact your local VIPA Customer Service Organization representative if you encounter problems with the product or have questions regarding the product. If you are unable to locate a customer service centre, contact VIPA as follows:

VIPA GmbH, Ohmstraße 4, 91074 Herzogenaurach, Germany

Tel.: +49 9132 744-1150 (Hotline)

E-Mail: support@vipa.de

1.2 About this manual

Objective and contents

The manual describes the IM 053-1ML00 of the System SLIO from VIPA. It contains a description of the structure, project implementation and usage.

Product	Order no.	as of state:	
		HW	FW
IM 053ML	053-1ML00	01	V1.0.5

Target audience

The manual is targeted at users who have a background in automation technology.

Structure of the manual

The manual consists of chapters. Every chapter provides a self-contained description of a specific topic.

Guide to the document

The following guides are available in the manual:

- An overall table of contents at the beginning of the manual
- References with page numbers

Availability

The manual is available in:

- printed form, on paper
- in electronic form as PDF-file (Adobe Acrobat Reader)

Icons Headings

Important passages in the text are highlighted by following icons and headings:

**DANGER!**

Immediate or likely danger. Personal injury is possible.

**CAUTION!**

Damages to property is likely if these warnings are not heeded.



Supplementary information and useful tips.

1.3 Safety information

Applications conforming with specifications

The system is constructed and produced for:

- communication and process control
- general control and automation tasks
- industrial applications
- operation within the environmental conditions specified in the technical data
- installation into a cubicle

**DANGER!**

This device is not certified for applications in

- in explosive environments (EX-zone)

Documentation

The manual must be available to all personnel in the

- project design department
- installation department
- commissioning
- operation

**CAUTION!**

The following conditions must be met before using or commissioning the components described in this manual:

- Hardware modifications to the process control system should only be carried out when the system has been disconnected from power!
- Installation and hardware modifications only by properly trained personnel.
- The national rules and regulations of the respective country must be satisfied (installation, safety, EMC ...)

Disposal

National rules and regulations apply to the disposal of the unit!

2 Basics and mounting

2.1 Safety information for users

Handling of electrostatic sensitive modules

VIPA modules make use of highly integrated components in MOS-Technology. These components are extremely sensitive to over-voltages that can occur during electrostatic discharges. The following symbol is attached to modules that can be destroyed by electrostatic discharges.



The Symbol is located on the module, the module rack or on packing material and it indicates the presence of electrostatic sensitive equipment. It is possible that electrostatic sensitive equipment is destroyed by energies and voltages that are far less than the human threshold of perception. These voltages can occur where persons do not discharge themselves before handling electrostatic sensitive modules and they can damage components thereby, causing the module to become inoperable or unusable. Modules that have been damaged by electrostatic discharges can fail after a temperature change, mechanical shock or changes in the electrical load. Only the consequent implementation of protection devices and meticulous attention to the applicable rules and regulations for handling the respective equipment can prevent failures of electrostatic sensitive modules.

Shipping of modules

Modules must be shipped in the original packing material.

Measurements and alterations on electrostatic sensitive modules

When you are conducting measurements on electrostatic sensitive modules you should take the following precautions:

- Floating instruments must be discharged before use.
- Instruments must be grounded.

Modifying electrostatic sensitive modules you should only use soldering irons with grounded tips.



CAUTION!

Personnel and instruments should be grounded when working on electrostatic sensitive modules.

2.2 System conception

2.2.1 Overview

System SLIO is a modular automation system for assembly on a 35mm mounting rail. By means of the peripheral modules with 2, 4 or 8 channels this system may properly be adapted matching to your automation tasks. The wiring complexity is low, because the supply of the DC 24V power section is integrated to the backplane bus and defective modules may be replaced with standing wiring. By deployment of the power modules in contrasting colors within the system, further isolated areas may be defined for the DC 24V power section supply, respectively the electronic power supply may be extended with 2A.

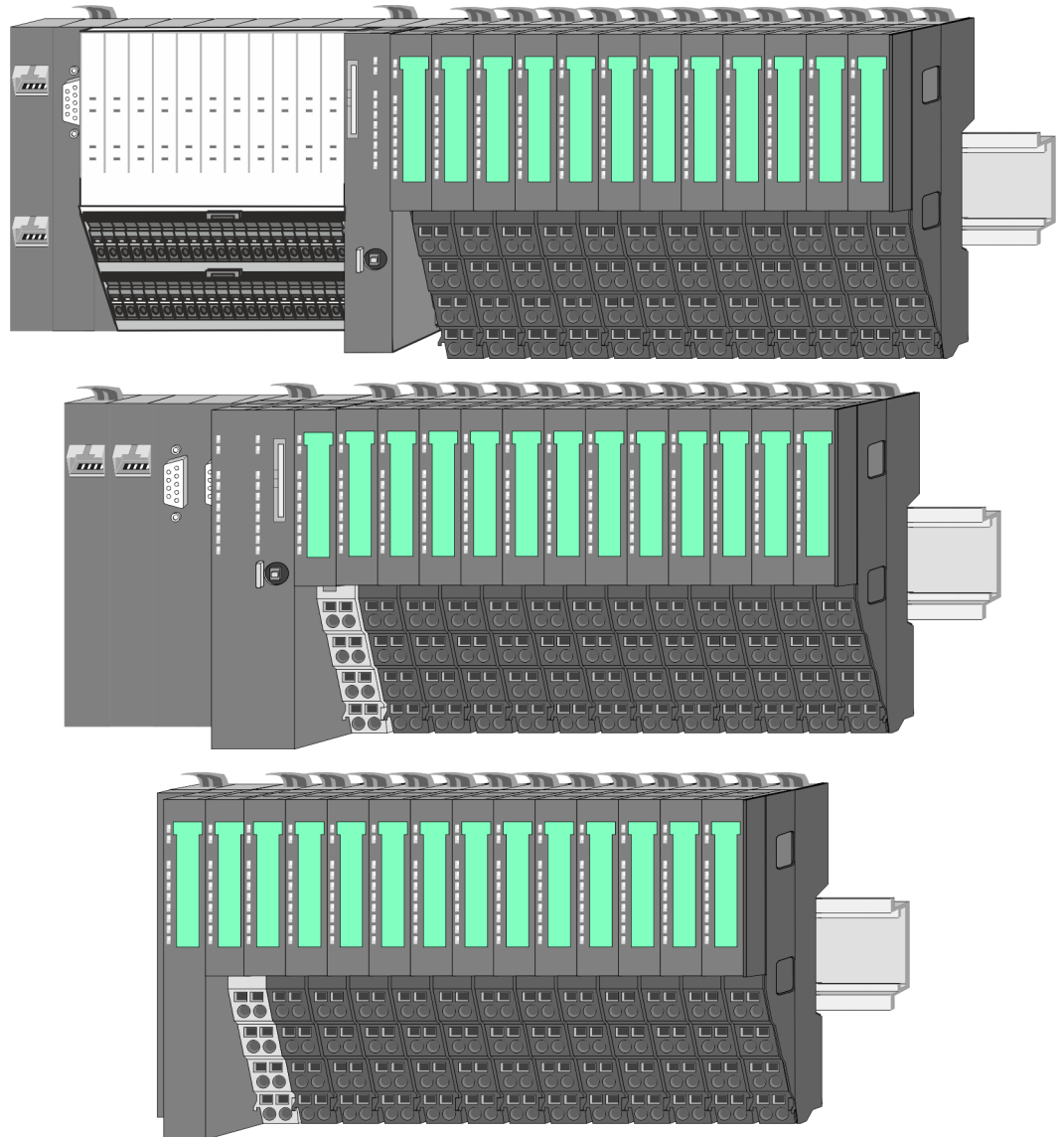

2.2.2 Components

- CPU (head module)
- Bus coupler (head module)
- Line extension
- Periphery modules
- Accessories



CAUTION!

Only modules of VIPA may be combined. A mixed operation with third-party modules is not allowed!

CPU 01xC

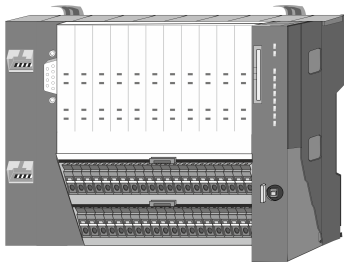

With this CPU 01xC, the CPU electronic, input/output components and power supply are integrated to one casing. In addition, up to 64 periphery modules of the System SLIO can be connected to the backplane bus. As head module via the integrated power supply CPU electronic and the I/O components are power supplied as well as the electronic of the connected periphery modules. To connect the power supply of the I/O components and for DC 24V power supply of via backplane bus connected peripheral modules, the CPU has removable connectors. By installing of up to 64 periphery modules at the backplane bus, these are electrically connected, this means these are assigned to the backplane bus, the electronic modules are power supplied and each periphery module is connected to the DC 24V power section supply.

CPU 01x



With this CPU 01x, the CPU electronic and power supply are integrated to one casing. As head module, via the integrated power module for power supply, CPU electronic and the electronic of the connected periphery modules are supplied. The DC 24 power section supply for the linked periphery modules is established via a further connection of the power module. By installing of up to 64 periphery modules at the backplane bus, these are electrically connected, this means these are assigned to the backplane bus, the electronic modules are power supplied and each periphery module is connected to the DC 24V power section supply.



CAUTION!

CPU part and power module may not be separated!
Here you may only exchange the electronic module!

Bus coupler

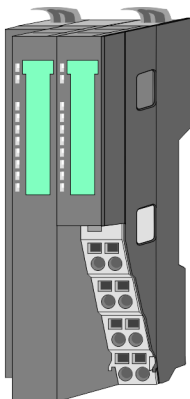

With a bus coupler bus interface and power module is integrated to one casing. With the bus interface you get access to a subordinated bus system. As head module, via the integrated power module for power supply, bus interface and the electronic of the connected periphery modules are supplied. The DC 24 power section supply for the linked periphery modules is established via a further connection of the power module. By installing of up to 64 periphery modules at the bus coupler, these are electrically connected, this means these are assigned to the backplane bus, the electronic modules are power supplied and each periphery module is connected to the DC 24V power section supply.



CAUTION!

Bus interface and power module may not be separated!
Here you may only exchange the electronic module!

Line extension

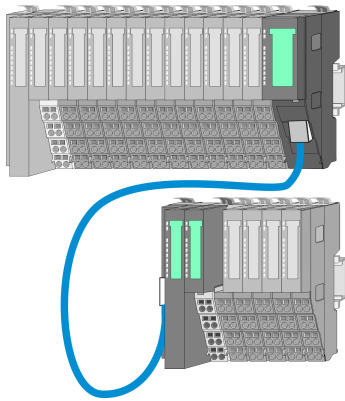

In the System SLIO there is the possibility to place up to 64 modules in on line. By means of the line extension you can divide this line into several lines. Here you have to place a line extension master at each end of a line and the subsequent line has to start with a line extension slave. Master and slave are to be connected via a special connecting cable. In this way, you can divide a line on up to 5 lines. For each line extension the maximum number of pluggable modules at the System SLIO bus is decreased by 1. To use the line extension no special configuration is required.

Periphery modules

Each periphery module consists of a *terminal* and an *electronic module*.

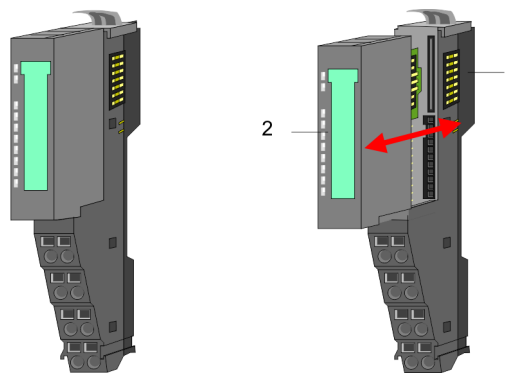

- 1 Terminal module
- 2 Electronic module

Terminal module

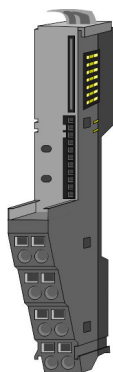

The *terminal* module serves to carry the electronic module, contains the backplane bus with power supply for the electronic, the DC 24V power section supply and the staircase-shaped terminal for wiring. Additionally the terminal module has a locking system for fixing at a mounting rail. By means of this locking system your SLIO system may be assembled outside of your switchgear cabinet to be later mounted there as whole system.

Electronic module

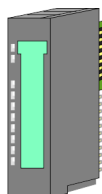

The functionality of a SLIO periphery module is defined by the *electronic* module, which is mounted to the terminal module by a sliding mechanism. With an error the defective module may be exchanged for a functional module with standing installation. At the front side there are LEDs for status indication. For simple wiring each module shows a corresponding connection diagram at the front and at the side.

2.2.3 Accessories

Shield bus carrier



The shield bus carrier (order no.: 000-0AB00) serves to carry the shield bus (10mm x 3mm) to connect cable shields. Shield bus carriers, shield bus and shield fixings are not in the scope of delivery. They are only available as accessories. The shield bus carrier is mounted underneath the terminal of the terminal module. With a flat mounting rail for adaptation to a flat mounting rail you may remove the spacer of the shield bus carrier.

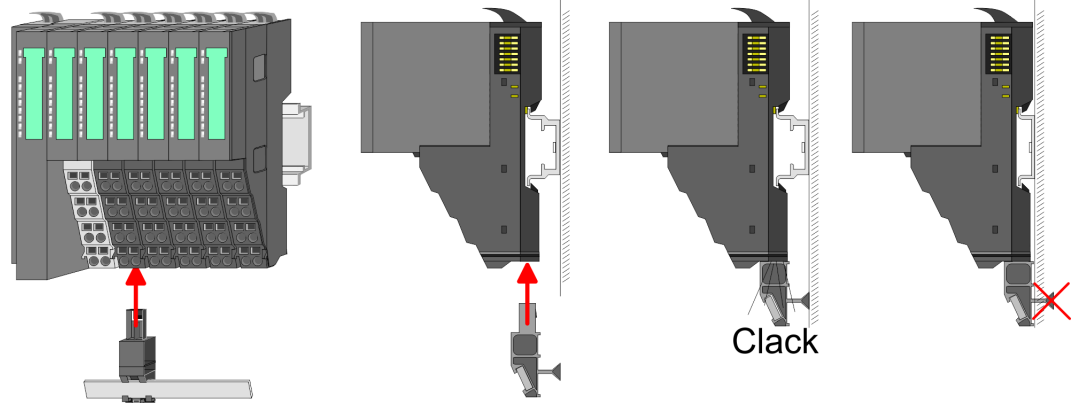

Bus cover

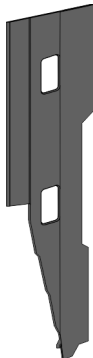

With each head module, to protect the backplane bus connectors, there is a mounted bus cover in the scope of delivery. You have to remove the bus cover of the head module before mounting a System SLIO module. For the protection of the backplane bus connector you always have to mount the bus cover at the last module of your system again. The bus cover has the order no. 000-0AA00.

Coding pins



There is the possibility to fix the assignment of electronic and terminal module. Here coding pins (order number 000-0AC00) from VIPA can be used. The coding pin consists of a coding jack and a coding plug. By combining electronic and terminal module with coding pin, the coding jack remains in the electronic module and the coding plug in the terminal module. This ensures that after replacing the electronics module just another electronic module can be plugged with the same encoding.

2.3 Dimensions

Dimensions CPU 01xC

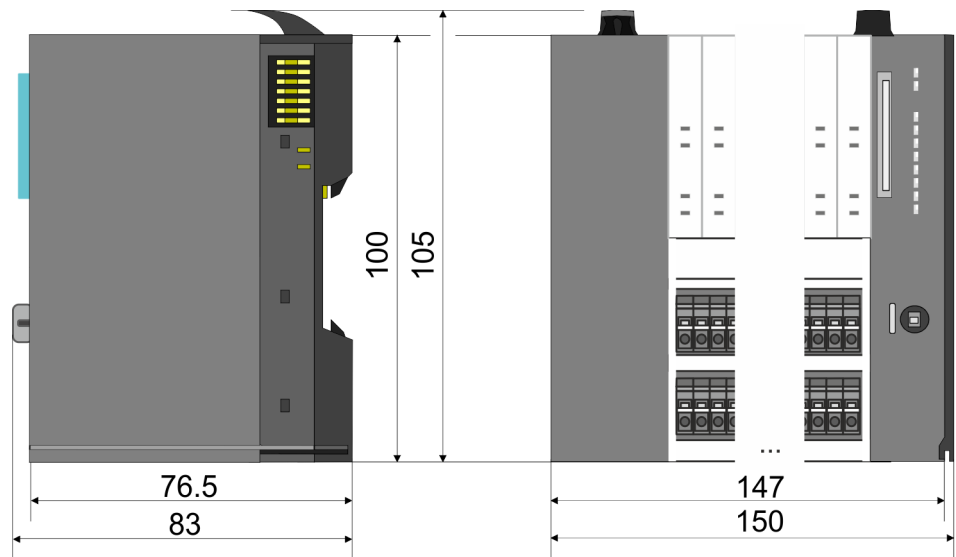

Dimensions CPU 01x

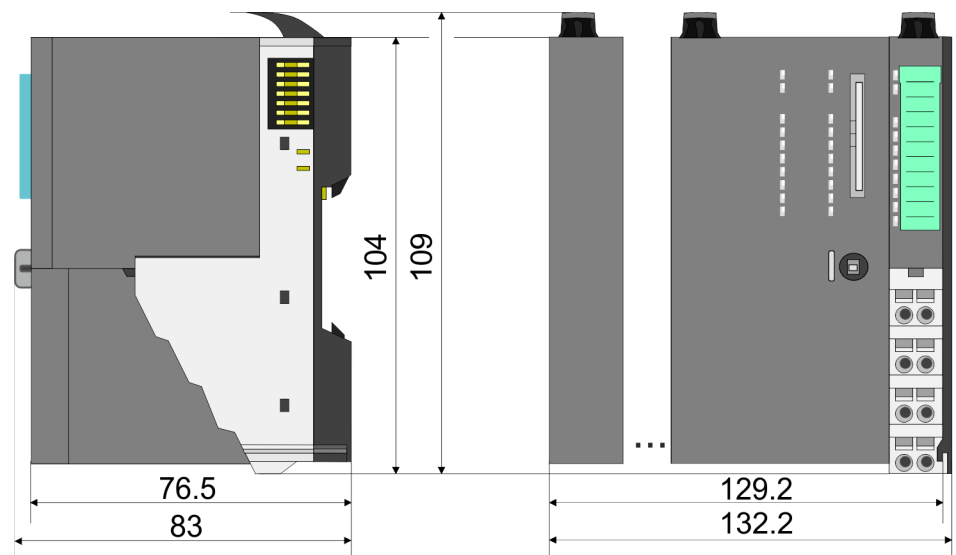

Dimensions bus coupler and line extension slave

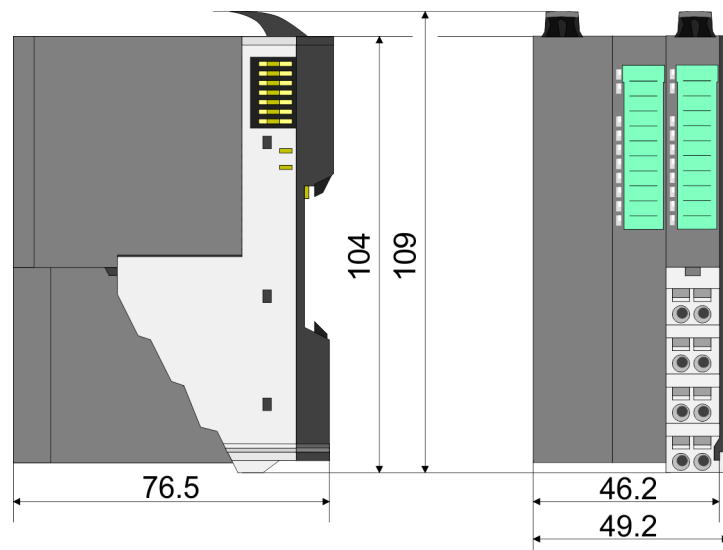

Dimensions

Dimensions line extension master

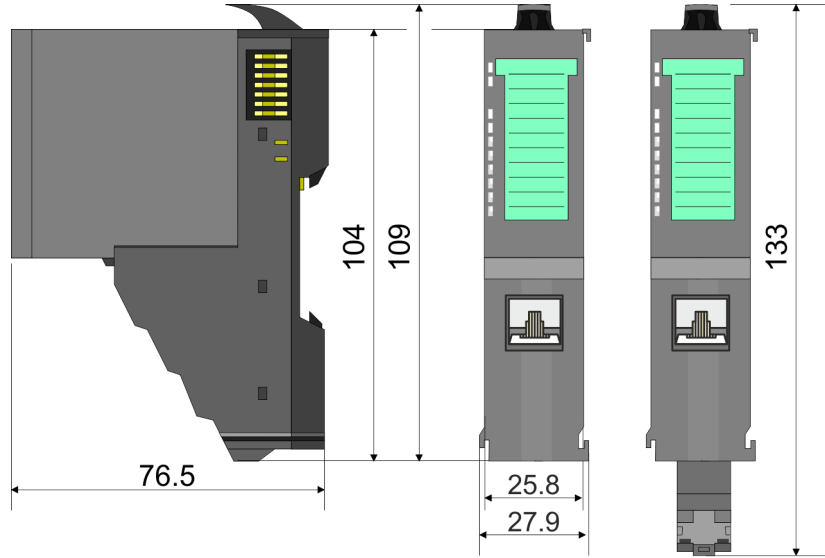

Dimension periphery module

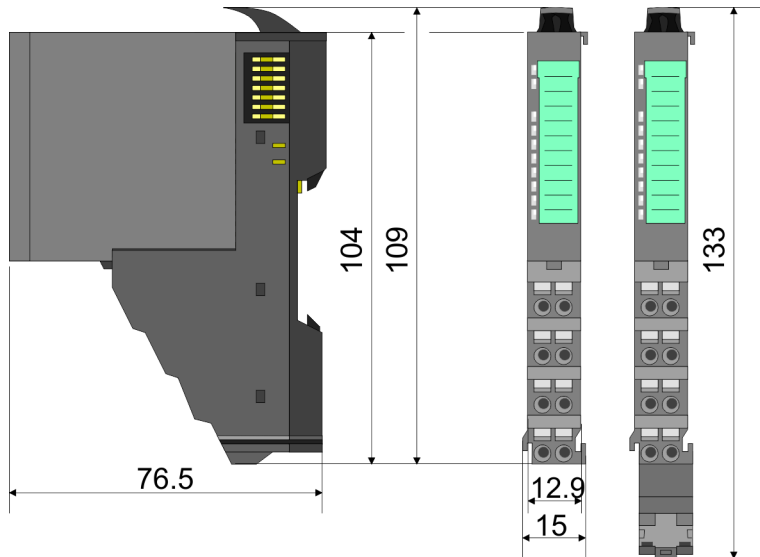

Dimensions electronic module

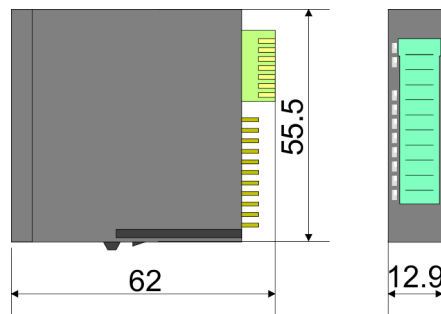

Dimensions in mm

2.4 Mounting bus coupler



Requirements for UL compliance use

- Use for power supply exclusively SELV/PELV power supplies.
- The System SLIO must be installed and operated in a housing according to IEC 61010-1 9.3.2 c).

There are locking lever at the top side of the bus coupler. For mounting and demounting these locking lever are to be turned upwards until these engage. Place the bus coupler at the mounting rail. The bus coupler is fixed to the mounting rail by pushing downward the locking levers. The bus coupler is directly mounted at a mounting rail. Up to 64 modules may be mounted. The electronic and power section supply are connected via the back-plane bus. Please consider here that the sum current of the electronic power supply does not exceed the maximum value of 3A. By means of the power module 007-1AB10 the current of the electronic power supply may be expanded accordingly.

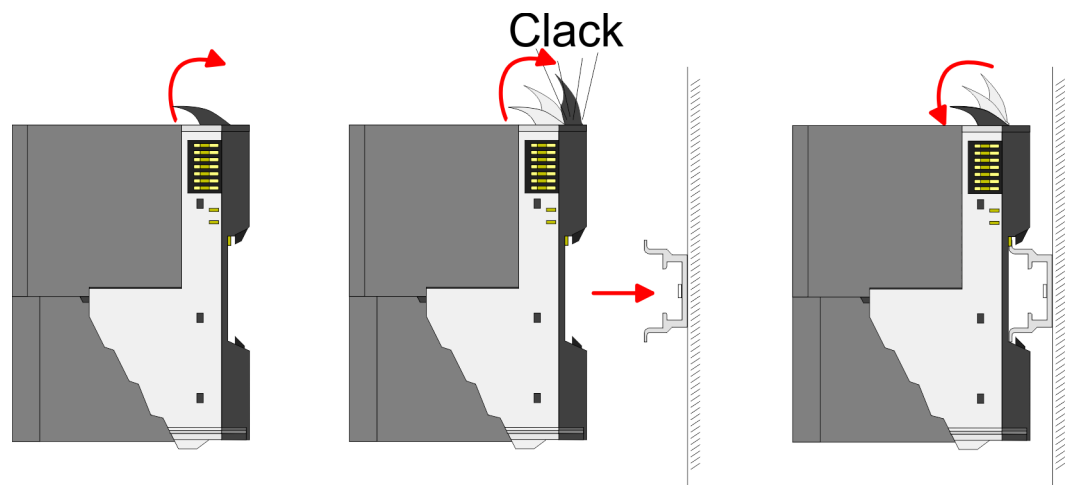

Proceeding



1. → Mount the mounting rail! Please consider that a clearance from the middle of the mounting rail of at least 80mm above and 60mm below, respectively 80mm by deployment of shield bus carriers, exist.

Mounting bus coupler

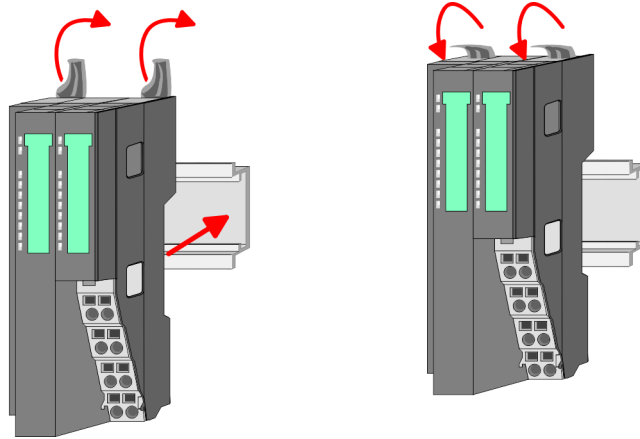

2. Turn the locking lever upwards, place the bus coupler at the mounting rail and turn the lever downward.

Mounting periphery modules

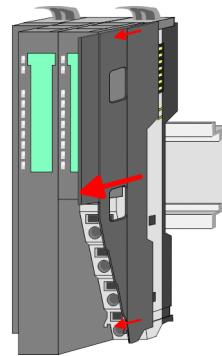

1. Before mounting the periphery modules you have to remove the bus cover at the right side of the bus coupler by pulling it forward. Keep the cover for later mounting.

Clack

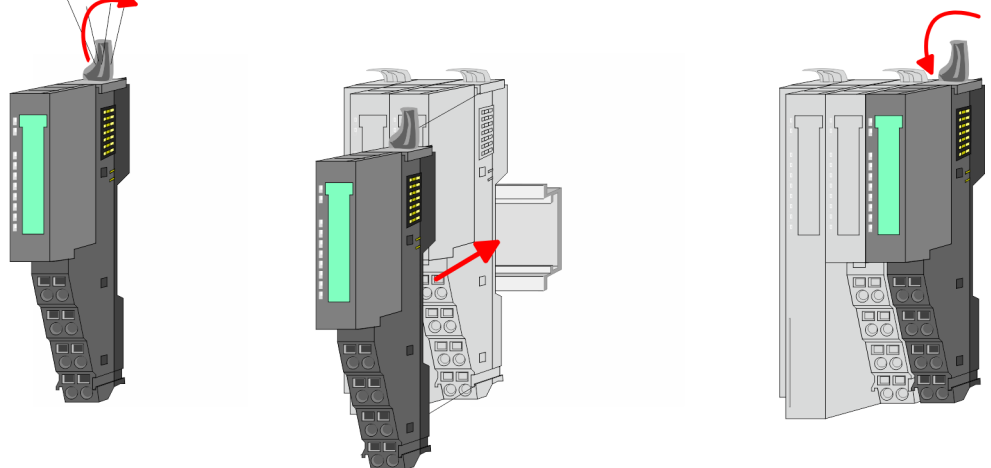

2. Mount the periphery modules you want.

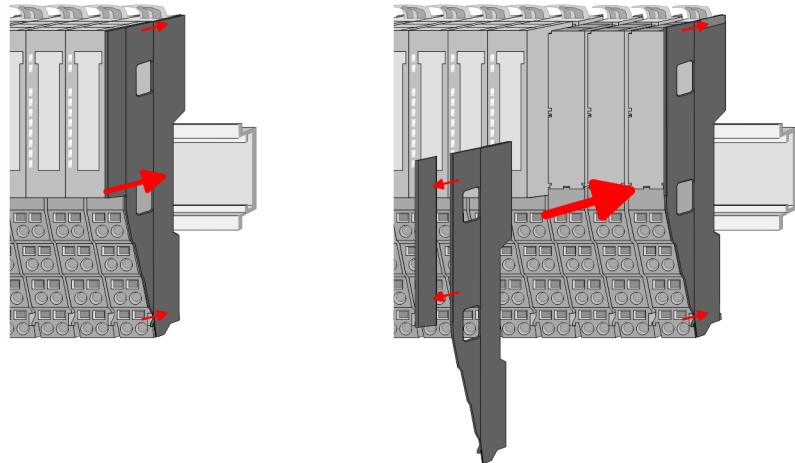

3. After mounting the whole system, to protect the backplane bus connectors at the last module you have to mount the bus cover, now. If the last module is a clamp module, for adaptation the upper part of the bus cover is to be removed.

2.5 Wiring



CAUTION!

Consider temperature for external cables!

Cables may experience temperature increase due to system heat dissipation. Thus the cabling specification must be chosen 5°C above ambient temperature!



CAUTION!

Separate insulation areas!

The system is specified for SELV/PELV environment. Devices, which are attached to the system must meet these specifications. Installation and cable routing other than SELV/PELV specification must be separated from the system's equipment!

2.5.1 Wiring bus coupler

Terminal module terminals

The System SLIO bus coupler have a power module integrated. Terminals with spring clamp technology are used for wiring. The spring clamp technology allows quick and easy connection of your signal and supply lines. In contrast to screw terminal connections this type of connection is vibration proof.

Data

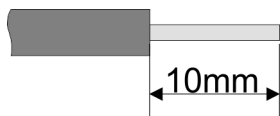

U_{max}	30V DC
I_{max}	10A
Cross section	0.08 ... 1.5mm ² (AWG 28 ... 16)
Stripping length	10mm

Wiring procedure

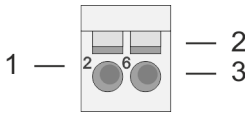

- 1 Pin number at the connector
- 2 Opening for screwdriver
- 3 Connection hole for wire

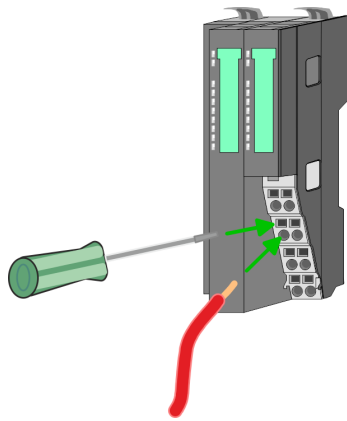
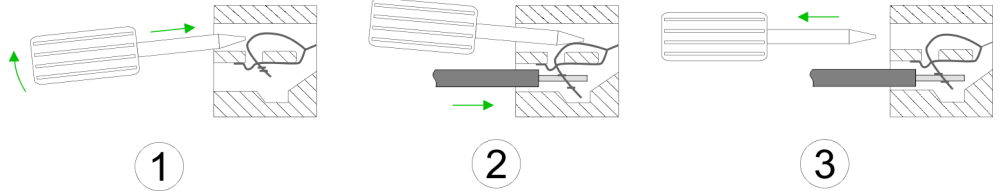

- 1. Insert a suited screwdriver at an angle into the square opening as shown. Press and hold the screwdriver in the opposite direction to open the contact spring.
- 2. Insert the stripped end of wire into the round opening. You can use wires with a cross section of 0.08mm² up to 1.5mm²
- 3. By removing the screwdriver, the wire is securely fixed via the spring contact to the terminal.

Standard wiring

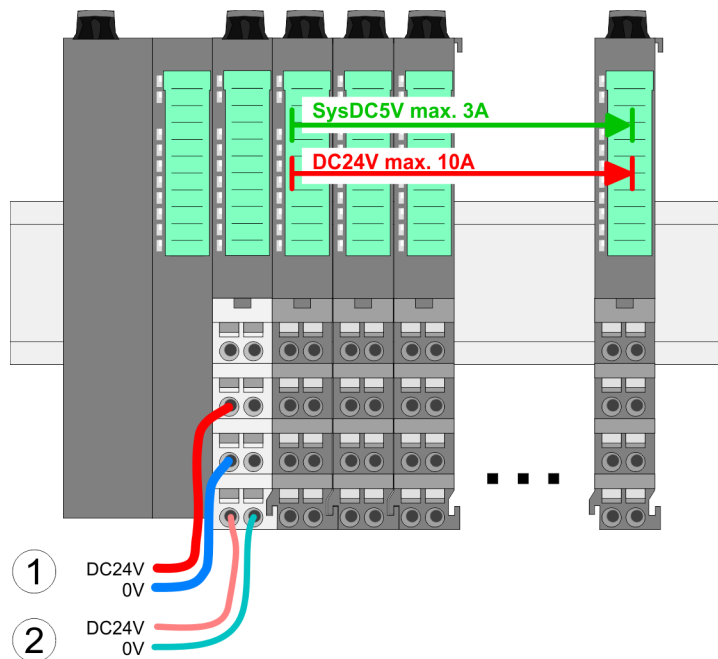

- (1) DC 24V for power section supply I/O area (max. 10A)
- (2) DC 24V for electronic power supply bus coupler and I/O area

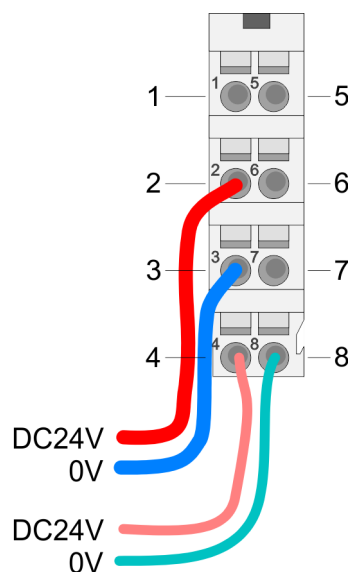
PM - Power module

For wires with a core cross-section of 0.08mm² up to 1.5mm².

Pos.	Function	Type	Description
1	---	---	not connected
2	DC 24V	I	DC 24V for power section supply
3	0V	I	GND for power section supply
4	Sys DC 24V	I	DC 24V for electronic section supply
5	---	---	not connected
6	DC 24V	I	DC 24V for power section supply
7	0V	I	GND for power section supply
8	Sys 0V	I	GND for electronic section supply

I: Input

**CAUTION!**

Since the power section supply is not internally protected, it is to be externally protected with a fuse, which corresponds to the maximum current. This means max. 10A is to be protected by a 10A fuse (fast) respectively by a line circuit breaker 10A characteristics Z!



The electronic power section supply is internally protected against higher voltage by fuse. The fuse is within the power module. If the fuse releases, its electronic module must be exchanged!

Fusing

- The power section supply is to be externally protected with a fuse, which corresponds to the maximum current. This means max. 10A is to be protected with a 10A fuse (fast) respectively by a line circuit breaker 10A characteristics Z!
- It is recommended to externally protect the electronic power supply for bus coupler and I/O area with a 2A fuse (fast) respectively by a line circuit breaker 2A characteristics Z.
- The electronic power supply for the I/O area of the power module 007-1AB10 should also be externally protected with a 1A fuse (fast) respectively by a line circuit breaker 1A characteristics Z.

State of the electronic power supply via LEDs

After PowerON of the System SLIO the LEDs RUN respectively MF get on so far as the sum current does not exceed 3A. With a sum current greater than 3A the LEDs may not be activated. Here the power module with the order number 007-1AB10 is to be placed between the peripheral modules.

Shield attachment

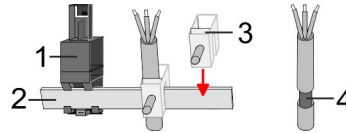

- 1 Shield bus carrier
- 2 Shield bus (10mm x 3mm)
- 3 Shield clamp
- 4 Cable shield

To attach the shield the mounting of shield bus carriers are necessary. The shield bus carrier (available as accessory) serves to carry the shield bus to connect cable shields.

1. ➤ Each System SLIO module has a carrier hole for the shield bus carrier. Push the shield bus carrier, until they engage into the module. With a flat mounting rail for adaptation to a flat mounting rail you may remove the spacer of the shield bus carrier.
2. ➤ Put your shield bus into the shield bus carrier.

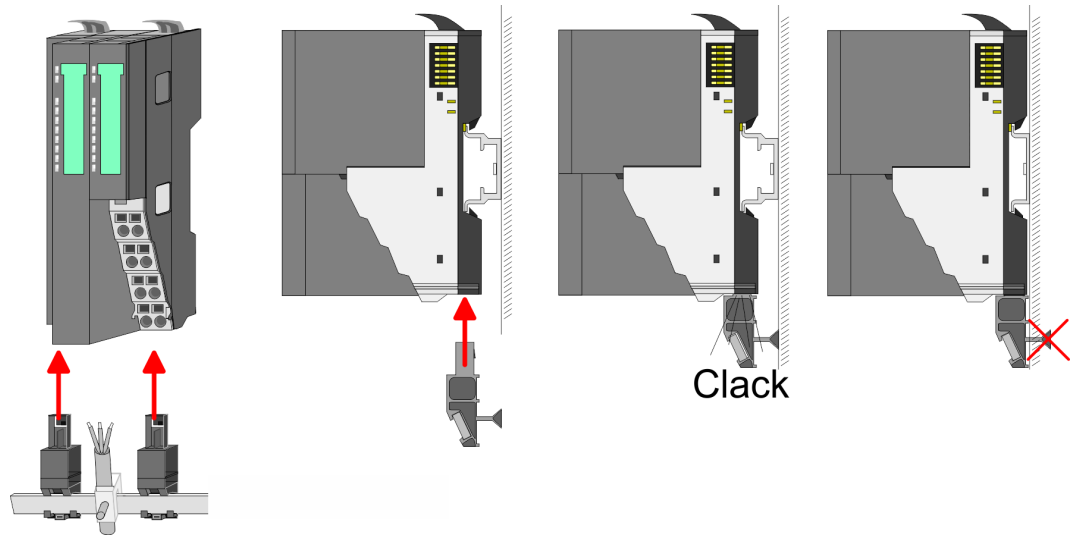

3. ➤ Attach the cables with the accordingly stripped cable screen and fix it by the shield clamp with the shield bus.

2.5.2 Wiring periphery modules

Terminal module terminals



CAUTION!

Do not connect hazardous voltages!

If this is not explicitly stated in the corresponding module description, hazardous voltages are not allowed to be connected to the corresponding terminal module!

With wiring the terminal modules, terminals with spring clamp technology are used for wiring. The spring clamp technology allows quick and easy connection of your signal and supply lines. In contrast to screw terminal connections this type of connection is vibration proof.

Data

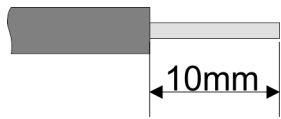

U_{max} 240V AC / 30V DC
 I_{max} 10A
 Cross section 0.08 ... 1.5mm² (AWG 28 ... 16)
 Stripping length 10mm

Wiring procedure

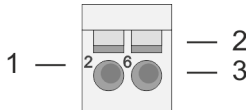

- 1 Pin number at the connector
- 2 Opening for screwdriver
- 3 Connection hole for wire

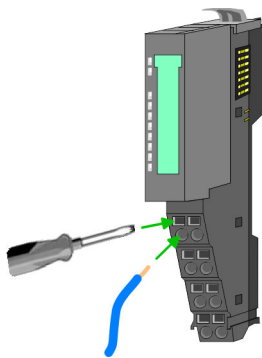
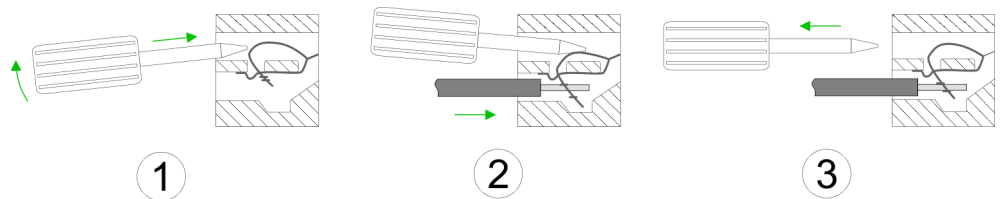

1. Insert a suited screwdriver at an angle into the square opening as shown. Press and hold the screwdriver in the opposite direction to open the contact spring.
2. Insert the stripped end of wire into the round opening. You can use wires with a cross section of 0.08mm² up to 1.5mm²
3. By removing the screwdriver, the wire is securely fixed via the spring contact to the terminal.

Shield attachment

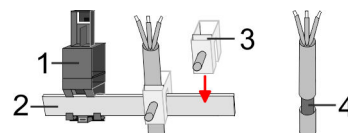

- 1 Shield bus carrier
- 2 Shield bus (10mm x 3mm)
- 3 Shield clamp
- 4 Cable shield

To attach the shield the mounting of shield bus carriers are necessary. The shield bus carrier (available as accessory) serves to carry the shield bus to connect cable shields.

1. Each System SLIO module has a carrier hole for the shield bus carrier. Push the shield bus carrier, until they engage into the module. With a flat mounting rail for adaptation to a flat mounting rail you may remove the spacer of the shield bus carrier.
2. Put your shield bus into the shield bus carrier.

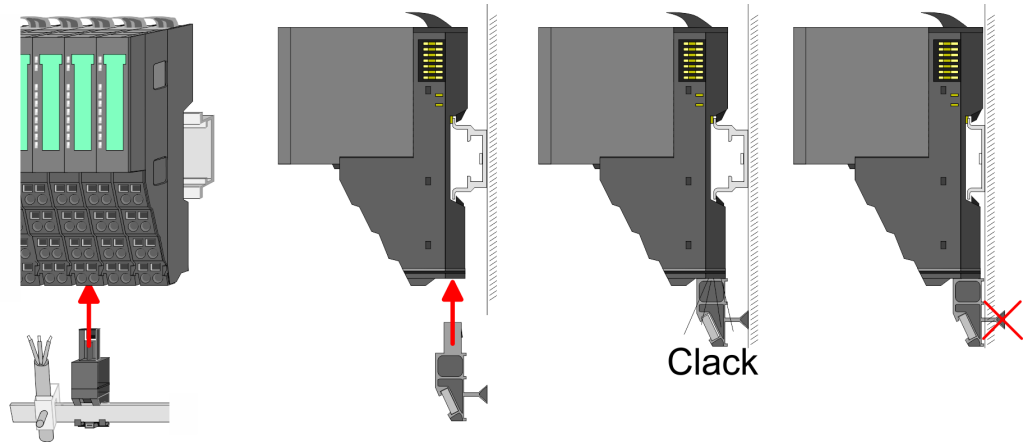

3. Attach the cables with the accordingly stripped cable screen and fix it by the shield clamp with the shield bus.

2.5.3 Wiring power modules

Terminal module terminals

Power modules are either integrated to the head module or may be installed between the periphery modules. With power modules, terminals with spring clamp technology are used for wiring. The spring clamp technology allows quick and easy connection of your signal and supply lines. In contrast to screw terminal connections this type of connection is vibration proof.

Data

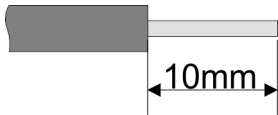

U_{max}	30V DC
I_{max}	10A
Cross section	0.08 ... 1.5mm ² (AWG 28 ... 16)
Stripping length	10mm

Wiring procedure

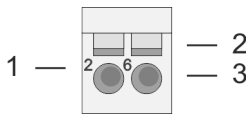

- 1 Pin number at the connector
- 2 Opening for screwdriver
- 3 Connection hole for wire

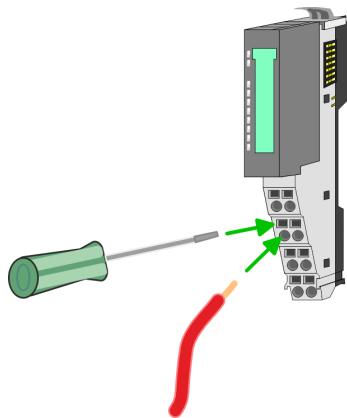
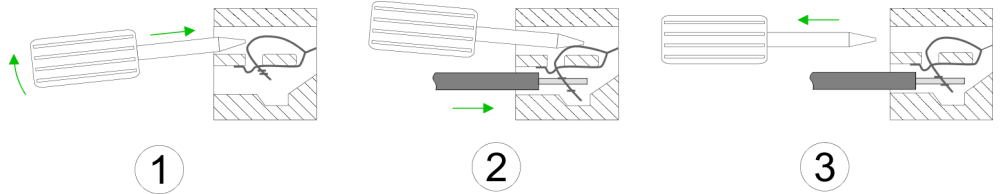

- 1. Insert a suited screwdriver at an angle into the square opening as shown. Press and hold the screwdriver in the opposite direction to open the contact spring.
- 2. Insert the stripped end of wire into the round opening. You can use wires with a cross section of 0.08mm² up to 1.5mm²
- 3. By removing the screwdriver, the wire is securely fixed via the spring contact to the terminal.

Standard wiring

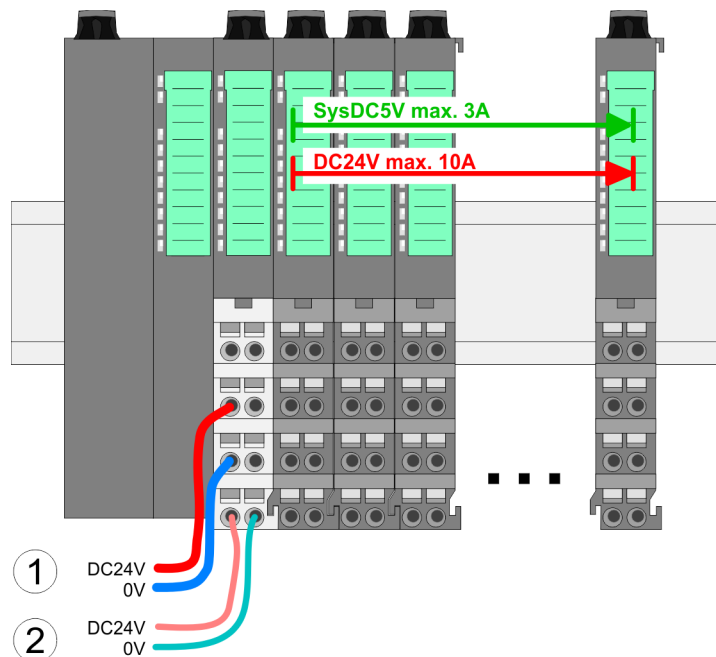

- (1) DC 24V for power section supply I/O area (max. 10A)
- (2) DC 24V for electronic power supply bus coupler and I/O area

PM - Power module

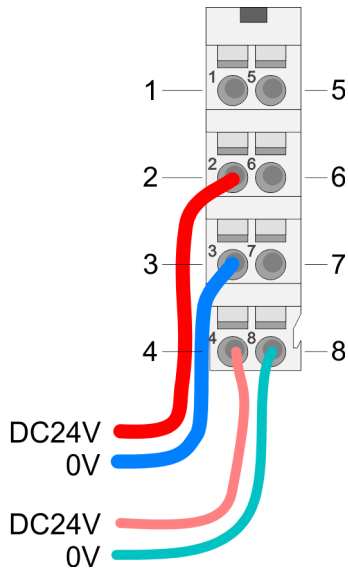

For wires with a core cross-section of 0.08mm² up to 1.5mm².

Pos.	Function	Type	Description
1	---	---	not connected
2	DC 24V	I	DC 24V for power section supply
3	0V	I	GND for power section supply
4	Sys DC 24V	I	DC 24V for electronic section supply
5	---	---	not connected
6	DC 24V	I	DC 24V for power section supply
7	0V	I	GND for power section supply
8	Sys 0V	I	GND for electronic section supply

I: Input



CAUTION!

Since the power section supply is not internally protected, it is to be externally protected with a fuse, which corresponds to the maximum current. This means max. 10A is to be protected by a 10A fuse (fast) respectively by a line circuit breaker 10A characteristics Z!



The electronic power section supply is internally protected against higher voltage by fuse. The fuse is within the power module. If the fuse releases, its electronic module must be exchanged!

Fusing

- The power section supply is to be externally protected with a fuse, which corresponds to the maximum current. This means max. 10A is to be protected with a 10A fuse (fast) respectively by a line circuit breaker 10A characteristics Z!
- It is recommended to externally protect the electronic power supply for head modules and I/O area with a 2A fuse (fast) respectively by a line circuit breaker 2A characteristics Z.
- The electronic power supply for the I/O area of the power module 007-1AB10 should also be externally protected with a 1A fuse (fast) respectively by a line circuit breaker 1A characteristics Z.

State of the electronic power supply via LEDs

After PowerON of the System SLIO the LEDs RUN respectively MF get on so far as the sum current does not exceed 3A. With a sum current greater than 3A the LEDs may not be activated. Here the power module with the order number 007-1AB10 is to be placed between the peripheral modules.

Deployment of the power modules

- If the 10A for the power section supply is no longer sufficient, you may use the power module from VIPA with the order number 007-1AB00. So you have also the possibility to define isolated groups.
- The power module with the order number 007-1AB10 is to be used if the 3A for the electronic power supply at the backplane bus is no longer sufficient. Additionally you get an isolated group for the DC 24V power section supply with max. 4A.
- By placing the power module 007-1AB10 at the following backplane bus modules may be placed with a sum current of max. 2A. Afterwards a power module is to be placed again. To secure the power supply, the power modules may be mixed used.

Power module 007-1AB00

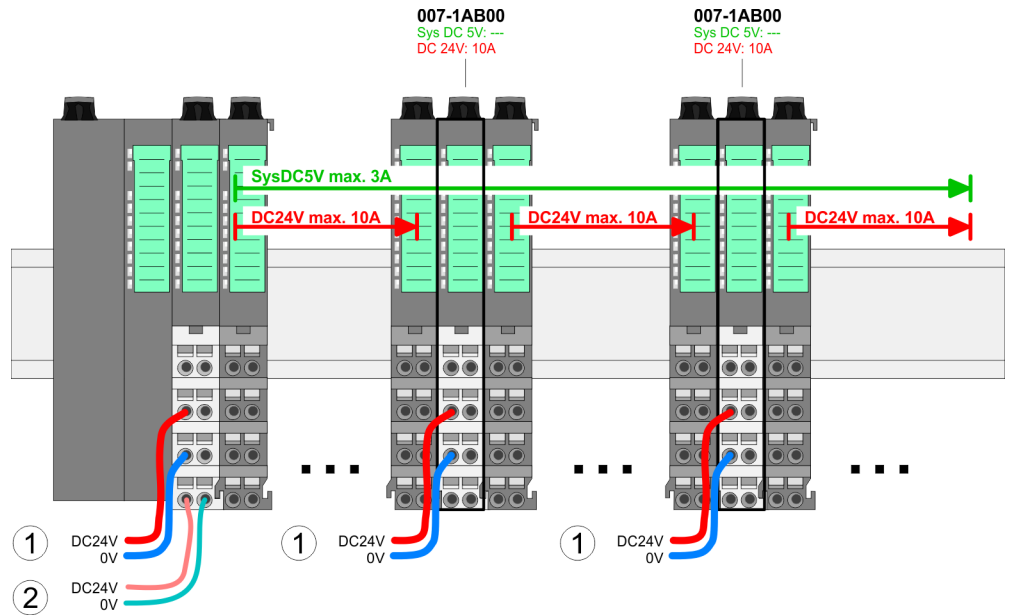

Power module 007-1AB10

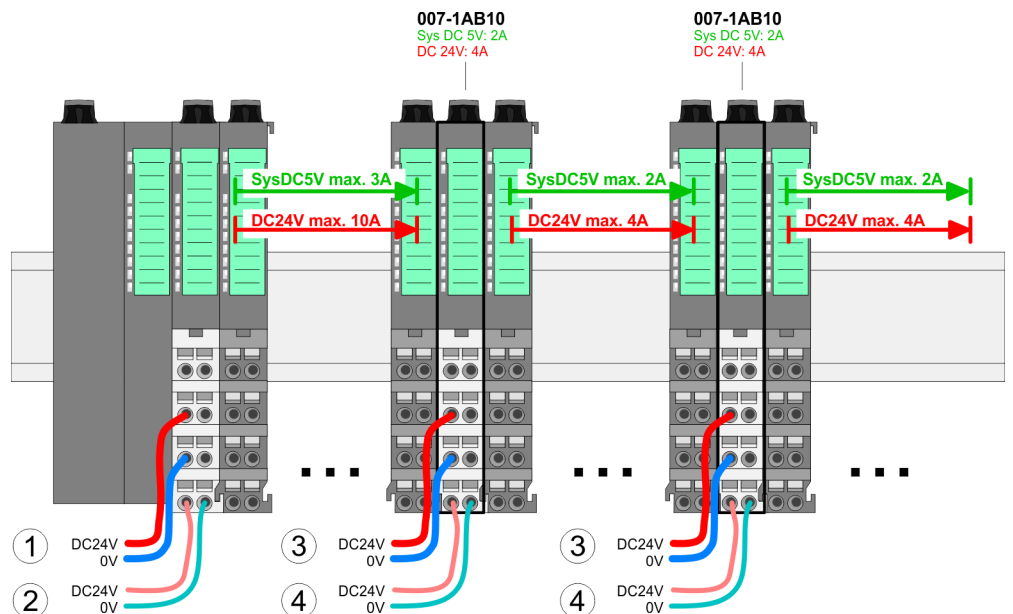

- (1) DC 24V for power section supply I/O area (max. 10A)
- (2) DC 24V for electronic power supply bus coupler and I/O area
- (3) DC 24V for power section supply I/O area (max. 4A)
- (4) DC 24V for electronic power supply I/O area

Shield attachment

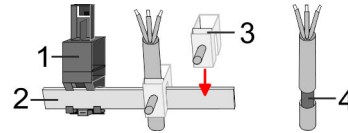

- 1 Shield bus carrier
- 2 Shield bus (10mm x 3mm)
- 3 Shield clamp
- 4 Cable shield

To attach the shield the mounting of shield bus carriers are necessary. The shield bus carrier (available as accessory) serves to carry the shield bus to connect cable shields.

- 1. Each System SLIO module has a carrier hole for the shield bus carrier. Push the shield bus carrier, until they engage into the module. With a flat mounting rail for adaptation to a flat mounting rail you may remove the spacer of the shield bus carrier.
- 2. Put your shield bus into the shield bus carrier.

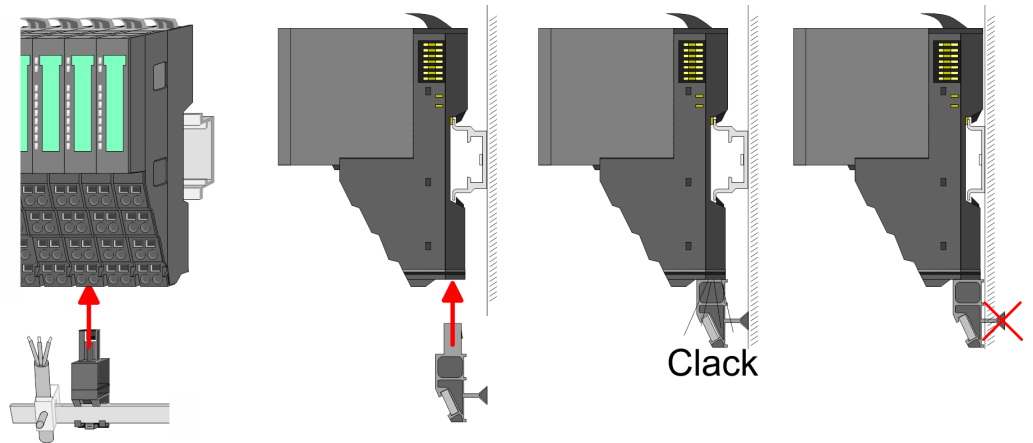

- 3. Attach the cables with the accordingly stripped cable screen and fix it by the shield clamp with the shield bus.

2.6 Demounting

2.6.1 Demounting bus coupler

Proceeding

CAUTION!
 Bus interface and power module may not be separated! Here you may only exchange the electronic module!

- 1. Power-off your system.
- 2. Remove if exists the wiring of the bus coupler.

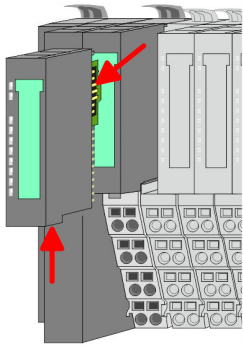

3. ➤



For demounting and exchange of a (head) module or a group of modules, due to mounting reasons you always have to remove the electronic module right beside. After mounting it may be plugged again.

Press the unlocking lever at the lower side of the just mounted right module near the bus coupler and pull it forward.

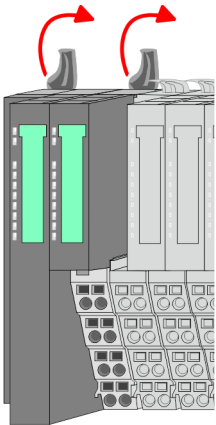

4. ➤

Turn all the locking lever of the bus coupler to be exchanged upwards.

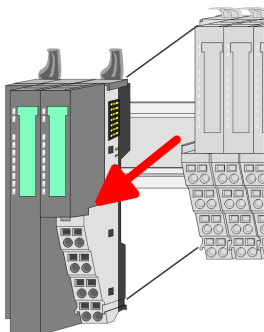

5. ➤

Pull the bus coupler forward.

6. ➤

For mounting turn all the locking lever of the bus coupler to be exchanged upwards.

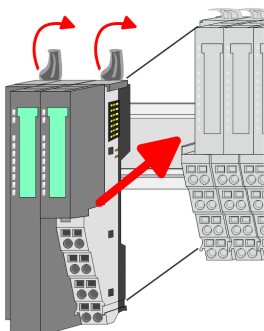

7. ➤

To mount the bus coupler put it to the left periphery module and push it, guided by the stripes, to the mounting rail.

8. ➤

Turn all the locking lever downward, again.

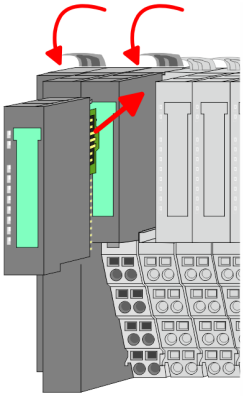

9. Plug again the electronic module, which you have removed before.
10. Wire your bus coupler.
 - ⇒ Now you can bring your system back into operation.

2.6.2 Demounting periphery modules

Proceeding

Exchange of an electronic module

1. Power-off your system.

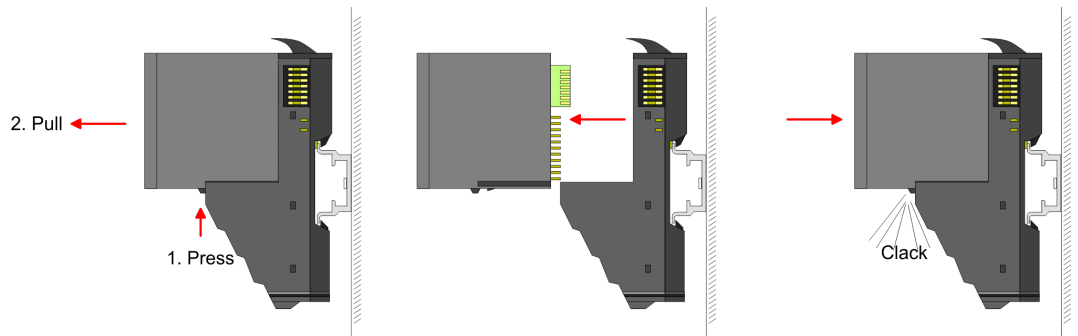

2. For the exchange of a electronic module, the electronic module may be pulled forward after pressing the unlocking lever at the lower side of the module.
3. For installation plug the new electronic module guided by the strips at the lower side until this engages to the terminal module.
 - ⇒ Now you can bring your system back into operation.

Exchange of a periphery module

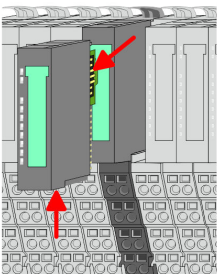

1. Power-off your system.
2. Remove if exists the wiring of the module.
- 3.

i For demounting and exchange of a (head) module or a group of modules, due to mounting reasons you always have to remove the electronic module right beside. After mounting it may be plugged again.

Press the unlocking lever at the lower side of the just mounted right module and pull it forward.

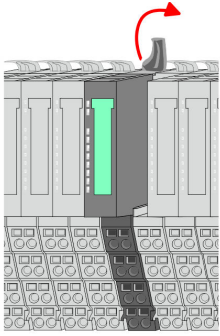

4. Turn the locking lever of the module to be exchanged upwards.

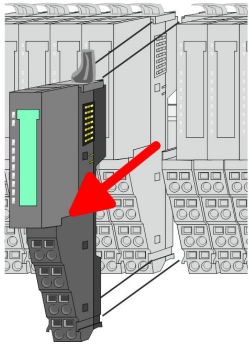

5. Pull the module.

6. For mounting turn the locking lever of the module to be mounted upwards.

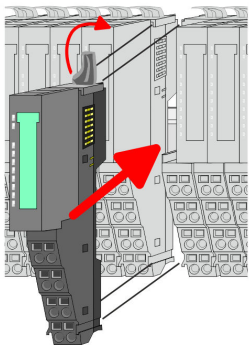

7. To mount the module put it to the gap between the both modules and push it, guided by the stripes at both sides, to the mounting rail.

8. Turn the locking lever downward, again.

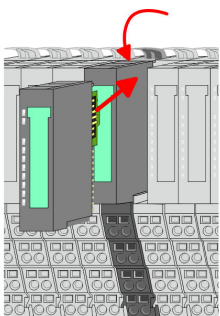

9. Plug again the electronic module, which you have removed before.

10. Wire your module.

⇒ Now you can bring your system back into operation.

Exchange of a module group

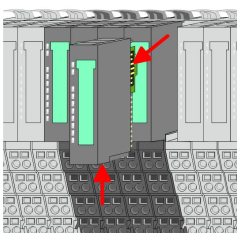

1. Power-off your system.

2. Remove if exists the wiring of the module group.

3.



For demounting and exchange of a (head) module or a group of modules, due to mounting reasons you always have to remove the electronic module right beside. After mounting it may be plugged again.

Press the unlocking lever at the lower side of the just mounted right module near the module group and pull it forward.

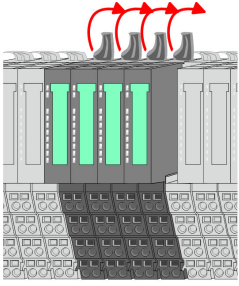

4. Turn all the locking lever of the module group to be exchanged upwards.

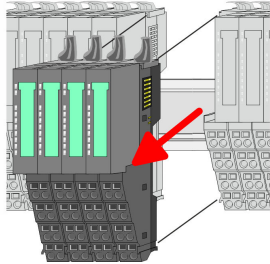

5. Pull the module group forward.

6. For mounting turn all the locking lever of the module group to be mounted upwards.

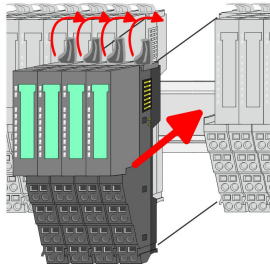

7. To mount the module group put it to the gap between the both modules and push it, guided by the stripes at both sides, to the mounting rail.

8. Turn all the locking lever downward, again.

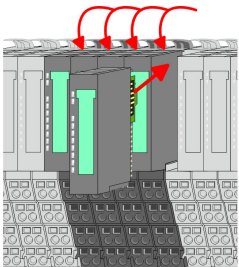

9. Plug again the electronic module, which you have removed before.

10. Wire your module group.

⇒ Now you can bring your system back into operation.

2.7 Trouble shooting - LEDs

General

Each module has the LEDs RUN and MF on its front side. Errors or incorrect modules may be located by means of these LEDs.

In the following illustrations flashing LEDs are marked by ☼.

Sum current of the electronic power supply exceeded

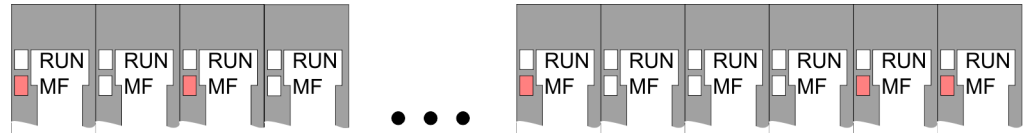

Behaviour: After PowerON the RUN LED of each module is off and the MF LED of each module is sporadically on.

Reason: The maximum current for the electronic power supply is exceeded.

Remedy: As soon as the sum current of the electronic power supply is exceeded, always place the power module 007-1AB10. ↪ Chap. 2.5.3 'Wiring power modules' page 22

Error in configuration

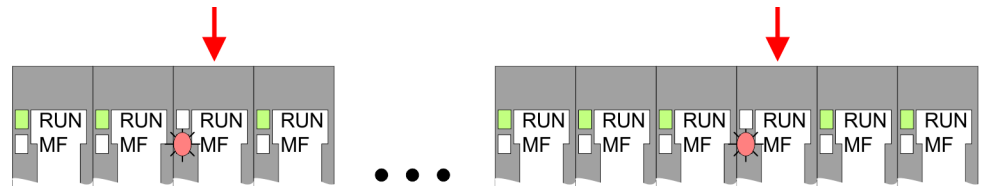

Behaviour: After PowerON the MF LED of one module respectively more modules flashes. The RUN LED remains off.

Reason: At this position a module is placed, which does not correspond to the configured module.

Remedy: Match configuration and hardware structure.

Module failure

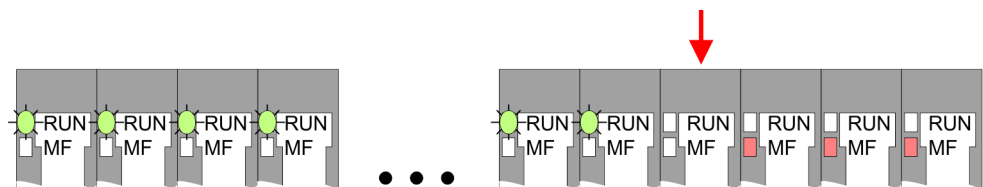

Behaviour: After PowerON all of the RUN LEDs up to the defective module are flashing. With all following modules the MF LED is on and the RUN LED is off.

Reason: The module on the right of the flashing modules is defective.

Remedy: Replace the defective module.

2.8 Installation guidelines

General	<p>The installation guidelines contain information about the interference free deployment of a PLC system. There is the description of the ways, interference may occur in your PLC, how you can make sure the electromagnetic compatibility (EMC), and how you manage the isolation.</p>
What does EMC mean?	<p>Electromagnetic compatibility (EMC) means the ability of an electrical device, to function error free in an electromagnetic environment without being interfered respectively without interfering the environment.</p> <p>The components of VIPA are developed for the deployment in industrial environments and meets high demands on the EMC. Nevertheless you should project an EMC planning before installing the components and take conceivable interference causes into account.</p>
Possible interference causes	<p>Electromagnetic interferences may interfere your control via different ways:</p> <ul style="list-style-type: none">■ Electromagnetic fields (RF coupling)■ Magnetic fields with power frequency■ Bus system■ Power supply■ Protected earth conductor <p>Depending on the spreading medium (lead bound or lead free) and the distance to the interference cause, interferences to your control occur by means of different coupling mechanisms.</p> <p>There are:</p> <ul style="list-style-type: none">■ galvanic coupling■ capacitive coupling■ inductive coupling■ radiant coupling
Basic rules for EMC	<p>In the most times it is enough to take care of some elementary rules to guarantee the EMC. Please regard the following basic rules when installing your PLC.</p> <ul style="list-style-type: none">■ Take care of a correct area-wide grounding of the inactive metal parts when installing your components.<ul style="list-style-type: none">– Install a central connection between the ground and the protected earth conductor system.– Connect all inactive metal extensive and impedance-low.– Please try not to use aluminium parts. Aluminium is easily oxidizing and is therefore less suitable for grounding.■ When cabling, take care of the correct line routing.<ul style="list-style-type: none">– Organize your cabling in line groups (high voltage, current supply, signal and data lines).– Always lay your high voltage lines and signal respectively data lines in separate channels or bundles.– Route the signal and data lines as near as possible beside ground areas (e.g. suspension bars, metal rails, tin cabinet).

- Proof the correct fixing of the lead isolation.
 - Data lines must be laid isolated.
 - Analog lines must be laid isolated. When transmitting signals with small amplitudes the one sided laying of the isolation may be favourable.
 - Lay the line isolation extensively on an isolation/protected earth conductor rail directly after the cabinet entry and fix the isolation with cable clamps.
 - Make sure that the isolation/protected earth conductor rail is connected impedance-low with the cabinet.
 - Use metallic or metallised plug cases for isolated data lines.
- In special use cases you should appoint special EMC actions.
 - Consider to wire all inductivities with erase links.
 - Please consider luminescent lamps can influence signal lines.
- Create a homogeneous reference potential and ground all electrical operating supplies when possible.
 - Please take care for the targeted employment of the grounding actions. The grounding of the PLC serves for protection and functionality activity.
 - Connect installation parts and cabinets with your PLC in star topology with the isolation/protected earth conductor system. So you avoid ground loops.
 - If there are potential differences between installation parts and cabinets, lay sufficiently dimensioned potential compensation lines.

Isolation of conductors

Electrical, magnetically and electromagnetic interference fields are weakened by means of an isolation, one talks of absorption. Via the isolation rail, that is connected conductive with the rack, interference currents are shunt via cable isolation to the ground. Here you have to make sure, that the connection to the protected earth conductor is impedance-low, because otherwise the interference currents may appear as interference cause.

When isolating cables you have to regard the following:

- If possible, use only cables with isolation tangle.
- The hiding power of the isolation should be higher than 80%.
- Normally you should always lay the isolation of cables on both sides. Only by means of the both-sided connection of the isolation you achieve high quality interference suppression in the higher frequency area. Only as exception you may also lay the isolation one-sided. Then you only achieve the absorption of the lower frequencies. A one-sided isolation connection may be convenient, if:
 - the conduction of a potential compensating line is not possible.
 - analog signals (some mV respectively μA) are transferred.
 - foil isolations (static isolations) are used.
- With data lines always use metallic or metallised plugs for serial couplings. Fix the isolation of the data line at the plug rack. Do not lay the isolation on the PIN 1 of the plug bar!
- At stationary operation it is convenient to strip the insulated cable interruption free and lay it on the isolation/protected earth conductor line.
- To fix the isolation tangles use cable clamps out of metal. The clamps must clasp the isolation extensively and have well contact.
- Lay the isolation on an isolation rail directly after the entry of the cable in the cabinet. Lead the isolation further on to your PLC and don't lay it on there again!



CAUTION!

Please regard at installation!

At potential differences between the grounding points, there may be a compensation current via the isolation connected at both sides.

Remedy: Potential compensation line

General data

2.9 General data

Conformity and approval		
Conformity		
CE	2014/35/EU	Low-voltage directive
	2014/30/EU	EMC directive
Approval		
UL	-	Refer to Technical data
others		
RoHS	2011/65/EU	Restriction of the use of certain hazardous substances in electrical and electronic equipment

Protection of persons and device protection		
Type of protection	-	IP20
Electrical isolation		
to the field bus	-	electrically isolated
to the process level	-	electrically isolated
Insulation resistance	-	-
Insulation voltage to reference earth		
Inputs / outputs	-	AC / DC 50V, test voltage AC 500V
Protective measures	-	against short circuit

Environmental conditions to EN 61131-2		
Climatic		
Storage / transport	EN 60068-2-14	-25...+70°C
Operation		
Horizontal installation hanging	EN 61131-2	0...+60°C
Horizontal installation lying	EN 61131-2	0...+55°C
Vertical installation	EN 61131-2	0...+50°C
Air humidity	EN 60068-2-30	RH1 (without condensation, rel. humidity 10...95%)
Pollution	EN 61131-2	Degree of pollution 2
Installation altitude max.	-	2000m
Mechanical		
Oscillation	EN 60068-2-6	1g, 9Hz ... 150Hz
Shock	EN 60068-2-27	15g, 11ms

Mounting conditions

Mounting place	-	In the control cabinet
Mounting position	-	Horizontal and vertical

EMC	Standard	Comment
Emitted interference	EN 61000-6-4	Class A (Industrial area)
Noise immunity zone B	EN 61000-6-2	Industrial area
	EN 61000-4-2	ESD 8kV at air discharge (degree of severity 3), 4kV at contact discharge (degree of severity 2)
	EN 61000-4-3	HF field immunity (casing) 80MHz ... 1000MHz, 10V/m, 80% AM (1kHz) 1.4GHz ... 2.0GHz, 3V/m, 80% AM (1kHz) 2GHz ... 2.7GHz, 1V/m, 80% AM (1kHz)
	EN 61000-4-6	HF conducted 150kHz ... 80MHz, 10V, 80% AM (1kHz)
	EN 61000-4-4	Burst, degree of severity 3
	EN 61000-4-5	Surge, degree of severity 3 *

*) Due to the high-energetic single pulses with Surge an appropriate external protective circuit with lightning protection elements like conductors for lightning and overvoltage is necessary.

3 Hardware description

3.1 Properties

053-1ML00

- Field bus: MECHATROLINK-III according to IEC 61158, IEC 61784
- MECHATROLINK-III coupler for max. 64 periphery modules
- Supports standard I/O profile (16byte and 64byte mode)
- Multi slave node with max. 9 stations
 - 1 coupler (address extension 00h)
 - Periphery module (from address 01h)
- Max. 492byte input and 492byte output data
 - Coupler: 12byte input and 12byte output data
 - Periphery module: 480byte input and 480byte output data
- Integrated DC 24V power supply for power and electronic section supply of the periphery modules
- Integrated web server
- Configuration is done via software tool respectively web server

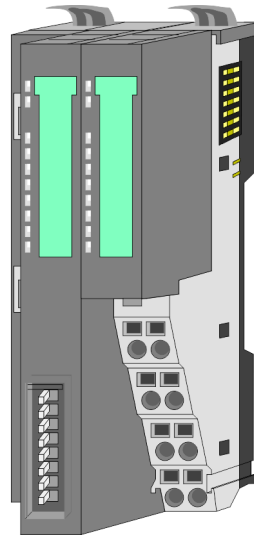

Ordering data

Type	Order number	Description
IM 053ML	053-1ML00	MECHATROLINK-III coupler for System SLIO

3.2 Structure

053-1ML00

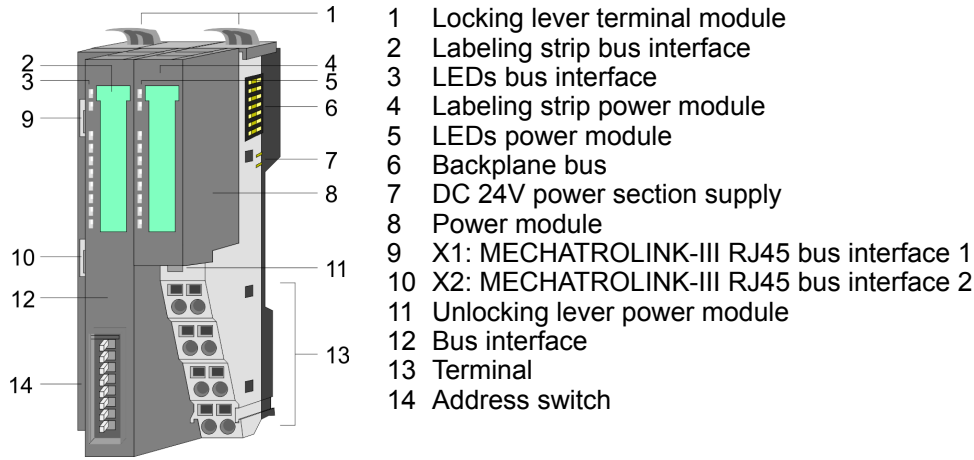

3.2.1 Interfaces

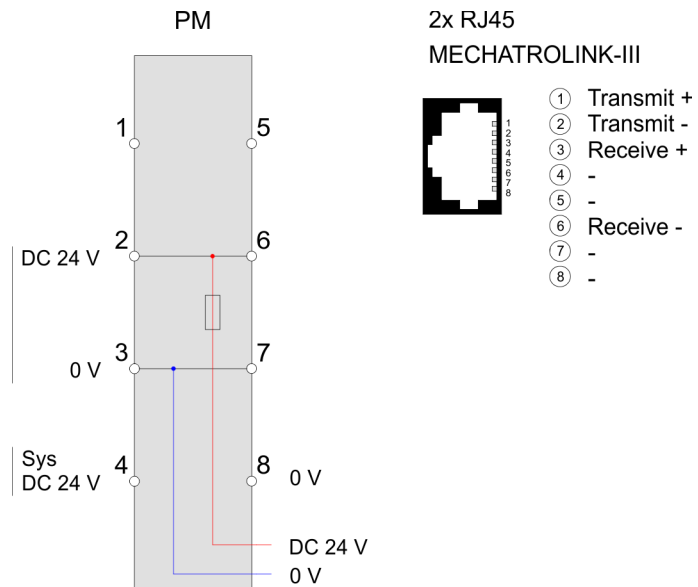

CAUTION!

Bus interface and power module of the bus coupler may not be separated!

Here you may only exchange the electronic module!

PM - Power module

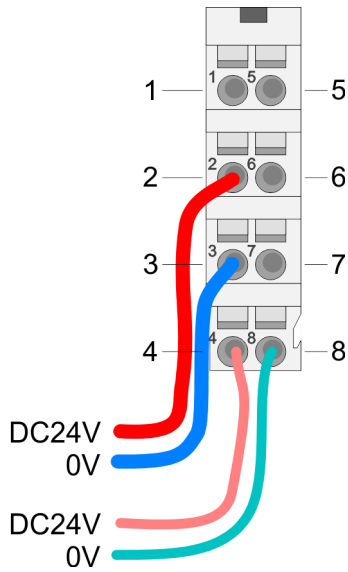

For wires with a core cross-section of 0.08mm² up to 1.5mm².

Pos.	Function	Type	Description
1	---	---	not connected
2	DC 24V	I	DC 24V for power section supply
3	0V	I	GND for power section supply
4	Sys DC 24V	I	DC 24V for electronic section supply
5	---	---	not connected
6	DC 24V	I	DC 24V for power section supply
7	0V	I	GND for power section supply
8	Sys 0V	I	GND for electronic section supply

I: Input

X1/X2: MECHATROLINK-III interface

RJ45 jacks

- MECHATROLINK-III connection via 2 RJ45 jacks (2 ports) by means of a MECHATROLINK cable
- MECHATROLINK-III master (C1 or C2) in the network required for operation
- Cascade and star topology are possible

3.2.2 LEDs

LEDs power module

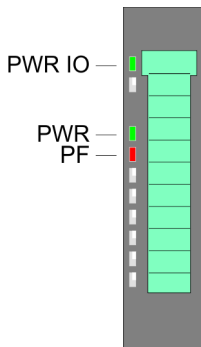





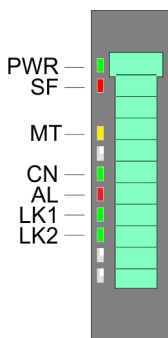

































PWR IO	PWR	PF	Description
■ green	■ green	■ red	
■	X	□	Power section supply OK
■	■	□	Electronic section supply OK
X	X	■	Fuse electronic section supply defective
not relevant: X			

LEDs bus interface



LED	Color	Description
PWR	■ green	Bus interface is power supplied
SF	■ red	System error: Error on System SLIO bus
MT	■ yellow	MECHATROLINK-III mode status (maintenance mode)
CN	■ green	MECHATROLINK-III connection status
AL	■ red	MECHATROLINK-III error status
LK1	■ green	Link port 1: Physical connection to MECHATROLINK-III
LK2	■ green	Link port 2: Physical connection to MECHATROLINK-III

PWR  green	SF  red	MT  yellow	CN  green	AL  red	LK1  green	LK2  green	Description
	X	X	X	X	X	X	The MECHATROLINK-III coupler is power supplied.
		X	X	X	[]	[]	No connection can be established to the MECHATROLINK-III master, but there is a physical connection. LK1 or LK2 is on.
		X					There is no physical connection to Ethernet. LK1 and LK2 is off.
		X	X	X	X	X	<ul style="list-style-type: none"> An unacknowledged diagnostic message is pending. Error on the backplane bus (e.g. module failure, bus faulted). Error during firmware update (shortly visible, then restart).
	 1Hz		X	X	X	X	<ul style="list-style-type: none"> Error in the configuration At least one module does not match the configuration The outputs of all output modules are disabled
	 2Hz		X	X	X	X	<ul style="list-style-type: none"> There is a module with an FPGA version lower than V 228 There is a module which is not supported The outputs of all output modules are disabled
	 1Hz	 1Hz	X	X	X	X	A firmware update is in progress.
			X	X	X	X	MECHATROLINK-III coupler is in <i>maintenance mode</i> and can be configured
			X	X	X	X	MECHATROLINK-III coupler is in <i>standard mode</i>
	X	X	X	 1Hz	X	X	MECHATROLINK-III communication error An error occurred during communication via MECHATROLINK-III
	X	X	X	 2Hz	X	X	MECHATROLINK-III address error The address set on the MECHATROLINK-III coupler is incorrect or invalid
	X	X	X	X		X	Port 1 is physically linked to MECHATROLINK-III
	X	X	X	X	X		Port 2 is physically linked to MECHATROLINK-III

Option: [] not relevant: X

3.2.3 Address switch

Address switch



An address may only be assigned once in the MECHATROLINK-III network! Changes of the address switch were only recognized after PowerON or a Reset!

The address set on the address switch must always be identical to the device address in your configuration tool!

The address switch serves for the following settings:

- Selection of the operating mode
- Adaptation of the MECHATROLINK-III address

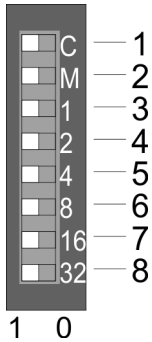

Position	Designation	Description
1	C	Operating mode <ul style="list-style-type: none"> ■ 0: <i>Standard mode</i> (default) <ul style="list-style-type: none"> – Default setting – I/O data transfer and configuration are possible via MECHATROLINK-III – MECHATROLINK-III address selectable via DIP switch (0x03 ... 0x3F) ■ 1: <i>Maintenance mode</i> <ul style="list-style-type: none"> – In this mode, the module can be configured. – Configuration is only possible via the integrated web page or via the configuration tool – Octet of the MECHATROLINK-III address 192.168.1.x selectable via DIP switch (x: 1 ... 63) Please change the operating mode only when powered off!
2	M	Reserved - leave the switch position at 0.
3	$2^0 = 1$	MECHATROLINK-III address: <ul style="list-style-type: none"> ■ Standard mode <ul style="list-style-type: none"> – Address range 0x03 ... 0x3F – Hexadecimal value from position 3 ... 8 – Is the address in the range 0x00 ... 0x02, the address 0x03 is used ■ Maintenance mode <ul style="list-style-type: none"> – Octet of the IP address 192.168.1.x with x: 1 ... 63 – x = decimal value from position 3 ... 8 – If the address 192.168.1.0 is set, the address 192.168.1.1 is used.
4	$2^1 = 2$	
5	$2^2 = 4$	
6	$2^3 = 8$	
7	$2^4 = 16$	
8	$2^5 = 32$	

0 = disabled, 1 = enabled

3.3 Technical data

Order no.	053-1ML00
Type	IM 053ML - MECHATROLINK
Module ID	-
Technical data power supply	
Power supply (rated value)	DC 24 V
Power supply (permitted range)	DC 20.4...28.8 V
Reverse polarity protection	✓
Current consumption (no-load operation)	95 mA
Current consumption (rated value)	0.95 A
Inrush current	3.9 A
I^2t	0.14 A ² s
Max. current drain at backplane bus	3 A
Max. current drain load supply	10 A
Power loss	3 W
Status information, alarms, diagnostics	
Status display	yes
Interrupts	yes, parameterizable
Process alarm	yes, parameterizable
Diagnostic interrupt	yes, parameterizable
Diagnostic functions	yes, parameterizable
Diagnostics information read-out	possible
Supply voltage display	green LED
Service Indicator	yellow LED
Group error display	red SF LED
Channel error display	none
Hardware configuration	
Racks, max.	1
Modules per rack, max.	64
Number of digital modules, max.	64
Number of analog modules, max.	64
Communication	
Fieldbus	MECHATROLINK-III
Type of interface	Ethernet 100 MBit
Connector	2 x RJ45
Topology	-
Electrically isolated	✓

Technical data

Order no.	053-1ML00
Number of participants, max.	-
Node addresses	-
Transmission speed, min.	100 Mbit/s
Transmission speed, max.	100 Mbit/s
Address range inputs, max.	492 Byte
Address range outputs, max.	492 Byte
Number of TxPDOs, max.	-
Number of RxPDOs, max.	-
Functionality MECHATROLINK-III slave	
Supported profile	Standard I/O profiles
Supported transfer cycle	125us, 250us, 500us, 750us, 1ms.... 8ms (every 500us)
Cyclic data size per node	16byte (slave), 64byte (peripheral)
Max. Number of nodes	9 (00h : for slave, 01h-08h for modules)
Supported communication method	Cyclic, Event driven, Message
Supported command "Cyclic"	NOP, ID_RD, CONFIG, ALM_RD, ALM_CLR, SYNC_SET, CONNECT, DISCONNECT, DATA_RWA, DATA_RWS
Supported command "Event driven"	NOP, ID_RD, CONNECT, DISCONNECT
Supported command "Message"	Memory read , Read max message size, Download request, Download data, Download complete
Datasizes	
Input bytes	492
Output bytes	492
Parameter bytes	-
Diagnostic bytes	-
Housing	
Material	PPE / PPE GF10
Mounting	Profile rail 35 mm
Mechanical data	
Dimensions (WxHxD)	48.5 mm x 109 mm x 76.5 mm
Net weight	167.5 g
Weight including accessories	167.5 g
Gross weight	185 g
Environmental conditions	
Operating temperature	0 °C to 60 °C
Storage temperature	-25 °C to 70 °C
Certifications	

Order no.	053-1ML00
UL certification	in preparation
KC certification	in preparation

4 Deployment

4.1 Basics MECHATROLINK-III

Transfer medium

MECHATROLINK-III is compatible to Ethernet in accordance with the IEEE standards. Connection can be either point-to-point or in *cascade* or *star* topology. For use in star topology, always use a *hub module*. The specification of MECHATROLINK-III is listed below.

Parameter	Properties
Transfer cable	CAT5e STP (shielded twisted-pair cable) - crossover Ethernet cable
Connection	RJ45 or industrial miniature I/O connector
Max. network expansion	6300m
Max. distance between 2 stations	100m
Number of connected stations	C1 master station: 1, C2 master station: max. 62 For a cascade topology max. 19 stations can be connected.
Transfer rate	100Mbps
Channel coding	4B/5B MLT-3
Station types	C1 master: Network management station C2 master: Message master station Slave/multi-slave: Passive station
Access control	Master - slave
Number of bytes in the information field	8/16/32/48/64 bytes (can be mixed)
Electrical isolation between device and network	Isolation transformer



- *It is a crossover Ethernet cable to be used.*
- *For a cascaded connection, the number of couplers to be synchronized must be 19 or less.*

4.2 MECHATROLINK-III installation guidelines

Generals to data security

- The topic of data security and access protection have become increasingly important in the industrial environment. The increased networking of entire industrial systems to the network levels within the company together with the functions of remote maintenance have all served to increase vulnerability.
- Threats can arise from internal manipulation like technical errors, operator and program errors respectively from external manipulation like software viruses and worms, trojans and password phishing.

Precautions

The most important precautions to prevent manipulation and loss of data security in the industrial environment are:

- Encrypting the data traffic by means of certificates.
- Filtering and inspection of the traffic by means of VPN - "Virtual Private Networks".
- Identification of the nodes by "Authentication" via save channels.
- Segmenting in protected automation cells, so that only devices in the same group can exchange data.

Guidelines for information security

- With the "VDI/VDE 2182 sheet 1", Information Security in the Industrial Automation - General procedural model, VDI guidelines, the VDI/VDE society for measuring and automation engineering has published a guide for implementing a security architecture in the industrial environment. The guideline can be found at www.vdi.de

Industrial Ethernet

- Due to the open standard of MECHATROLINK-III standard Ethernet components may be used. For industrial environment and due to the high transfer rate of 100MBit/s your MECHATROLINK-III system should consist of Industrial Ethernet components.
- All the devices interconnected to MECHATROLINK-III are located in one and the same network. All the devices in a network can communicate directly with each other.
- A network is physically limited by a router. If devices need to communicate beyond the limits of a network, you have to configure the router so that it allows this communication to take place.

4.2.1 Topology

Cascade

- With the cascade structure all the communication devices are connected via a linear bus topology. Here, the line structure is realized via the RJ45 jacks (port 1/2), which are already integrated in the MECHATROLINK-III devices.
- If a communication member fails, the communication across the failed member is not possible.

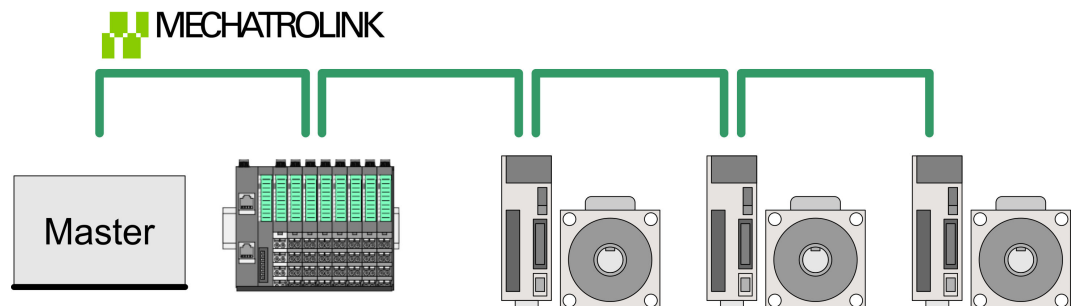

Star

- If you connect communication devices to a *Hub module* like YASKAWA JEPMC-MT2000-E with more than 2 MECHATROLINK-III interfaces, you automatically create a star network topology.
- If an individual MECHATROLINK-III device fails, this does not automatically lead to failure of the entire network, in contrast to other structures. Here, only the subnetwork that contains the faulty MECHATROLINK-III device fails.

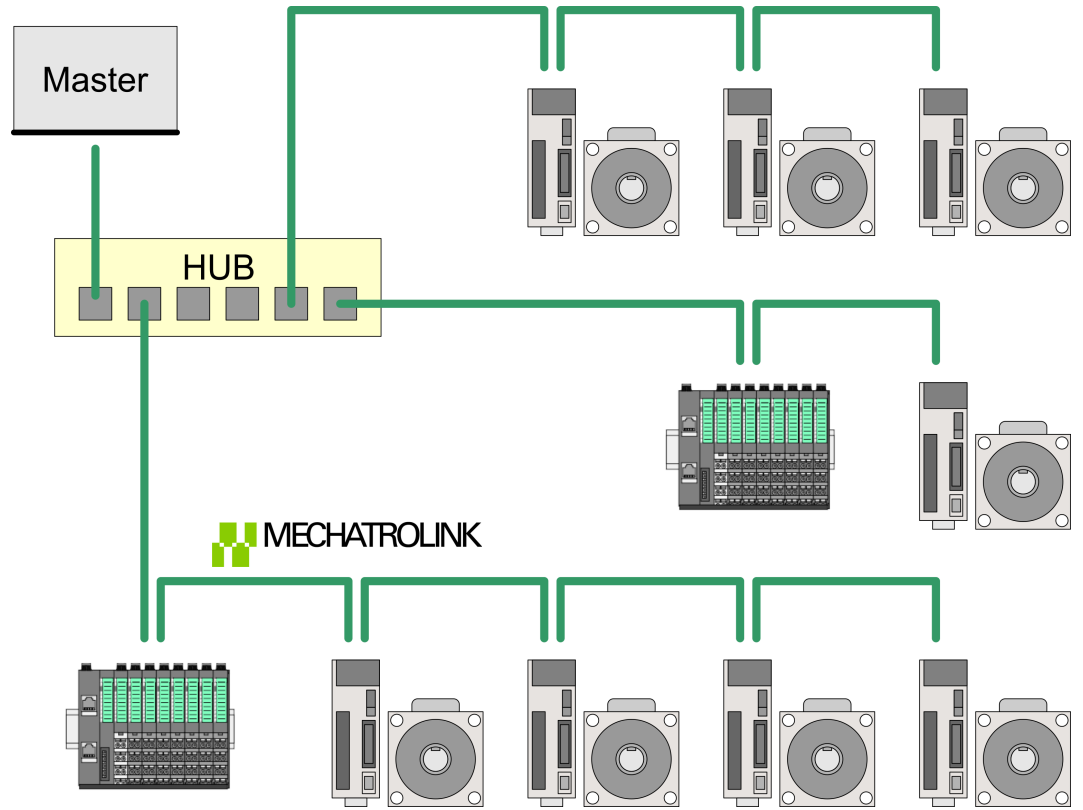

4.3 Accessing the System SLIO

4.3.1 Supported modules

Hardware revision

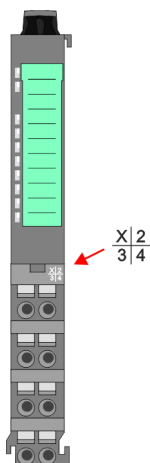

Please note that modules are only supported which are starting from the specified hardware revision. This corresponds to the FPGA version V228 or higher of the module. If there is a module with an older hardware revision or there is a not supported module, the outputs are disabled and the SF LED starts blinking.

- Information on the hardware revision can be found on the front side of the terminal module. The hardware revision (here 1) is labelled with an X.
- You can also use the web server to determine the hardware revision. [Chap. 4.6 'Web server' page 54](#)

Order no.	Description	HW rev.
Digital input modules		
021-1BB00	2 inputs	2
021-1BB10	2 fast inputs, input filter, time delay parametrizable	2
021-1BD00	4 inputs	2
021-1BD10	4 fast inputs, input filter, time delay parametrizable	2
021-1BD40	4 inputs, connect 2/3-wire	2
021-1BD50	4 inputs, NPN	2
021-1BF00	8 inputs	2
021-1BF01	8 inputs, 0.5ms	1
021-1BF50	8 inputs, NPN	2
021-1DF00	8 inputs, diagnosis	1
Digital output modules		
HW rev.		
022-1BB00	2 outputs, output current 0.5A	2
022-1BB90	2 outputs, PWM	2
022-1BD00	4 outputs, output current 0.5A	2
022-1BD20	4 outputs, output current 2A	2
022-1BD50	4 outputs, NPN, output current 0.5A	2
022-1BF00	8 outputs, output current 0.5A	2
022-1BF50	8 outputs, NPN, output current 0.5A	2
022-1HB10	2 relay outputs, DC 30V / AC 230V, output current 3A	4
022-1HD10	4 relay outputs, DC 30V / AC 230V, output current 1.8A	4
022-1DF00	8 outputs, output current 0.5A, diagnosis	1

Analog input modules		HW rev.
031-1BB10	2 inputs 12bit, current 0(4) ... 20mA, 2 wire	2
031-1BB30	2 inputs 12bit, voltage 0 ... 10V	2
031-1BB40	2 inputs 12bit, current 0(4) ... 20mA	2
031-1BB60	2 inputs 12bit, current 0(4) ... 20mA, 2 wire	1
031-1BB70	2 inputs 12bit, voltage -10 ... +10V	2
031-1BB90	2 inputs 16bit Thermocouple, voltage -80mV ... +80mV	4
031-1BD30	4 inputs 12bit, voltage 0 ... 10V	2
031-1BD40	4 inputs 12bit, current 0(4) ... 20mA	2
031-1BD70	4 inputs 12bit, voltage -10 ... +10V	2
031-1CB30	2 inputs 16bit, voltage 0 ... 10V	2
031-1CB40	2 inputs 16bit, current 0(4) ... 20mA	2
031-1CB70	2 inputs 16bit, voltage -10 ... +10V	2
031-1CD30	4 inputs 16bit, voltage 0 ... 10V	2
031-1CD35	4 inputs 16bit, voltage 0 ... 10V	1
031-1CD40	4 inputs 16bit, current 0(4) ... 20mA	2
031-1CD45	4 inputs 16bit, current 0(4) ... 20mA	1
031-1CD70	4 inputs 16bit, voltage -10 ... +10V	2
031-1LB90	2 inputs 16bit, Thermocouple, voltage -80mV ... +80mV (less parameters)	2
031-1PA00	Energy measurement terminal 1/3 phase 230 / 400V, 1A	1
031-1PA10	Energy measurement terminal 1/3 phase 230 / 400V, 5A	2

Analog output modules		HW rev.
032-1BB30	2 outputs 12bit, voltage 0 ... 10V	2
032-1BB40	2 outputs 12bit, current 0(4) ... 20mA	2
032-1BB70	2 outputs 12bit, voltage -10 ... +10V	2
032-1BD30	4 outputs 12bit, voltage 0 ... 10V	2
032-1BD40	4 outputs 12bit, current 0(4) ... 20mA	2
032-1BD70	4 outputs 12bit, voltage -10 ... +10V	2
032-1CB30	2 outputs 16bit, voltage 0 ... 10V	2
032-1CB40	2 outputs 16bit, current 0(4) ... 20mA	1
032-1CB70	2 outputs 16bit, voltage -10 ... +10V	2
032-1CD30	4 outputs 16bit, voltage 0 ... 10V	2
032-1CD40	4 outputs 16bit, current 0(4) ... 20mA	2
032-1CD70	4 outputs 16bit, voltage -10 ... +10V	2

Counter modules		HW rev.
050-1BA00	1 Counter 32bit (AB), DC 24V	2
050-1BA10	1 Counter 32bit (AB), DC 5V (difference signal)	2
050-1BB00	2 Counter 32bit (AB), DC 24V	2

Counter modules		HW rev.
050-1BB30	2 Counter 32bit (AB), DC 24V	2
050-1BB40	Frequency measurement, 2 channels 24Bit, DC 24V	2
Power supply modules		HW rev.
007-1AB00	Power supply DC 24V, 10A	1
007-1AB10	Power supply DC 24V, 4A, backplane bus 5V, 2A	1
Distribution modules		HW rev.
001-1BA00	8 * DC 24V	1
001-1BA10	8 * DC 0V	1
001-1BA20	4 * DC 24V, 4 * DC 0V	1
Line extension modules		HW rev.
060-1AA00	IM 060 Line extension (master)	1
061-1BA00	IM 061 Line extension (slave)	1

4.3.2 Overview

After switching on, the coupler automatically detects the modules on the backplane bus and assigns their I/O areas to I/O groups. The assignment happens with the following proceeding:

- The coupler IM 053ML uses the address extension 00h
- The coupler IM 053ML automatically determines the peripheral modules and combines their I/O areas to 60byte groups.
- Each I/O group is assigned to an address extension starting from 01h to max. 08h.
- The offset is always 2bytes.
- If the maximum size of 60bytes is exceeded when assigning an input or output area of a peripheral module, the corresponding I/O area is assigned to the next I/O group. This group gets the next higher address extension.



- Information concerning the allocation of these areas may be found in the description of the corresponding System SLIO module.
- Please consider the System SLIO power and clamp modules do not have any module ID. These may not be recognized by the MECHATROLINK-III coupler and so are not listed respectively considered during slot allocation.

4.3.3 Example

System

In the following an example of accessing to the System SLIO is shown.

Slot:	0	1	2	3	4	5	6	7
	IM 053ML	SM 021 DI 4x	SM 021 DI 4x	FM 050 Counter	FM 050 Counter	FM 050 Counter	FM 050 Counter	FM 050 Counter
OUT:	Bytes: 12	Bytes: 1	Bytes: 1	Bytes: 12	Bytes: 12	Bytes: 12	Bytes: 12	Bytes: 12
IN:	Bytes: 12			Bytes: 4	Bytes: 4	Bytes: 4	Bytes: 4	Bytes: 4

Coupler 053-1ML00

The coupler 053-1ML00 uses 12bytes each and uses the address extension 00h



Periphery modules

The coupler 053-1ML00 automatically determines the peripheral modules and combines their I/O areas to 60byte groups.

The 1. I/O group gets the address extension 01h

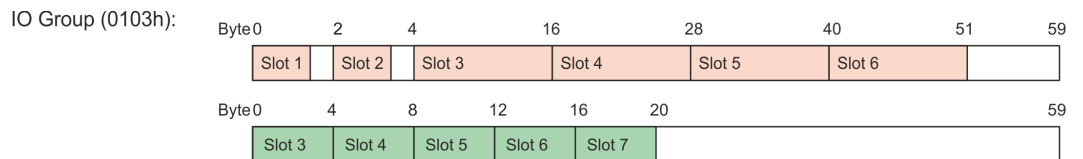

The 2. I/O group is required because the 12bytes no longer fit into group 1 for input.

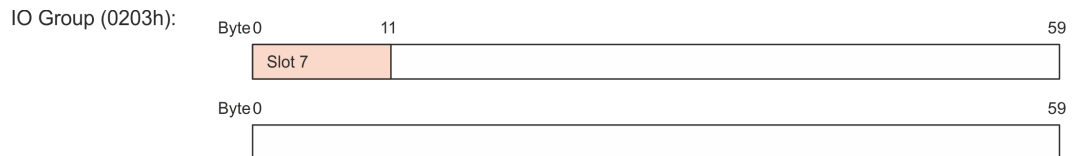

4.4 Communication with the MECHATROLINK-III master

- In the MECHATROLINK-III master the coupler IM 053ML is handled as a multi-slave coupler.
- The master has the address 01h.
- The I/O areas of the periphery modules are accessed via the coupler address (here address 03) and the address extension of the corresponding I/O group.

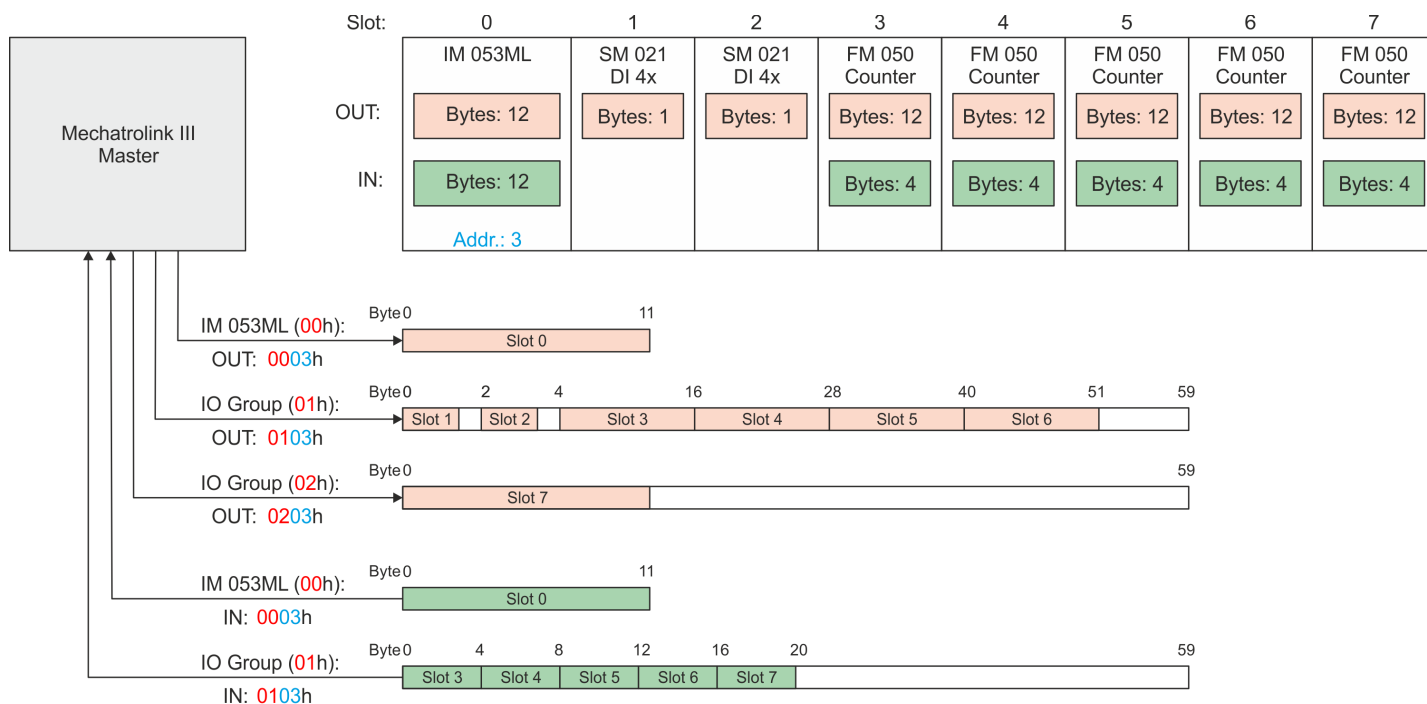

4.5 I/O area of the IM 053ML

Structure

The bus coupler uses 12bytes for input data and 12bytes for output data. In cyclic communication you can access the I/O area via *DATA_RWA* (20h) respectively *DATA_RWS* (21h). The I/O area has the following structure:

Byte	Output data	Input data
0 ... 1	Reserved	Status
2	<i>Coupler command</i>	<i>Command response</i>
3	<i>Command ID</i>	<i>Response ID</i>
4 ... 11	<i>Command data</i>	<i>Response data</i>

Status

Byte	Description
0	<ul style="list-style-type: none"> ■ Bit 0: An error occurred while processing <i>Coupler command</i>. ■ Bit 1: <i>Coupler command</i> is currently being processed.
1	Reserved

Coupler command and *Command response*

For sending a command via *Coupler command*, you receive the command code via *Command response* as confirmation.

Code	Name	Description
0x00	Read interrupt counter	Read the hardware / diagnostic interrupt counter
0x01	Read hardware interrupt slot	Read the hardware interrupt data of a module
0x02	Read diagnostic interrupt slot	Read the diagnostic interrupt data of a module
0x03	Reset interrupt data	Delete the interrupt data of a module
0x04	Read memory	Read the virtual memory
0x05	Write parameter	Write module parameter

Command ID and *Response ID*

ID of the coupler command for identification, if you want to use the command multiple times.

Command data and *Response data*

Use and structure of the data areas depends on the command used.

Read interrupt counter (0x00)

Byte	Command data	Response data
4 ... 7	-	Counter hardware interrupt
8 ... 11	-	Counter diagnostic interrupt

Read hardware interrupt slot (0x01)

Byte	Command data	Response data
4 ... 11	-	Hardware interrupt status <ul style="list-style-type: none"> ■ Bit 0: Slot 1 ■ Bit 1: Slot 2 ■ ... ■ Bit 63: Slot 64

Read diagnostic interrupt slot (0x02)

Byte	Command data	Response data
4 ... 11	-	Diagnostic interrupt status <ul style="list-style-type: none"> ■ Bit 0: Slot 1 ■ Bit 1: Slot 2 ■ ... ■ Bit 63: Slot 64

Reset diagnostic data (0x03)

Byte	Command data	Response data
4 ... 5	Slot number (1 ... 64)	Slot number as response
6 ... 11	-	0 (fix)

Read memory (0x04)

Byte	Command data	Response data
4	Byte size (0 ... 8)	Depends on the virtual memory
5		
6 ... 7	Reserved	
8 ... 11	Offset	

Write parameter (0x05)

Byte	Command data	Response data
4	Parameter ID as value of SX from the manual of the module.	<ul style="list-style-type: none"> ■ 0: no error ■ 1: Module or parameter does not exist ■ 2: Faulty parameter size ■ 3: Parameter can not be overwritten at runtime
5	Slot number (1 ... 64)	
6 ... 7	Size of parameter data in bytes (1 ... 4)	
8 ... 11	Parameter data	

4.6 Web server

Access via IP address

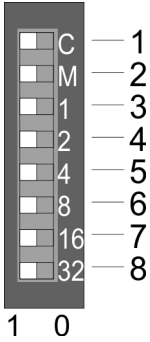

On delivery, the web server is deactivated. The activation happens with the following proceeding:

1. ➤ Switch off the power supply of the *MECHATROLINK-III* coupler.
2. ➤ Set at the address switch the *operating mode 'C'* (position 1) 1: *Maintenance mode*.
3. ➤ At the address switch, set the *MECHATROLINK-III* address as the IP address.
 ↳ *Chap. 3.2.3 'Address switch' page 40*
4. ➤ Switch on the power supply of the *MECHATROLINK-III* coupler.
 - ⇒ The coupler is now in maintenance mode. The integrated web server may be accessed via the following IP address:
 - Subnet mask: 255.255.255.0
 - IP address: 192.168.1.x
 with x = decimal value of position 2...8 of the address switch

Structure of the web page

The web page is built dynamically and depends on the number of modules, which are connected to the *MECHATROLINK-III* coupler.



Please consider the System SLIO power and clamp modules do not have any module ID. These may not be recognized by the MECHATROLINK-III coupler and so are not listed respectively considered during slot allocation.

The screenshot shows a web interface with a module list on the left and a configuration panel on the right. Red arrows point to specific elements: [1] points to the module list, [2] points to the 'Info' tab, and [3] points to the 'Device (... 053-1ML00) information' table.

Name	Value
Ordering Info	053-1ML00
Serial	00101272
Version	01V10.001
HW Revision	01
Software	01

- [1] Module list: *MECHATROLINK-III* coupler and System SLIO modules in plugged order
- [2] Functions for the module, which is selected in the *module list*
- [3] Information respectively input field for the according function



For fast diagnostic missing or incorrectly configured modules are shown after updating the web page in the module list in red. The modules in blue are modules with or without configuration.

Web page with selected *MECHATROLINK-III* coupler



The screenshot shows a web interface with a sidebar on the left and a main content area on the right. The sidebar contains a list of devices:

- Device (... 053-1ML00) ← (indicated by a red arrow)
- [A] Module 1 (... 021-1BD00)
- [A] Module 2 (... 022-1BD00)

 The main content area has a tabbed interface with tabs for Info, Data, Parameter, Diagnosis, Security, IP, Firmware, and Configuration. The 'Info' tab is active, displaying 'Device (... 053-1ML00) information' in a table:

Name	Value
Ordering Info	053-1ML00
Serial	00101272
Version	01V10.001
HW Revision	01
Software	01

Info Here order number, serial number and the version of firmware and hardware of the *MECHATROLINK-III* coupler are listed.

Data The size of the process output and the process input image and the offset are shown here.

Parameter This functionality is currently not supported.

Diagnosis In this register diagnostic messages are shown. Please note that some diagnostic messages may be triggered due to an outdated firmware version. The following diagnostic messages are supported:

Code	Description
E000 00YYh	Error at access to the module at slot YY. Please retry after reboot.
E010 00YYh	Error accessing the retentive memory of the module at slot YY. Please try again after a restart respectively delete the parameters in the retentive memory and restart or carry out a firmware update.
A000 00YYh	The module version on slot YY is not supported.
A010 00YYh	
A020 00YYh	The assembled module in slot YY does not match the configured module in the retentive memory.
A030 00YYh	The module in slot YY has been configured and stored in retentive memory but not mounted.
A040 00YYh	Error writing parameter of the module at slot YY. Check your module parameters.

Security This functionality is currently not supported.

IP Here you get the current IP address of the *MECHATROLINK-III* coupler.

Web server

Firmware

With this function you can bring in a firmware update. You can get the appropriate firmware file from VIPA. During the firmware update, SF and MT are blinking alternately. When the update is finished, all the red LEDs are switched ON! After this perform a power cycle.

Configuration

In this dialog box, you have the option to save the current module configuration of your *MECHATROLINK-III* coupler externally or to load a saved one. Before saving the module configuration you should delete an existing one.

Web page with selected module

The screenshot shows a web interface with a list of modules on the left and a detailed information table for the selected module on the right. A red arrow points from the selected module in the list to the information table.

Module 1 (... 021-1BD00) information

Name	Value
Ordering Info	021-1BD00
Serial	00103265
Version	01V30.001
HW Revision	01

Info

Here product name, order number, serial number, firmware version and hardware state number of the according module are listed.

Data

At *Data* the states of the inputs respectively outputs are listed.

Parameter

If available the parameter data of the corresponding module may be shown and possibly be changed.

Diagnosis

If available the diagnosis data of the selected module can be shown here.

4.7 Virtual memory

Values are transferred in little-endian format, i.e. least significant byte first. These areas are only readable with the ID_RD command code. ↵ 73

Virtual memory has the following structure.

ID area

ID codes	Address	Byte size	Description	Value
-	0000 0000h	4	Reserved	All 0
01h	0000 0004h	4	Vendor ID code	0000 075Ch
02h	0000 0008h	4	Device code	0A04 0C04h
03h	0000 000Ch	4	Device version	0000 0100h
04h	0000 0010h	4	Device definition file version	0000 1000h
05h	0000 0014h	4	Extended address	1 - 9 (Depends on constitution of the modules)
-	0000 0018h	32	Serial no.	Not supported (0 fix)
-	0000 0038h	4	Reserved	0000 0000h
-	0000 003Ch	4	Reserved	0000 0000h
10h	0000 0040h	4	Profile type1	0000 0030h (standard I/O)
11h	0000 0044h	4	Profile version 1	0000 0100h
12h	0000 0048h	4	Profile type 2	0000 00FFh
13h	0000 004Ch	4	Profile version 2	0000 0000h
14h	0000 0050h	4	Profile type 3	0000 00FFh
15h	0000 0054h	4	Profile version 3	0000 0000h
16h	0000 0058h	4	Minimum transmission cycle	12500 (125µs) *
17h	0000 005Ch	4	Maximum transmission cycle	800000 (8ms)
18h	0000 0060h	4	Granularity of transmission cycle	0000 0003h The following values are supported: 125µs, 250µs, 500µs, 750µs, 1...32ms in steps of 0.5ms
19h	0000 0064h	4	Minimum communication cycle	12500 (125µs) *
1Ah	0000 0068h	4	Maximum communication cycle	3200000 (32ms)
1Bh	0000 006Ch	4	Number of transmission bytes	0000 0002h (for bus coupler) 0000 0010h (for peripheral module)
1Ch	0000 0070h	4	Number of transmission bytes (current value)	0000 0002h (for bus coupler) 0000 0010h (for peripheral module)
1Dh	0000 0074h	4	Profile type (current value)	The profile specified by the CONNECT command is output: 0030h at cyclical communication 0001h at acyclic communication
-	0000 0078h	4	Reserved	All 0
-	0000 007Ch	4	Reserved	All 0

Virtual memory

ID codes	Address	Byte size	Description	Value
20h	0000 0080h	4	Supported communication mode	0000 0007h The following modes are supported: Message mode, cyclic and event driven mode
-	0000 0084h	10	MAC address	Not supported (All 0)
-	0000 008Ch	52	Reserved	All 0
30h	0000 00C0h	32	List of supported main commands	0000 0003 6000 E079h The following commands are supported: NOP, ID_RD, CONFIG, ALM_RD, ALM_CLR, SYNC_SET, CONNECT, DISCONNECT, DATA_RWA, DATA_RWS
38h	0000 00E0h	32	List of supported subcommands	All 0
40h	0000 0100h	32	List of supported common parameters	All 0
-	0000 0120h	96	Reserved	All 0
60h	0000 0180	32	List of supported MECHATROLINK message communication sub functions	000E 0000 0002 0042h The following sub functions are supported: memory read, read max. message size, download request, download data, download complete
68h	0000 01A0h	4	Message relay support	0003 0001h The 3-step message relay is supported.
69h	0000 01A4h	4	Timeout period	5 (5s)
6Ah	0000 01A8h	4	Timeout period (for file access commands)	5 (5s)
-	0000 01ACh	84	Reserved	All 0
80h	0000 0200h	32	Name of main device	"IM 053ML"
-	0000 0220h	32	Reserved	All 0
-	0000 0240h	32	Name of sub device 1	Not supported (All 0)
-	0000 0260h	4	Version of sub device 1	Not supported (All 0)
-	0000 0264h	28	Reserved	All 0
-	0000 0280h	32	Name of sub device 2	Not supported (All 0)
-	0000 02A0h	4	Version of sub device 2	Not supported (All 0)
-	0000 02A4h	28	Reserved	All 0
-	0000 02C0h	32	Name of sub device 3	Not supported (All 0)
-	0000 02E0h	4	Version of sub device 3	Not supported (All 0)
-	0000 02E4h	28	Reserved	All 0

*) This value depends on the processing of the corresponding module. 125µs are only possible in asynchronous mode.

Vendor specific area

Address	Byte size	Description	Value
0000 0300h	4	Using number of slot	0 - 64
0000 0304h	28	Reserved	All 0
0000 0320h	32	Slot 0 device name	"0531ML00"

Address	Byte size	Description	Value
0000 0340h	4	Slot 0 input extended address	0
0000 0344h	4	Slot 0 input data start offset	0
0000 0348h	4	Slot 0 input data byte size	12
0000 034Ch	4	Slot 0 output extended address	0
0000 0350h	4	Slot 0 output data start offset	0
0000 0354h	4	Slot 0 output data byte size	12
0000 0358h	4	Slot 0 parameter data size	0
0000 035Ch	4	Reserved	All 0
0000 0360h	32	Slot 1 device name	Value depends on device
0000 0380h	4	Slot 1 input extended address	Value depends on device
0000 0384h	4	Slot 1 input data start offset	Value depends on device
0000 0388h	4	Slot 1 input data byte size	Value depends on device
0000 038Ch	4	Slot 1 output extended address	Value depends on device
0000 0390h	4	Slot 1 output data start offset	Value depends on device
0000 0394h	4	Slot 1 output data byte size	Value depends on device
0000 0398h	4	Slot 1 parameter data size	Value depends on device
0000 039Ch	4	Reserved	All 0
...
0000 1320h	32	Slot 64 device name	Value depends on device
0000 1340h	4	Slot 64 input extended address	Value depends on device
0000 1344h	4	Slot 64 input data start offset	Value depends on device
0000 1348h	4	Slot 64 input data byte size	Value depends on device
0000 134Ch	4	Slot 64 output extended address	Value depends on device
0000 1350h	4	Slot 64 output data start offset	Value depends on device
0000 1354h	4	Slot 64 output data byte size	Value depends on device
0000 1358h	4	Slot 64 parameter data size	Value depends on device

Module information area

Address	Byte size	Description
8000 0000h	256	Slot 0 module information (coupler)
8000 0100h	256	Slot 1 module information
8000 0200h	256	Slot 2 module information
...
8000 3F00h	256	Slot 63 module information
8000 4000h	256	Slot 64 module information

Virtual memory

Address information slot x

Address offset	Description	Size	Value example
+0000h	Device name	32	"YASKAWA 053xxxxx"
+0020h	HW version	8	"Vxxxx"
+0028h	FPGA version	8	"V105"
+0030h	SW version	16	"V1.0.0.0"
+0040h	Serial number	32	"12345678"
+0060h	MxFile	16	"Mx000060.105"
+0070h	Product version	16	"V1.2.3.4"
+0080h	Order code	16	"053xxxxx"
+0090h	Module ID	4	12345678h
+0094h	-	108	All 0

Parameter data area

Address	Byte size	Description
8000 5000h	256	Reserved
8000 5100h	256	Slot 1 parameter, depends on module specification.
8000 5200h	256	Slot 2 parameter, depends on module specification.
...
8000 8F00h	256	Slot 63 parameter, depends on module specification.
8000 9000h	256	Slot 64 parameter, depends on module specification.

Diagnostic data area

Address	Byte size	Description
8000 A000h	4byte	Cycle over counter <ul style="list-style-type: none"> ■ Initial value is 0 ■ The counter is incremented if the time for the data exchange is greater than the time for the transmission. ■ If there are timeouts, you must increase the cycle time for data transmission.
8000 A004h	4byte	Current process time for data exchange [μs]
8000 A008h	4byte	Maximum process time for data exchange [μs]
8000 A00Ch	4byte	Reserved
8000 A010h	4byte	Coupler status <ul style="list-style-type: none"> ■ Bit 0: Coupler command error ■ Bit 1: Coupler command busy ■ Bit 2 ... 3: reserved ■ Bit 4: Cycle over error ■ Bit 5 ... 31: reserved

Address	Byte size	Description
8000 A014h	4byte	Last diagnostics message <ul style="list-style-type: none"> Initial value is 0 Please note that some diagnostic messages may be triggered due to an outdated firmware version. Diagnostic messages ↗ 62
8000 A018h	104byte	Reserved
8000 A080h	4byte	Hardware interrupt counter <ul style="list-style-type: none"> Initial value is 0 With each process interrupt, the counter is incremented by 1. With the command <i>Reset diagnostic data</i> (0x03) the counter can be reset. ↗ Chap. 4.5 'I/O area of the IM 053ML' page 52
8000 A084h	4byte	Diagnostic interrupt counter <ul style="list-style-type: none"> Initial value is 0 With each diagnostics interrupt, the counter is incremented by 1. With the command <i>Reset diagnostic data</i> (0x03) the counter can be reset. ↗ Chap. 4.5 'I/O area of the IM 053ML' page 52
8000 A088h	8byte	Hardware interrupt status <ul style="list-style-type: none"> Bit 0: Slot 1 Bit 1: Slot 2 ... Bit 63: Slot 64 With the command <i>Reset diagnostic data</i> (0x03) the status can be reset. ↗ Chap. 4.5 'I/O area of the IM 053ML' page 52
8000 A090h	8byte	Diagnostics interrupt status <ul style="list-style-type: none"> Bit 0: Slot 1 Bit 1: Slot 2 ... Bit 63: Slot 64 With each PowerON a diagnostic interrupt is generated. With the command <i>Reset diagnostic data</i> (0x03) the status can be reset. ↗ Chap. 4.5 'I/O area of the IM 053ML' page 52
8000 A098h	8byte	Reserved
8000 A0A0h	16byte	Hardware interrupt data of slot 1
8000 A0B0h	16byte	Hardware interrupt data of slot 2
...
8000 A490h	16byte	Hardware interrupt data of slot 64
8000 A4A0h	32byte	Diagnostic data of slot 1
8000 A4C0h	32byte	Diagnostic data of slot 2
8000 A4E0h	32byte	Diagnostic data of slot 3
...	...	:
8000 AC80h	32byte	Diagnostic data of slot 64
8000 ACA0h	4byte	1. (latest) diagnostics entry
...
8000 ACDCh	4byte	16. diagnostics entry

Alarms and warnings

Diagnostic messages

Code	Description
E000 00YYh	Error at access to the module at slot YY. Please retry after reboot.
E010 00YYh	Error accessing the retentive memory of the module at slot YY. Please try again after a restart respectively delete the parameters in the retentive memory and restart or carry out a firmware update.
A000 00YYh	The module version on slot YY is not supported.
A010 00YYh	
A020 00YYh	The assembled module in slot YY does not match the configured module in the retentive memory.
A030 00YYh	The module in slot YY has been configured and stored in retentive memory but not mounted.
A040 00YYh	Error writing parameter of the module at slot YY. Check your module parameters.

4.8 Alarms and warnings

Alarm list

Category	Alarm code	COMM_ ALM	Meaning	Remedy
Communication setting error	0E41h	0	<p>The received data size does not match the data size at the local station. After the start of the communication, the status of data reception is abnormal.</p> <ul style="list-style-type: none"> ■ Alarm acknowledgement: possible ■ Output behavior: All is 0 	Check the number of transmission bytes. Check the communication setting of the controller.
Communication establishment error	0E40h	B	<p>When receiving a CONNECT command, an unsupported transfer cycle was set.</p> <ul style="list-style-type: none"> ■ Alarm acknowledgement: impossible ■ Output behavior: All is 0 	Check the communication cycle setting of the controller.
Communication error	0E60h	9	<p>Data reception errors occurred twice in a row after the execution of the CONNECT command was completed. (Influence of noise etc.)</p> <ul style="list-style-type: none"> ■ Alarm acknowledgement: possible ■ Output behavior: All is 0 	Check the communication settings of the controller. Take countermeasures against faults. To clear the alarm state, send the command ALM_CLR. If the alarm persists, replace the coupler.
	0E62h	8	<p>FCS errors occurred twice in a row after completing the CONNECT command. (Influence of noise etc.)</p> <ul style="list-style-type: none"> ■ Alarm acknowledgement: possible ■ Output behavior: All is 0 	Check the communication settings of the controller. Take countermeasures against faults. To clear the alarm state, send the command ALM_CLR.

Category	Alarm code	COMM_ ALM	Meaning	Remedy
	0E63h	A	The synchronous frame not received state was detected twice consecutively after completing the execution of the CONNECT command. (Influence of noise etc.) <ul style="list-style-type: none"> ■ Alarm acknowledgement: possible ■ Output behavior: All is 0 	
System error	0B6Ah	0	The initialization process of the communication LSI failed. <ul style="list-style-type: none"> ■ Alarm acknowledgement: impossible ■ Output behavior: All is 0 	Replace the coupler.

List of Warnings - Communication error (COMM_ALM)

Category	Warning Code	COMM_ ALM	Meaning	Remedy
Communication warnings	0960h	2	Communication error <ul style="list-style-type: none"> ■ Alarm acknowledgement: necessary ■ Output behavior: Values still remain 	Check the communication settings. Take countermeasures against faults.
	0962h	1	FCS error <ul style="list-style-type: none"> ■ Alarm acknowledgement: necessary ■ Output behavior: Values still remain 	
	0963h	3	The time for the cyclic data exchange has exceeded the time for the data transfer. <ul style="list-style-type: none"> ■ Alarm acknowledgement: necessary ■ Output behavior: Values still remain 	Increase the cycle time for data transfer.

List of Warnings - Command error (CMD_ALM)

Category	Warning code	CMD_ALM	Meaning	Remedy
Warning for data setting	094Ah	9	Parameter numbers or data addresses are faulty. <ul style="list-style-type: none"> ■ Alarm acknowledgement: automatic ■ Output behavior: Values still remain 	Check the contents of the command data sent by the controller. (Check the setting for each command and parameter.)
	094Bh	9	The data in the command are invalid. <ul style="list-style-type: none"> ■ Alarm acknowledgement: automatic ■ Output behavior: Values still remain 	
Command warning	095Bh	8	An unsupported command was received. <ul style="list-style-type: none"> ■ Alarm acknowledgement: automatic ■ Output behavior: Values still remain 	Check the command transmission sequence of the controller. (See the conditions for each command.)

Alarms and warnings

Category	Warning code	CMD_ALM	Meaning	Remedy
	095Fh	8	An invalid command was received. <ul style="list-style-type: none">■ Alarm acknowledgement: automatic■ Output behavior: Values still remain	
	097Ah	C	A command that is not allowed in this communication phase has been received. <ul style="list-style-type: none">■ Alarm acknowledgement: automatic■ Output behavior: Values still remain	

4.9 MECHATROLINK-III specification

4.9.1 Phases of the communication

4.9.1.1 State machine

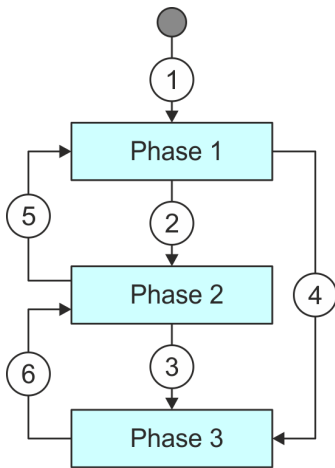

Each MECHATROLINK-III slave implements a state machine for communication. Here the following phases and transitions are defined.

- Phase 1 Device is waiting for communication set-up
 - Phase 2 Asynchronous communication - the device is in maintenance mode and can be configured.
 - Phase 3 Synchronous communication - the device is in synchronous data exchange.
- 1 Automatic transition to *phase 1* with PowerON.
 - 2 Transition to *phase 2* with CONNECT \hookrightarrow 77
 - 3 Transition to *phase 3* with SYNC_SET \hookrightarrow 77
 - 4 Transition to *phase 3* with CONNECT and set SYNCMODE \hookrightarrow 77
 - 5 Transition to *phase 1* with DISCONNECT \hookrightarrow 79
 - 6 Interrupts triggers transition to *phase 2*.

4.9.1.2 Time chart I/O data

General

- 1
- 2
- 3
- 4

In the bus coupler the following processes are executed based on transmission cycle.

- 1 Network process
- 2 Output to modules
- 3 Input from modules
- 4 Internal process

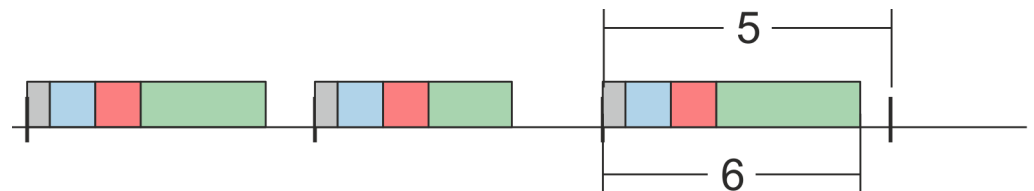

- 5 Transmission cycle
- 6 Process time

Process time exceeds transmission time

In case of the process time exceeds the transmission time (called cycle over), the next cycle is skipped and the process is executed again by the next transmission interrupt.

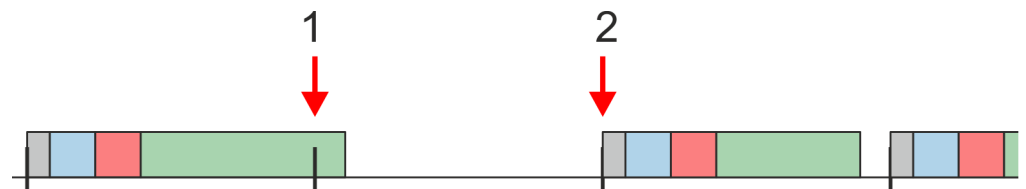

- 1 Transmission cycle exceeds process time - the next cycle is skipped.
- 2 Process is executed by next transmission interrupt

Behavior of the input data If cycle over occurred, the input data are delayed one transmission cycle.

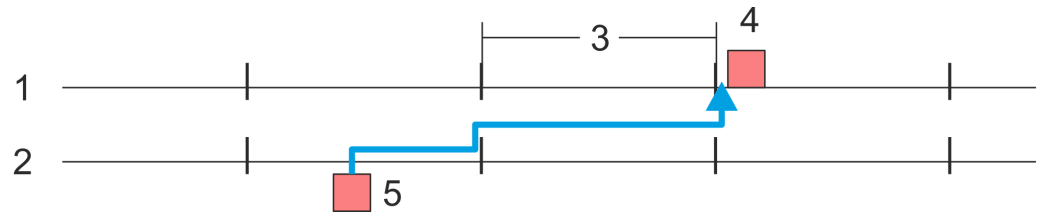

- 1 *MECHATROLINK-III* master
- 2 *MECHATROLINK-III* coupler
- 3 Transmission cycle
- 4 Application detects input
- 5 Input from modules

Behavior of the output data If cycle over occurred, the output data are delayed one transmission cycle.

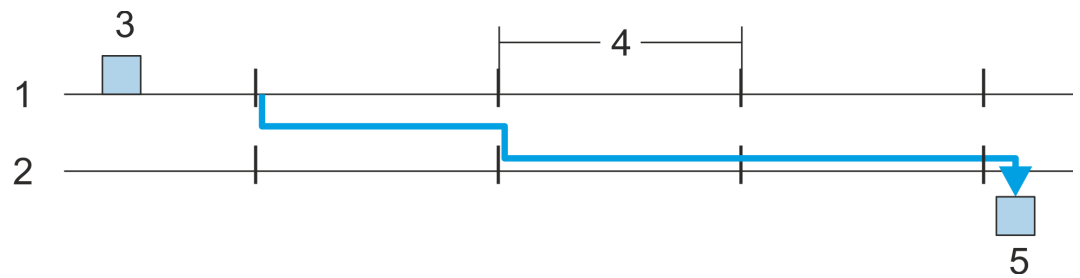

- 1 *MECHATROLINK-III* master
- 2 *MECHATROLINK-III* coupler
- 3 Output value in application is set
- 4 Transmission cycle
- 5 Output at module

Asynchronous communication In asynchronous communication (phase 2), the communication is not influenced by a cycle over. The transmission cycle can be smaller than the maximum process time.

Synchronous communication In synchronous communication (phase 3), with an cycle over a warning is triggered (A.980) and the phase is changed to phase 2. To avoid this you have to preset the transmission cycle time, which is bigger than the maximum process time.

4.9.2 Standard IO profile

4.9.2.1 Standard I/O profile command format

4.9.2.1.1 Overview

The MECHATROLINK-III communication specifications specify the standard I/O profile for data exchange with the System SLIO. The following table shows the command types, which are applied in the standard I/O profile and indicates whether the command is supported by the corresponding System SLIO module.

Byte	Command	Response	Reference
0	CMD	RCMD	↪ Chap. 4.9.2.1.2 'Command Code (CMD/RCMD)' page 67
1	WDT	RWDT	↪ Chap. 4.9.2.1.3 'Watchdog Data (WDT/RWDT)' page 68
2	CMD_CTRL	CMD_STAT	↪ Chap. 4.9.2.1.4 'Command Control (CMD_CTRL)' page 68
3			↪ Chap. 4.9.2.1.5 'CMD_STAT' page 69
4 ... 63	CMD_DATA	RSP_DATA	↪ Chap. 4.9.4 'Command detail' page 73

4.9.2.1.2 Command Code (CMD/RCMD)

The following table lists the commands, which are applied in the standard I/O profile and indicates, whether or not each command is supported by the System SLIO.

Profile	Command Code	Command	Operation	Supported by System SLIO
Common commands	00h	NOP	No operation ↪ 73	Yes
	01h	PRM_RD	Read parameter	No
	02h	PRM_WR	Write parameter	No
	03h	ID_RD	Read ID ↪ 73	Yes
	04h	CONFIG	Device setup request ↪ 74	Yes
	05h	ALM_RD	Read alarm/warning ↪ 75	Yes
	06h	ALM_CLR	Clear alarm/warning state ↪ 76	Yes
	0Dh	SYNC_SET	Request for establishing synchronization ↪ 77	Yes
	0Eh	CONNECT	Request for establishing connection ↪ 77	Yes
	0Fh	DISCONNECT	Request for releasing connection ↪ 79	Yes
	1Bh	PPRM_RD	Read memory	No
	1Ch	PPRM_WR	Write memory	No
	1Dh	MEM_RD	Read stored parameter ↪ 79	Yes
1Eh	MEM_WR	Write stored parameter ↪ 81	Yes	
Standard I/O commands	20h	DATA_RWA	Data read/write command (asynchronous) ↪ 82	Yes
	21h	DATA_RWS	Data read/write command (synchronous) ↪ 83	Yes

4.9.2.1.3 Watchdog Data (WDT/RWDT)

During synchronous communications, the C1 master station exchanges synchronous data with its slave stations every communication cycle. These synchronous data are called watchdog data. Watchdog data are used for the detection of synchronous communication establishment and imperfect synchronization.

Data format

The *WDT* and *RWDT* field of the C1 master station and each slave station are used. MN data come from C1 master and RSN data from slave station. The data format of each field is as shown below.

WDT - Command data

Bit 7 ... Bit 4	Bit 3 ... Bit 0
SN: The <i>RSN</i> value of <i>RWDT</i> to be copied	MN: Incremented by one for each communication

RWDT - Response data

Bit 7 ... Bit 4	Bit 3 ... Bit 0
RSN: Incremented by one for each communication	MN value of <i>WDT</i> to be copied

Error detection

If the watchdog data of the remote station is other than the previous value incremented by 1 during the synchronous communication, an error will be detected except in the following cases:

- The C1 master station transmits a *DISCONNECT* command, as request to release connection, in the next communication cycle.
- A communication error or transmission error has already been detected.

4.9.2.1.4 Command Control (CMD_CTRL)

The following describes the 2 bytes *CMD_CTRL* as part of the MECHATROLINK-III command format. The *CMD_CTRL* area is specified as shown below by the communication specification. Note that the designation in this field is valid even when a *CMD_ALM* has occurred.

CMD_CTRL

Bit 15 ... 8	Bit 7 ... 6	Bit 5 ... 4	Bit 3	Bit 2 ... 0
Reserved	CMD_ID	Reserved	ALM_CLR	Reserved

ALM_CLR: Clear communication alarm/warning

Value	Reference
0	Clear alarm/warning disabled.
1	Clear alarm/warning triggered.

- Clears the alarm/warning state with edge 0-1.
- The same processing as when *ALM_CLR_MODE* = 0 for the *ALM_CLR* command (the current alarm/warning state is cleared) is performed.
- The *ALM_CLR* bit is used effectively to clear the *COMM_ALM* warning state.

CMD_ID: Command ID

- This is not used with standard I/O profile commands.

4.9.2.1.5 CMD_STAT

The following describes the 2 bytes *CMD_STAT* as part of the MECHATROLINK-III command format. The *CMD_STAT* area is specified as shown below by the communication specification. Note that the designation in this field is valid even when a *CMD_ALM* has occurred.

Bit 15 ... 12	Bit 11 ... 8	Bit 7 ... 6	Bit 5 ... 4	Bit 3	Bit 2	Bit 1	Bit 0
COMM_ALM	CMD_ALM	RCMD_ID	Reserved	ALM_CLR_CMP	CMDRDY	D_WAR	D_ALM

D_ALM

Value	Reference
1	The device is in the alarm state.
0	Other (includes the states corresponding to <i>COMM_ALM</i> or <i>CMD_ALM</i>)

- When a device-specific alarm other than the alarm state specified by *COMM_ALM* and *CMD_ALM* has occurred, the *D_ALM* status bit is set to 1.
- *D_ALM* is independent of *COMM_ALM* and *CMD_ALM*.
- When the slave station shifts from the device alarm state to the normal state as a result of the execution of the *ALM_CLR* command and *CMD_CTRL.ALM_CLR*, this bit is set to 0.

D_WAR

Value	Reference
1	The device is in the warning state.
0	Other (includes the states corresponding to <i>COMM_ALM</i> or <i>CMD_ALM</i>)

- The bit that indicates the device warning state of the slave station. When a device-specific warning other than the warning state specified by *COMM_ALM* or *CMD_ALM* has occurred, the *D_WAR* status bit is set to 1.
- *D_WAR* is independent of *COMM_ALM* and *CMD_ALM*.
- When the slave station shifts from the device warning state to the normal state as a result of the execution of the *ALM_CLR* command and *CMD_CTRL.ALM_CLR*, this bit is set to 0.

CMDRDY

Value	Reference
1	Command reception enabled.
0	Other

- *CMDRDY* = 0 means that command processing is in progress. While *CMDRDY* = 0, the System SLIO continues to process the current command, so the System SLIO will discard new commands received while *CMDRDY* = 0.
- Only the *DISCONNECT* command is executed immediately regardless of the *CMDRDY* value.
- Completion of command execution is confirmed in accordance with the completion confirmation method of each command.
- The hold time for *CMDRDY* = 0 is specified by individual commands.
- If command execution is possible despite an alarm or warning state, *CMDRDY* is set to 1.

ALM_CLR_CMP

Value	Reference
1	Completion of execution of <i>ALM_CLR</i> .
0	Other

- *ALM_CLR_CMP* = 1 means that *CMD_CTRL.ALM_CLR* = 1 has been received and alarm clear processing has been completed.
- *ALM_CLR_CMP* can be cancelled by setting "0" for *CMD_CTRL.ALM_CLR*.

RCMD_ID

- This is not used in the standard I/O profile.

CMD_ALM

Code	Contents	Remark	
0	Normal	-	
Warning	1	-	These do not occur with this module.
	2	-	
	3	-	
	4	-	
	5	-	
	6	-	
	7	-	
Alarm	8	Unsupported command received	System SLIO notifies the alarm state and the command is not executed.
	9	Invalid data	
	A	-	
	B	-	
	C	Phase error	
	D	-	
	E	-	
F	-		

Notifies the command error state.

- The code that indicates a command error. *CMD_ALM* is independent of *COMM_ALM*, *D_ALM* and *D_WAR*.
- If a normal command is received after the occurrence of a command error, *CMD_ALM* is automatically cleared.
- The phase doesn't change even if the status of *CMD_ALM* is not "0". ↪ *Chap. 4.9.1 'Phases of the communication' page 65*

COMM_ALM

Code	Contents	Remark	
0	Normal	-	
Warning	1	FCS error	Occurs when an error is detected once.
	2	Command data not received	
	3	Synchronous frame not received	
	4	-	
	5	-	
	6	-	
	7	-	
Alarm	8	FCS error	Occurs if an error is detected twice consecutively using the error detection method for warning 1, described above.
	9	Command data not received	
	A	Synchronous frame not received	
	B	Synchronization time interval error	
	C	Phase error	
	D	WDT error	
	E	-	
F	-		

Notifies the command error state.

- The code that indicates the error state of MECHATROLINK-III communication.
- *COMM_ALM* is cleared with edge 0-1 of *CMD_CTRL.ALM_CLR* or by the *ALM_CLR* command.

4.9.2.1.6 Command to extended address

When the following commands are commanded to any extended addresses, they are all processed as commands to the coupler module. If you want to command to peripheral modules, you have to use the *Coupler command* area. ↪ *Chap. 4.5 'I/O area of the IM 053ML' page 52*

- The commands that are processed on extended address
 - NOP
 - CONNECT
 - DISCONNECT
- The commands that are processed as the command of coupler module
 - ID_RD
 - CONFIG
 - ALM_RD
 - ALM_CLR
 - SYNC_SET
 - MEM_RD
 - MEM_WR

4.9.3 ID information acquisition profile

Data format

Byte	Command	Response	Reference
0	CMD	RCMD	↪ <i>Chap. 4.9.3.1 'Command Code (CMD/RCMD)' page 72</i>
1	WDT	RWDT	This function is currently not supported.
2	CMD_CTRL	CMD_START	↪ <i>Chap. 4.9.2.1.4 'Command Control (CMD_CTRL)' page 68</i>
3			↪ <i>Chap. 4.9.2.1.5 'CMD_STAT' page 69</i>
4 ... 15	CMD_DATA	RSP_DATA	↪ <i>Chap. 4.9.3.1 'Command Code (CMD/RCMD)' page 72</i>

4.9.3.1 Command Code (CMD/RCMD)

The following table shows the command types, which are applied in the ID information acquisition profile and indicates whether the command is supported by the corresponding System SLIO module.

Command code	Command	Operation	Supported by System SLIO
00h	NOP	No operation ↪ 73	Yes
03h	ID_RD	Read ID ↪ 73	Yes
0Eh	CONNECT	Request for establishing connection ↪ 77	Yes
0Fh	DISCONNECT	Request for releasing connection ↪ 79	Yes
1Dh	MEM_RD	Read stored parameter ↪ 79	No

4.9.4 Command detail

4.9.4.1 No operation command *NOP* (00h)

The *NOP* command is used for network control. The current state is returned as a response.

Confirmation of completion

- Confirm that *RCMD* = *NOP* (00h) and *CMD_STAT.CMDRDY* = 1.
- When *CMD_STAT.D_ALM* or *CMD_STAT.D_WAR* = 1, use *ALM_RD* to read out the current alarm code and take appropriate action.
- When *CMD_STAT.CMD_ALM* or *CMD_STAT.COMM_ALM* ≠ 1, take appropriate action according to the codes. ↪ *Chap. 4.9.2.1.5 'CMD_STAT' page 69*

Command classification

- Device group: Common command group
- Communication type: Asynchronous communication command

Data format

Byte	Command	Response	Reference
0	NOP (00h)	NOP (00h)	
1	WDT	RWDT	↪ <i>Chap. 4.9.2.1.3 'Watchdog Data (WDT/RWDT)' page 68</i>
2	CMD_CTRL	CMD_STAT	↪ <i>Chap. 4.9.2.1.4 'Command Control (CMD_CTRL)' page 68</i>
3			↪ <i>Chap. 4.9.2.1.5 'CMD_STAT' page 69</i>
4 ... 63	Reserved (0)	Reserved (0)	

4.9.4.2 Read ID command *ID_RD* (03h)

The *ID_RD* command is used to read the ID of a device. This command reads the product information as ID data. The ID data is selected in detail by specifying *ID_CODE*.

Confirmation of completion

- Confirm that *RCMD* = *ID_RD* (03h) and *CMD_STAT.CMDRDY* = 1 and also the setting for *ID_CODE*, *OFFSET* and *SIZE* of the response.
- When *CMD_STAT.D_ALM* or *CMD_STAT.D_WAR* = 1, use *ALM_RD* to read out the current alarm code and take appropriate action.
- When *CMD_STAT.CMD_ALM* or *CMD_STAT.COMM_ALM* ≠ 0, take appropriate action according to the codes. ↪ *Chap. 4.9.2.1.5 'CMD_STAT' page 69*

Command classification

- Device group: Common command group
- Communication type: Asynchronous communication command

Data format

Byte	Command	Response	Reference
0	ID_RD (03h)	ID_RD (03h)	
1	WDT	RWDT	↪ <i>Chap. 4.9.2.1.3 'Watchdog Data (WDT/RWDT)' page 68</i>
2	CMD_CTRL	CMD_STAT	↪ <i>Chap. 4.9.2.1.4 'Command Control (CMD_CTRL)' page 68</i>
3			↪ <i>Chap. 4.9.2.1.5 'CMD_STAT' page 69</i>
4	ID_CODE	ID_CODE	ID_Code ↪ <i>Chap. 4.7 'Virtual memory' page 57</i>

Byte	Command	Response	Reference
5	OFFSET	OFFSET	<ul style="list-style-type: none"> Can be used in <i>phases 2 and 3</i>. ↪ <i>Chap. 4.9.1 'Phases of the communication' page 65</i> When the <i>ID_CODE</i> data is invalid, 9h is set for <i>CMD_ALM</i>. When the <i>OFFSET</i> data is invalid, 9h is set for <i>CMD_ALM</i>. When the <i>SIZE</i> data does not match, 9h is set for <i>CMD_ALM</i>. When <i>CMD_ALM</i> = 9h occurs, the ID becomes an indefinite value.
6	SIZE	SIZE	
7			
8 ... 63	Reserved (0)	ID	

4.9.4.3 Setup device command CONFIG (04h)

This command is used to set up devices. The contents of the processing to be executed are specified by the product specifications. A product that does not have the corresponding functions must immediately return a response for process completion.

Confirmation of completion

- Confirm that *RCMD* = *CONFIG* (04h) and *CMD_STAT.CMDRDY* = 1 and also the setting for the *CONFIG_MOD* of the response.
- When *CMD_STAT.D_ALM* or *CMD_STAT.D_WAR* = 1, use *ALM_RD* to read out the current alarm or warning codes and take appropriate action.
- When *CMD_STAT.CMD_ALM* or *CMD_STAT.CMD_COMM* ≠ 0, take appropriate action according to the codes. ↪ *Chap. 4.9.2.1.5 'CMD_STAT' page 69*

Command classification

- Device group: Common command group
- Communication type: Asynchronous communication command

Data format

Byte	Command	Response	Reference
0	CONFIG (04h)	CONFIG (04h)	
1	WDT	RWDT	↪ <i>Chap. 4.9.2.1.3 'Watchdog Data (WDT/RWDT)' page 68</i>
2	CMD_CTRL	CMD_STAT	↪ <i>Chap. 4.9.2.1.4 'Command Control (CMD_CTRL)' page 68</i>
3			↪ <i>Chap. 4.9.2.1.5 'CMD_STAT' page 69</i>
4	CONFIG_MOD	CONFIG_MOD	<ul style="list-style-type: none"> Can be used in <i>phases 2 and 3</i>. ↪ <i>Chap. 4.9.1 'Phases of the communication' page 65</i> When the <i>CONFIG_MOD</i> data is invalid, 9h is set for <i>CMD_ALM</i>.
5 ... 63	Reserved (0)	ID	

CONFIG_MOD: Configuration mode

Value	Reference
0	Parameter re-calculation and setup
1	Common parameter batch writing into nonvolatile memory (not supported)
2	Parameter initialization to factory defaults

Status during execution of CONFIG command

Status	Before Execution	During Execution	After Execution
ALM	current status	current status	current status
CMDRDY	1	0	1
Other	current status	not defined	current status

- The table shows each status before, during, and after the execution of *CONFIG* command.

4.9.4.4 Read alarm or warning command ALM_RD (05h)

The *ALM_RD* command is used to read the alarm or warning state. The current alarm or warning state is read to *ALM_DATA* as an alarm or warning code.

Confirmation of completion

- Confirm that *RCMD* = *ALM_RD* (05h) and *CMD_STAT.CMDRDY* = 1 and also the setting for the *ALM_RD_MOD* and *ALM_INDEX* of the response.

Command classification

- Device group: Common command group
- Communication type: Asynchronous communication command

Data format

Byte	Command	Response	Reference
0	ALM_RD (05h)	ALM_RD (05h)	
1	WDT	RWDT	↪ Chap. 4.9.2.1.3 'Watchdog Data (WDT/RWDT)' page 68
2	CMD_CTRL	CMD_STAT	↪ Chap. 4.9.2.1.4 'Command Control (CMD_CTRL)' page 68
3			↪ Chap. 4.9.2.1.5 'CMD_STAT' page 69
4	ALM_RD_MOD	ALM_RD_MOD	<ul style="list-style-type: none"> ■ Can be used in phases 2 and 3. ↪ Chap. 4.9.1 'Phases of the communication' page 65 ■ If the <i>ALM_RD_MOD</i> data is invalid, 9 is set for <i>CMD_ALM</i>. ■ If the <i>ALM_INDEX</i> data is invalid, 9 is set for <i>CMD_ALM</i>.
5			
6	ALM_INDEX	ALM_INDEX	
7			
9 ... 63	Reserved (0)	ALM_DATA	

ALM_RD_MOD: Read mode

Value	Reference
0	<ul style="list-style-type: none"> ■ Reads the current alarm/warning state ■ Max. 12 alarms/warnings (2 bytes / 1 alarm or warning, byte 8 to 31) ■ When the number of alarms/warnings is less than 12, 0 is set to the <i>ALM_DATA</i> part where there is no alarm/warning.
1	<ul style="list-style-type: none"> ■ Reads the alarm/warning history ■ Max. 12 records (2 bytes / record, byte 8 to 31) ■ When the number of alarm/warning records is less than 12, 0 is set to the <i>ALM_DATA</i> part where there is no alarm/warning.

Value	Reference
2	Individually reads the current alarm/warning details (not supported).
3	Individually reads the alarm/warning history details (not supported).

- *ALM_INDEX*: Alarm index (not supported)
Set to 0.
- *ALM_DATA*: Alarm/warning code

4.9.4.5 Clear alarm or warning command *ALM_CLR* (06h)

The *ALM_CLR* command is used to clear the alarm or warning state. It changes the state of a slave station, but does not eliminate the cause of the alarm or warning. *ALM_CLR* should be used to clear the state after the cause of the alarm or warning has been eliminated. When a communication error (reception error) or synchronous communication error (watchdog data error) occurs during synchronous communications, use *SYNC_SET* to restore synchronous communications after executing *ALM_CLR*.

Confirmation of completion

- Confirm that *RCMD* = *ALM_CLR* (06h) and *CMD_STAT.CMDRDY* = 1 and also the setting for the *ALM_CLR_MOD* of the response.
- When *CMD_STAT.D_ALM* or *CMD_STAT.D_WAR* = 1, use *ALM_RD* to read out the current alarm code and take appropriate action.
- When *CMD_STAT.CMD_ALM* or *CMD_STAT.COMM_ALM* ≠ 0, take appropriate action according to the codes. ↪ [Chap. 4.9.2.1.5 'CMD_STAT' page 69](#)

Command classification

- Device group: Common command group
- Communication type: Asynchronous communication command

Data format

Byte	Command	Response	Reference
0	<i>ALM_CLR</i> (06h)	<i>ALM_CLR</i> (06h)	
1	WDT	RWDT	↪ Chap. 4.9.2.1.3 'Watchdog Data (WDT/RWDT)' page 68
2	<i>CMD_CTRL</i>	<i>CMD_STAT</i>	↪ Chap. 4.9.2.1.4 'Command Control (CMD_CTRL)' page 68
3			↪ Chap. 4.9.2.1.5 'CMD_STAT' page 69
4	<i>ALM_CLR_MOD</i>	<i>ALM_CLR_MOD</i>	<ul style="list-style-type: none"> ■ Can be used in <i>phases</i> 2 and 3. ↪ Chap. 4.9.1 'Phases of the communication' page 65 ■ If the <i>ALM_CLR_MOD</i> data is invalid, 9 is set for <i>CMD_ALM</i>.
5			
6 ... 63	Reserved (0)	Reserved (0)	

ALM_CLR_MOD: Clear alarm mode

Value	Reference
0	Clears the current alarm/warning state.
1	Clears the alarm/warning history.

4.9.4.6 Establish synchronous communication command SYNC_SET (0Dh)

The *SYNC_SET* command is used to start synchronous communications. Synchronous communications start at the completion of execution of this command. When synchronous communication is reset to asynchronous communication because of occurrence of an error, such as a communication error, use this command to restore the synchronous communications. Synchronization is established on the base of the edge change of the watchdog data (WDT) in this command. The C1 master station holds this command until the completion of processing of this command. After the completion of execution of this command, the watchdog data error detection will start.

Confirmation of completion

- Confirm that *RCMD* = *SYNC_SET* (0Dh) and *CMD_STAT.CMDRDY* = 1.
- When *CMD_STAT.D_ALM* or *CMD_STAT.D_WAR* = 1, use *ALM_RD* to read out the current alarm code and take appropriate action.
- When *CMD_STAT.CMD_ALM* or *CMD_STAT.COMM_ALM* ≠ 0, take appropriate action according to the codes. ↪ *Chap. 4.9.2.1.5 'CMD_STAT' page 69*

Command classification

- Device group: Common command group
- Communication type: Asynchronous communication command

Data format

Byte	Command	Response	Reference
0	SYNC_SET (0Dh)	SYNC_SET (0Dh)	
1	WDT	RWDT	↪ <i>Chap. 4.9.2.1.3 'Watchdog Data (WDT/RWDT)' page 68</i>
2	CMD_CTRL	CMD_STAT	↪ <i>Chap. 4.9.2.1.4 'Command Control (CMD_CTRL)' page 68</i>
3			↪ <i>Chap. 4.9.2.1.5 'CMD_STAT' page 69</i>
4 ... 63	Reserved (0)	Reserved (0)	<ul style="list-style-type: none"> ■ In <i>phase 3</i>, this command is ignored. ↪ <i>Chap. 4.9.1 'Phases of the communication' page 65</i> ■ When <i>COMM_ALM</i> = 8h (FCS error) or 9h (no response) occurs, send this command to restart synchronous communications.

4.9.4.7 Establish connection command CONNECT (0Eh)

The *CONNECT* command is used to establish a MECHATROLINK connection. When the command has been completed, the control of slave stations is started by means of MECHATROLINK communication.

Confirmation of completion

- Confirm that *RCMD* = *CONNECT* (0Eh) and *CMD_STAT.CMDRDY* = 1 and also the setting for *VER*, *COM_MODE*, *COM_TIM* and *PROFILE_TYPE* of the response.
- When *CMD_STAT.D_ALM* or *CMD_STAT.D_WAR* = 1, use *ALM_RD* to read out the current alarm code and take appropriate action.
- When *CMD_STAT.CMD_ALM* or *CMD_STAT.COMM_ALM* ≠ 0, take appropriate action according to the codes. ↪ *Chap. 4.9.2.1.5 'CMD_STAT' page 69*

Command classification

- Device group: Common command group
- Communication type: Asynchronous communication command

Data format

Byte	Command	Response	Reference
0	CONNECT (0Eh)	CONNECT (0Eh)	
1	WDT	RWDT	↪ Chap. 4.9.2.1.3 'Watchdog Data (WDT/RWDT)' page 68
2	CMD_CTRL	CMD_STAT	↪ Chap. 4.9.2.1.4 'Command Control (CMD_CTRL)' page 68
3			↪ Chap. 4.9.2.1.5 'CMD_STAT' page 69
4	VER	VER	<ul style="list-style-type: none"> ■ Can be used in <i>phase 1</i>. ↪ Chap. 4.9.1 'Phases of the communication' page 65 ■ In <i>phases 2</i> and <i>3</i>, this command is ignored. ■ If the <i>VER</i> data is invalid, 1 or 9 is set for <i>CMD_ALM</i>. ■ If the <i>COM_TIM</i> data is invalid, 1 or 9 is set for <i>CMD_ALM</i>. ■ If the <i>PROFILE_TYPE</i> data is invalid, 1 or 9 is set for <i>CMD_ALM</i>.
5	COM_MOD	COM_MOD	
6	COM_TIM	COM_TIM	
7	PROFILE_TYPE	PROFILE_TYPE	
8 ... 63	Reserved (0)	Reserved (0)	

- *VER*: MECHATROLINK application layer version
VER = 30h

COM_MOD: Communication mode

Bit 7	Bit 6	Bit 5	Bit 4	Bit 3	Bit 2	Bit 1	Bit 0
SUBCMD	Reserved (0)			DTMODE		SYNC-MODE	Reserved (0)

SYNCMODE: Synchronous communication setting

Value	Reference
1	Starts synchronous communications (Watchdog data error detection enabled. Possible to use synchronous communication commands.)
0	Starts asynchronous communications (Watchdog data error detection disabled. Impossible to use synchronous communication commands.)

DTMODE: Communication method

Value	Reference
00	Single transmission
01	Sequential transmission (not supported)
10	Reserved
11	Reserved

SUBCMD: Subcommand setting

Value	Reference
0	Subcommand disabled

COM_TIM: Communication cycle setting

Value	Reference
0	Sets multiples of the transmission cycle as the communication cycle. Example: The transmission cycle is 0.5 ms and the communication cycle is 2 ms, then $COM_TIM = 4$ ($2/0.5 = 4$)

- **PROFILE_TYPE**: Profile type setting
Sets the profile type to be used.
 - 00h: ID Information Acquisition Profile
 - 30h: Standard I/O profile

4.9.4.8 Release connection command DISCONNECT (0Fh)

When terminating a communication connection, the C1 master station transmits the *DISCONNECT* command for two or more communication cycles. At this time, the slave station interrupts current processing and then performs the initialization required to reestablish the connection. It then waits for the connect establishment request from the C1 master station. The *DISCONNECT* command can be sent regardless of the state of the *CMD_STAT.CMDRDY* bit. If the *DISCONNECT* command is sent when the *CMD_STAT.CMDRDY* state bit is 0, processing is interrupted and this command is processed.

Confirmation of completion

- Control with the command sending time of the C1 master station as two or more communication cycles.

Command classification

- Device group: Common command group
- Communication type: Asynchronous communication command

Data format

Byte	Command	Response	Reference
0	DISCONNECT (0Fh)	DISCONNECT (0Fh)	<ul style="list-style-type: none"> ■ Can be used in all <i>phases</i>. ↪ <i>Chap. 4.9.1 'Phases of the communication' page 65</i> ■ Upon receipt of the <i>DISCONNECT</i> command, operation shifts to <i>phase 1</i>. ■ When the control power is turned OFF at the same time the <i>DISCONNECT</i> command is sent, the response data is indefinite.
1 ... 63	Reserved (0)	Reserved (0)	

4.9.4.9 Read memory content command MEM_RD (1Dh)

The *MEM_RD* command is used to read the data on the virtual memory by specifying the starting address and the data size of the virtual memory. If the reading is not successfully completed due to an incorrect designation, such as invalid starting address or data size, a warning will be created. When a warning is detected, the warning bit and warning code are set in the response. The *ADDRESS* and *SIZE* in the response are the values specified in the command, whether or not the reading has been completed. ↪ *Chap. 4.7 'Virtual memory' page 57*

Confirmation of completion

- Confirm that *RCMD* = *MEM_RD* (1Dh), *CMD_STAT.CMDRDY* = 1 and also the setting for *ADDRESS* and *SIZE* of the response.
- When *CMD_STAT.ALM* or *CMD_STAT.WAR* = 1, use *ALM_RD* to read out the current alarm or warning code and take appropriate action.
- When *CMD_STAT.CMD_ALM* or *CMD_STAT.COMM_ALM* ≠ 0, take appropriate action according to the codes. ↪ *Chap. 4.9.2.1.5 'CMD_STAT' page 69*

Command classification

- Device group: Common command group
- Communication type: Asynchronous communication command

Data format

Byte	Command	Response	Reference
0	MEM_RD (1Dh)	MEM_RD (1Dh)	
1	WDT	RWDT	↪ <i>Chap. 4.9.2.1.3 'Watchdog Data (WDT/RWDT)' page 68</i>
2	CMD_CTRL	CMD_STAT	↪ <i>Chap. 4.9.2.1.4 'Command Control (CMD_CTRL)' page 68</i>
3			↪ <i>Chap. 4.9.2.1.5 'CMD_STAT' page 69</i>
4	Reserved (0)	Reserved (0)	<ul style="list-style-type: none"> ■ Can be used in <i>phases 2</i> and <i>3</i>. ↪ <i>Chap. 4.9.1 'Phases of the communication' page 65</i> ■ If any of the command errors below occur, 9 is set for <i>CMD_ALM</i> <ul style="list-style-type: none"> – The <i>MODE</i> data is invalid – The <i>DATA_TYPE</i> data is invalid – <i>SIZE</i> > 4 – The <i>ADDRESS</i> data is invalid. ■ For errors other than the above, an alarm can be specified in the product specifications Example: By allocating the reserved area to read alarms, etc.
5	MODE/ DATA_TYPE	MODE/ DATA_TYPE	
6	SIZE	SIZE	
7			
8 ... 63	Reserved (0)	Reserved (0)	

MODE/DATA_TYPE: Mode/Data type

Bit 7	Bit 6	Bit 5	Bit 4	Bit 3	Bit 2	Bit 1	Bit 0
MODE				DATA_TYPE			

MODE: Read mode

Value	Reference
0	Reserved by system
1	Volatile memory Reads from a volatile memory such as SRAM.
2	Nonvolatile memory (not supported) Reads from a nonvolatile memory such as E ² PROM
3 ... F	Reserved by system

DATA_TYPE: Data type

Value	Reference
0	Reserved by system
1	Byte type (not supported)
2	Short type
3	Long type
4	Long long type (not supported)
5 ... F	Reserved by system

- **SIZE:** Number of data to read
- **ADDRESS:** Starting address to read
- **DATA:** Data

4.9.4.10 Write memory content command MEM_WR (1Eh)

The *MEM_WR* command is used to write data to the virtual memory by specifying the starting address, data size, and the virtual memory date. If the writing processing is not successfully completed due to an incorrect designation such as invalid starting address and data size, a warning is created. When a warning is detected, the warning bit and warning code are set in the response. The *DATA* in the response is the value specified in the command, whether or not the writing has been completed. ↪ *Chap. 4.7 'Virtual memory' page 57*

Confirmation of completion

- Confirm that *RCMD = MEM_WR (1Eh)*, *CMD_STAT.CMDRDY = 1* and also the setting for *ADDRESS*, *SIZE* and *DATA* of the response.
- When *CMD_STAT.ALM* or *CMD_STAT.D_WAR = 1*, use *ALM_RD* to read out the current alarm or warning code and take appropriate action.
- When *CMD_STAT.CMD_ALM* or *CMD_STAT.COMM_ALM ≠ 0*, take appropriate action according to the codes. ↪ *Chap. 4.9.2.1.5 'CMD_STAT' page 69*

Command classification

- Device group: Common command group
- Communication type: Asynchronous communication command

Data format

Byte	Command	Response	Reference
0	MEM_WR (1Eh)	MEM_WR (1Eh)	
1	WDT	RWDT	↪ <i>Chap. 4.9.2.1.3 'Watchdog Data (WDT/RWDT)' page 68</i>
2	CMD_CTRL	CMD_STAT	↪ <i>Chap. 4.9.2.1.4 'Command Control (CMD_CTRL)' page 68</i>
3			↪ <i>Chap. 4.9.2.1.5 'CMD_STAT' page 69</i>
4	Reserved (0)	Reserved (0)	<ul style="list-style-type: none"> ■ Can be used in <i>phases 2</i> and <i>3</i>. ↪ <i>Chap. 4.9.1 'Phases of the communication' page 65</i> ■ If any of the command errors below occur, 9 is set for <i>CMD_ALM</i> <ul style="list-style-type: none"> – The <i>MODE</i> data is invalid – The <i>DATA_TYPE</i> data is invalid – <i>SIZE > 4</i> – The <i>ADDRESS</i> data is invalid. ■ For errors other than the above, an alarm can be specified in the product specifications
5	MODE/ DATA_TYPE	MODE/ DATA_TYPE	
6	SIZE	SIZE	
7			

Byte	Command	Response	Reference
8 ... 11	ADDRESS	ADDRESS	Example: By allocating the reserved area to read alarms, etc.
12 ... 63	DATA	DATA	

MODE/DATA_TYPE: Mode/Data type

Bit 7	Bit 6	Bit 5	Bit 4	Bit 3	Bit 2	Bit 1	Bit 0
MODE				DATA_TYPE			

MODE: Write mode

Value	Reference
0	Reserved by system
1	Volatile memory Writes to a volatile memory such as SRAM.
2	Nonvolatile memory (not supported) Writes to a nonvolatile memory such as E ² PROM
3 ... F	Reserved by system

DATA_TYPE: Data type

Value	Reference
0	Reserved by system
1	Byte type (not supported)
2	Short type
3	Long type
4	Long long type (not supported)
5 ... F	Reserved by system

- *SIZE*: Number of data to write
- *ADDRESS*: Starting address to write
- *DATA*: Data

4.9.4.11 Data READ/WRITE_A (Asynchronous) command DATA_RWA (20h)

This command updates (asynchronously) I/O data.

Confirmation of completion

- Confirm that *RCMD* = *DATA_RWA* (20h) and *CMD_STAT.CMDRDY* = 1.
- When *CMD_STAT.D_ALM* or *CMD_STAT.D_WAR* = 1, use *ALM_RD* to read out the current alarm code and take appropriate action.
- When *CMD_STAT.CMD_ALM* or *CMD_STAT.COMM_ALM* ≠ 0, take appropriate action according to the codes. ↪ *Chap. 4.9.2.1.5 'CMD_STAT' page 69*

Command classification

- Device group: I/O command group
- Communication type: Asynchronous communication command

Data format

Byte	Command	Response	Reference
0	DATA_RWA (20h)	DATA_RWA (20h)	
1	WDT	RWDT	↪ Chap. 4.9.2.1.3 'Watchdog Data (WDT/RWDT)' page 68
2	CMD_CTRL	CMD_STAT	↪ Chap. 4.9.2.1.4 'Command Control (CMD_CTRL)' page 68
3			↪ Chap. 4.9.2.1.5 'CMD_STAT' page 69
4 ... 63	OUTPUT data	INPUT data	<ul style="list-style-type: none"> ■ INPUT data are always updated. ■ Can be used in phases 2 and 3. ↪ Chap. 4.9.1 'Phases of the communication' page 65

4.9.4.12 Data READ/WRITE_S (Synchronous) command DATA_RWS (21h)

This command updates (synchronously) I/O data.

Confirmation of completion

- Confirm that $RCMD = DATA_RWS$ (21h) and $CMD_STAT.CMDRDY = 1$
- When $CMD_STAT.D_ALM$ or $CMD_STAT.D_WAR = 1$, use ALM_RD to read out the current alarm code and take appropriate action
- When $CMD_STAT.CMD_ALM$ or $CMD_STAT.COMM_ALM \neq 0$, take appropriate action according to the codes ↪ Chap. 4.9.2.1.5 'CMD_STAT' page 69

Command classification

- Device group: I/O command group
- Communication type: Synchronous communication command

Data format

Byte	Command	Response	Reference
0	DATA_RWS (21h)	DATA_RWS (21h)	
1	WDT	RWDT	↪ Chap. 4.9.2.1.3 'Watchdog Data (WDT/RWDT)' page 68
2	CMD_CTRL	CMD_STAT	↪ Chap. 4.9.2.1.4 'Command Control (CMD_CTRL)' page 68
3			↪ Chap. 4.9.2.1.5 'CMD_STAT' page 69
4 ... 63	OUTPUT data	INPUT data	<ul style="list-style-type: none"> ■ In phase 2, Ch is set for COM_ALM. ■ Can be used in phase 3. ↪ Chap. 4.9.1 'Phases of the communication' page 65

4.9.5 MECHATROLINK message communication sub functions

Sub functions

Function code	Sub function	Operation	Option
42h	01h	Memory read	-
	11h	Read max. message size	-
	31h	Download request	Only for configuration tool
	32h	Download data	Only for configuration tool
	33h	Download complete	Only for configuration tool

Sub function detail - memory read (01h)

Byte	Command	Normal response	Error response
0	Slave address	MEM_RD (1Dh)	Slave address
1	Function code (42h)	Function code (42h)	Function code (42h) + 80h (C2h)
2	Extended address	Extended address	Extended address
3	Command status	Response status	Response status
4	Sub function code (01h)	Sub function code (01h)	Sub function code (01h)
5	MODE/ DATA_TYPE (11h)	MODE/ DATA_TYPE (11h)	Error code <ul style="list-style-type: none"> ■ 02h: Address error ■ 04h: Data type error
6	Number of data bytes	Number of data bytes	Reserved (00h)
7			
8 ... n	Start address	1. data	Error detected address
...		...	
n		n. data	

MODE/DATA_TYPE: Mode/Data type

Bit 7	Bit 6	Bit 5	Bit 4	Bit 3	Bit 2	Bit 1	Bit 0
MODE				DATA_TYPE			

MODE: Read mode

Value	Reference
0	Reserved by system
1	Volatile memory Reads from a volatile memory such as SRAM
2	Nonvolatile memory (not supported) Reads from a nonvolatile memory such as E ² PROM
3 ... F	Reserved by system

DATA_TYPE: Data type

Value	Reference
0	Reserved by system
1	Byte type
2	Short type
3	Long type
4	Long long type
5 ... F	Reserved by system

Sub function detail - read max. message size (11h)

Byte	Command	Normal response	Error response
0	Slave address	MEM_RD (1Dh)	Slave address
1	Function code (42h)	Function code (42h)	Function code (42h) + 80h (C2h)
2	Extended address	Extended address	Extended address
3	Command status	Response status	Response status
4	Sub function code (11h)	Sub function code (11h)	Sub function code (01h)
5	Reserved (00h)	Reserved (00h)	Reserved (00h)
6	Reserved (00h)	Reserved (00h)	Reserved (00h)
7			
8 ... n		Max. message size <ul style="list-style-type: none"> ■ C1 message: 960byte ■ C2 message: 260byte 	When the reserved data ≠ 0, you will get an error response.

4.9.6 Command sequence

The following figure shows the basic flow of commands to communicate with the System SLIO.

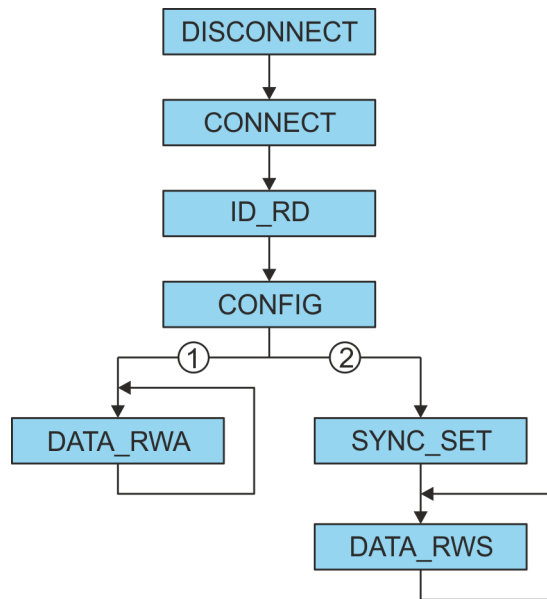

- 1 Asynchronous communication
- 2 Synchronous communication

All of the above commands must be commanded to all stations including extended addresses. The next command must be commanded after confirming the completion of all stations including the extended addresses. ↪ [Chap. 4.9.4 'Command detail' page 73](#)

4.10 Sample application

4.10.1 Overview

Activation of the web server

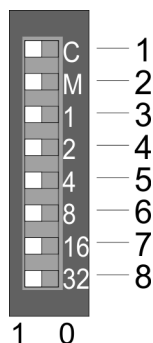

Below, the operation of a system of a IM 053-1ML00 together with a YASKAWA MP3000 series is shown.

1. ➤ To activate the web server at the bus coupler switch off the power supply of the *MECHATROLINK-III* coupler.
2. ➤ Set the *Operating mode 'C'* (position 1) at the address switch to 1: *Maintenance mode*.
3. ➤ At the address switch, set the *MECHATROLINK-III* address as the IP address. For the IP address 192.168.1.1 set the switch '1' (position 3) to 1 and the switches '2' ... '32' (pos. 4 ... 8) to 0. ↪ *Chap. 3.2.3 'Address switch' page 40*
4. ➤ Switch on the power supply of the *MECHATROLINK-III* coupler.
 - ⇒ The coupler is now in maintenance mode. The integrated web server may be accessed via the following IP address:
 - Subnet mask: 255.255.255.0
 - IP address: 192.168.1.1

Setting Parameters

1. ➤ Start your web browser and open the web side of the *MECHATROLINK-III* coupler.
2. ➤ Here you can change default parameters of the modules, if necessary. For this, click at '*Parameter*' of the according module.
3. ➤ To save the configuration, click at the *MECHATROLINK-III* coupler and save the configuration via the dialog '*Configuration*'.
4. ➤ Close you web browser.
5. ➤ PowerOFF and disconnect your *MECHATROLINK-III* coupler

Configuration of the MP3000 series

1. ➤ Define I/O area to SVC definition as multi slave by using the station number with the following parameters:

...	ADR	ExADR	VENDOR	DEVICE	PROFILE	BYTE	...
	03h	00h	***Vendor	Wild Card Device	Standard I/O	16	
	03h	01h	***Vendor	Wild Card Device	Standard I/O	64	

2. ➤ Save the MPE720 project

Starting communication

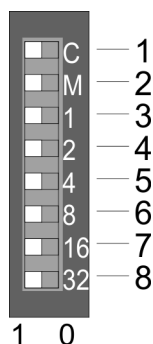

1. ➤ Set the *Operating mode 'C'* (position 1) at the address switch to 0: *Standard mode*.
2. ➤ For the *MECHATROLINK-III* address 03h set switch '1' (position 3) and switch '2' (position 4) to 1. Leave the switches '4' ... '32' (position 5 ... 8) at 0. ↪ *Chap. 3.2.3 'Address switch' page 40*
3. ➤ Connect the *MECHATROLINK-III* coupler with the MP3000 by a *MECHATROLINK-III* cable.
4. ➤ PowerON the *MECHATROLINK-III* coupler and the MP3000.
5. ➤ Transfer the MPE720 project to the MP3000.
6. ➤ Check the connection status and the I/O data transfer.

Supported SVC I/O commands

Code	Command name	Coupler Station	Peripheral Station
0	Data I/O	Yes	Yes
1	Read alarms/warnings	Yes	Yes
2	Clear alarms/warnings	Yes	Yes
3	Read parameters	-	-
4	Write parameters	-	-
5	Read non-volatile parameters	-	-
6	Write non-volatile parameters	-	-
7	Read memory	-	-
8	Write memory	-	-
9 ... 14	Reserved	-	-
15	Communication reset	Yes	Yes
16	Network reset	Yes	Yes

4.10.2 Sequence of coupler commands

4.10.2.1 Read diagnostic data - 16 byte from slot 1

Proceeding

1. **1.** Confirm coupler command = 0 and response command = 0
⇒ Response: 0
2. **2.** Read byte 1 at the same MECHATROLINK-III cycle:
 - Set command data
 - Byte size: Byte 4 ... 5: 8
 - Reserved: Byte 6 .. 7: 0
 - Offset: Byte 8 ... 11: 0x8000 8520
 - Set coupler command 1 (read memory)
 - Set command ID = 0
3. **3.** Wait until response command = 1 (read memory) and command ID = 0
4. **4.** Confirm response data (byte 4 ... 11)
5. **5.** Read byte 2 at the same MECHATROLINK-III cycle:
 - Set command data
 - Byte size: Byte 4 ... 5: 8
 - Reserved: Byte 6 ... 7: 0
 - Offset: Byte 8 ... 11: 0x8000 8528
 - Set coupler command = 1 (read memory)
 - Set command ID = 1
6. **6.** Wait until response command = 1 (read memory) and command ID = 1
7. **7.** Confirm response data (byte 4 ... 11)
8. **8.** NOP at the same MECHATROLINK-III cycle:
 - Set coupler command = 0 (NOP)
 - Set command ID = 0
9. **9.** Wait until response command = 0 (NOP) and command ID = 0

4.10.2.2 Reset diagnostic data - reset slot 1 and slot 2

Proceeding

1. **1.** Confirm coupler command = 0 and response command = 0
2. **2.** For slot 1 at the same MECHATROLINK-III cycle:
 - Set command data
 - Slot number: Byte 4 ... 5: 1
 - Set coupler command = 2 (reset diagnostic data)
 - Set command ID = 0
3. **3.** Wait until response command = 2 (reset diagnostic data) and command ID = 0
4. **4.** Confirm response data (byte 4 ... 5)
5. **5.** For slot 2 at the same MECHATROLINK-III cycle:
 - Set command data
 - Slot number: Byte 4 ... 5: 2
 - Set coupler command = 2 (Reset diagnostic data)
 - Set command ID = 1
6. **6.** Wait until response command = 2 (reset diagnostic data) and command ID = 1
7. **7.** Confirm response data (byte 4 ... 5)

8. → NOP at the same MECHATROLINK-III cycle:
 - Set coupler command = 0 (NOP)
 - Set command ID = 0
9. → Wait until response command = 0 (NOP) and command ID = 1

4.10.3 Communication structure

Standard Operation

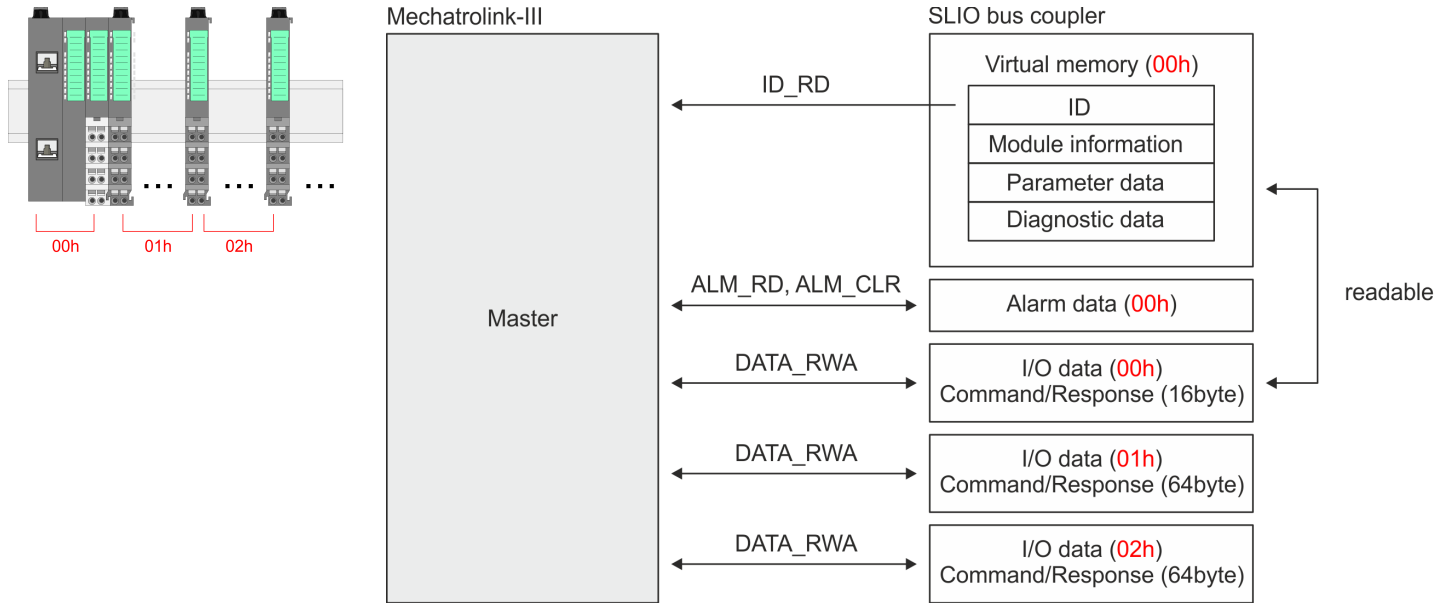

Appendix

Content

A	History of changes.....	93
----------	--------------------------------	-----------

A History of changes

Rev.	Changes
18-42	The manual was new created.