

# System SLIO

SM-S | 02x-1SD10 | Operating manual

HB300 | SM-S | 02x-1SD10 | en | 23-20

Safety Digital I/O - SM-S 02x FSoE



VIPA USA, INC  
980 Birmingham Rd. Ste 721  
Alpharetta, GA 30004 USA

Tel.: +1 (678) 880-6910  
Email: [info@vipausa.com](mailto:info@vipausa.com)  
Internet: [www.vipausa.com](http://www.vipausa.com)

## Table of contents

<b>1</b>	<b>General</b>	<b>5</b>
1.1	Copyright © YASKAWA Europe GmbH	5
1.2	About this manual	6
1.3	Safety information	10
1.4	Safety Information for Users	11
1.5	Intended use	12
1.6	Responsibility of the user	12
1.7	Protective devices	12
1.8	Education of the personnel	13
1.8.1	Qualification	13
1.9	Personal protective equipment	13
1.10	Special hazards	14
1.11	Fire fighting	15
1.12	Electrical safety	15
1.13	Safety facilities	16
1.14	Behavior with dangers and accidents	16
1.15	Sign-posting	16
1.15.1	Signs	16
1.16	Safety hints	17
1.17	Functional safety - safety relevant parameters	17
1.18	Approvals, directives, standards	19
1.19	Use in difficult operating conditions	21
<b>2</b>	<b>Product description</b>	<b>22</b>
2.1	System conception	22
2.1.1	Overview	22
2.1.2	Components	22
2.1.3	Accessories	26
2.1.4	Hardware revision	27
2.2	Dimensions	28
2.3	SDI 4xDC 24V - Operating and display elements	29
2.4	SDI 4xDC 24V - IO structure	35
2.5	SDI 4xDC 24V - FSoE Parameter record set	36
2.5.1	FSoE application parameters	36
2.5.2	FSoE communication parameters	41
2.6	SDI 4xDC 24V - Technical data	42
2.7	SDO 4xDC 24V 0.5A - Operating and display elements	45
2.8	SDO 4xDC 24V 0.5A - IO structure	51
2.9	SDO 4xDC 24V 0.5A - FSoE Parameter record set	52
2.9.1	FSoE application parameters	52
2.9.2	FSoE communication parameters	56
2.10	SDO 4xDC 24V 0.5A - Technical data	57
2.11	Response time	60
2.11.1	Error-free case	60
2.11.2	Existing error	62
2.11.3	Arbitrary run times at single errors	63
2.11.4	Designations	64
2.12	Compatibility list	66

<b>3</b>	<b>Deployment</b>	<b>68</b>
3.1	Planning of a safety-related control system	68
3.2	Industrial security in information technology	70
3.2.1	Protection of hardware and applications	71
3.2.2	Protection of PC-based software	72
3.3	Installation guidelines	72
3.4	Setting the F-address	75
3.4.1	Changing the F-address	76
3.5	Mounting	78
3.5.1	Requirements to the operating personnel	78
3.5.2	Functional principle	79
3.5.3	Mounting Proceeding	79
3.6	Demounting and module exchange	84
3.6.1	Proceeding	84
3.7	Wiring	88
3.7.1	Requirements to the sensor and actuators	93
3.8	Connection examples	96
3.8.1	Connection examples for digital inputs	97
3.8.2	Connection examples for digital safety outputs	101
3.9	Notes for commissioning	107
3.10	Deployment with EtherCAT	108
3.10.1	Basics EtherCAT:	108
3.10.2	General information on deployment	109
3.10.3	Parametrization System SLIO safety module	110
3.10.4	Generate safety program	110
3.10.5	Diagnostic messages EtherCAT	110
3.11	Validation of the system	112
3.12	Operation	113
3.13	Maintenance	113
3.14	Repair	113
3.15	Diagnostics	113
3.15.1	Error response	114
3.15.2	Fault diagnostics	115
3.16	Packing and transport	120
3.17	Storage and disposal	121
3.18	Sample application	122
3.18.1	Precondition	122
3.18.2	Configuration in the safety configuration tool	124
3.18.3	Configuration in the Siemens SIMATIC Manager and SPEED7 EtherCAT Manager	129
3.18.4	Modifications	132
	<b>Appendix</b>	<b>133</b>
A	Checklist planning	135
B	Checklist installation	136
C	Checklist commissioning, parameterization and validation	137
D	Checklist operation	138
E	Checklist modification and retrofitting	139
F	Checklist decommissioning	140

# 1 General

## 1.1 Copyright © YASKAWA Europe GmbH

### All Rights Reserved

This document contains proprietary information of Yaskawa and is not to be disclosed or used except in accordance with applicable agreements.

This material is protected by copyright laws. It may not be reproduced, distributed, or altered in any fashion by any entity (either internal or external to Yaskawa) except in accordance with applicable agreements, contracts or licensing, without the express written consent of Yaskawa and the business management owner of the material.

For permission to reproduce or distribute, please contact: YASKAWA Europe GmbH, European Headquarters, Philipp-Reis-Str. 6, 65795 Hattersheim, Germany

Tel.: +49 6196 569 300

Fax.: +49 6196 569 398

Email: [info@yaskawa.eu](mailto:info@yaskawa.eu)

Internet: [www.yaskawa.eu.com](http://www.yaskawa.eu.com)

### EU / UK Declaration of Conformity

Hereby, YASKAWA Europe GmbH declares that the products and systems are in compliance with the essential requirements and other relevant provisions. Conformity is indicated by the CE and UKCA marking affixed to the product.

### Conformity Information

For more information regarding CE and UKCA marking and Declaration of Conformity (DoC), please contact your local representative of YASKAWA Europe GmbH.

### EU Machinery Directive / UK Supply of Machinery (Safety) Regulation

The System SLIO safety modules of this manual meet all the requirements of the machinery directive 2006/42/EG and Supply of Machinery (Safety) Regulation 2008 Nr. 1597.

### Certification

The product SLIO safety signal module was developed and certified according to the standards specified at "Approvals, directives, standards" in chapter "Safety".

It is suited for use in applications up to category 4 / PL e of EN ISO 13849-1 and SIL 3 of EN 62061 and IEC 61508.

Test report number: 968/M 387.07/20

Certificate number: 01/205/5301/20

### Trademarks

SPEED7 and SLIO are registered trademarks of YASKAWA Europe GmbH.

SIMATIC and TIA Portal are registered trademarks of Siemens AG.

EtherCAT® is a registered trademark and patented technology, licensed by Beckhoff Automation GmbH.

All other trademarks, logos and service or product marks specified herein are owned by their respective companies.

**General terms of use**

Every effort has been made to ensure that the information contained in this document was complete and accurate at the time of publishing. We cannot guarantee that the information is free of errors, and we reserve the right to change the information at any time. There is no obligation to inform the customer about any changes. The customer is requested to actively keep his documents up to date. The customer is always responsible for the deployment of the products with the associated documentation, taking into account the applicable directives and standards.

This documentation describes all hardware and software units and functions known today. It is possible that units are described that do not exist at the customer. The exact scope of delivery is described in the respective purchase contract.

**Document support**

Contact your local representative of YASKAWA Europe GmbH if you have errors or questions regarding the content of this document. If such a location is not available, you can reach YASKAWA Europe GmbH via the following contact:

Email: Documentation.HER@yaskawa.eu

**Technical support**

Contact your local representative of YASKAWA Europe GmbH if you encounter problems or have questions regarding the product. If such a location is not available, you can reach the Yaskawa customer service via the following contact:

YASKAWA Europe GmbH,  
European Headquarters, Philipp-Reis-Str. 6, 65795 Hattersheim, Germany  
Tel.: +49 6196 569 500 (hotline)  
Email: support@yaskawa.eu

## 1.2 About this manual

**Objective and contents**

This manual is the translation of the original instructions!

This manual describes the System SLIO safety signal modules for EtherCAT.

- It describes the structure, project engineering and deployment.
- The manual is written for users with basic knowledge of automation technology and profound knowledge of IO-Link communication.
- The manual consists of chapters. Each chapter describes a completed topic.
- The following guides are available in the manual:
  - An overall table of contents at the beginning of the manual.
  - References with pages numbers.

Product	Order number	as of version:
SDI 4xDC 24V	021-1SD10	HW: 2
SDO 4xDC 24V 0.5A	022-1SD10	HW: 2

**Icons Headings**

Important passages in the text are highlighted by following icons and headings:

**DANGER!**

Immediate danger to life and limb of personnel and others.  
Non-compliance will cause death or serious injury.

**WARNING!**

Hazardous situation to life and limb of personnel and others.  
Non-compliance may cause death or serious injury.

**CAUTION!**

Hazardous situation to life and limb of personnel and others. Non-compliance may cause slight injuries.  
This symbol is also used as warning of damages to property.

**NOTICE!**

Designates a possibly harmful situation. Non-compliance can damage the product or something in its environment.



*Supplementary information and useful tips.*

## Liability Limitation

All data and notes in these instructions were prepared with consideration to the statutory standards and regulations, the present state of technology, as well as our many years of knowledge and experience.

The manufacturer accepts no liability for damage caused because:

- Non-compliance with the instructions
- Non-specified use
- Use of untrained personnel

The actual scope of delivery can, by special designs, deviate from the explanations and presentations given here, because of the utilization of additional order options, or because of the most recent technical changes.

The user is responsible for the execution of service and commissioning according to the safety instructions of the prevailing standards and other relevant national and local instructions concerning conductor dimensioning and protection, earthing, disconnector, overcurrent protection and so on.

For damages, which result from the mounting or from the connection, the one is liable, who has carried out the mounting or the installation.

We have checked the contents of this manual for agreement with the hardware and software described. Since deviations cannot be precluded entirely, we cannot guarantee full agreement. However, the data in this manual are reviewed regularly. Necessary corrections are included in subsequent editions.

Suggestions for improvement are welcomed.

For damage, which results from missing or insufficient knowledge of the manual, any liability of the manufacturer is impossible.

Therefore, the operator is recommended to have the instruction of the persons concerned confirmed in writing.

Modifications or functional alternations on the product are not allowed due to safety reasons. Any modification on the product not explicitly authorized by the manufacturer will result in loss of any liability claims to the vendor. The same applies if non authorized parts or equipment are used.

## Copyright

This manual is to be treated confidentially. It has been provided only for the personnel, which use the product. The transfer of this document to third parties without the authorization in writing of the vendor is prohibited.



*The contents, texts, drawings, pictures and any other illustrations are copyrighted and subject to other protection rights. Any person unlawfully using this publication is liable to criminal prosecution.*



<b>Use of this manual</b>	<p>This safety manual contains information for the intended use of the System SLIO safety signal modules.</p> <p>Knowledge of regulations and the proper technical implementation of the safety instructions detailed in this manual performed by qualified personnel are prerequisites for safely planning, engineering, programming, installing and starting up the System SLIO safety modules as well as for ensuring safety during their operation and maintenance. ↪ <i>Chap. 1.8 'Education of the personnel' page 13</i></p> <p>Yaskawa will not be held liable for severe personal injuries, damage to property or the surroundings caused by any of the following: unqualified personnel working on or with the devices, de-activation or bypassing of safety functions, or failure to comply with the instructions detailed in this manual.</p> <p>The safety components and systems have been developed, manufactured and tested in compliance with the pertinent safety standards and regulations. They may only be used for the intended applications under the specified environmental conditions.</p> <p>They must be used only as specified in environmental descriptions and be connected only to approved external devices.</p> <p>The manual contains safety instructions, description of the modules and information about life cycle.</p>
<b>Applicable documentation</b>	<p>In the safety signal module components of other manufacturers are possibly integrated. For these purchased parts of the respective manufacturers risk evaluations were carried out. The conformity of the constructions to the valid European and national regulations was declared by the according manufacturer.</p>
<b>Warranty conditions</b>	<p>The warranty conditions can be found in the "General terms and conditions" at <a href="http://www.yaskawa.eu.com">www.yaskawa.eu.com</a>.</p>

### 1.3 Safety information

#### Applications conforming with specifications

The System SLIO is constructed and produced for:

- communication and process control
- general control and automation applications
- industrial applications
- operation within the environmental conditions specified in the technical data
- installation into a cubicle with degree of protection IP54 or better

The modules have been engineered and designed exclusively for the intended use described in this documentation.

The modules are intended used if you consider all references and information of this manual.

**WARNING!****Danger by non intended use!**

Every application in excess of the intended use and/or other use of the product, can lead to hazardous situations.

**DANGER!**

This device is not certified for applications in

- in explosive environments (EX-zone)

To prevent hazards and ensure optimum performance, no changes, modifications or conversions may be made to the product that have not been expressly approved by the manufacturer.

#### Documentation

Every person working with the product must have read and understood the operating instructions before carrying out any work.

The manual must be available to all personnel in the

- project design department
- installation department
- commissioning
- operation

**CAUTION!****The following conditions must be met before using or commissioning the components described in this manual:**

- Hardware modifications to the process control system should only be carried out when the system has been disconnected from power!
- Installation and hardware modifications only by properly trained personnel.
- The national rules and regulations of the respective country must be satisfied (installation, safety, EMC ...)

**DANGER!**

To prevent hazards and ensure optimum performance, no changes, modifications or conversions may be made to the product that have not been expressly approved by the manufacturer.

**Maintenance** If you keep the prescribed environmental conditions (see technical data) the corresponding safety module is maintenance-free.

**Spare parts** Please only use original spare parts of Yaskawa.



**WARNING!**

Incorrect or faulty spare parts can cause damage, malfunction or failure as well as affect security.

**Shipping** For shipping always use the original packaging.

**Disposal** **National rules and regulations apply to the disposal of the unit!**

## 1.4 Safety Information for Users

### Handling of electrostatic sensitive modules

The modules make use of highly integrated components in MOS-Technology. These components are extremely sensitive to over-voltages that can occur during electrostatic discharges. The following symbol is attached to modules that can be destroyed by electrostatic discharges.



The Symbol is located on the module, the module rack or on packing material and it indicates the presence of electrostatic sensitive equipment. It is possible that electrostatic sensitive equipment is destroyed by energies and voltages that are far less than the human threshold of perception. These voltages can occur where persons do not discharge themselves before handling electrostatic sensitive modules and they can damage components thereby, causing the module to become inoperable or unusable. Modules that have been damaged by electrostatic discharges can fail after a temperature change, mechanical shock or changes in the electrical load. Only the consequent implementation of protection devices and meticulous attention to the applicable rules and regulations for handling the respective equipment can prevent failures of electrostatic sensitive modules.

### Measurements and alterations on electrostatic sensitive modules

When you are conducting measurements on electrostatic sensitive modules you should take the following precautions:

- Floating instruments must be discharged before use.
- Instruments must be grounded.



**CAUTION!**

Personnel and instruments should be grounded when working on electrostatic sensitive modules.

## 1.5 Intended use

### General

The product is exclusively designed and constructed for the intended use described in this manual. The product is intended used if all the notes and information of this manual are considered.



#### **WARNING!**

#### **Danger by not intended use!**

Each use of the product, which differs to the intended use can lead to dangerous situations.

Therefore

- Use the product only intended.
- Use the product only together with the recommended components.
- Consider all the data in this manual.
- Ensure that only qualified personnel work with/at the product. ↪ *Chap. 1.8 'Education of the personnel' page 13*
- Ensure during configuration that the product is operated within its specifications.
- Ensure that the power supply corresponds to the given specifications.
- Only use the product in a technically perfect condition.
- Only use the product in combination with approved components.
- Only use the product in an area of second type (industrial area). The product was developed such as this fulfils the requirements of the category C3. For operation an approved power supply (SELV/PELV) is necessary. Here With the usage of the product in an area of first type, category C2/C1 (living-, business and trade without an interstage transformer directly at a public low-voltage-system) the cabinet builder has to reduce the emission (conducted and radiated) by special measure steps, which are to be demonstrated, since it can come without any additional measures to EMC disturbances. Whether a products described here reaches category C2/C1 with additional measures, cannot be ensured.

### Changes and modifications at the product

To avoid endangerments and to ensure the optimal power neither changes nor modifications may be made at the product, which are not specially approved by the manufacturer.

## 1.6 Responsibility of the user

### General

The product is used in the commercial range. The user of the product is subject of the statutory duties to work safety. In addition to the safety instructions in this manual, for the usage environment of the product valid safety, accident prevention and environmental protection regulations must be adhered.

- The user must be informed about the valid industrial safety regulations and determine in an endangerment evaluation additionally dangers, which arise as a result of the special conditions for the product on the place of operation. This is to be transcribed with working instructions for the operation of the product.
- These working instructions must be kept in direct environment of the product and accessible at any time for people, which work with the product.
- The working instructions must fully be adhered.
- The product is only to be operated in a technically flawless condition.

## 1.7 Protective devices

### Protection

The place of installation of the safe field bus modules must comply for devices according to IP20.

## 1.8 Education of the personnel



### WARNING!

#### Risk of injury resulting from insufficient qualification!

Improper use can cause considerable personal injury and material damage.

Therefore: The special activities may only be executed by personnel nominated by the respective chapters.

### 1.8.1 Qualification

In the manual the following qualifications for different activities are defined:

#### Operating personnel

The automation system may only be operated by persons, which are trained, instructed and authorized. Troubleshooting, maintenance, cleaning, maintenance and replacement must be performed only by skilled or trained personnel. These persons have to know the instruction manual and have to act accordingly. Commissioning and training should only be performed by qualified personnel.

#### Qualified personnel

These are electrical engineers and electricians of the customer or third party, which are authorized by the manufacturer and which have learned installation and commissioning by the manufacturer and are allowed to ground, mark and install electrical circuits and devices in accordance to the standard safety technology. Qualified personnel is trained and instructed according to the corresponding valid standards in safety technology in the care and use of appropriate safety equipment.

## 1.9 Personal protective equipment

### General

During work, the wearing of personal protective equipment is needed to minimize health hazards.

- Always wear the necessary protective equipment for the corresponding job.
- For your own safety regard the signs, which are in your work space.

#### Work clothing



is close-fitting clothing with low tensile strength, with tight sleeves and without a protruding part. Depending on the application it should be prevented, that the carrier gets serious injured or is exposed to health risk during work. For reasons of injury no jewellery like rings and chains should be worn.

#### Protective helmet



for protection against falling and flying objects.

## Special hazards

**Safety shoes**

for protection against falling heavy objects.

**Protective gloves**

to protect hands from friction abrasions, punctures or injuries, as well as from contact with hot objects.

**Wear at special works:  
Eye protector**

to protect eyes from flying parts and liquid splashes.

**1.10 Special hazards****General**

In the following section the residual risks are listed. Regard the listed safety warnings here and the notes in the whole manual to reduce health hazards and to avoid dangerous situations.

**Electric current****DANGER!****Risk of death by electric current!**

Contact with live parts is immediate danger to life. Damage of the insulation or of components can be danger to life.

Therefore: Immediately turn off the power supply when the insulation is damaged. Work on the electrical system only by qualified personnel. Always power-off and secure the electrical system during the work on it.

**Risk by residual energy****DANGER!****Risk of death by electric current!**

After disconnecting the device from main voltage, parts such as power connections should only be touched when the capacitors are discharged in the device.

Therefore: Regard discharge time of the capacitors, do not touch live parts before. Regard corresponding instructions on the device. If you have connected additional capacitors on the link, the discharge of the link can last considerably longer. In this case you have to determine the required waiting period or even to measure whether the device is free of voltage.

## Moved objects

**WARNING!****Risk of injury from moving parts!**

Rotary respectively linear moved parts can cause serious injuries.

Therefore: Do not touch moving parts during operation. Do not open the cover during operation. The mechanical residual energy depends on the application. Driven components rotate respectively move for a certain time even after switching off the power supply. Here serve for suited safety devices.

## 1.11 Fire fighting

**DANGER!****Risk of death by electric current!**

Risk of an electrical shock when using a conducting fire fighting medium.



Therefore use the following fire fighting medium:

ABC powder / CO<sub>2</sub>

## 1.12 Electrical safety

### General

The System SLIO Safety is designed according to IEC61131-2 for degree of pollution 2. This means only non-conductive pollution may occur during operation. Temporary conductivity by condensation is only allowed when the module is out of operation.

**WARNING!****Risk of injury from conductive pollution!**

During the operation there is no conductive pollution allowed.

Therefore: Before the system is installed check and guarantee if necessary by additional measures that the degree of pollution 2 is not exceeded (e.g. installation in a cubicle with degree of protection IP54 or better).

### Note to the power supply

**WARNING!****Risk of injury by electric current!**

There may only devices be connected to the module, which have a safe separation of the 230V power. The power supply to generate 24V power must correspond to the requirements for PELV/SELV according to EN 50178.

## 1.13 Safety facilities

**WARNING!****Risk of death by non-functioning safety facilities!**

Safety facilities serve for maximum safety during operation. Even if by safety facilities working process become complicated, its never allowed to circumvent them. The security is guaranteed only when the safety facilities are intact.

Therefore: Before beginning the work check whether the safety facilities are installed properly and functional.

## 1.14 Behavior with dangers and accidents

**Preventive measures**

- Always be prepared for accidents or fire!
- First-aid equipment (first aid kit, blankets etc.) and keep fire extinguisher handy.
- Make Personal with accident message, first-aid and rescue mechanisms familiar.

**In case of emergency: act correctly**

- Set immediately the device with emergency stop out of operation.
- Initiate first-aid measures.
- Rescue persons from the danger zone.
- Inform responsible on-site.
- Alarm medical and / or fire department.
- Make free the access routes for emergency vehicles.

## 1.15 Sign-posting

**WARNING!****Danger of injury by illegible symbols**

In course of time stickers and symbols on the equipment can get dirty or otherwise become unrecognizable.

Therefore: Please hold all the safety warnings and operation instructions on the device in always well readable condition.

### 1.15.1 Signs

The following symbols and signs are in the work space. They refer to the direct environment in which they are attached.



**Electrical voltage**

In the such marked work space only qualified personnel may work. Unauthorized may not touch the marked equipment.

**DANGER!****Danger of life by electrical power!**

Time for discharge > 1 Minute

Stored electrical charge

Therefore: Consider discharge time of capacitor and do not touch live parts before. Consider appropriate instructions on the device. If you have connected additional capacitors at DC, the discharge of the DC link can last longer. In this case you have to determine respectively to measure the required waiting time whether the device is free of voltage.

**1.16 Safety hints**

The modules of the System SLIO represent the current state of the art and fulfill the valid safety regulations and the appropriate harmonized, European standards (EN)

For the user additionally is valid the:

- relevant rules for the prevention of accidents
- EG directives or other country-specific regulations
- generally accepted safety rules
- general ESD regulations

Disturbances of any kind or other damage must be reported to a responsible person. Protective and safety equipment must not be circumvented or bypassed. Dismounted protective equipment must be mounted and functionally tested before a restart. The modules are to be secured against misuse or accidental use. Original mounted signs, labels, stickers are to be always considered and be held in a readable condition.

**1.17 Functional safety - safety relevant parameters****General**

This chapter describes characteristics associated to functional safety. In according to IEC 61508 safety means that the residual error probability of the whole system below the standard limits. In accordance to the whole system internal safety-relevant device errors must be detected and be led to a safe condition.

**Safety relevant parameters**

The values here refer to the modules of this manual. Safety relevant characteristics may always be found in the according manuals of the modules.

Functional safety - safety relevant parameters

**Characteristics SDI 4xDC  
24V**

Characteristics according to IEC 61508	Meaning
$PFH_D = 0.25 * 10^{-9}/h$	<b>Probability of failure per Hour:</b> Probability of danger failure per hour.
$PFD_{avg} = 2.14 * 10^{-5}$	<b>Probability of Failure on Demand average:</b> Average of probability of failure on demand.
SFF according SIL 3	<b>Safe Failure Fraction:</b> Fraction of failure, which lead to a safe state.

Characteristics according to DIN EN ISO 13849-1	Meaning
$MTTF_D$ : high (339 years)	<b>Mean Time To dangerous Failure</b>
DCavg: high	<b>Diagnostic Coverage average</b>
Device life: 20 years	During the expected life of the device of up to 20 years, no proof test is required. After this interval, the System SLIO safety module must be decommissioned and sent back to the vendor.

**Characteristics SDO 4xDC  
24V, 0.5A**

Characteristics according to IEC 61508	Meaning
$PFH_D = 0.22 * 10^{-9}/h$	<b>Probability of failure per Hour:</b> Probability of danger failure per hour.
$PFD_{avg} = 1.85 * 10^{-5}$	<b>Probability of Failure on Demand average:</b> Average of probability of failure on demand.
SFF according SIL 3	<b>Safe Failure Fraction:</b> Fraction of failure, which lead to a safe state.

Characteristics according to DIN EN ISO 13849-1	Meaning
$MTTF_D$ : high (192 years)	<b>Mean Time To dangerous Failure:</b>
DCavg: high	<b>Diagnostic Coverage average:</b>
Device life: 20 years	During the expected life of the device of up to 20 years, no proof test is required. After this interval, the System SLIO safety module must be decommissioned and sent back to the vendor.

**CAUTION!**

If the user calculates his safety application with the specified data for e.g. 10 years, the safety controller is to be decommissioned and sent back to the vendor at the end of its lifetime. A proof test cannot be established by the user.

## 1.18 Approvals, directives, standards

### Conformity and approval

Conformity		
CE	2014/30/EU	EMC Directive
	2006/42/EG	Machinery Directive
RoHS (EU)	2011/65/EU	Restriction of the use of certain hazardous substances
UKCA	2016 No. 1091	Electromagnetic Compatibility Regulations
	2008 No. 1597	Supply of Machinery (Safety) Regulation
RoHS (UK)	2012 No. 3032	Use of Certain Hazardous Substances

### Protection of persons and device protection

Type of protection	-	IP20
Electrical isolation		
to the field bus	-	electrically isolated
to the process level	-	electrically isolated
Insulation resistance	EN 61131-2	-
Insulation voltage to reference earth		
Inputs / outputs	-	AC / DC 50V, test voltage AC 500V
Protective measures	-	against short circuit

### Environmental conditions to EN 61131-2

Climatic		
Storage / transport	EN 60068-2-14	-25...+70°C
Operation		
Horizontal installation hanging	EN 61131-2	0...+60°C
Horizontal installation lying	EN 61131-2	0...+55°C
Vertical installation	EN 61131-2	0...+50°C
Air humidity	EN 60068-2-30	RH1 (without condensation, rel. humidity 10...95%)
Pollution	EN 61131-2	Degree of pollution 2
Installation altitude max.	-	2000m
Mechanical		
Oscillation	EN 60068-2-6	1g, 9Hz ... 150Hz
Shock	EN 60068-2-27	15g, 11ms

Approvals, directives, standards

**Mounting conditions**

Mounting place	-	In the control cabinet (IP54 or better)
Mounting position	-	Horizontal hanging ↪ 'Possibilities' page 80

EMC	Standard	Comment
Emitted interference	EN 61000-6-4	Class A (Industrial area)
Noise immunity zone B	EN 61000-6-2	Industrial area
		EN 61000-4-2
	EN 61000-4-3	HF field immunity (casing) 80MHz ... 1000MHz, 10V/m, 80% AM (1kHz) 1.4GHz ... 2.0GHz, 3V/m, 80% AM (1kHz) 2GHz ... 2.7GHz, 1V/m, 80% AM (1kHz)
	EN 61000-4-6	HF conducted 150kHz ... 80MHz, 10V, 80% AM (1kHz)
	EN 61000-4-4	Burst, degree of severity 3
	EN 61000-4-5	Surge, degree of severity 3 <sup>1</sup>

1) Due to the high-energetic single pulses with Surge an appropriate external protective circuit with lightning protection elements like conductors for lightning and over-voltage is necessary.

**Example of lightning protection conductors**

Application	Vendor	Article	Description
Feed	Dehn	BLITZDUCTOR VT BVT AVD 24	External Lightning protection (DC24V/10A)
Digital inputs, test pulse outputs	Dehn	DEHNconnect RK DCO RK ME 24	External Lightning protection (DC24V/0.5A)
Digital outputs	Dehn	DEHNconnect RK DCO RK D 5 24	External Lightning protection (DC24V/10A)
EtherCAT interface	Dehn	DEHNpatch DPA M CLE RJ45B 48	External Lightning protection (RJ45/48V)

**Norms and standards**

DIN EN 61508 part 1-7	Functional safety of electrical/electronic/programmable electronic safety-related systems
DIN EN ISO 13849-1	Safety of machinery: Safety-related parts of control systems
DIN EN 61784-3	Functional safety field buses - General rules and profile definitions
DIN EN 60204-1	Electrical equipment of machines

**Norms and standards**

DIN EN 61131-2	Programmable logic controllers, part 2: Equipment requirements and tests
DIN EN 61000-4-11	Mains voltage variation
Row SN 29500	Failure rate, component, expected value, reliability
DIN EN 61496-1	Electro sensitive protective equipment

**Requirements to clearance / creep-age current distances and system power supply**

DIN EN 61131-2	The definition of clearance and creep-age current distances takes place in accordance to EN 61131-2. For the safe field bus coupler over-voltage category 2 and degree of pollution 2 are basis.
DIN EN 13849	The acceptance of error exclusions for short-circuits between neighbouring conductor or for short-circuits between neighbouring components must be avoided as far as possible by suitable circuit and layout measures. If an error exclusion is inevitable, measures are to be used in accordance with EN 13849 part of 2.
DIN EN 50178	The device is developed for operation on 24V power supplies, which correspond to the PELV-/SELV regulations in accordance to EN 50178.
DIN EN 61508	The normative requirements of the 61508 (increased EMC requirements and requirements concerning isolation) are to be fulfilled also for the common voltage circuit of the SLIO system.
DIN EN 50178	So that the electrical values for extra-low voltage with safe separation cannot be exceeded on the safe field bus coupler, for the system 24V power supplies are exclusively used, which correspond to the PELV /SELV regulations in accordance with EN 50178.
	In order to protect the safe field bus couplers against over-voltage, a suitable over-voltage protection is provided.
DIN EN 60204-1	The 24V power supply must keep the voltage interrupt according to EN 60204-1.

**Requirements for environmental and EMC testing**

DIN EN 61131-2	Programmable logic controllers, part 2: Equipment requirements and tests
DIN EN 62061 Appendix E	For the EMC immunity tests, the increased requirements according to appendix E of EN 62061 are applied.

**1.19 Use in difficult operating conditions**

*Without additional protective measures, the products must not be used in locations with difficult operating conditions; e.g. due to:*

- *dust generation*
- *chemically active substances (corrosive vapors or gases)*
- *strong electric or magnetic fields*

## 2 Product description

### 2.1 System conception

#### 2.1.1 Overview

System SLIO is a modular automation system for assembly on a 35mm mounting rail. By means of the peripheral modules with 2, 4 or 8 channels this system may properly be adapted matching to your automation tasks. The wiring complexity is low, because the supply of the DC 24V power section is integrated to the backplane bus and defective modules may be replaced with standing wiring. By deployment of the power modules in contrasting colors within the system, further isolated areas may be defined for the DC 24V power section supply, respectively the electronic power supply may be extended with 2A.

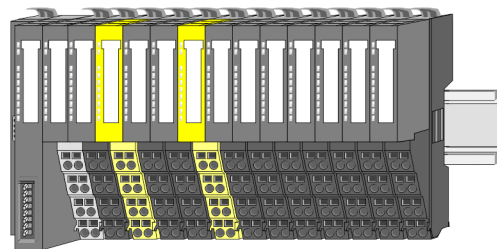
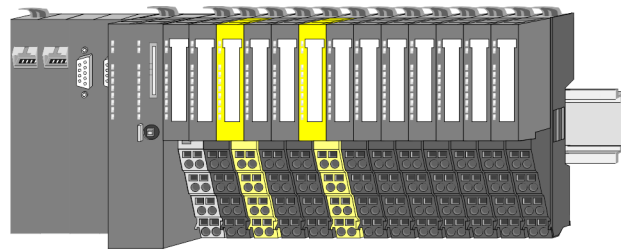

#### 2.1.2 Components

##### Components

- CPU (head module)
- Bus coupler (head module)
- 8x periphery modules
- 16x periphery modules
- Power modules
- Accessories

##### CPU 01x



With this CPU 01x, CPU electronic and power supply are integrated to one casing. As head module, via the integrated power module for power supply, CPU electronic and the electronic of the connected periphery modules are supplied. The DC 24 power section supply for the linked periphery modules is established via a further connection of the power module. By installing of up to 64 periphery modules at the backplane bus, these are electrically connected, this means these are assigned to the backplane bus, the electronic modules are power supplied and each periphery module is connected to the DC 24V power section supply.

## Bus coupler

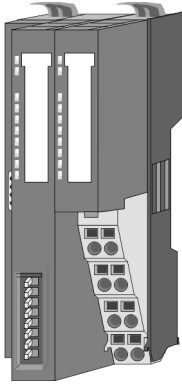

With a bus coupler bus interface and power module is integrated to one casing. With the bus interface you get access to a subordinated bus system. Via the integrated power module for power supply the bus interface is supplied as well as the electronic of the connected periphery modules. The DC 24 power section supply for the linked periphery modules is established via a further connection. By installing of up to 64 periphery modules at the bus coupler, these are electrically connected, this means these are assigned to the backplane bus, the electronic modules are power supplied and each periphery module is connected to the DC 24V power section supply.



### CAUTION!

Bus interface and power module may not be separated!  
Here you may only exchange the electronic module!

## Bus coupler for System SLIO safety modules

The System SLIO safety modules of this manual can be used with the following bus coupler:

- 053-1EC01 - EtherCAT: Firmware V2.0.0 and up and ESI file V005 and up



*The IM 053-1EC01 must be in Enhanced mode to operate the FSoE modules. More information on setting the operating modes can be found in the IM 053-1EC01 manual.*

## Configuration of the System SLIO safety modules

- The programming of the safety program and the parametrization of the safety modules are carried out in the configuration tool of the FSoE master.
- The configuration of the EtherCAT system with the System SLIO I/O modules takes place in the *SPEED7 EtherCAT Manager*.
- The safety configuration is transferred to the *SPEED7 EtherCAT Manager* via an ESI file, which must be generated in the configuration tool of the FSoE master.

## Periphery modules

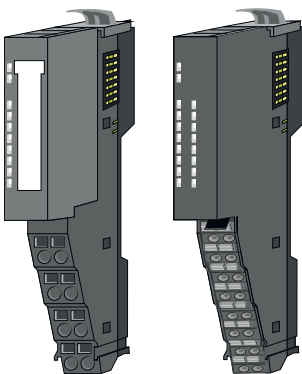

The periphery modules are available in the following 2 versions, whereby of each the electronic part can be replaced with standing wiring:

- 8x periphery module for a maximum of 8 channels.
- 16x periphery module for a maximum of 16 channels.

**8x periphery modules**

Each 8x periphery module consists of a *terminal* and an *electronic module*.

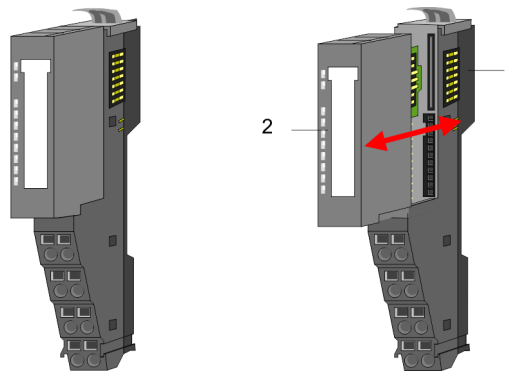

- 1 Terminal module
- 2 Electronic module

**Terminal module**

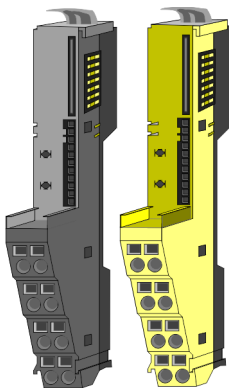

The *terminal* module serves to carry the electronic module, contains the backplane bus with power supply for the electronic, the DC 24V power section supply and the staircase-shaped terminal for wiring. Additionally the terminal module has a locking system for fixing at a mounting rail. By means of this locking system your System SLIO may be assembled outside of your switchgear cabinet to be later mounted there as whole system.

**Electronic module**

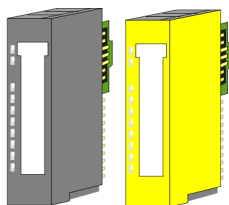

The functionality of a System SLIO periphery module is defined by the *electronic* module, which is mounted to the terminal module by a sliding mechanism. With an error the defective module may be exchanged for a functional module with standing installation. At the front side there are LEDs for status indication. For simple wiring each module shows a corresponding connection diagram at the front and at the side.

**Safety periphery modules**

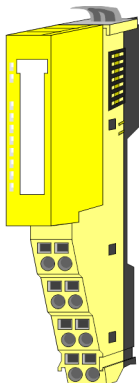

According to structure and dimensions the *safety periphery modules* correspond to the standard periphery modules of the System SLIO. For better recognition the color of the safety modules is yellow. Please consider that the safety electronic module may only be used at an yellow terminal module! The operation with mechanical compatible terminal modules is not allowed.

**16x periphery modules**

Each 16x periphery module consists of an *electronic unit* and a *terminal block*.



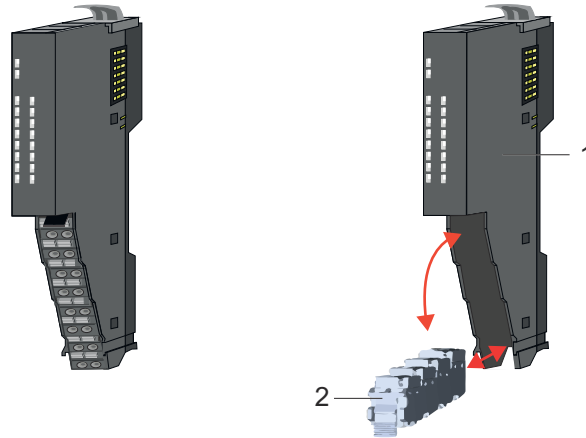

- 1 Electronic unit
- 2 Terminal block

### Electronic unit

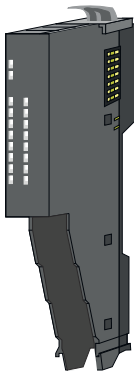

The functionality of a 16x periphery module is defined via the terminal block, which is connected to the *electronic unit* via a secure flap mechanism. In the case of an error you can exchange the defective electronic unit for a functional unit with standing wiring. At the front side there are LEDs for status indication. For easy wiring each electronic unit shows corresponding connection information at the side. The electronic unit provides the slot for the terminal block for the wiring and contains the backplane bus with power supply for the electronic and the connection to the DC 24V power section supply. Additionally the electronic unit has a locking system for fixing it at a mounting rail. By means of this locking system your system may be assembled outside of your switchgear cabinet to be later mounted there as whole system.

### Terminal block



The *terminal block* provides the electrical interface for the signalling and supplies lines of the module. When mounting the terminal block, it is attached to the bottom of the electronic unit and turned towards the electronic unit until it clicks into place. With the wiring a "push-in" spring-clip technique is used. This allows a quick and easy connection of your signal and supply lines. The clamping off takes place by means of a screwdriver.

### Power module

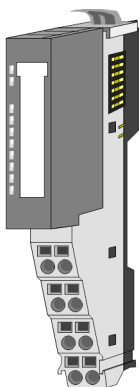

In the System SLIO the power supply is established by power modules. These are either integrated to the head module or may be installed between the periphery modules. Depending on the power module isolated areas of the DC 24V power section supply may be defined respectively the electronic power supply may be extended with 2A. For better recognition the colour of the power modules are contrasting to the periphery modules.

**Clamp modules**

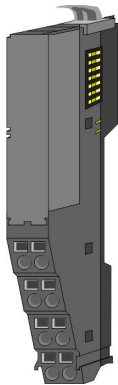

A *clamp module* is a distributor module. According to the module GND respectively DC 24V of the power section supply may be accessed by the clamp connectors. The back-plane bus is looped through the module. So this module has no module ID, but influences the maximum number of modules to be connected.

**2.1.3 Accessories**

**Shield bus carrier**



*Please note that a shield bus carrier cannot be mounted on a 16x periphery module!*

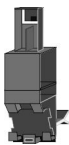

The shield bus carrier (order no.: 000-0AB00) serves to carry the shield bus (10mm x 3mm) to connect cable shields. Shield bus carriers, shield bus and shield fixings are not in the scope of delivery. They are only available as accessories. The shield bus carrier is mounted underneath the terminal of the terminal module. With a flat mounting rail for adaptation to a flat mounting rail you may remove the spacer of the shield bus carrier.

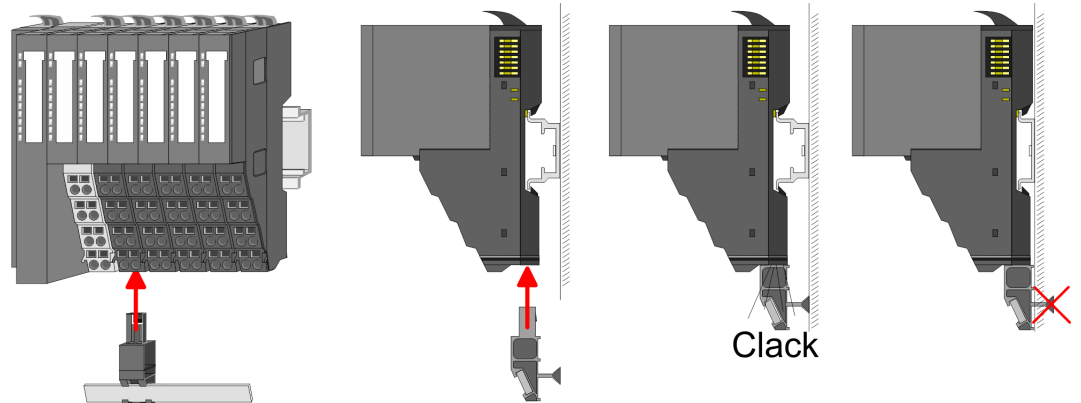

**Bus cover**

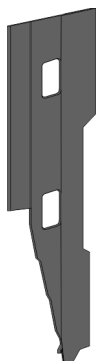

With each head module, to protect the backplane bus connectors, there is a mounted bus cover in the scope of delivery. You have to remove the bus cover of the head module before mounting a System SLIO module. For the protection of the backplane bus connector you always have to mount the bus cover at the last module of your system again. The bus cover has the order no. 000-0AA00.

## Coding pins



*Please note that a coding pin cannot be installed on a 16x periphery module! Here you have to make sure that the associated terminal block is plugged again when the electronics unit is replaced.*

There is the possibility to fix the assignment of electronic and terminal module. Here coding pins (order number 000-0AC00) can be used. The coding pin consists of a coding jack and a coding plug. By combining electronic and terminal module with coding pin, the coding jack remains in the electronic module and the coding plug in the terminal module. This ensures that after replacing the electronic module just another electronic module can be plugged with the same encoding.

### 2.1.4 Hardware revision

#### Hardware revision on the front

- The hardware revision is printed on every System SLIO module.
- Since a System SLIO 8x periphery module consists of a terminal and electronic module, you will find a hardware revision printed on each of them.
- Authoritative for the hardware revision of a System SLIO module is the hardware revision of the electronic module. This is located under the labeling strip of the corresponding electronic module.
- Depending on the module type, there are the following 2 variants e.g. to indicate hardware revision 1:
  - Current modules have a 1 on the front.
  - With earlier modules, the 1 is marked with 'X' on a number grid.

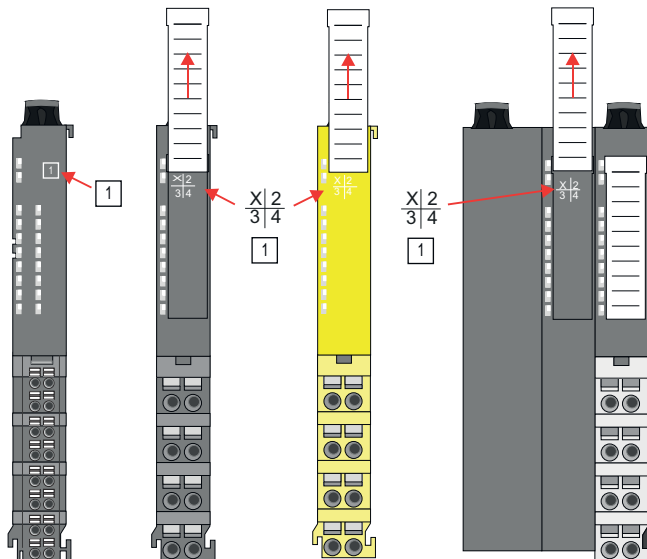

## 2.2 Dimensions

### Dimensions bus coupler

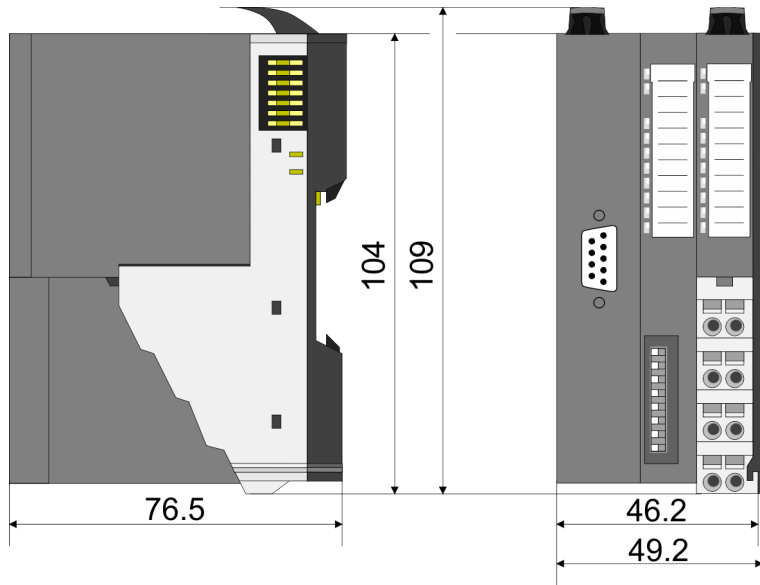

### Dimensions periphery module (here Safety)

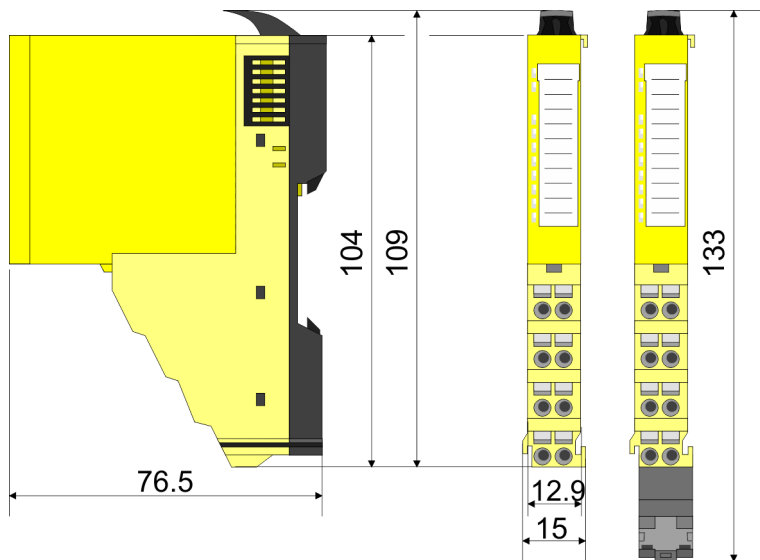

### Dimensions electronic module (here Safety)

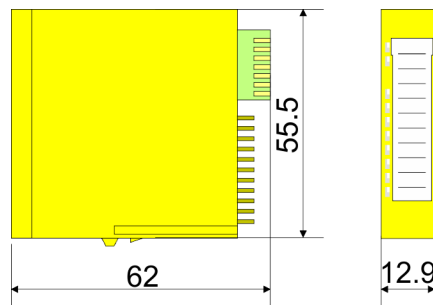

Dimensions in mm

The dimensions of the System SLIO safety modules are identical to those of the System SLIO standard modules.

## 2.3 SDI 4xDC 24V - Operating and display elements

### Description

The electronic module collects the binary control signals from the process level and transmits them isolated to the central bus system. It has 4 channels and their status is monitored via LEDs.

### Properties

- 4 digital Inputs isolated to the backplane bus
- Status indication of the channels via LEDs
- Safety module with automatic disconnection in case of error according to IEC 61508 SIL3 and EN ISO 13849-1, Cat.4 / PL e

### Structure

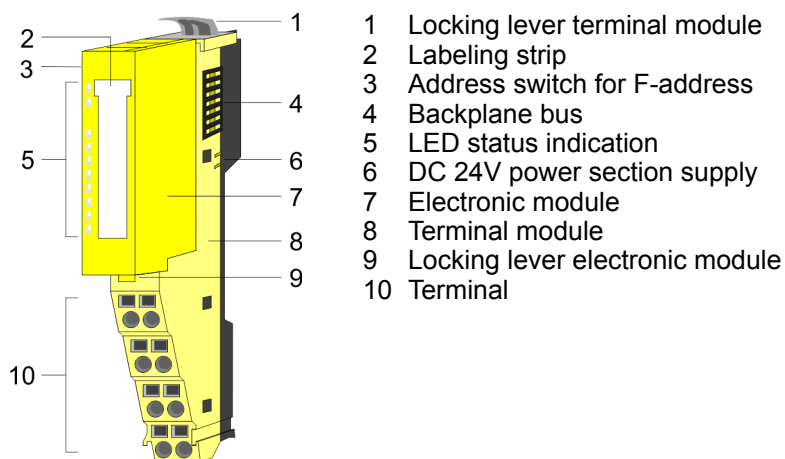

- 1 Locking lever terminal module
- 2 Labeling strip
- 3 Address switch for F-address
- 4 Backplane bus
- 5 LED status indication
- 6 DC 24V power section supply
- 7 Electronic module
- 8 Terminal module
- 9 Locking lever electronic module
- 10 Terminal

Status indication

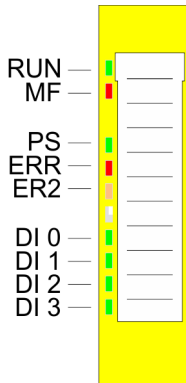

RUN green	MF red	Description
<input checked="" type="checkbox"/>	<input type="checkbox"/>	Bus communication is OK Module status is OK
<input checked="" type="checkbox"/>	<input checked="" type="checkbox"/>	Bus communication is OK Module status reports an error
<input type="checkbox"/>	<input checked="" type="checkbox"/>	Bus communication is not possible Module status reports an error
<input type="checkbox"/>	<input type="checkbox"/>	Error at bus power supply
<input type="checkbox"/>	<input checked="" type="checkbox"/>	Error in configuration

LED		Description
PS	<input checked="" type="checkbox"/> green	Protocol status
	<input checked="" type="checkbox"/> green 2Hz	Safety parametrization expected
	<input checked="" type="checkbox"/> green 0.5Hz	Error - acknowledgement expected
	<input type="checkbox"/>	Module initialization is running
ERR	<input checked="" type="checkbox"/> red	Permanent fail-safe condition
	<input checked="" type="checkbox"/> red	Blink code ↪ 'ERR LED' page 32
ER2	<input checked="" type="checkbox"/> yellow	Blink code ↪ 'ER2 LED' page 32
	<input checked="" type="checkbox"/> yellow 0.5Hz	Requesting fail-safe state
DI x	<input checked="" type="checkbox"/> green	Digital input is triggered

RUN and MF LED

Each module has the LEDs RUN and MF on its front side. Errors or incorrect modules may be located by means of these LEDs.

In the following illustrations flashing LEDs are marked by ☼.

RUN and MF LED - Sum current of the electronic power supply exceeded

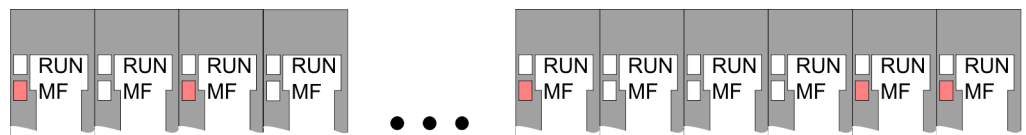

**Behaviour:** After PowerON the RUN LED of each module is off and the MF LED of each module is sporadically on.

**Cause:** The maximum current for the electronic power supply is exceeded.

**Remedy:** As soon as the sum current of the electronic power supply is exceeded, always place the power module 007-1AB10. ↪ Chap. 3.7 'Wiring' page 88

### RUN and MF LED - Error in configuration

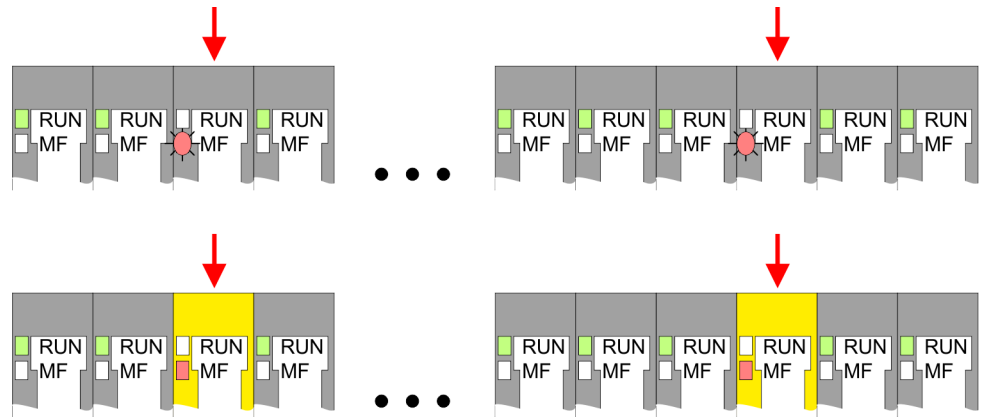

#### Behaviour:

- Standard module: After PowerON the MF LED of one standard module respectively more standard modules blinks. The RUN LED remains off.
- Safety module: After PowerON the MF LED of one safety module respectively more safety modules is on. The RUN LED remains off.

**Cause:** At this position a module is placed, which does not correspond to the configured module.

**Remedy:** Match configuration and hardware structure.

### RUN and MF LED - Module failure

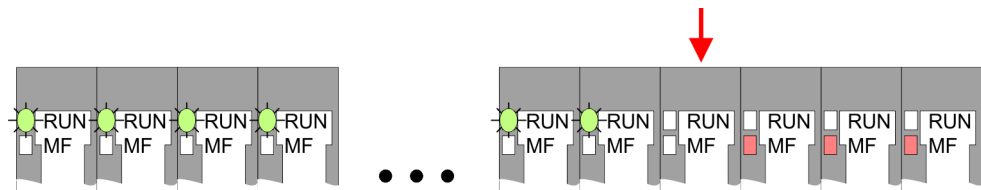

**Behaviour:** After PowerON all of the RUN LEDs up to the defective module are flashing. With all following modules the MF LED is on and the RUN LED is off.

**Cause:** The module on the right of the flashing modules is defective.

**Remedy:** Replace the defective module.

**ERR LED**

The LED is permanently on at a critical error, which led into a permanent fail-safe state, which may not be acknowledged.

On error like short-circuit, cross-circuit and so on, the ERR LED shows an error by the following blink behaviour. The LED gets off for 2s. Then it shows the following code 1 ... 6 by blinking with 1Hz:

**Blink code**

Blinking	Error	External error
1x	Short-circuit within a channel to DC 24V.	yes
2x	Cross-circuit error between 2 channels.	yes
3x	Discrepancy error between 2 channels.	yes
4x	---	---
5x	Other errors.	no
6x	F-address was changed.  The F-address set with the DIP switches does not match the stored F-address, i.e. the safety module has already been parametrized appropriately and then the F-address has been changed. ↪ <i>Chap. 3.4 'Setting the F-address' page 75</i>	no

After the blink code the LED gets off for 2s and then starts again with the code output. Normally an *external error* is caused by wiring respectively by a connected sensor. Please check also your parameters for the sensor.

**ER2 LED**

If an external error was reported by the ERR LED, the LED ER2 indicates the faulty channel by the following blink code:

- The ER2 LED gets off for 2s.
- Then it indicates the number of the faulty channel by blinking with 1Hz. Here it is valid blinking 1x...4x means channel DI 0 ... 3.
- After the blink code the LED gets off for 2s and then starts again with the code output.
- If there are more errors pending, only the 1. recognized error is indicated.
- If the LED blinks with 0.5Hz the safety PLC requests a fail-safe state of the System SLIO safety module. But there is no error on the System SLIO safety module. This request may occur, for example after a brief interrupt of the communication and may be acknowledged. ↪ *Chap. 3.18 'Sample application' page 122*



## Terminal

For wires with a core cross-section of 0.08mm<sup>2</sup> up to 1.5mm<sup>2</sup>.

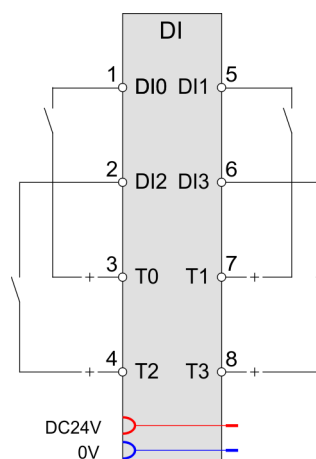
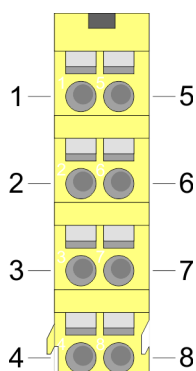

Pos.	Function	Type	Description
1	DI 0	I	Digital input DI 0
2	DI 2	I	Digital input DI 2
3	T0	O	Clock output T0
4	T2	O	Clock output T2
5	DI 1	I	Digital input DI 1
6	DI 3	I	Digital input DI 3
7	T1	O	Clock output T1
8	T3	O	Clock output T3

I: Input, O: Output

**Address switch for F-address**

The F-address is to be configured by the F-address switch at the safety module and additionally in the master system e.g. hardware configurator. The F-address is to be set by the F-address switch besides on the safety module. Only if the F-address set in the hardware configurator accords to the setting of the F-address switch, it is possible to operate!

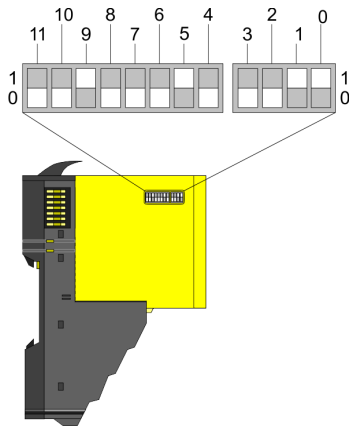

Pos.	Value	Example	
		State	Address
0	1	1	1+2+32+512=547 Address: 547
1	2	1	
2	4	0	
3	8	0	
4	16	0	
5	32	1	
6	64	0	
7	128	0	
8	256	0	
9	512	1	
10	1024	0	
11	2048	0	



**When the module is installed, the F-address switch may not be accessed!**

To set the F-address on the safety module the (electronic) module is to be demounted before as described at "Demounting and module exchange". ↪ Chap. 3.6 'Demounting and module exchange' page 84

## 2.4 SDI 4xDC 24V - IO structure

### IO structure for the input module

Index	Subindex	Type	Bit	Name
<b>Rx direction</b>				
0x7000	1	USINT	8	FSoE Master Command
0x7001	1	USINT	8	Data
0x7000	2	UINT	16	FSoE Master CRC 0
0x7000	3	UINT	16	FSoE Master Connection ID
<b>Tx direction</b>				
0x6000	1	USINT	8	FSoE Slave Command
0x6001	1	BOOL	1	DI0
0x6001	2	BOOL	1	DI1
0x6001	3	BOOL	1	DI2
0x6001	4	BOOL	1	DI3
0x0			4	
0x6000	2	UINT	16	FSoE Slave CRC 0
0x6000	3	UINT	16	FSoE Slave Connection ID

## 2.5 SDI 4xDC 24V - FSoE Parameter record set

### 2.5.1 FSoE application parameters

#### Record set 0x8000

This data record set is transmitted once via the FSoE mechanism when the FSoE master system is started.

#### Parameter

Sub-index	Name	Description / Range of values	Type	Bit	Offset	Access	Default
0	Subindex 000		USINT	8	0	ro	22
1	Version identifier of the parametrization data structure	0x0001: first version	UINT16	16	16	rw	1
2	Module type identifier	Unique module identifier	UDINT	32	32	rw	0x0C429E00
3	Channel 0, 1: Discrepancy error (reintegration after discrepancy error)	Condition channel 0, 1 activation on "activated" Condition channel 0, 1 evaluation of the inputs to "2-channel" 0: Test 0 signal required 1: Test 0 signal not required	BOOL	1	64	rw	0
4	Channel 0, 1: Signal polarity	Condition channel 0, 1 activation on "activated" Condition channel 0, 1 evaluation of the inputs to "2-channel" 0: equivalent 1: antivalent	BOOL	1	65	rw	0
5	Channel 0, 1: Evaluation of the inputs	Condition channel 0, 1 activation on "activated" 0: 1-channel 1: 2-channel	BOOL	1	66	rw	1
6	Channel 0, 1: Test pulse activation	Condition: Channel 0, 1 activation on "activated" 0: activated 1: deactivated Test pulse activation activates both short-circuit and cross-circuit detection.	BOOL	1	67	rw	0
7	Channel 0, 1: Activation	0: deactivated 1: activated	BOOL	1	68	rw	1
11	Channel 2, 3: Discrepancy error (reintegration after discrepancy error)	Condition channel 2, 3 activation on "activated" Condition channel 2, 3 evaluation of the inputs to "2-channel" 0: Test 0 signal required 1: Test 0 signal not required	BOOL	1	72	rw	0

Sub-index	Name	Description / Range of values	Type	Bit	Offset	Access	Default
12	Channel 2, 3: Signal polarity	Condition channel 2, 3 activation on "activated" Condition channel 2, 3 evaluation of the inputs to "2-channel" 0: equivalent 1: antivalent	BOOL	1	73	rw	0
13	Channel 2, 3: Evaluation of the inputs	Condition channel 2, 3 activation on "activated" 0: 1-channel 1: 2-channel	BOOL	1	74	rw	1
14	Channel 2, 3: Test pulse activation	Condition: Channel 2, 3 activation on "activated" 0: activated 1: deactivated Test pulse activation activates both short-circuit and cross-circuit detection.	BOOL	1	75	rw	0
15	Channel 2, 3: Activation	0: deactivated 1: activated	BOOL	1	76	rw	1
16	Parameter change mode	0: Normal parameter record set 1: Parameter change F-address	BOOL	1	77	rw	0
17	Activation diagnostic interrupt	0: deactivated 1: activated Bit is not security relevant.	BOOL	1	78	rw	1
18	Behavior after channel errors	0: Passivate the entire module 1: Passivate the affected channel	BOOL	1	79	rw	0
19	Channel 0, 1: Input smoothing time in ms	Condition: Channel 0, 1 activation on "activated" 1-1000	UINT	16	80	rw	1
20	Channel 0, 1: Discrepancy time in ms	Condition channel 0, 1 activation on "activated" Condition channel 0, 1 evaluation of the inputs to "2-channel" 1-30000	UINT	16	96	rw	20

Sub-index	Name	Description / Range of values	Type	Bit	Offset	Access	Default
21	Channel 2, 3: Input smoothing time in ms	Condition: Channel 2, 3 activation on "activated" 1-1000	UINT	16	112	rw	1
22	Channel 2, 3: Discrepancy time in ms	Condition channel 2, 3 activation on "activated" Condition channel 2, 3 evaluation of the inputs to "2-channel" 1-30000	UINT	16	128	rw	20

**Version identifier of the parametrization data structure**

The version identifier is specific to a module type, i.e. for the input module and the output module, which have different parameter data, each version is started with 0x0001.



*In the MX file, the identifier 0x0000 is entered so that the firmware can recognize that this is an invalid parametrization. The safety IO module must not start up with the default values stored in the MX file.*

**Module type identifier**

Unique module identifier, which is also used e.g. in the ESI file.

**Parameter change mode**

For a valid parametrization this parameter must be set to 0 (default value). If the F-address is to be changed for a System SLIO safety module, you can delete the F-address in the memory of the System SLIO safety module by setting this parameter. ↪ *Chap. 3.4 'Setting the F-address' page 75*

**Behavior after channel errors**

If the SDI module detects an error on one of the input channels (e.g. short-circuit), the entire System SLIO safety module is passivated. Here, the module provides the safety PLC as long with the fail-safe value 0 for the inputs until the error is fixed and acknowledged. ↪ *Chap. 3.18 'Sample application' page 122*

**Activation diagnostic interrupt**

Here you activate respectively deactivate the diagnostic interrupt function. With a set diagnostic interrupt bit in case of an error a diagnostic interrupt message is sent to the upper master system. There the diagnostics message can further be processed. More may be found in the manual of the master system.

**Channel activation**

- With the *channel activation* channel groups may be activated or deactivated. With *channel activation* = 1 the corresponding channel group is in "standard operation".
- Deactivated channel groups (*channel activation* = 0) permanently supply a logical 1 as input information to the safety PLC in the cyclic data exchange as long as the module is not passivated. This serves to bridge non-existent sensors, e.g. during commissioning or with machine variants, without adapting the safety program in the safety PLC.

**CAUTION!**

Deactivation of channel groups represents a potentially dangerous condition!

The usage of *channel activation* must already be taken into account when planning and creating the safety program!

**Input smoothing time**

Errors on the input signals can be suppressed by specifying an *input smoothing time*. This is used for debouncing sensors. If there is an active safety sensor connected to an input, which tests the wired lines by test pulses, then the *input smoothing time* must always be greater than the max. test pulse length of the sensor. Please also refer to the "Connection examples". ↪ [Chap. 3.8 'Connection examples' page 96](#)



The *input smoothing time* is included in the calculation of the max. system response time! ↪ [Chap. 2.11 'Response time' page 60](#)

**Test pulse activation**

- When using sensors with mechanical or electromechanical contacts, to detect a short circuit to DC 24V, for each channel group a test pulse can be activated. For test pulse output the System SLIO safety module has a DC 24V power supply output for each channel group.
- When activated (*test pulse activation* = 0) the DC 24V power supply output is shortly set to 0V at defined intervals. Here the return of the test pulse is observed by each input channel, provided the sensor is currently closed. Here wiring errors or short and cross circuits can be detected.
- This function is to be deactivated (*test pulse activation* = 1) if there is an active sensor (e.g. light array) connected to the input with integrated electronic and semiconductor output. Here the active sensor serves for the observation of the connected lines by generating the test pulse to check the switch-off ability. Here the input smoothing time of the corresponding safety input must be greater than the test pulse length of the output of the safety sensor (vendor information). Please also refer to the "Connection examples". ↪ [Chap. 3.8 'Connection examples' page 96](#)

**Evaluation of the inputs**

Here for each channel group you can set the evaluation of the inputs as 1-channel or 2-channel evaluation:

- With "1-channel" evaluation connect a sensor with 1 output one sensor with one output to one channel.
- For "2-channel" evaluation, connect a sensor with 2 outputs to a channel group. Here the sensor supplies by both connectors the same signal state. With "2-channel" evaluation more short and cross circuits may be detected as with "1-channel" evaluation. This kind of 2-channel connection allows to achieve higher safety levels like SIL 3 and PL e. Please also refer to the "Connection examples". ↪ [Chap. 3.8 'Connection examples' page 96](#)

### Signal polarity

With the signal polarity parameter you can physically adapt the inputs of your System SLIO safety module to the signal polarity of your sensor for 2-channel evaluation. The 1. channel always supplies the current input signal of the sensor. Independent of the signal polarity, in the safety control system the resulted input value (corresponds to the polarity of the 1. channel) is passed to both input bits of a channel group.

- With *equivalent* signal polarity the 2. channel supplies the same value as the 1. channel.
- With an *antivalent* signal polarity the signal is inverted by the 2. channel of the sensor. Antivalent signals are used, e.g. in the wiring of security doors. By this way simple manipulations can be prevented.

### Discrepancy time

- During the switching operation of 2-channel sensors, temporarily both channels do not supply the same signal state. With the *discrepancy time* you can set the time until both channels have valid values after switching.
- If the discrepancy time is exceeded, the System SLIO safety module switches to the fail-safe state.
- It is valid for electrical and electromechanical sensors:  
*Discrepancy to be set* = real signal discrepancy (switch and bounce time of the sensor) + set *Input smoothing time* + 7 ms
- It is valid for active sensors with semiconductor output (and own test pulse generation):  
*Discrepancy to be set* = real signal discrepancy + set *Input smoothing time* \* 3 + 4 ms



*Please consider with mechanical sensors and increasing abrasion by e.g. contact bounce, the discrepancy time increases and this is reported as error by the System SLIO safety module.*

*In this case, in order to avoid failure of a sensor, during operation a defective sensor must immediately be changed!*

### Reintegration after discrepancy error

This parameter allows you to define how you can acknowledge a discrepancy error.

- With 0 of this parameter, a discrepancy error can only be acknowledged when the sensor supplies 0 signal. For example, an emergency stop switch must be pressed.
- With 1 of this parameter, a discrepancy error can only be acknowledged when both sensors supply a valid signal state (depending on the parametrization equivalent or antivalent).

🔗 *Chap. 3.18 'Sample application' page 122*



## 2.5.2 FSoE communication parameters

### Record set 0x9001

Sub-index	Name	Description / range of values	Type	Bit	Offset	Access	Default	Transfer <sup>1</sup>
0	SubIndex 000		USINT	8	0	ro	9	
1	Version	Supported FSoE version	STRING (2)	16	16	ro	-	No
2	Safety Address	Safety address	UINT	16	32	ro	0	No
3	FSoE connection ID	Safety connection ID	UINT	16	48	ro	-	No
4	Watchdog Time	Safety watchdog time in ms 20 - 65534	UINT	16	64	ro	150	Yes
5	Unique Device ID	Unique device ID	ARRAY [0..5] OF BYTE	48	80	ro	-	No
6	Connection Type	0: Master connection 1: Slave connection	UINT	16	128	ro	1	No
7	ComParameterLength	Length of communication parameters in the parameter set	UINT	16	144	ro	2	Yes
8	ApplParameterLength	Length of application parameters in the parameter set	UINT	16	160	ro	16	Yes
9	SRA CRC	CRC checksum of the corresponding application parameter set	UDINT	32	176	ro	-	No

1) Parameters that are marked with 'Yes' are transferred via the FSoE mechanism once when the FSoE master system is started.

### Watchdog time (FSoE\_WD\_Time)

- The *watchdog time* parameter determines the monitoring time for the communication between the safety PLC and the System SLIO safety module.
- Within the monitoring time, at least one valid telegram must be exchanged between the safety PLC and the System SLIO safety module. In this case, the I/O data of the EtherCAT telegrams are correspondingly copied into the I/O areas of the safety PLC.
- In the safety PLC, the I/O data of the EtherCAT telegrams are correspondingly copied into the I/O areas of the safety PLC.
- If this condition is not fulfilled, a safe state is initiated by the safety PLC or by the System SLIO safety module.
- The monitoring time must be selected so that telegram runtimes are tolerated, but a break in the connection is detected quickly enough.
- The monitoring time can be specified in steps of 1ms. The possible range of values (20 - 65534 ms) is specified by the device description file.
- Information on the calculation can be found below.

**Calculating the watchdog time**

So that the watchdog running in the System SLIO safety modules is regularly reset, that it does not trigger, the following cyclical data flow should be considered:

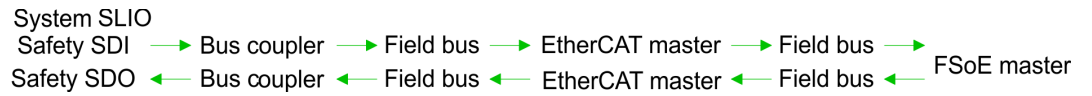

$$T_{PSTO} = T_{DAT} + T_{ECS} + T_{BUS} + T_{CI} + T_{BUS} + T_{ECM} + T_{BUS} + T_{CI} + T_{BUS} + T_{ECS} + T_{DAT}$$

$$T_{PSTO} = 2 \cdot T_{DAT} + 2 \cdot T_{ECS} + 4 \cdot T_{BUS} + 2 \cdot T_{CI} + T_{ECM}$$

$T_{PSTO}$  - Configured safety monitoring time (*FSoE\_WD\_Time*)

$T_{DAT}$  - Max. Acknowledgement time of the System SLIO safety modules (Device acknowledgement time)

$T_{ECS}$  - Max. Response time of the EtherCAT slave, i.e. max. delay due to the EtherCAT coupler and the backplane bus.

$T_{BUS}$  - Time for EtherCAT bus transfer

$T_{CI}$  - Configured cycle time of the safety PLC

$T_{ECM}$  - Max. Response time of the EtherCAT slave.

**2.6 SDI 4xDC 24V - Technical data**

<b>Order no.</b>	<b>021-1SD10</b>
Type	SM 021
Module ID	0C42 9E00
<b>Current consumption/power loss</b>	
Current consumption from backplane bus	95 mA
Power loss	0.8 W
<b>Technical data digital inputs</b>	
Number of inputs	4
Cable length, shielded	330 m
Cable length, unshielded	330 m
Rated load voltage	-
Current consumption from load voltage L+ (without load)	2 mA
Rated value	DC 20.4...28.8 V
Input voltage for signal "0"	DC 0...5 V
Input voltage for signal "1"	DC 11...28.8 V
Input voltage hysteresis	-
Signal logic input	Sinking input
Frequency range	-
Input resistance	-
Input capacitance	100 nF

<b>Order no.</b>	<b>021-1SD10</b>
Input current for signal "1"	3 mA
Connection of Two-Wire-BEROs possible	✓
Max. permissible BERO quiescent current	1.5 mA
Input delay of "0" to "1"	parameterizable 1ms - 1s
Input delay of "1" to "0"	parameterizable 1ms - 1s
Number of simultaneously utilizable inputs horizontal configuration	4
Number of simultaneously utilizable inputs vertical configuration	4
Input characteristic curve	IEC 61131-2, type 3
Initial data size	4 Bit
<b>Status information, alarms, diagnostics</b>	
Status display	green LED per channel
Interrupts	yes, parameterizable
Process alarm	no
Diagnostic interrupt	yes, parameterizable
Diagnostic functions	yes, parameterizable
Diagnostics information read-out	possible
Module state	green LED
Module error display	red LED
Channel error display	red ERR-LED and yellow ER2-LED
<b>Isolation</b>	
Between channels	-
Between channels of groups to	-
Between channels and backplane bus	✓
Insulation tested with	DC 500 V
<b>Safety</b>	
Safety protocol	-
Safety requirements	SIL CL 3, PL e, Kat 4
Secure user address	1 - 4095
Watchdog	parameterizable 20ms - 65s
Two channels	Each 2 of 4 inputs switchable
Test pulse outputs	4
<b>Datasizes</b>	
Input bytes	6
Output bytes	6
Parameter bytes	16

## SDI 4xDC 24V - Technical data

<b>Order no.</b>	<b>021-1SD10</b>
Diagnostic bytes	20
<b>Housing</b>	
Material	PC / PPE GF10
Mounting	Profile rail 35 mm
<b>Mechanical data</b>	
Dimensions (WxHxD)	12.9 mm x 109 mm x 76.5 mm
Net weight	63 g
Weight including accessories	68 g
Gross weight	84 g
<b>Environmental conditions</b>	
Operating temperature	0 °C to 60 °C
Storage temperature	-25 °C to 70 °C
<b>Certifications</b>	
UL certification	in preparation
KC certification	in preparation



*Please consider that the signal increase of the sensor signals for signal on and signal off must have a slope of at least 13V/s, otherwise an error could be detected by the mutual monitoring of the microcontrollers!*



*Please note that the electrical input stage of safe digital inputs of a System SLIO safety module may affect the test pulses of connected devices (sensors) with OSSD outputs. If the OSSD outputs are of the type "open collector", the input capacitance, which is specified in the technical data here, must be considered as a load capacitance in addition to the cable capacitance. You can find the maximum permissible load capacitance of the sensor in its technical data. If the actual load capacitance is higher than the permitted, then the sensor will falsely detect a short circuit to 24V and switch to a safe state, i.e. these sensors can not be operated on the System SLIO safety module. At OSSD outputs of the type "push-pull" the specified input capacitance of the test pulses of the sensor are not relevant.*

## 2.7 SDO 4xDC 24V 0.5A - Operating and display elements

### Description

The electronic module accepts binary control signals from the central bus system and transfers them to the process level via outputs. It has 4 channels and their status is monitored via LEDs.

### Properties

- 4 digital outputs isolated to the backplane bus
- Status indication of the channels via LEDs
- Safety module with automatic disconnection in case of error according to IEC 61508 SIL3 and EN ISO 13849-1, Cat.4 / PL e

### Structure

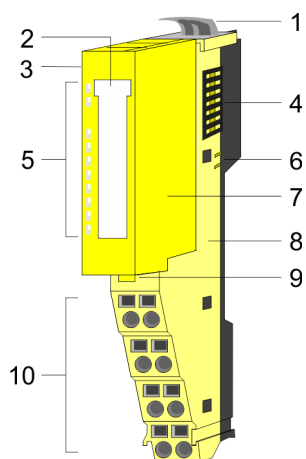

- 1 Locking lever terminal module
- 2 Labeling strip
- 3 Address switch for F-address
- 4 Backplane bus
- 5 LED status indication
- 6 DC 24V power section supply
- 7 Electronic module
- 8 Terminal module
- 9 Locking lever electronic module
- 10 Terminal

Status indication

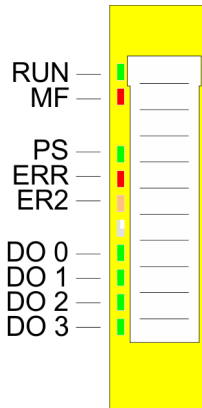

RUN ■ green	MF ■ red	Description
■	□	Bus communication is OK Module status is OK
■	■	Bus communication is OK Module status reports an error
□	■	Bus communication is not possible Module status reports an error
□	□	Error at bus power supply
□	■	Error in configuration

LED		Description
PS	■ green	Protocol status
	▣ green 2Hz	Safety parametrization expected
	▣ green 0.5Hz	Error - acknowledgement expected
	□	Module initialization is running
ERR	■ red	Permanent fail-safe condition
	▣ red	Blink code ↪ 'ERR LED' page 48
ER2	▣ yellow	Blink code ↪ 'ER2 LED' page 48
	▣ yellow 0.5Hz	Requesting fail-safe state
DO x	■ green	Digital output is triggered

RUN and MF LED

Each module has the LEDs RUN and MF on its front side. Errors or incorrect modules may be located by means of these LEDs.

In the following illustrations flashing LEDs are marked by ☼.

RUN and MF LED - Sum current of the electronic power supply exceeded

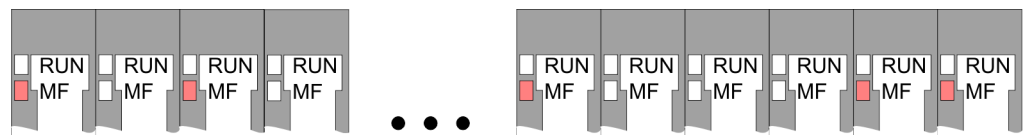

**Behaviour:** After PowerON the RUN LED of each module is off and the MF LED of each module is sporadically on.

**Cause:** The maximum current for the electronic power supply is exceeded.

**Remedy:** As soon as the sum current of the electronic power supply is exceeded, always place the power module 007-1AB10. ↪ Chap. 3.7 'Wiring' page 88

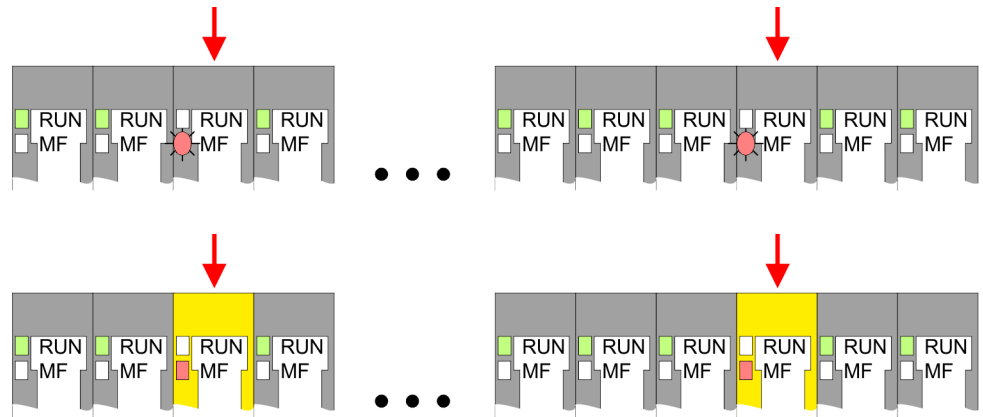
**RUN and MF LED - Error in configuration****Behaviour:**

- Standard module: After PowerON the MF LED of one standard module respectively more standard modules blinks. The RUN LED remains off.
- Safety module: After PowerON the MF LED of one safety module respectively more safety modules is on. The RUN LED remains off.

**Cause:** At this position a module is placed, which does not correspond to the configured module.

**Remedy:** Match configuration and hardware structure.

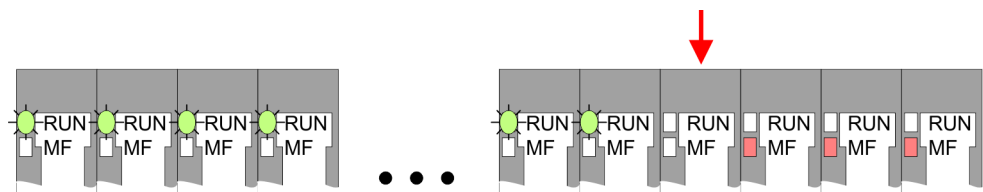
**RUN and MF LED - Module failure**

**Behaviour:** After PowerON all of the RUN LEDs up to the defective module are flashing. With all following modules the MF LED is on and the RUN LED is off.

**Cause:** The module on the right of the flashing modules is defective.

**Remedy:** Replace the defective module.

**ERR LED**

The LED is permanently on at a critical error, which led into a permanent fail-safe state, which may not be acknowledged.

On error like short-circuit, cross-circuit and so on, the ERR LED shows an error by the following blink behaviour. The LED gets off for 2s. Then it shows the following code 1 ... 6 by blinking with 1Hz:

**Blink code**

Blinking	Error	External error
1x	Short-circuit within a channel to DC 24V.	yes
2x	Cross-circuit error between 2 channels.	yes
3x	Wire break error at a channel (current < 30mA). ↳ <i>Chap. 2.9 'SDO 4xDC 24V 0.5A - FSoE Parameter record set' page 52</i>	yes
4x	Read back error i.e. at a channel the setpoint state and the actual state do not match e.g. short circuit to earth.	yes
5x	Other errors	no
6x	F-address was changed.  The F-address set with the DIP switches does not match the stored F-address, i.e. the safety module has already been parametrized appropriately and then the F-address has been changed. ↳ <i>Chap. 3.4 'Setting the F-address' page 75</i>	no

- After the blink code the LED gets off for 2s and then starts again with the code output. Normally an *external error* is caused by wiring respectively by a connected sensor. Please check also your parameters for the actuator.
- The System SLIO safety output module monitors the actual state of the output voltage level monitoring with the setpoint state (control).
- If there is a difference between the setpoint state and the actual state detected, a read back error is reported.  
This can either mean that the output is "1" state, although it should have "0" state (points to a separate power supply) or the output has "0" state, although it should have "1" state (points to an external short circuit or an internal hardware malfunction).  
In this case of error please check the external wiring and the configured test pulse length. If they are OK and the error occurs several times in succession, then the module is defective and you have to proceed as described at "Repair". ↳ *Chap. 3.14 'Repair' page 113*

**ER2 LED**

If an external error was reported by the ERR LED, the LED ER2 indicates the faulty channel by the following blink code:

- The ER2 LED gets off for 2s.
- Then it indicates the number of the faulty channel by blinking with 1Hz. Here it is valid blinking 1x...4x means channel DO 0 ... 3.
- After the blink code the LED gets off for 2s and then starts again with the code output.
- If there are more errors pending, only the 1. recognized error is indicated.
- If the LED blinks with 0.5Hz the safety PLC requests a fail-safe state of the System SLIO safety module. But there is no error on the System SLIO safety module. This request may occur, for example after a brief interrupt of the communication and may be acknowledged.



## Terminal

For wires with a core cross-section of 0.08mm<sup>2</sup> up to 1.5mm<sup>2</sup>.

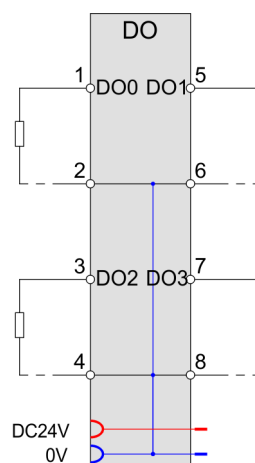
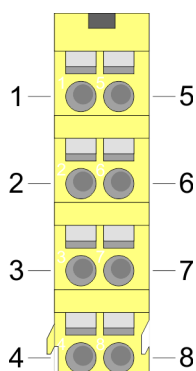

Pos.	Function	Type	Description
1	DO 0	O	Digital output DO 0
2	0V	O	GND for actuator
3	DO 2	O	Digital output DO 2
4	0V	O	GND for actuator
5	DO 1	O	Digital output DO 1
6	0V	O	GND for actuator
7	DO 3	O	Digital output DO 3
8	0V	O	GND for actuator

I: Input, O: Output

**Address switch for F-address**

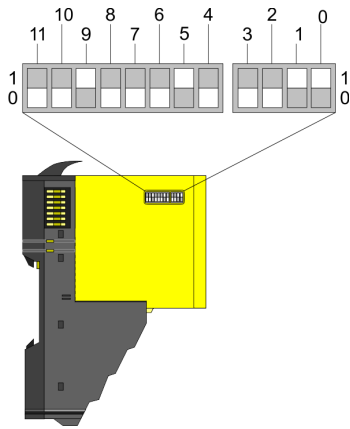

The F-address is to be configured by the F-address switch at the safety module and additionally in the master system e.g. hardware configurator. The F-address is to be set by the F-address switch besides on the safety module. Only if the F-address set in the hardware configurator accords to the setting of the F-address switch, it is possible to operate!

Pos.	Value	Example	
		State	Address
0	1	1	1+2+32+512=547 Address: 547
1	2	1	
2	4	0	
3	8	0	
4	16	0	
5	32	1	
6	64	0	
7	128	0	
8	256	0	
9	512	1	
10	1024	0	
11	2048	0	



**When the module is installed, the F-address switch may not be accessed!**

To set the F-address on the safety module the (electronic) module is to be demounted before as described at "Demounting and module exchange". ↪ Chap. 3.6 'Demounting and module exchange' page 84

## 2.8 SDO 4xDC 24V 0.5A - IO structure

### IO structure for the output module

Index	Subindex	Type	Bit	Name
<b>Rx direction</b>				
0x7000	1	USINT	8	FSoE Master Command
0x7001	1	BOOL	1	DO0
0x7001	2	BOOL	1	DO1
0x7001	3	BOOL	1	DO2
0x7001	4	BOOL	1	DO3
0x0			4	
0x7000	2	UINT	16	FSoE Master CRC 0
0x7000	3	UINT	16	FSoE Master Connection ID
<b>Tx direction</b>				
0x6000	1	USINT	8	FSoE Slave Command
0x6001	1	USINT	8	Data
0x6000	2	UINT	16	FSoE Slave CRC 0
0x6000	3	UINT	16	FSoE Slave Connection ID

## 2.9 SDO 4xDC 24V 0.5A - FSoE Parameter record set

### 2.9.1 FSoE application parameters

#### Record set 0x8000

This data record set is transmitted once via the FSoE mechanism when the FSoE master system is started.

#### Parameter

Sub-index	Name	Description / Range of values	Type	Bit	Offset	Access	Default
0	Subindex 000		USINT	8	0	ro	22
1	Version identifier of the parametrization data structure	0x0001: first version	UINT16	16	16	rw	1
2	Module type identifier	Unique module identifier	UDINT	32	32	rw	0x0C82AE00
3	Channel 0: Wire break detection	Condition: Channel 0, 1 activation on "activated" 0: deactivated 1: activated Bit is not security relevant.	BOOL	1	64	rw	0
4	Channel 1: Wire break detection	Condition: Channel 0, 1 activation on "activated" 0: deactivated 1: activated Bit is not security relevant.	BOOL	1	65	rw	0
5	Channel 0, 1: Activation mode	Condition: Channel 0, 1 activation on "activated" 0: 1-channel 1: 2-channel	BOOL	1	66	rw	1
6	Channel 0, 1: Activation <sup>1</sup>	0: deactivated 1: activated	BOOL	1	67	rw	1
7	Channel 2: Wire break detection	Condition: Channel 2, 3 activation on "activated" 0: deactivated 1: activated Bit is not security relevant.	BOOL	1	68	rw	0
8	Channel 3: Wire break detection	Condition: Channel 2, 3 activation on "activated" 0: deactivated 1: activated Bit is not security relevant.	BOOL	1	69	rw	0
9	Channel 2, 3: Activation mode	Condition: Channel 2, 3 activation on "activated" 0: 1-channel 1: 2-channel	BOOL	1	70	rw	1
10	Channel 2, 3: Activation <sup>1</sup>	0: deactivated 1: activated	BOOL	1	71	rw	1

Sub-index	Name	Description / Range of values	Type	Bit	Offset	Access	Default
16	Parameter change mode	0: Normal parameter record set 1: Parameter change F-address	BOOL	1	77	rw	0
17	Activation Diagnostic interrupt	0: deactivated 1: activated Bit is not security relevant.	BOOL	1	78	rw	1
19	Channel 0: Test pulse length in $\mu$ s	Condition: Channel 0, 1 activation on "activated" Different values selectable (1ms, 1.5ms, 2ms, 2.5ms, ... ,10ms)	BOOL	16	80	rw	1000
20	Channel 1: Test pulse length in $\mu$ s	Condition: Channel 0, 1 activation on "activated" Different values selectable (1ms, 1.5ms, 2ms, 2.5ms, ... ,10ms)	BOOL	16	96	rw	1000
21	Channel 2: Test pulse length in $\mu$ s	Condition: Channel 2, 3 activation on "activated" Different values selectable (1ms, 1.5ms, 2ms, 2.5ms, ... ,10ms)	UINT	16	112	rw	1000
22	Channel 3: Test pulse length in $\mu$ s	Condition: Channel 2, 3 activation on "activated" Different values selectable (1ms, 1.5ms, 2ms, 2.5ms, ... ,10ms)	UINT	16	128	rw	1000

1) Deactivation of channel groups deviates from "normal operation" and represents a potentially dangerous condition.

### Version identifier of the parametrization data structure

The version identifier is specific to a module type, i.e. for the input module and the output module. Since these have different parameter data, in each case with version 0x0001 is started.



*In the MX file, the identifier 0x0000 is entered so that the firmware can recognize that this is an invalid parametrization. The safety IO module must not start up with the default values stored in the MX file.*

### Module type identifier

Unique module identifier, which is also used e.g. in the ESI file.

### Parameter change mode

For a valid parametrization this parameter must be set to 0 (default value). If the F-address is to be changed for a System SLIO safety module, you can delete the F-address in the memory of the System SLIO safety module by setting this parameter. ↪ *Chap. 3.4 'Setting the F-address' page 75*

**Activation diagnostic interrupt**

Here you activate respectively deactivate the diagnostic interrupt function. With a set diagnostic interrupt bit in case of an error a diagnostic interrupt message is sent to the upper master system. There the diagnostics message can further be processed. More may be found in the manual of the master system.

**Channel activation**

- With the *channel activation* channel groups may be activated or deactivated. With *channel activation* = 1 the corresponding channel group is in "standard operation".
- Deactivated channel groups (*channel activation* = 0) permanently provide a logical 0 as output signal, independent from the defined signal of the safety PLC. This can be useful during the first start-up.

**NOTICE!**

Deactivation of channel groups represents a potentially dangerous condition!

**Activation mode**

Here you can specify for each channel group, if the outputs of the safety output module are controlled by the safety PLC individually (*1-channel*) or in pairs (*2-channel*). The paired control option simplifies the creation of the safety logic in the safety PLC. Please consider that regardless of the type of the activation mode, in the System SLIO safety module, each output is always 2-channel driven and switched off (double PP switching).

- With *1-channel* 1 or 2 actuators with one input are connected to one channel. Here respectively one bit is used to control an output. By means of 2-channel actuators, a higher safety level like SIL3 or PLe can be achieved, if you can exclude the errors cross-circuit or external power supply or there is a superior shut-down on error.
- With *2-channel* a 2-channel actuator with 2 inputs or 2 actuators with respectively 1 input are connected to a channel group. Here bit 0 switches the outputs DO 0 and DO 1 respectively bit 2 switches the outputs DO 2 and DO 3. Here the actuator / actuators get the output signal via both channels. Errors in cross circuits and external power supply at the channel group can be identified and controlled, if this relates to only one of the two lines. This enables to achieve higher safety levels like SIL 3 and PLe. ↪ *Chap. 3.8.2 'Connection examples for digital safety outputs' page 101*

**NOTICE!**

In case of error with a switched-off output, a short-time turn-on pulse with a max. length of the error detection time can occur.

The error detection time is  $6\text{ms} + 2 \times \text{test pulse length}$ .

**Wire break detection**

If this parameter is set, the System SLIO safety module observes the outputs with output state "1", whether there is a min. current of 10mA...30mA. By this way a line break can be detected. Here the System SLIO safety module gets to fail-safe state and the outputs are switched off.

**CAUTION!**

This function must not be used as safety function. This means a safety function must not depend on this function.

**Test pulse length**

Each output with "1" state is continuously observed whether this can still be switched off. Here wiring errors e.g. short circuit to DC 24V and errors within the System SLIO safety module can be detected. The *test pulse length* must be set depending on cable capacitance and the load current.



*If the test pulse length is too long, a connected actuator may briefly switch off during the test pulse, or if there is another security device connected, this can recognize a 0-signal and turn off incorrectly!*

*If the test pulse length is too short, the System SLIO safety module reports an error, because here it is not possible for the module to test the switch-off ability of an output. Then the module reports "short circuit".*

**Orientation values for the *test pulse length***

Load current	Cable length (capacity, resistor)	Test pulse length to be configured
2 mA	100 m (30 nF, up to 6.7 Ohm)	3000 µs
2 mA	333 m (100 nF, up to 22.4 Ohm)	4500 µs
2 mA	1000 m (300 nF, up to 67 Ohm)	8000 µs
5 mA	100 m (30 nF, up to 6.7 Ohm)	2000 µs
5 mA	333 m (100 nF, up to 22.4 Ohm)	2500 µs
5 mA	1000 m (300 nF, up to 67 Ohm)	4500 µs
> 25 mA	100 m (30 nF, up to 6.7 Ohm)	1000 µs
> 25 mA	333 m (100 nF, up to 22.4 Ohm)	1500 µs
> 25 mA	1000 m (300 nF, up to 67 Ohm)	1500 µs

## 2.9.2 FSoE communication parameters

### Record set 0x9001

Sub-index	Name	Description / range of values	Type	Bit	Offset	Access	Default	Transfer <sup>1</sup>
0	SubIndex 000		USINT	8	0	ro	9	
1	Version	Supported FSoE version	STRING (2)	16	16	ro	-	No
2	Safety Address	Safety address	UINT	16	32	ro	0	No
3	FSoE connection ID	Safety connection ID	UINT	16	48	ro	-	No
4	Watchdog Time	Safety watchdog time in ms 20 - 65534	UINT	16	64	ro	150	Yes
5	Unique Device ID	Unique device ID	ARRAY [0..5] OF BYTE	48	80	ro	-	No
6	Connection Type	0: Master connection 1: Slave connection	UINT	16	128	ro	1	No
7	ComParameterLength	Length of communication parameters in the parameter set	UINT	16	144	ro	2	Yes
8	ApplParameterLength	Length of application parameters in the parameter set	UINT	16	160	ro	16	Yes
9	SRA CRC	CRC checksum of the corresponding application parameter set	UDINT	32	176	ro	-	No

1) Parameters that are marked with 'Yes' are transferred via the FSoE mechanism once when the FSoE master system is started.

### Watchdog time (FSoE\_WD\_Time)

- The *watchdog time* parameter determines the monitoring time for the communication between the safety PLC and the System SLIO safety module.
- Within the monitoring time, at least one valid telegram must be exchanged between the safety PLC and the System SLIO safety module. In this case, the I/O data of the EtherCAT telegrams are correspondingly copied into the I/O areas of the safety PLC.
- In the safety PLC, the I/O data of the EtherCAT telegrams are correspondingly copied into the I/O areas of the safety PLC.
- If this condition is not fulfilled, a safe state is initiated by the safety PLC or by the System SLIO safety module.
- The monitoring time must be selected so that telegram runtimes are tolerated, but a break in the connection is detected quickly enough.
- The monitoring time can be specified in steps of 1ms. The possible range of values (20 - 65534 ms) is specified by the device description file.
- Information on the calculation can be found below.



**Calculating the watchdog time**

So that the watchdog running in the System SLIO safety modules is regularly reset, that it does not trigger, the following cyclical data flow should be considered:

System SLIO

Safety SDI → Bus coupler → Field bus → EtherCAT master → Field bus → FSoE master  
 Safety SDO ← Bus coupler ← Field bus ← EtherCAT master ← Field bus ← FSoE master

$$T_{PSTO} = T_{DAT} + T_{ECS} + T_{BUS} + T_{CI} + T_{BUS} + T_{ECM} + T_{BUS} + T_{CI} + T_{BUS} + T_{ECS} + T_{DAT}$$

$$T_{PSTO} = 2 \cdot T_{DAT} + 2 \cdot T_{ECS} + 4 \cdot T_{BUS} + 2 \cdot T_{CI} + T_{ECM}$$

$T_{PSTO}$  - Configured safety monitoring time (*FSoE\_WD\_Time*)

$T_{DAT}$  - Max. Acknowledgement time of the System SLIO safety modules (Device acknowledgement time)

$T_{ECS}$  - Max. Response time of the EtherCAT slave, i.e. max. delay due to the EtherCAT coupler and the backplane bus.

$T_{BUS}$  - Time for EtherCAT bus transfer

$T_{CI}$  - Configured cycle time of the safety PLC

$T_{ECM}$  - Max. Response time of the EtherCAT slave.

**2.10 SDO 4xDC 24V 0.5A - Technical data**

Order no.	022-1SD10
Type	SM 022
Module ID	0C82 AE00
<b>Current consumption/power loss</b>	
Current consumption from backplane bus	75 mA
Power loss	1 W
<b>Technical data digital outputs</b>	
Number of outputs	4
Cable length, shielded	1000 m
Cable length, unshielded	600 m
Rated load voltage	DC 20.4...28.8 V
Current consumption from load voltage L+ (without load)	15 mA
Total current per group, horizontal configuration, 40°C	2 A
Total current per group, horizontal configuration, 60°C	-
Total current per group, vertical configuration	-
Output current at signal "1", rated value	0.5 A
Signal logic output	Sourcing output
Output delay of "0" to "1"	100 μs
Output delay of "1" to "0"	175 μs
Minimum load current	-

SDO 4xDC 24V 0.5A - Technical data

<b>Order no.</b>	<b>022-1SD10</b>
Lamp load	5 W
Parallel switching of outputs for redundant control of a load	not possible
Parallel switching of outputs for increased power	not possible
Actuation of digital input	✓
Switching frequency with resistive load	max. 50 Hz
Switching frequency with inductive load	max. 0.5 Hz
Switching frequency on lamp load	max. 10 Hz
Internal limitation of inductive shut-off voltage	L+ (-45 V)
Short-circuit protection of output	yes, electronic
Trigger level	1.7 A
Number of operating cycle of relay outputs	-
Switching capacity of contacts	-
Output data size	4 Bit
<b>Status information, alarms, diagnostics</b>	
Status display	green LED per channel
Interrupts	yes, parameterizable
Process alarm	no
Diagnostic interrupt	yes, parameterizable
Diagnostic functions	yes, parameterizable
Diagnostics information read-out	possible
Supply voltage display	green LED
Group error display	red SF LED
Channel error display	red ERR-LED and yellow ER2-LED
<b>Isolation</b>	
Between channels	-
Between channels of groups to	-
Between channels and backplane bus	✓
Insulation tested with	DC 500 V
<b>PWM data</b>	
PWM channels	-
PWM time basis	-
Period length	-
Minimum pulse width	-
Type of output	-
<b>Safety</b>	
Safety protocol	-

<b>Order no.</b>	<b>022-1SD10</b>
Safety requirements	SIL CL 3, PL e, Kat 4
Secure user address	1 - 4095
Watchdog	parameterizable 20ms - 65s
Two channels	Each 2 of 4 outputs switchable
Test pulse length	parameterizable 20ms - 65s
Circuit monitoring	✓
<b>Datasizes</b>	
Input bytes	6
Output bytes	6
Parameter bytes	16
Diagnostic bytes	20
<b>Housing</b>	
Material	PC / PPE GF10
Mounting	Profile rail 35 mm
<b>Mechanical data</b>	
Dimensions (WxHxD)	12.9 mm x 109 mm x 76.5 mm
Net weight	64 g
Weight including accessories	69 g
Gross weight	85 g
<b>Environmental conditions</b>	
Operating temperature	0 °C to 60 °C
Storage temperature	-25 °C to 70 °C
<b>Certifications</b>	
UL certification	in preparation
KC certification	in preparation

Response time > Error-free case

## 2.11 Response time

### General

The response times of the System SLIO safety modules are listed below. The response time of the safety modules is included in the calculation of the fail-safe system response time.

### Response time safety digital inputs

The response time specifies the time between a signal transition at the digital input and the reliable availability of the safety message frame on the backplane bus.

### Response time safety digital outputs

The response time specifies the interval between the receipt of a safety message from the backplane bus and the signal transition at the digital output.

### Maximum response time of the system

These response times are required for plant design. Hereby you can determine whether the maximum error tolerance time of a process is not exceeded. Here, the following cases are to be distinguished, which are described below:

- Error-free case
- Existing error
- Arbitrary run times at single errors

#### 2.11.1 Error-free case

In the error-free case, it is assumed that none of the time monitors are responding and the passage of a signal from the input terminal of a System SLIO safety IN to the output terminal of a System SLIO safety OUT is considered:

System SLIO  
 Safety SDI → Bus coupler → Field bus → EtherCAT master → Field bus → FSoE master  
 Safety SDO ← Bus coupler ← Field bus ← EtherCAT master ← Field bus ←

**Maximum expected response time in the case without errors**

$$T_{\max NF} = T_{I_{ST}} + T_{I_{WCDT}} + T_{I_{FSoESync}} + T_{I_{ECS}} + (2 \times T_{I_{BUS}}) + T_{I_{ECM\_ECAT}} + (2 \times T_{PLC}) + T_{I_{ECM\_ECAT}} + T_{I_{BUS}} + (4 \times T_{CL}) + T_{O_{BUS}} + T_{O_{ECM\_ECAT}} + (2 \times T_{PLC}) + T_{O_{ECM\_ECAT}} + (2 \times T_{O_{BUS}}) + T_{O_{ECS}} + T_{O_{WCDT}}$$

**Calculation  $T_{FSoESync}$  normal**

$$T_{FSoESync} = T_{I_{WCDT}} + T_{I_{ECS}} + T_{I_{BUS}} + T_{I_{ECM\_ECAT}} + T_{PLC} + T_{I_{ECM\_ECAT}} + T_{I_{BUS}} + T_{CL} + T_{I_{BUS}} + T_{I_{ECM\_ECAT}} + T_{PLC} + T_{I_{ECM\_ECAT}} + T_{I_{BUS}} + T_{I_{ECS}}$$

**Calculation  $T_{FSoESync}$  max.**

$$T_{FSoESync} = T_{I_{WCDT}} + T_{I_{ECS}} + (2 \times T_{I_{BUS}}) + T_{I_{ECM\_ECAT}} + (2 \times T_{PLC}) + T_{I_{ECM\_ECAT}} + T_{I_{BUS}} + (2 \times T_{CL}) + T_{I_{BUS}} + T_{I_{ECM\_ECAT}} + (2 \times T_{PLC}) + T_{I_{ECM\_ECAT}} + (2 \times T_{I_{BUS}}) + T_{I_{ECS}}$$

- $T_{\max NF}$  - Max. response time in the case without errors (**max No Fault**).
- $T_{I_{ST}}$  - Input smoothing time of the inputs of the System SLIO Safety SDI (**Smoothing Time**).
- $T_{I/TO_{WCDT}}$  - Max. response time in the case without errors (**Worst Case Delay Time**).
- $T_{I_{FSoESync}}$  - Synchronization of the FSoE slave stack with a new FSoE telegram to transfer the current state (**FailSafe over EtherCAT Synchronisation**).
- $T_{PLC}$  - PLC cycle time for copying the EtherCAT input/output data from Safety SDI to the FSoE master and back respectively between Safety SDO and FSoE master.
- $T_{I/TO_{ECS}}$  - Max. response time of the EtherCAT slave, i.e. max. delay due to the EtherCAT coupler and the backplane bus (**EtherCAT Slave**).
- $T_{I/TO_{BUS}}$  - Time for EtherCAT bus transfer.
- $T_{ECM\_ECAT}$  - Max. delay due to the EtherCAT master stack.
- $T_{CL}$  - Configured cycle time of the safety PLC. This also corresponds to the cycle of the FSoE master stack (**Cycle**).

**For plant design sensor and actuator run times are to be taken into account:**

$$T_{\max NFSA} = T_{\text{SensorDLY}} + T_{\max NF} + T_{\text{ActuatorDLY}}$$

↳ *Chap. 2.11.4 'Designations' page 64*

- $T_{\max NFSA}$  - Max. response time in the case without errors with sensor and actuator (**max No Fault Sensor Actuator**)
- $T_{\text{SensorDLY}}$  - Delay time of the sensor (**Sensor DeLaY**)
- $T_{\max NF}$  - Max. response time in the case without errors (**max No Fault**)
- $T_{\text{ActuatorDLY}}$  - Delay time of the actuator (**Actuator DeLaY**)

Response time &gt; Existing error

## 2.11.2 Existing error

### Possible single errors

In the presence of an error, it is assumed that a time monitoring responds and triggers the corresponding error response. Possible causes include errors in the system, incorrect runtime information in the documentation of the standard system or an extension of the runtime beyond the value used in the calculation by changing the configuration of the standard system. The total response time in the error-free case increases by the maximum duration of the possible single errors:

- Discrepancy error in System SLIO safety SDI. Here, the discrepancy time must also be taken into account: ( $T_{DIS}$ )
- A single error occurs in the System SLIO safety SDI. Here the possibly larger max. response time during an error ( $T_{OFDT}$ ) is to be considered with the max. response time in error-free case ( $T_{WCDT}$ ): ( $T_{OFDT} - T_{WCDT}$ )
- Once or permanent interrupted communication between System SLIO safety SDI and the safety PLC. Here the Sync Manager monitoring time of the System SLIO safety SDI and the configured cyclic time of the control must be considered: ( $T_{PSTO} + T_{CL}$ )
- Once or permanent interrupted communication between System SLIO safety SDO and the safety PLC or failure of the safety PLC. Here the Sync Manager monitoring time of the System SLIO safety SDO and acknowledge time of the System SLIO safety SDO must be considered: ( $T_{PSTO} + T_{DAT}$ )
- A single error occurs in the System SLIO safety SDO. Here the possibly larger max. response time during an error ( $T_{OFDT}$ ) is to be considered with the max. response time in error-free case ( $T_{WCDT}$ ): ( $T_{OFDT} - T_{WCDT}$ )

### Max. response time on error

$$T_{\max OF} = T_{\max NF} + \text{MAX}((T_{DIS}), (T_{OFDT} - T_{WCDT}), (T_{ECSMWD} + T_{CL}), (T_{ECSMWD} + T_{DAT}), (T_{OFDT} - T_{WCDT}))$$

☞ *Chap. 2.11.4 'Designations' page 64*

- $T_{\max OF}$  - Max. response time in the presence of an error (**max One Fault**)
- $T_{\max NF}$  - Max. response time in the case without errors (**max No Fault**)
- $T_{DIS}$  - With 2-channel evaluation discrepancy time, otherwise 0 (**DIS**crepancy)
- $T_{I}/T_{O_{OFDT}}$  - Max. response time in the presence of an error (**One Fault Delay Time**)
- $T_{I}/T_{O_{WCDT}}$  - Max. response time in the case without errors (**Worst Case Delay Time**)
- $T_{I}/T_{O_{ECSMWD}}$  - Configured EtherCAT Sync Manager monitoring time (**EtherCAT SM WatchDog**)
- $T_{CL}$  - Configured cycle time of the safety PLC (**CycLe**)
- $T_{O_{DAT}}$  - Max. acknowledgement time of the System SLIO safety modules (**Device Acknowledgement Time**)

**For plant design sensor and actuator run times are to be taken into account:**

$$T_{\max OFSA} = T_{\text{SensorDLY}} + T_{\max OF} + T_{\text{ActuatorDLY}}$$

☞ *Chap. 2.11.4 'Designations' page 64*

- $T_{\max OFSA}$  - Max. response time in the presence of an error with sensor and actuator (**max One Fault SensorActuator**)
- $T_{\text{SensorDLY}}$  - Delay time of the sensor (**Sensor DeLaY**)
- $T_{\max OF}$  - Max. response time in the presence of an error (**max One Fault**)
- $T_{\text{ActuatorDLY}}$  - Delay time of the actuator (**Actuator DeLaY**)

### 2.11.3 Arbitrary run times at single errors

#### Times to be considered

At arbitrary run times of the standard system in addition to an existing error, it is assumed that the values of all the relevant run times lie nearby the limit of the monitored times.

- The max processing time to and in the System SLIO safety SDI:  
( $T_{I_{ST}} + T_{I_{DIS}} + T_{I_{WCDT}} + T_{I_{ECSMWD}}$ )
- The smallest of the possible monitoring times, from this moment the defined behaviour of an error is:  
( $\text{MIN}(T_{I_{ECSMWD}}, T_{\text{maxCL}}, T_{O_{ECSMWD}})$ )
- The max. processing time to and in the System SLIO safety SDO:  
( $T_{O_{WCDT}} + T_{O_{ECSMWD}}$ )
- The possibly increased processing times in case of an error within the System SLIO safety modules, here but only the larger of them, because it is assumed that there is a single error:  
( $\text{MAX}((T_{I_{OFDT}} - T_{I_{WCDT}}), (T_{O_{OFDT}} - T_{O_{WCDT}}))$ )
- For the entire process chain a good EtherCAT telegram could be sent before to the System SLIO safety SDI or -SDO. Here the largest of the two timeouts must be considered:  
( $\text{MAX}(T_{I_{ECSMWD}}, T_{O_{ECSMWD}})$ )

**Max. response time at arbitrary run times at one error**

$$\begin{aligned}
 T_{\max RT} &= T_{I_{ST}} + T_{I_{DIS}} + T_{I_{WCDT}} + T_{I_{ECSMWD}} \\
 &+ \text{MIN}(T_{I_{ECSMWD}}, T_{\max CL}, T_{O_{ECSMWD}}) \\
 &+ T_{O_{WCDT}} + T_{O_{ECSMWD}} \\
 &+ \text{MAX}((T_{I_{OFDT}} - T_{I_{WCDT}}), (T_{O_{OFDT}} - T_{O_{WCDT}})) \\
 &+ \text{MAX}(T_{I_{ECSMWD}}, T_{O_{ECSMWD}})
 \end{aligned}$$

☞ Chap. 2.11.4 'Designations' page 64

- $T_{\max RT}$  - Max. response time in the presence of an error with max. runtime (**max RunTime**)
- $T_{\max CL}$  - Max. cycle monitoring time with which the safety PLC is called (**max Cycle**)
- $T_{I_{ST}}$  - Input smoothing time of the inputs of the System SLIO Safety SDI (**S**oothing **T**ime)
- $T_{I_{DIS}}$  - With 2-channel evaluation discrepancy time, otherwise 0 (**DIS**crepancy)
- $T_{I/O_{WCDT}}$  - Max. response time in the case without errors (**W**orst **C**ase **D**elay **T**ime)
- $T_{I/O_{ECSMWD}}$  - Configured EtherCAT Sync Manager monitoring time (**E**ther**C**AT **S**M **W**atch**D**og)
- $T_{I/O_{OFDT}}$  - Max. response time in the presence of an error (**O**ne **F**ault **D**elay **T**ime)

**For plant design sensor and actuator run times are to be taken into account:**

$$T_{\max RTSA} = T_{\text{SensorDLY}} + T_{\max RT} + T_{\text{ActuatorDLY}}$$

☞ Chap. 2.11.4 'Designations' page 64

- $T_{\max RTSA}$  - Max. response time in the presence of an error with max. runtime with sensor and actuator (**max RunTime Sensor Actuator**)
- $T_{\text{SensorDLY}}$  - Delay time of the sensor (**S**ensor **D**e**L**a**Y**)
- $T_{\max RT}$  - Max. response time in the presence of an error with max. runtime (**max RunTime**)
- $T_{\text{ActuatorDLY}}$  - Delay time of the actuator (**A**ctuator **D**e**L**a**Y**)

**2.11.4 Designations**

**Abbreviations sorted by components**

Component	Time <sup>1</sup>	Meaning	Where from
Sensor	$T_{\text{SensorDLY}}$	Delay time of the sensor ( <b>S</b> ensor <b>D</b> e <b>L</b> a <b>Y</b> ).	Documentation sensor
System SLIO Safety SDI	$T_{I_{ST}}$	Input smoothing time of the inputs of the System SLIO Safety SDI ( <b>S</b> oothing <b>T</b> ime).	Configuration of the System SLIO safety modules, adapted to the sensor used
System SLIO Safety SDI	$T_{I_{DIS}}$	With 2-channel evaluation discrepancy time, otherwise 0 ( <b>DIS</b> crepancy).	Configuration of the System SLIO safety modules, adapted to the sensor used



Component	Time <sup>1</sup>	Meaning	Where from
System SLIO Safety SDI Safety SDO	$T_{I_{WCDT}}$ $T_{O_{WCDT}}$	Max. response time in the case without errors ( <b>W</b> orst <b>C</b> ase <b>D</b> elay <b>T</b> ime).	11ms
System SLIO Safety SDI Safety SDO	$T_{I_{OFDT}}$ $T_{O_{OFDT}}$	Max. response time in the presence of an error ( <b>O</b> ne <b>F</b> ault <b>D</b> elay <b>T</b> ime).	11ms
System SLIO Safety SDI Safety SDO	$T_{I_{DAT}}$ $T_{O_{DAT}}$	Max. acknowledgement time of the System SLIO safety modules ( <b>D</b> evice <b>A</b> cknowledgement <b>T</b> ime).	8ms
System SLIO Safety SDI Safety SDO	$T_{I_{ECSMWD}}$ $T_{O_{ECSMWD}}$	Configured EtherCAT Sync Manager monitoring time ( <b>E</b> ther <b>C</b> AT <b>S</b> M <b>W</b> atch <b>D</b> og).	<i>SPEED7 EtherCAT Manager</i> You can specify this time via the 'Advanced configurations' of the slave station with the parameter 'Set SM Watchdog' in the parameter group 'Readjusting Watchdog'. The default value is 100ms if nothing is set.
EtherCAT slave system	$T_{I_{ECS}}$ $T_{O_{ECS}}$	Max. response time of the EtherCAT slave, i.e. max. delay due to the EtherCAT coupler and the backplane bus. ( <b>E</b> ther <b>C</b> AT <b>S</b> lave).	Documentation of the EtherCAT bus coupler
EtherCAT master	$T_{I_{ECM\_ECAT}}$ $T_{O_{ECM\_ECAT}}$	Max. delay due to the EtherCAT Master stack.	Documentation of the EtherCAT master If exists, otherwise you can preset the EtherCAT cycle time as maximum value.
EtherCAT field bus	$T_{I_{Bus}}$ $T_{O_{Bus}}$	Time for EtherCAT bus transfer.	<i>SPEED7 EtherCAT Manager</i> If exists, otherwise you can preset the EtherCAT cycle time as maximum value.
Safety PLC	$T_{CL}$	Configured cycle time of the safety PLC. This also corresponds to the cycle of the FSoE master stack ( <b>C</b> yc <b>L</b> e).	Configured time (cycle time) of the call within the safety PLC. The time interval between the start times can be extended by processing higher-priority interrupts, by communication load or by test and commissioning functions. You can determine the influence of these factors yourself based on the documentation and configuration of the standard system and then add them to the value determined here.
Safety PLC	$T_{maxCL}$	Max. cycle monitoring time with which the safety PLC is called ( <b>max</b> <b>C</b> yc <b>L</b> e).	Configured monitoring time of the safety PLC

## Compatibility list

Component	Time <sup>1</sup>	Meaning	Where from
Safety PLC	$T_{\text{PLC}}$	Configured PLC cycle time for copying the EtherCAT input/output data from Safety SDI to the FSoE master and back respectively between Safety SDO and FSoE master.	Documentation PLC with EtherCAT master
FSoE master	$T_{\text{FSoESync}}$	Synchronization of the FSoE slave stack with a new FSoE telegram to transfer the current state ( <b>FailSafe over EtherCAT Synchronisation</b> ).	Cycle time of the FSoE master
Actuator	$T_{\text{ActuatorDLY}}$	Delay time of the actuator ( <b>Actuator DeLaY</b> ).	Documentation of the actuator
Total Input to output	$T_{\text{maxNF}}$	Max. response time in the case without errors ( <b>max No Fault</b> ).	See formula ↗ <i>Chap. 2.11.1 'Error-free case' page 60</i>
Total Sensor to actuator	$T_{\text{maxNFSA}}$	Max. response time in the case without errors with sensor and actuator ( <b>max No Fault Sensor Actuator</b> ).	See formula ↗ <i>Chap. 2.11.1 'Error-free case' page 60</i>
Total Input to output	$T_{\text{maxOF}}$	Max. response time in the presence of an error ( <b>max One Fault</b> ).	See formula ↗ <i>Chap. 2.11.2 'Existing error' page 62</i>
Total Sensor to actuator	$T_{\text{maxOFSA}}$	Max. response time in the presence of an error with sensor and actuator ( <b>max One Fault SensorActuator</b> ).	See formula ↗ <i>Chap. 2.11.2 'Existing error' page 62</i>
Total Input to output	$T_{\text{maxRT}}$	Max. response time in the presence of an error with max. runtime ( <b>max RunTime</b> ).	See formula ↗ <i>Chap. 2.11.3 'Arbitrary run times at single errors' page 63</i>
Total Sensor to actuator	$T_{\text{maxRTSA}}$	Max. response time in the presence of an error with max. runtime with sensor and actuator ( <b>max RunTime Sensor Actuator</b> ).	See formula ↗ <i>Chap. 2.11.3 'Arbitrary run times at single errors' page 63</i>
Total Sensor to actuator	$T_{\text{PSTO}}$	Configured safety monitoring time ( <i>FSoE_WD_Time</i> ).	See formula ↗ <i>Chap. 2.5.2 'FSoE communication parameters' page 41</i>

1) "I" or "O" after the "T" represent input or output.

## 2.12 Compatibility list

### Sensors

The System SLIO safety input module was successfully tested with the following sensors:

- SICK L41S-11MA1A Single-beam photoelectric safety switch
- SICK ES21-SA10E1 Emergency stop pushbutton
- SICK i10-PA213 Safety position switch
- SICK miniTwin4 Safety light curtain
- SICK T4000-E0101K Safety switch

**Actuators**

The System SLIO safety output module was successfully tested with the following actuators:

- Pilz Safety switch device PNOZ X2.7P



*You can also use sensors and actuators from other producers, which have the properties suitable for the application and the corresponding type examination.*

**Controllers**

The System SLIO safety input and output modules were successfully tested with the following controllers:

- System SLIO CPU 015N
- SIS 800 FSoE-Master from ISH Ingenieursozietät GmbH

## 3 Deployment

### 3.1 Planning of a safety-related control system

#### General

In the planning phase the complete definition of the safety function(s) takes place. Besides the risk evaluation the planning contains the detailed definition of all system components, the definition of the system parameters, the detailed installation and wiring of the components.

**DANGER!**

A careful executed planning serves for avoidance of errors. Errors in safety-related machines can lead to irreversible injuries and to death.

**CAUTION!**

In the phase of planning the "Check list planning" is to be used.  
↳ *Appendix A 'Checklist planning' page 135*

#### Risk evaluation

The risk evaluation shows the risk, which can come from a machine and which plant components must be equipped with safety equipment. Due to the safety measures the residual risk is reduced to an acceptable level.

**CAUTION!**

As a manufacturer of machine you are obliged under the machinery directive to execute a risk evaluation to identify all hazards associated with the machine and reduce the residual risk to an acceptable minimum.

**CAUTION!**

The risk evaluation must necessarily be conducted in the planning phase and before realization and conversion works.

Sequence of a risk evaluation in accordance to DIN EN ISO 12100-1 and EN ISO 14121

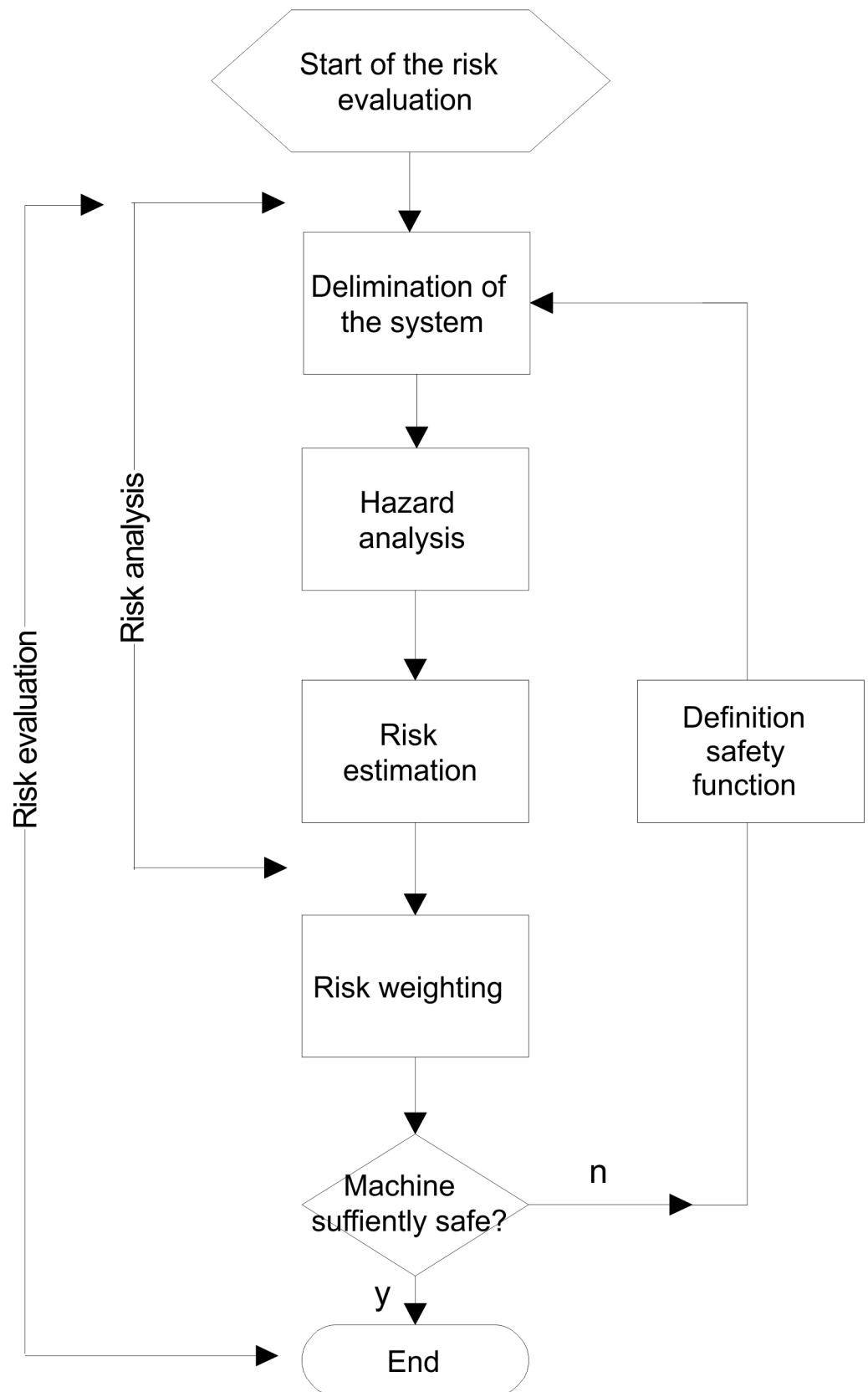

**Installation and wiring diagram**

In the phase of planning an installation and a wiring diagram for the total safety system are to be created. It contains all system components and their wiring.

**CAUTION!**

Please consider a separation of voltage ranges higher than extra-low voltage in the installation and wiring diagram for the exclusion of cross- or short circuits to potentials > 60V.

This can be achieved for the System SLIO by a separate installation and appropriate isolation.

With the production of the wiring diagram valid standards and guidelines are to be considered for the proper installation of lines.

**Determining the device parameters**

The available safety parameters can be found in the chapter "Product description" [↪ Chap. 2 'Product description' page 22.](#)

The parameters of further standard modules can be found in the according user manual.

**CAUTION!**

In the phase of planning a list of parameters to be adjusted is to be created with a determination of the individual parameters and their verification.

**Sequence of the phase of planning**

The system is planned according to the respective need of the plant or machine. The components available for the control technology are more described at "Installation" further down. Before the commissioning of a module the following must be checked and ensured:

- Compatibility of the modules ( [↪ Chap. 2.12 'Compatibility list' page 66](#) and technical data).
- Sufficient supply of the control system by attached power supplies, respectively attached safety components.

**3.2 Industrial security in information technology****Latest version**

This chapter can also be found as a guide '*Industrial IT Security*' at [www.yaskawa.eu.com](http://www.yaskawa.eu.com)

**Hazards**

The topic of data security and access protection has become increasingly important in the industrial environment. The increased networking of entire industrial systems to the network levels within the company together with the functions of remote maintenance have all served to increase vulnerability. Hazards can arise from:

- Internal manipulation such as technical errors, operating and program errors and deliberate program or data manipulation.
- External manipulation such as software viruses, worms and Trojans.
- Human carelessness such as password phishing.

**Precautions**

The most important precautions to prevent manipulation and loss of data security in the industrial environment are:

- Encrypting the data traffic by means of certificates.
- Filtering and inspection of the traffic by means of VPN - "Virtual Private Networks".
- Identification of the user by "Authentication" via safe channels.

- Segmenting in protected automation cells, so that only devices in the same group can exchange data.
- Deactivation of unnecessary hardware and software.

### Further Information

You can find more information about the measures on the following websites:

- Federal Office for Information Technology [www.bsi.bund.de](http://www.bsi.bund.de)
- Cybersecurity & Infrastructure Security Agency [us-cert.cisa.gov](http://us-cert.cisa.gov)
- VDI / VDE Society for Measurement and Automation Technology [www.vdi.de](http://www.vdi.de)

## 3.2.1 Protection of hardware and applications

### Precautions

- Do not integrate any components or systems into public networks.
  - Use VPN "Virtual Private Networks" for use in public networks. This allows you to control and filter the data traffic accordingly.
- Always keep your system up-to-date.
  - Always use the latest firmware version for all devices.
  - Update your user software regularly.
- Protect your systems with a firewall.
  - The firewall protects your infrastructure internally and externally.
  - This allows you to segment your network and isolate entire areas.
- Secure access to your plants via user accounts.
  - If possible, use a central user management system.
  - Create a user account for each user for whom authorization is essential.
  - Always keep user accounts up-to-date and deactivate unused user accounts.
- Secure access to your plants via secure passwords.
  - Change the password of a standard login after the first start.
  - Use strong passwords consisting of upper/lower case, numbers and special characters. The use of a password generator or manager is recommended.
  - Change the passwords according to the rules and guidelines that apply to your application.
- Deactivate inactive communication ports respectively protocols.
  - Only the communication ports that are used for communication should be activated.
  - Only the communication protocols that are used for communication should be activated.
- Consider possible defence strategies when planning and securing the system.
  - The isolation of components alone is not sufficient for comprehensive protection. An overall concept is to be drawn up here, which also provides defensive measures in the event of a cyber attack.
  - Periodically carry out threat assessments. Among others, a comparison is made here between the protective measures taken and those required.
- Limit the use of external storage media.
  - Via external storage media such as USB memory sticks or SD memory cards, malware can get directly into a system while bypassing a firewall.
  - External storage media or their slots must be protected against unauthorized physical access, e.g. by using a lockable control cabinet.
  - Make sure that only authorized persons have access.
  - When disposing of storage media, make sure that they are safely destroyed.
- Use secure access paths such as HTTPS or VPN for remote access to your plant.
- Enable security-related event logging in accordance with the applicable security policy and legal requirements for data protection.

### 3.2.2 Protection of PC-based software

#### Precautions

Since PC-based software is used for programming, configuration and monitoring, it can also be used to manipulate entire systems or individual components. Particular caution is required here!

- Use user accounts on your PC systems.
  - If possible, use a central user management system.
  - Create a user account for each user for whom authorization is essential.
  - Always keep user accounts up-to-date and deactivate unused user accounts.
- Protect your PC systems with secure passwords.
  - Change the password of a standard login after the first start.
  - Use strong passwords consisting of upper/lower case, numbers and special characters. The use of a password generator or manager is recommended.
  - Change the passwords according to the rules and guidelines that apply to your application.
- Enable security-related event logging in accordance with the applicable security policy and legal requirements for data protection.
- Protect your PC systems by security software.
  - Install virus scanners on your PC systems to identify viruses, trojans and other malware.
  - Install software that can detect phishing attacks and actively prevent them.
- Always keep your software up-to-date.
  - Update your operating system regularly.
  - Update your software regularly.
- Make regular backups and store the media at a safe place.
- Regularly restart your PC systems. Only boot from storage media that are protected against manipulation.
- Use encryption systems on your storage media.
- Perform security assessments regularly to reduce the risk of manipulation.
- Use only data and software from approved sources.
- Uninstall software which is not used.
- Disable unused services.
- Activate a password-protected screen lock on your PC systems.
- Always lock your PC systems as soon as you leave your PC workstation.
- Do not click any links that come from unknown sources. If necessary ask, e.g. on e-mails.
- Use secure access paths such as HTTPS or VPN for remote access to your PC system.

### 3.3 Installation guidelines

#### General

The installation guidelines contain information about the interference free deployment of the System SLIO. There is the description of the ways, interference may occur in your PLC, how you can make sure the electromagnetic compatibility (EMC), and how you manage the isolation.

#### What does EMC mean?

Electromagnetic compatibility (EMC) means the ability of an electrical device, to function error free in an electromagnetic environment without being interfered respectively without interfering the environment.

All System SLIO components are developed for the deployment in industrial environments and meets high demands on the EMC. Nevertheless you should project an EMC planning before installing the components and take conceivable interference causes into account.



**Possible interference causes**

Electromagnetic interferences may interfere your control via different ways:

- Electromagnetic fields (RF coupling)
- Magnetic fields with power frequency
- Bus system
- Power supply
- Protected earth conductor

Depending on the spreading medium (lead bound or lead free) and the distance to the interference cause, interferences to your control occur by means of different coupling mechanisms.

There are:

- galvanic coupling
- capacitive coupling
- inductive coupling
- radiant coupling

**Basic rules for EMC**

In the most times it is enough to take care of some elementary rules to guarantee the EMC. Please regard the following basic rules when installing your PLC.

- Take care of a correct area-wide grounding of the inactive metal parts when installing your components.
  - Install a central connection between the ground and the protected earth conductor system.
  - Connect all inactive metal extensive and impedance-low.
  - Please try not to use aluminium parts. Aluminium is easily oxidizing and is therefore less suitable for grounding.
- When cabling, take care of the correct line routing.
  - Organize your cabling in line groups (high voltage, current supply, signal and data lines).
  - Always lay your high voltage lines and signal respectively data lines in separate channels or bundles.
  - Route the signal and data lines as near as possible beside ground areas (e.g. suspension bars, metal rails, tin cabinet).
- Proof the correct fixing of the lead isolation. ↪ *'Isolation of conductors' page 74*
  - Data lines must be laid isolated.
  - Analog lines must be laid isolated. When transmitting signals with small amplitudes the one sided laying of the isolation may be favourable.
  - Lay the line isolation extensively on an isolation/protected earth conductor rail directly after the cabinet entry and fix the isolation with cable clamps.
  - Make sure that the isolation/protected earth conductor rail is connected impedance-low with the cabinet.
  - Use metallic or metallised plug cases for isolated data lines.
- In special use cases you should appoint special EMC actions.
  - Consider to wire all inductivities with erase links.
  - For lightening cabinets you should avoid luminescent lamps.
- Create a homogeneous reference potential and ground all electrical operating supplies when possible.
  - Please take care for the targeted employment of the grounding actions. The grounding of the PLC serves for protection and functionality activity.
  - Connect installation parts and cabinets with the System SLIO in star topology with the isolation/protected earth conductor system. So you avoid ground loops.
  - If there are potential differences between installation parts and cabinets, lay sufficiently dimensioned potential compensation lines.

**Isolation of conductors**

Electrical, magnetically and electromagnetic interference fields are weakened by means of an isolation, one talks of absorption. Via the isolation rail, that is connected conductive with the rack, interference currents are shunt via cable isolation to the ground. Here you have to make sure, that the connection to the protected earth conductor is impedance-low, because otherwise the interference currents may appear as interference cause.

When isolating cables you have to regard the following:

- If possible, use only cables with isolation tangle.
- The hiding power of the isolation should be higher than 80%.
- Normally you should always lay the isolation of cables on both sides. Only by means of the both-sided connection of the isolation you achieve high quality interference suppression in the higher frequency area. Only as exception you may also lay the isolation one-sided. Then you only achieve the absorption of the lower frequencies. A one-sided isolation connection may be convenient, if:
  - the conduction of a potential compensating line is not possible.
  - analog signals (some mV respectively  $\mu\text{A}$ ) are transferred.
  - foil isolations (static isolations) are used.
- With data lines always use metallic or metallised plugs for serial couplings. Fix the isolation of the data line at the plug rack. Do not lay the isolation on the PIN 1 of the plug bar!
- At stationary operation it is convenient to strip the insulated cable interruption free and lay it on the isolation/protected earth conductor line.
- To fix the isolation tangles use cable clamps out of metal. The clamps must clasp the isolation extensively and have well contact.
- Lay the isolation on an isolation rail directly after the entry of the cable in the cabinet. Lead the isolation further on to the System SLIO module and don't lay it on there again!

**CAUTION!****Please regard at installation!**

At potential differences between the grounding points, there may be a compensation current via the isolation connected at both sides.

Remedy: Potential compensation line

### 3.4 Setting the F-address

#### Address switch for F-address

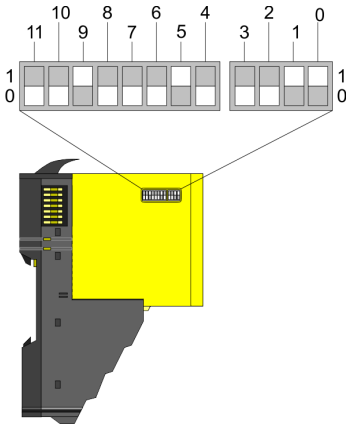

The F-address respectively "Secure user address" is to be configured by the F-address switch at the safety module and additionally in the master system e.g. hardware configurator. The F-address is to be set by the F-address switch besides on the safety module. Only if the F-address set in the hardware configurator accords to the setting of the F-address switch, it is possible to operate!

Pos	Value	Example	
		State	Address
0	1	1	$1+2+32+512=547$ Address: 547
1	2	1	
2	4	0	
3	8	0	
4	16	0	
5	32	1	
6	64	0	
7	128	0	
8	256	0	
9	512	1	
10	1024	0	
11	2048	0	



**When the safety module is installed, the F-address switch may not be accessed!**

To set the F-address on the safety module the (electronic) module is to be demounted before as described at "Demounting and module exchange". ↪ Chap. 3.6 'Demounting and module exchange' page 84

- **Before setting take the field bus coupler of circuit!**
- **F-address must be unique!**
  - F-addresses from 1 to 4095 may be set.
  - Each F-address must be unique in the communication network of the safety PLC!
- **Only use suitable tools for the setting!**
  - The switching elements of the F-address switch must be set only with a suitable tool like a screwdriver or a clockmaker.
  - In no case should pressure be exerted on the switching elements.
- **Setting the F-address via safety parameter dialog**
  - In addition the F-address setting of the F-address switch must be configured by the safety parameter dialog of the master system.

### 3.4.1 Changing the F-address

The following 2 steps are required to change the F-address:

- Changing an existing F-address at the module
- Changing the F-address in the configuration



*For this please consider the hints below at "Demounting and module exchange". ↪ Chap. 3.6 'Demounting and module exchange' page 84*

#### 3.4.1.1 Changing an existing F-address at the module

If you want to change the F-address of a System SLIO safety module, which just operates with a valid configuration, there are the following options to initiate the change process:

- At the module by means of the F-address switch
- Online via the configuration tool of the FSoE master

##### **At the module by means of the F-address switch**

With the following approach the System SLIO safety module is to be powered off and to demounted.

1. ➤ Switch off the DC 24V power supply of your System SLIO safety module.
2. ➤ Demount the System SLIO safety module.
3. ➤ Switch all the switches of the F-address switch to 0 position.
4. ➤ Mount the System SLIO safety module.
5. ➤ Switch on the DC 24V power supply for the System SLIO safety module.
6. ➤ Please wait for about 5s and switch the DC 24V power supply for the System SLIO safety module off again. Hereby the internal F-address memory of the System SLIO safety module is cleared.
7. ➤ Demount the System SLIO safety module.
8. ➤ Switch the F-address switch to the wished F-address.
9. ➤ Mount the System SLIO safety module.
10. ➤ Switch on the DC 24V power supply for the System SLIO safety module again.

**Online via the configuration tool of the FSoE master**

With the following approach the System SLIO safety module is to be powered off and to demounted.

1. ➤ Switch off the DC 24V power supply of your System SLIO safety module.
2. ➤ Demount the System SLIO safety module.
3. ➤ Switch the F-address switch to the wished F-address.
4. ➤ Mount the System SLIO safety module.
5. ➤ Switch on the DC 24V power supply for the System SLIO safety module again.
6. ➤ Start the configuration tool of the FSoE master, open the properties dialog of the safety module and set the *reparametrization mode*. For details, refer to the manual for your FSoE master.
7. ➤ Wait 5s.
8. ➤ Start the configuration tool of the FSoE master, open the properties dialog of the safety module and reset the *reparametrization mode* again. For details, refer to the manual for your FSoE master.
9. ➤ Transfer the safety configuration to the FSoE master and restart the system.

**3.4.1.2 Changing the F-address in the configuration**

For details, refer to the manual for your FSoE master.

**CAUTION!**

- Once the F-address has been changed, a complete functional test including verification and validation of the system must be performed. This must be documented accordingly.
- Proceed accordingly carefully with the function test, since you must expect faulty behaviour of the machine or system after changing the F-address.

## 3.5 Mounting



### CAUTION!

In the phase of installation the "Check list Installation" of the appendix is to be used. ↪ *Appendix B 'Checklist installation' page 136*

- Make sure that the installation is complete in accordance with the installation and wiring plan.
- Make sure that you bring a supply voltage separation in the wiring in accordance to SELV / PELV.
- After the installation make a visual inspection and check all components for visible damages.
- Check the system for wiring errors.
- Check the tensile strength of the electrical terminal and screw connections.
- Ensure the installation and wiring in accordance to valid standards and guidelines.
- Make sure that the environmental characteristics of the system, which are described in chapter 2, are not exceeded. ↪ *Chap. 2.6 'SDI 4xDC 24V - Technical data' page 42*, ↪ *Chap. 2.10 'SDO 4xDC 24V 0.5A - Technical data' page 57*
- Make sure that the type of safety system is sufficient.
- Make sure that the safety system will not be damaged by moving parts or working in the environment of the installed safety components.
- Make sure that the system components do not get in contact to aggressive media (e.g. acid, leaches, gear oil).

### 3.5.1 Requirements to the operating personnel

Qualified personnel are persons who, based on their education, experiences, instructions about valid standards and regulations, accident prevention regulations and operation conditions, are authorized by the plant safety executive manager to execute the required actions and to recognize and avoid potential hazards. The required qualifications for this duty are e.g.:

- Training or instruction in accordance with the standards of the safety engineering in care and use of appropriate safety equipment.



### DANGER!

#### Risk of life by electrical current!

Devices and the environment in the switch gear cabinet can remain at dangerous potentials.

- For this before you start with work make sure that the device and the environment are off circuit.
- Observe the relevant safety regulations when handling with high-voltage devices.
- Make sure that only qualified personnel installs this module.

### 3.5.2 Functional principle

There is a locking lever at the top side of the terminal module. For mounting and demounting this locking lever is to be turned upwards until this engages audible. For mounting plug the module to the module installed before and push the module to the mounting rail guided by the strips at the upper and lower side of the module. The module is fixed to the mounting rail by pushing downward the locking lever. The modules may either separately be mounted to the mounting rail or as block. Here is to be considered that each locking lever is opened.

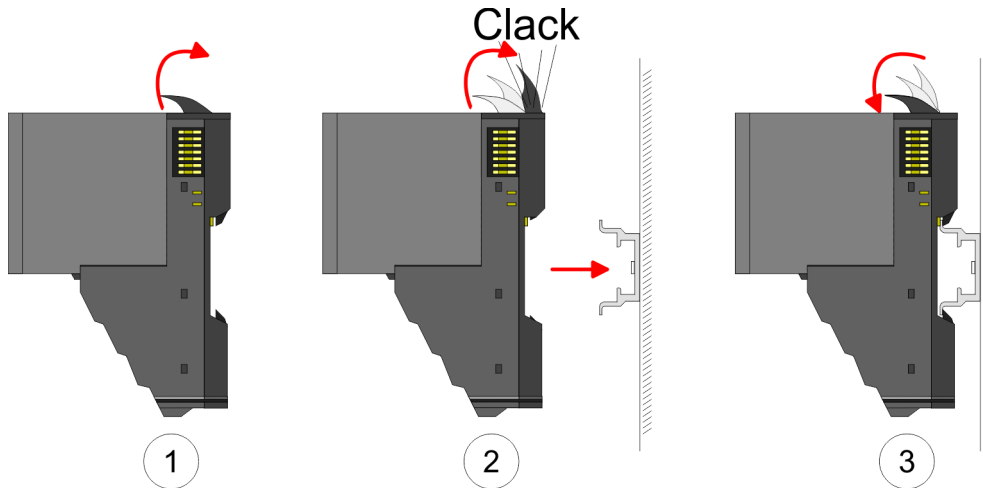

For the exchange of a electronic module, the electronic module may be pulled forward after pressing the unlocking lever at the lower side of the module. For installation plug the electronic module guided by the strips at the lower side until this engages audible to the terminal module.

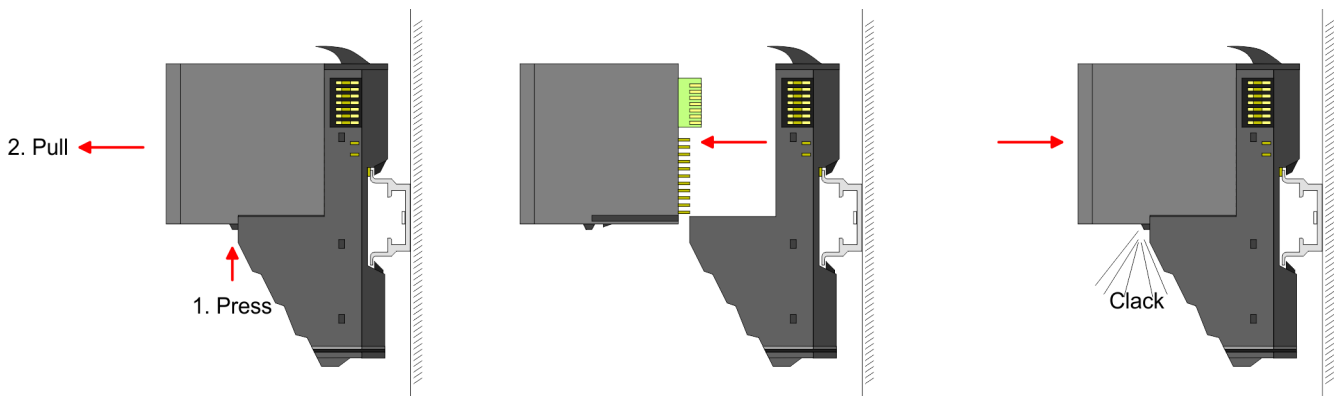

### 3.5.3 Mounting Proceeding

The modules were directly be mounted to the mounting rail and so connected to the backplane bus and the power supply for the electronic and power section. Up to 64 modules may be mounted. Please consider here that the sum current of the electronic power supply does not exceed the maximum value of 3A. By means of the power module 007-1AB10 the current of the electronic power supply may be expanded with 2A. More about this may be found at "Wiring". ↪ *Chap. 3.7 'Wiring' page 88*

**Possibilities**

Horizontal hanging or lying

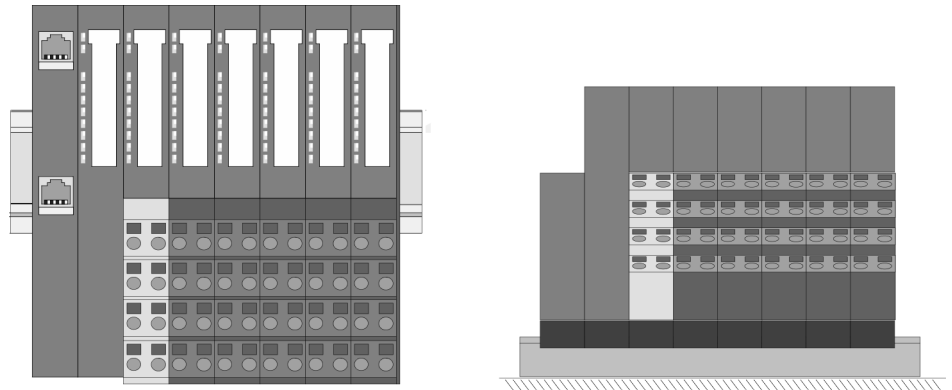

**Mounting mounting rail**

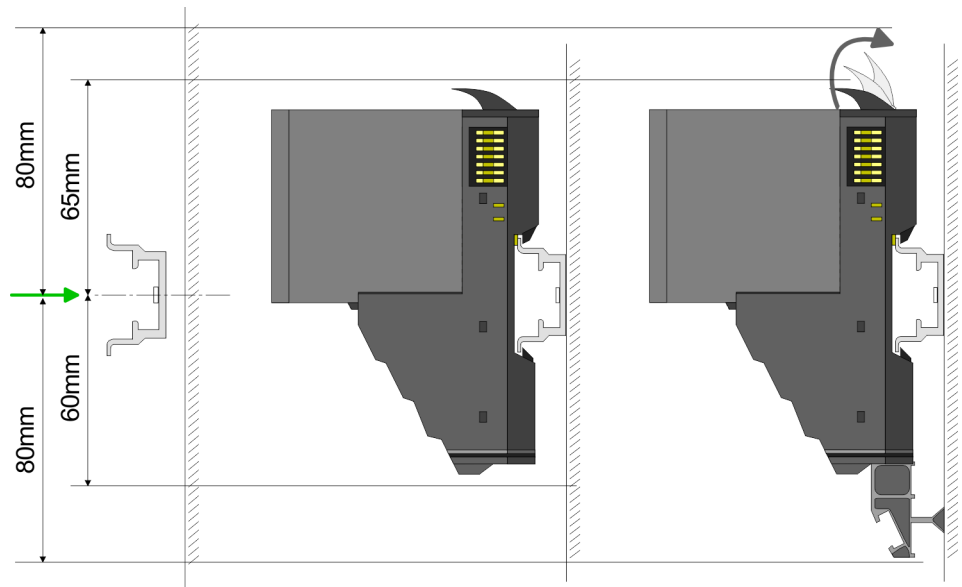

➔ Mount the mounting rail! Please consider that a clearance from the middle of the mounting rail of at least 80mm above and 60mm below, respectively 80mm by deployment of shield bus carriers, exist.



### Mounting head module (e.g. bus coupler)

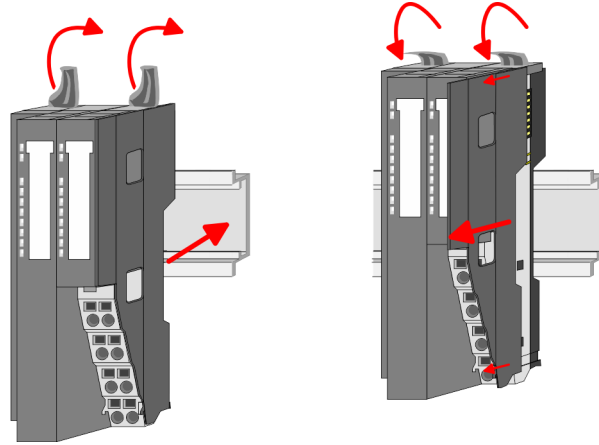

1. → Start at the left side with the head module (e.g. bus coupler). For this turn both locking lever upwards, put the head module to the mounting rail and turn both locking lever downward.
2. → Before mounting the periphery modules you have to remove the bus cover at the right side of the Head module by pulling it forward. Keep the cover for later mounting.

### Mounting periphery modules

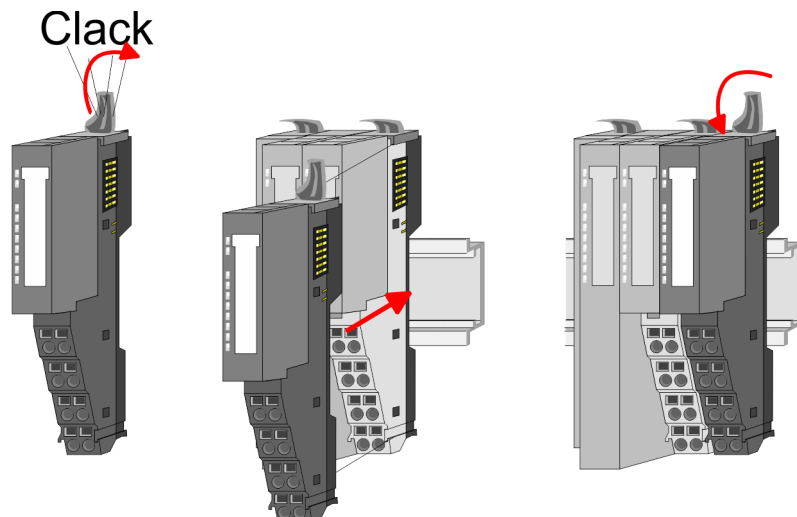

- Mount the periphery modules you want.

**Characteristics when installing System SLIO safety modules**

- Please consider when planning with System SLIO safety modules that you may not install a System SLIO safety module before and or behind System SLIO clamp modules!

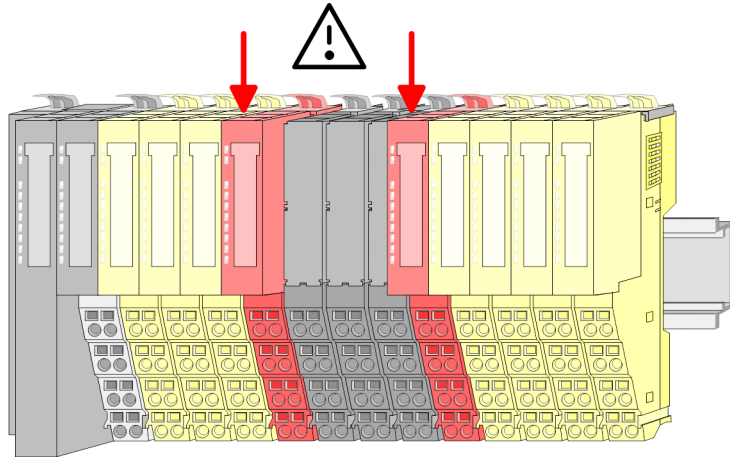

- Please consider when planning with System SLIO safety modules that you may not install a System SLIO safety module behind a slave extension module of the System SLIO line extension!

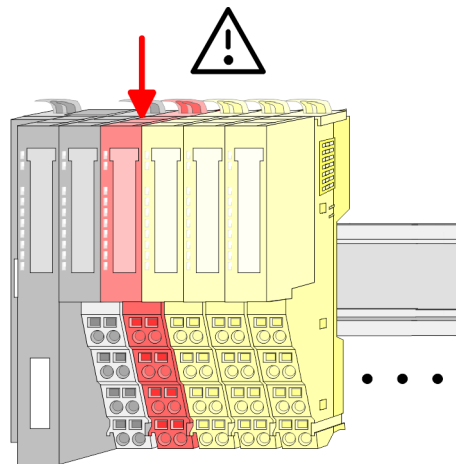

**Mounting the bus cover at a peripheral module**

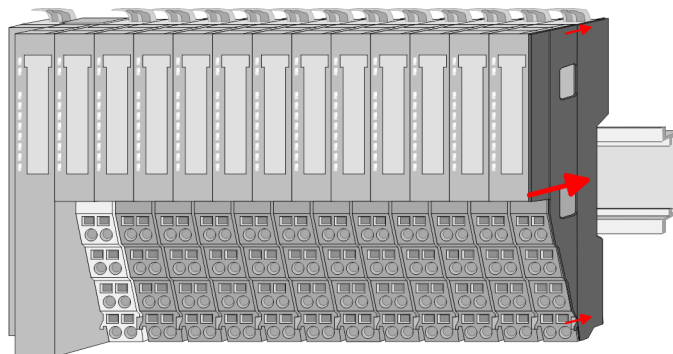

- ➔ After mounting the whole system, to protect the backplane bus connectors at the last module you have to mount the bus cover, now.

### Mounting the bus cover at a clamp module

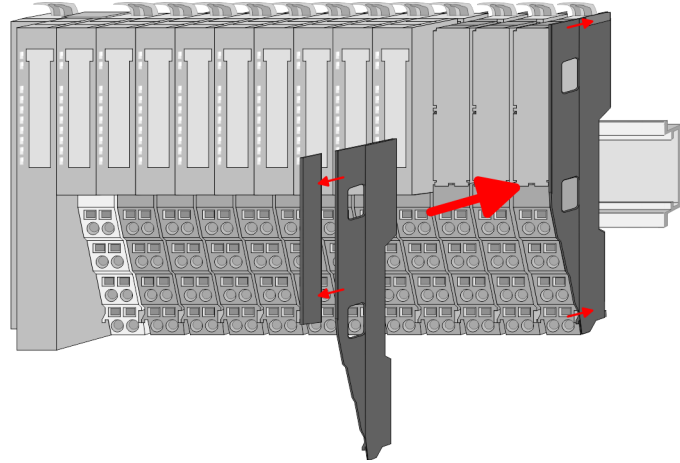

- If the last module is a clamp module, for adaptation the upper part of the bus cover is to be removed.

### Mounting shield bus carrier

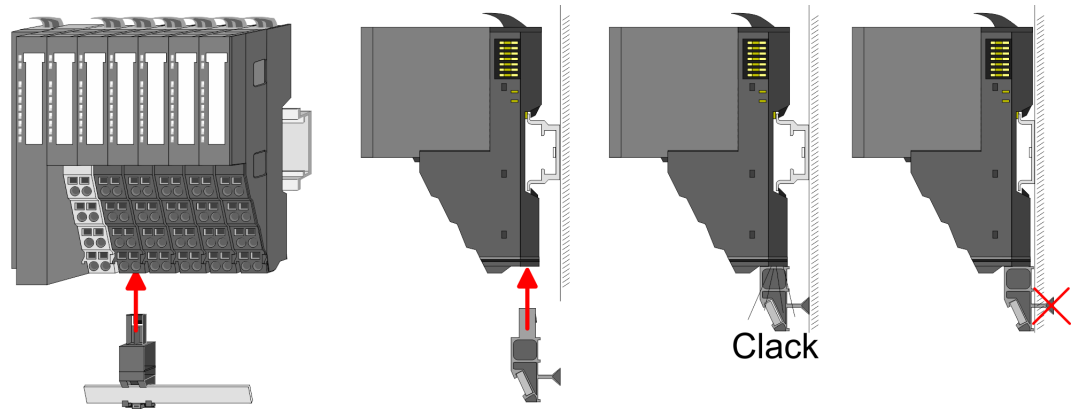

- The shield bus carrier (available as accessory) serves to carry the shield bus to connect cable shields. The shield bus carrier is mounted underneath the terminal of the terminal module. With a flat mounting rail for adaptation to a flat mounting rail you may remove the spacer of the shield bus carrier.

### 3.6 Demounting and module exchange

**A defective module must be replaced immediately.**



#### CAUTION!

- Demounting respectively module exchange may be performed only by authorized and qualified personnel.
- A defective System SLIO safety module may only be replaced by a System SLIO safety module with the same order number respectively by a module of the compatibility list, which is under construction.
- After the module exchange a complete function test inclusive verification and validation for the system must be accomplished. This should accordingly be documented.
- Proceed with the function test accordingly carefully, since you may reckon that after the module exchange there is an incorrect behavior of the machine respectively plant.
- Defective modules must be labelled as defective and should be sent back to Yaskawa. A re-use is absolutely prevented by measures within the quality management with the user.

#### 3.6.1 Proceeding

With demounting and exchange of a module, head module (e.g. bus coupler) or a group of modules for mounting reasons you have always to remove the electronic module of the just mounted right module. After the mounting it may be plugged again.

##### Exchange of an electronic module

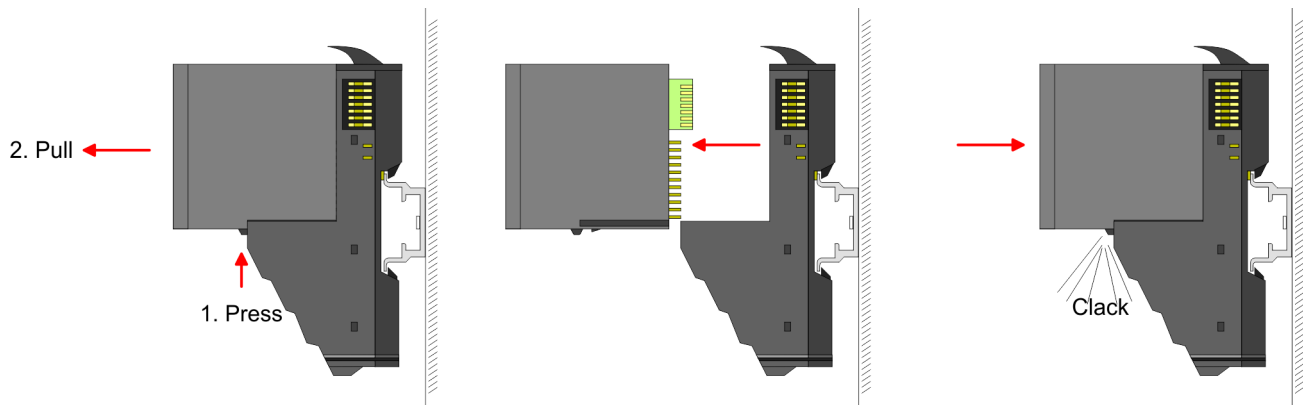

- 1.** For the exchange of an electronic module, the electronic module may be pulled forward after pressing the unlocking lever at the lower side of the module.
- 2.** To exchange a System SLIO safety module read the F-address of the address switch of the module to be changed and take these settings for the replacement module.
- 3.** For installation plug the electronic module guided by the strips at the lower side until this engages audible to the terminal module.

**Exchange of a module**

1. ➤ Remove if exists the wiring at the module ↪ *Chap. 3.7 'Wiring' page 88.*

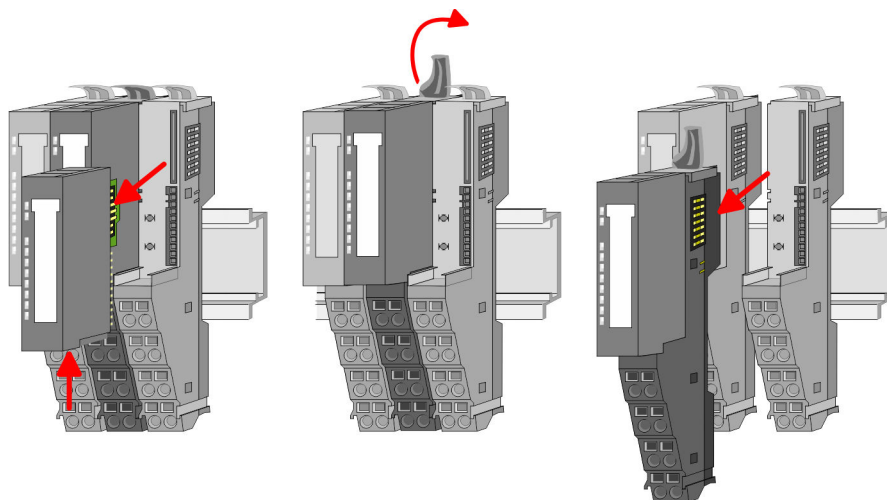

2. ➤ Press the unlocking lever at the lower side of the just mounted right module and pull it forward.
3. ➤ Turn the locking lever of the module to be exchanged upwards.
4. ➤ Pull the module forward.

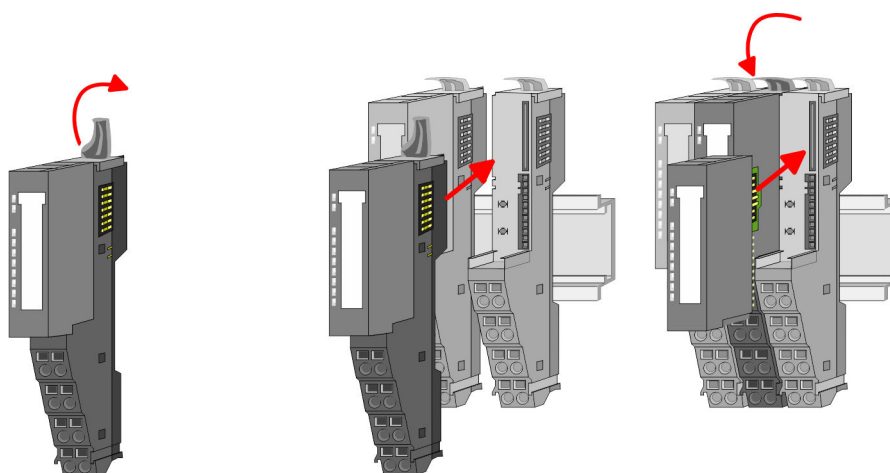

5. ➤ For mounting turn the locking lever of the module to be mounted upwards.
6. ➤ To mount the module put it to the gap between the both modules and push it, guided by the stripes at both sides, to the mounting rail.
7. ➤ Turn the locking lever downward again.
8. ➤ Plug again the electronic module, which you have removed before.

**Exchange of a head module (e.g. bus coupler)****CAUTION!**

Bus interface and power module of a head module may not be separated!  
Here you may only exchange the electronic module!

1. ➤ Remove if exists the wiring of the head module. ↪ *Chap. 3.7 'Wiring' page 88.*

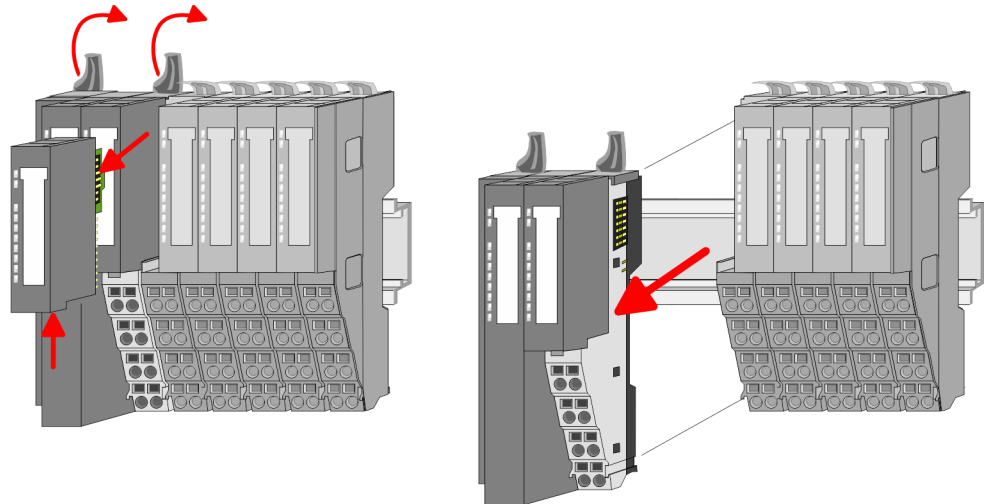

2. ➤ Press the unlocking lever at the lower side of the just mounted right module and pull it forward.  
3. ➤ Turn all the locking lever of the head module to be exchanged upwards.  
4. ➤ Pull the head module forward.

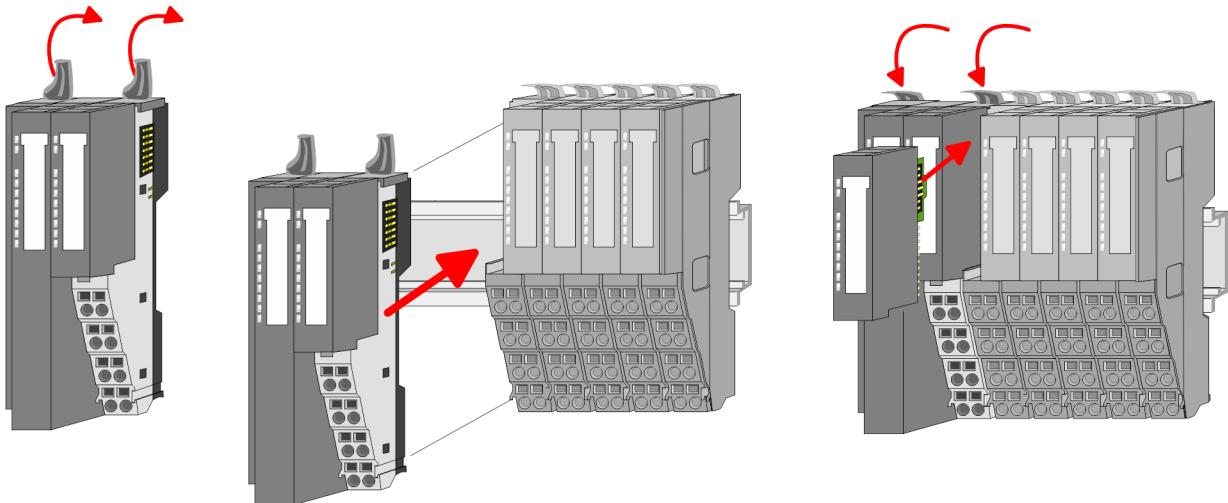

5. ➤ For mounting turn all the locking lever of the head module to be mounted upwards.  
6. ➤ To mount the head module put it to the left module and push it, guided by the stripes, to the mounting rail.  
7. ➤ Turn all the locking lever downward again.  
8. ➤ Plug again the electronic module, which you have removed before.

**Exchange of a module group**

1. ➤ Remove if exists the wiring of the module group. ↪ *Chap. 3.7 'Wiring' page 88.*

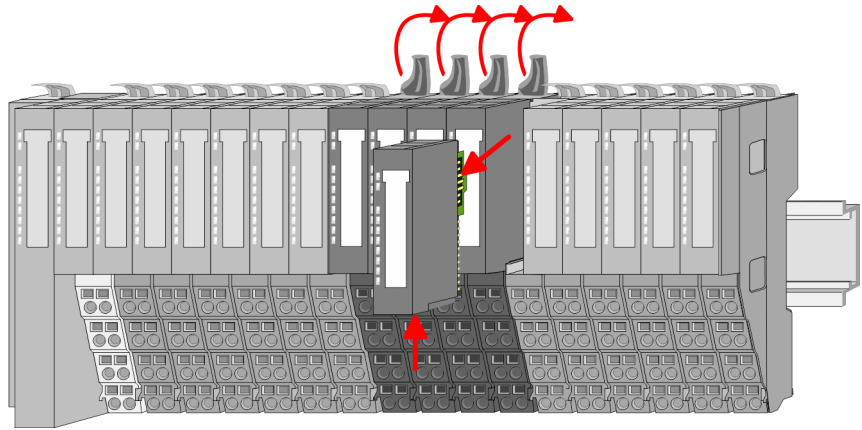

2. ➤ Press the unlocking lever at the lower side of the just mounted right module of the module group and pull it forward.

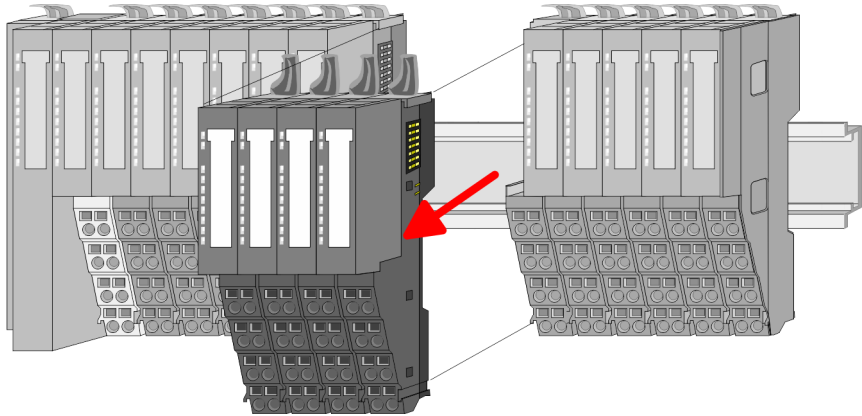

3. ➤ Turn all the locking lever of the module group to be exchanged upwards.

4. ➤ Pull the module group forward.

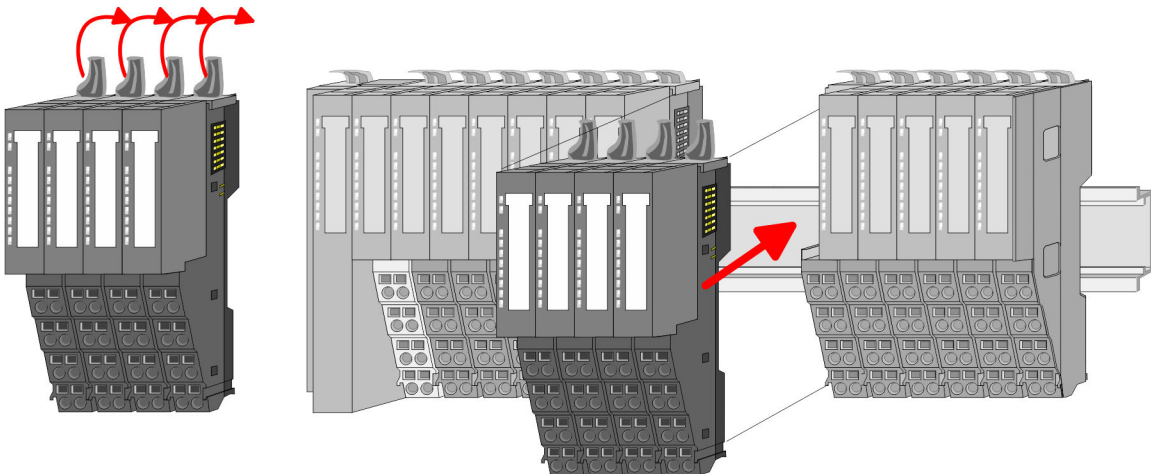

5. ➤ For mounting turn all the locking lever of the module group to be mounted upwards.

6. ➤ To mount the module group put it to the gap between the both modules and push it, guided by the stripes at both sides, to the mounting rail.

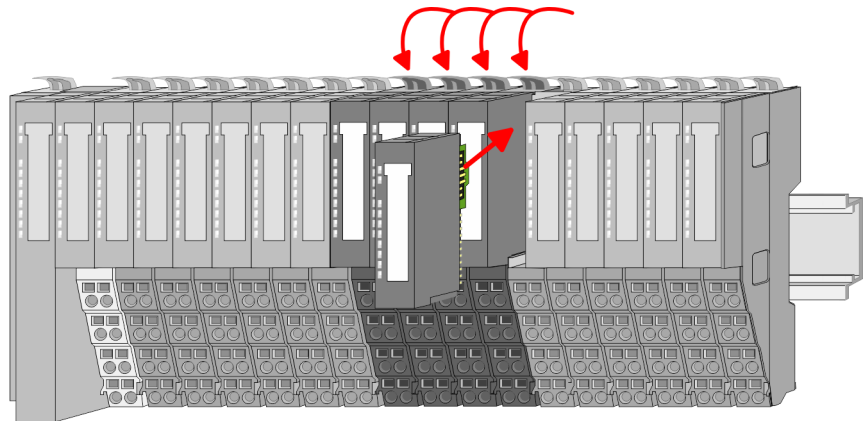

7. Turn all the locking lever downward again.
8. Plug again the electronic module, which you have removed before.

### 3.7 Wiring

#### Requirements on the electrical connection

To be able to fulfil the standard EN 60 204-1 (electrical equipment of machines), you have to use the cables, which are suggested there. The connectors may not drop away, otherwise the risk of short-cuts, external voltages etc. exists.

Pay attention to a EMC-compatible installation of the cables.



#### CAUTION!

##### Danger by electrical current!

The module can be destroyed/damaged, if you do not ensure the requirements for the electrical connection of the module.

- Make sure that the connected loads specified in the technical data are kept and that the connections are made in accordance with the specifications.
- Prevent a short-circuit between inputs and outputs. In the case of a short-circuit between inputs and outputs the electronic module can be destroyed.



#### CAUTION!

Please regard in particular that electromechanical sensors (safety switch-gears) are supplied with suitable clock pulses for short circuit detection.

Electromechanical switches must correspond to the requirements in accordance with IEC 60947-5-1.

#### Requirement to the power supply

For the adherence to the NAMUR recommendation NE 21 IEC 61131-2 and EN 298 you have to use power supply units (AC 230V / DC 24V) with a mains buffering of at least 20ms.



#### WARNING!

##### Risk of injury by electric current!

There may only devices be connected to the controller, which have a safe separation of the 230V power.

The power supply to generate 24V power must correspond to the requirements for PELV according to EN 60204-1.



**Terminals**

Terminals with spring clamp technology are used for wiring. The spring clamp technology allows quick and easy connection of your signal and supply lines.

In contrast to screw terminal connections this type of connection is vibration proof.

**Requirements for the connecting cable**

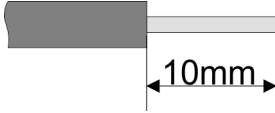

$U_{max}$ : 240V AC / 30V DC

$I_{max}$ : 10A

Cross section: 0.08 ... 1.5mm<sup>2</sup> (AWG 28 ... 16)

Stripping length: 10mm

**Wiring procedure**

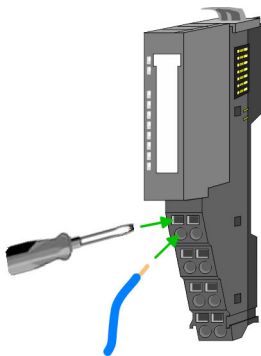
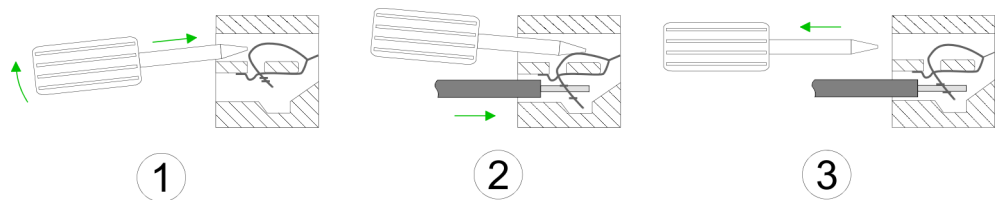

1. Insert a suited screwdriver at an angle into the square opening as shown. Press and hold the screwdriver in the opposite direction to open the contact spring.
2. Insert the stripped end of wire into the round opening. You can use wires with a cross section of 0.08mm<sup>2</sup> up to 1.5mm<sup>2</sup>.
3. By removing the screwdriver, the wire is securely fixed via the spring contact to the terminal.

**Wiring power supply**

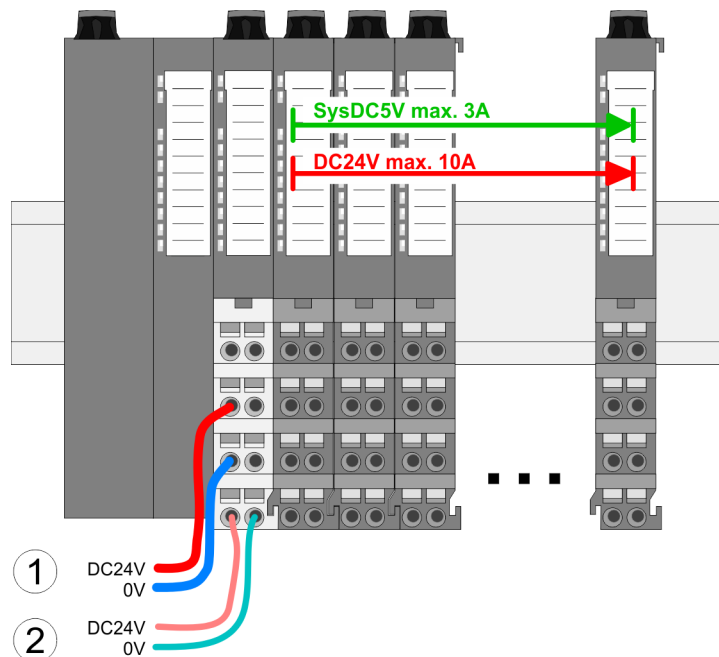

- (1) DC 24V for power section supply I/O area (max. 10A)
- (2) DC 24V for electronic power supply bus coupler and I/O area

**NOTICE!**

Since the power section supply is not internally protected, it is to be externally protected with a fuse, which corresponds to the maximum current. This means max. 10A is to be protected by a 10A fuse (fast) respectively by a line circuit breaker 10A characteristics Z!



*The electronic power section supply is internally protected against higher voltage by fuse.*

*The fuse is within the power module. If the fuse releases, its electronic module must be exchanged!*

**Fusing**

- The power section supply is to be externally protected with a fuse, which corresponds to the maximum current. This means max. 10A is to be protected with a 10A fuse (fast) respectively by a line circuit breaker 10A characteristics Z!
- It is recommended to externally protect the electronic power supply for bus coupler and I/O area with a 2A fuse (fast) respectively by a line circuit breaker 2A characteristics Z.
- The electronic power supply for the I/O area of the power module 007-1AB10 should also be externally protected with a 1A fuse (fast) respectively by a line circuit breaker 1A characteristics Z.

**State of the electronic power supply via LEDs**

After PowerON of the System SLIO the LEDs RUN respectively MF get on so far as the sum current does not exceed 3A. With a sum current greater than 3A the LEDs may not be activated. Here the power module with the order number 007-1AB10 is to be placed between the peripheral modules. [↪ 'Power module 007-1AB10' page 91](#)

**Deployment of the power modules**

- If the 10A for the power section supply is no longer sufficient, you may use the power module with the order number 007-1AB00. So you have also the possibility to define isolated groups.
- The power module with the order number 007-1AB10 is to be used if the 3A for the electronic power supply at the backplane bus is no longer sufficient. Additionally you get an isolated group for the DC 24V power section supply with max. 4A.
- By placing the power module 007-1AB10 at the following backplane bus modules may be placed with a sum current of max. 2A. Afterwards a power module is to be placed again. To secure the power supply, the power modules may be mixed used.

**Power module 007-1AB00**

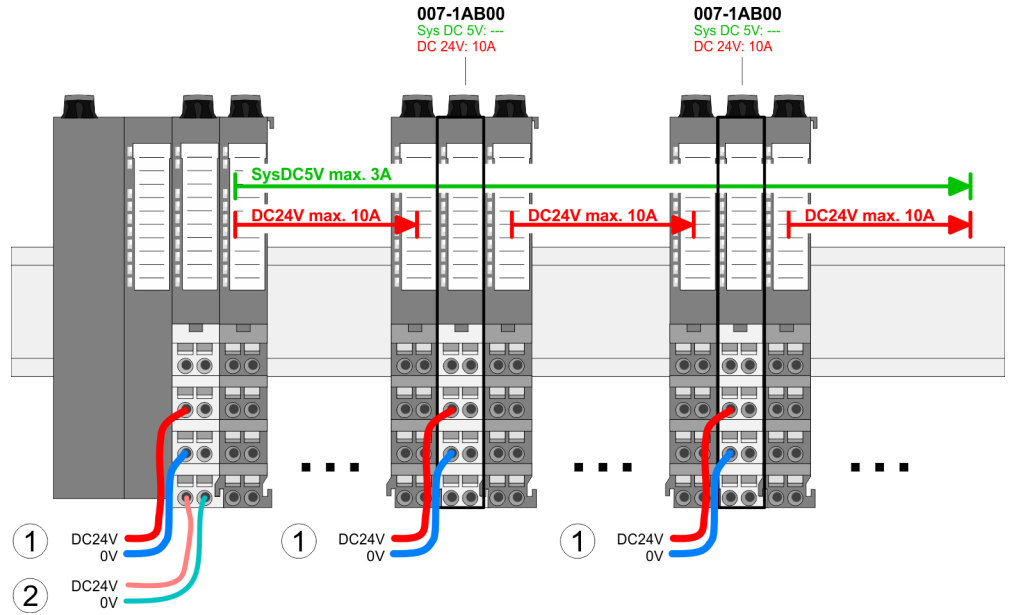

**Power module 007-1AB10**

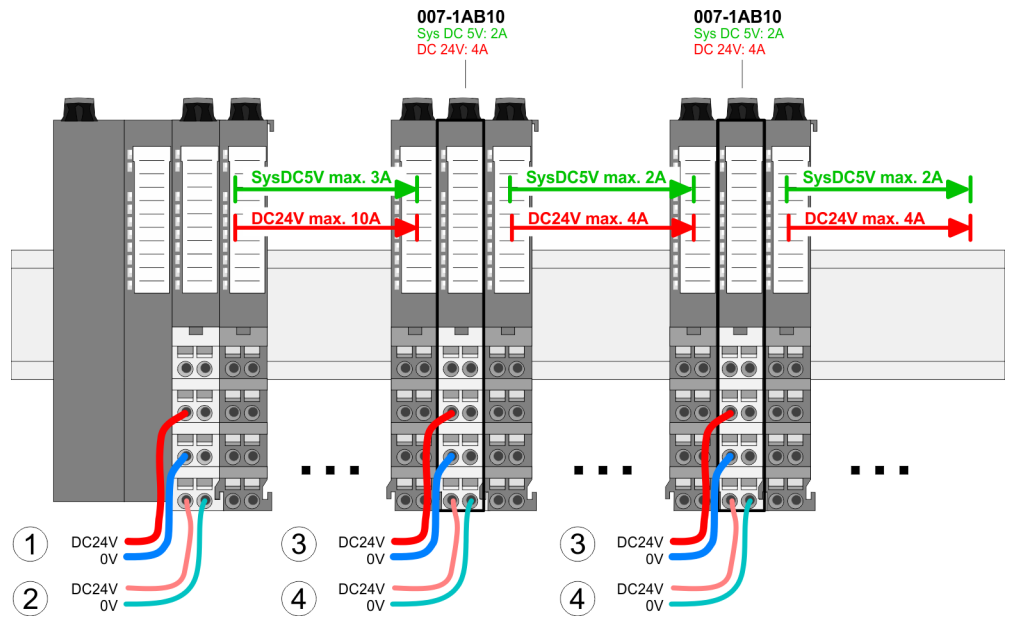

- (1) DC 24V for power section supply I/O area (max. 10A)
- (2) DC 24V for electronic power supply bus coupler and I/O area
- (3) DC 24V for power section supply I/O area (max. 4A)
- (4) DC 24V for electronic power supply I/O area

**Shield attachment**

- To attach the shield the mounting of shield bus carriers are necessary.
- The shield bus carrier (available as accessory) serves to carry the shield bus to connect cable shields.
- The shield bus carrier is mounted underneath the terminal of the terminal module. With a flat mounting rail for adaptation to a flat mounting rail you may remove the spacer of the shield bus carrier.
- After mounting the shield bus carrier with the shield bus, the cables with the accordingly stripped cable screen may be attached and fixed by the shield clamp.

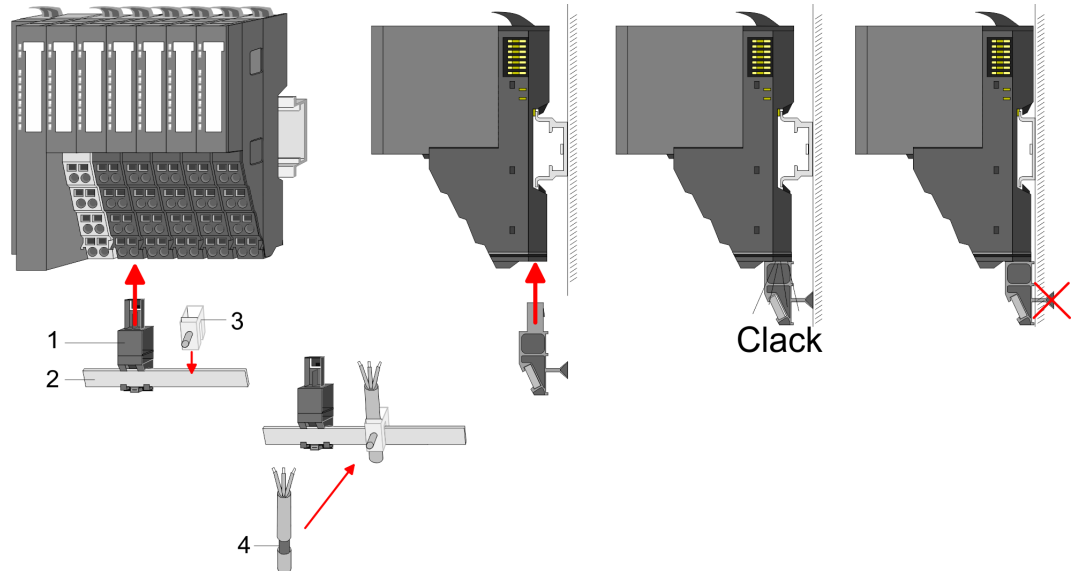

- 1 Shield bus carrier
- 2 Shield bus (10mm x 3mm)
- 3 Shield clamp
- 4 Cable shield

### 3.7.1 Requirements to the sensor and actuators

Note the following warning in terms of safety-oriented operation of sensors and actuators:



#### CAUTION!

A safety system always consists of sensors, logic and actuators. The usage of the sensors and actuators lies outside of our sphere of influence. We equipped our electronics safety-relevant in such a way that we can offer you for the sensors and actuators 85% of the maximally permissible probability of dangerous errors (corresponds to the recommended dispatch between sensors, actuators and the electronic circuits for input, processing and output in expenditure in safety technology).

Instrumentation using sensors and actuators poses considerable safety responsibility. For all sensors and actuators, the probabilistic proof must be calculated using "SISTEMA" or an appropriate tool. "SISTEMA" is a software tool for evaluating safety-related machine controls according to DIN EN ISO 13849. This ensures that the safety circuit consisting of sensor + logic + actuator fulfils the normative requirement in total. This must generally be ensured for all safety circles!

A safety function must comply in terms of the probability and rate of hazardous faults with limits determined by the safety integrity level (SIL). For the System SLIO safety modules, you can find the values achieved at "Safety-relevant parameters". ↪ *Chap. 1.17 'Functional safety - safety relevant parameters' page 17*

When planning proof tests for the entire safety system, note that sensors and actuators generally require significantly shorter proof test intervals than the System SLIO safety modules with a device life of 20 years without a proof test.

#### Requirements to the sensors

The System SLIO safety DI module can be used with cable length up to 330m (capacity up to 100nF, ohmic resistance up to 22.4Ω). General rule: A single-channel sensor is sufficient to achieve SIL2/Cat. 3/PLd; to achieve SIL3/Cat.4/PLe, sensors must be connected via two channels.

**Duration of the sensor signals**

Note the following requirements on the sensor signals:

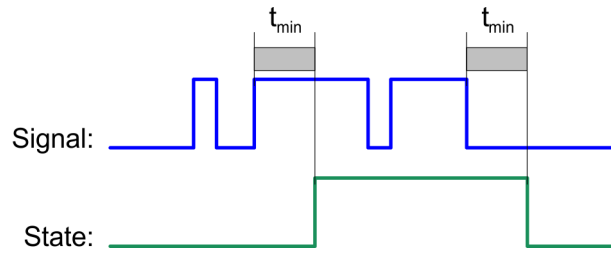

**CAUTION!**

In order to guarantee accurate detection of sensor signals by the safety DI module, you must ensure that the sensor signals have a defined *minimum duration*.

The *minimum duration* is a minimum switch-on and switch-off duration, which is necessary to detect a signal in the worst case. The time interval between two signal transitions must be greater than the Sync Manager monitoring time (SM Watchdog) for EtherCAT communication to allow reliable detection of the pulses. This must be specified in the *SPEED7 EtherCAT Manager* within the parameters for the slave station.

**Reliable detection by the safety DI module**

Parameter short-circuit test	Parametrized input delay		
	1ms	3ms	15ms
de-activated	7ms	9ms	23ms
activated	8ms	12ms	37ms

In the table exemplary the minimum duration of the sensor signals of the safety DI module is shown. It depends on the configuration of the short-circuit test and the input delay in the Configuration tool of the FSoE master.

**Requirements to the actuators**

The safety-related output modules perform a cyclic test of the outputs. The F module briefly disables the activate outputs. This test pulse lengths can be parametrized to match the load current and the cable capacitance / length.

In the table below you will find orientation values for the *test pulse length*:

Load current	Cable length (capacity, resistor)	Test pulse length to be configured
2 mA	100 m (30 nF, up to 6.7 Ohm)	2500 µs
2 mA	333 m (100 nF, up to 22.4 Ohm)	3500 µs
2 mA	1000 m (300 nF, up to 67 Ohm)	6000 µs
5 mA	100 m (30 nF, up to 6.7 Ohm)	2000 µs
5 mA	333 m (100 nF, up to 22.4 Ohm)	2500 µs
5 mA	1000 m (300 nF, up to 67 Ohm)	4000 µs
> 25 mA	100 m (30 nF, up to 6.7 Ohm)	1000 µs
> 25 mA	333 m (100 nF, up to 22.4 Ohm)	1000 µs
> 25 mA	1000 m (300 nF, up to 67 Ohm)	1500 µs

High-speed actuators may briefly drop out or be activated during this test. If your process does not tolerate this action you must use actuators with a sufficient lag (> 1 ms).

**CAUTION!**

The outputs of a fail-safe output module must be electrically isolated to EN 50178 from components which carry higher voltages if the actuators are operated at voltages higher than 24 V DC, for example, at 230 V DC, or are being used to switch higher voltages. ↪ *Chap. 3.1 'Planning of a safety-related control system' page 68*

Relays and contactors usually comply with this rule, is to be proved separately. This aspect is of particular importance when using semiconductor switchgear.

These components must be considered in the security calculation like the System SLIO safety modules.

### 3.8 Connection examples



#### **WARNING!**

#### **Warning against personal and property damage!**

The use of the connection examples described in this section alone is not enough to execute the safety function according to the SIL, Cat./PL determined from the risk analysis. In connection with safe devices, sensors and actuators, additional measures may be necessary to ensure the safety function. This includes, for example, the appropriate wiring and parameterization of digital inputs and outputs, as well as measures to exclude unforeseeable errors.

More information is available in the user manuals of the safe devices used.

#### **General**

The section generally describes possible applications, in which the functions of the System SLIO safety module for implementation of a safety function are used. You can only use the depicted connection examples in a tangible safety application after a performed risk analysis.



#### **CAUTION!**

#### **Please consider at single-channel operation!**

At single-channel operation the demand rate of the safety functions from SIL2 or PLd is max. 1/100 of the test rate!

- System SLIO safety input
  - The test rate for the System SLIO safety input module at single-channel operation is 1x per 150ms. This means the max. demand rate is 1x per 15s.
  - You have to evaluate the external components, which are used in single-channel operation, regarding the demand rate (e.g.: manual check of a single-channel protection door switch).
- System SLIO safety output
  - In single-channel operation each output-channel of the System SLIO safety output module internally exists twice (serial redundant). Therefore, the requirement with regard to the demand rate is not applicable.
  - But you have to evaluate the external components, regarding the demand rate, which are used in single-channel operation.



#### **CAUTION!**

#### **Please note for 1-channel operation of the safety output module!**

With 1-channel operation according to Cat.2 / PL d of the safety output module, the user program must always react in the event of a diagnostic so that a safe state is initiated. This must be ensured by the application and can not be realized by the safety module itself.



### 3.8.1 Connection examples for digital inputs

You can operate e.g. the following sensors on the digital inputs:

- Potential-free, contact emergency off buttons
- Protective door switches
- Light array (general contactless protection system) with the following characteristics:
  - the outputs are source-mode outputs
  - the outputs must be compatible to IEC 61131-2



#### WARNING!

#### Achievable SIL, Cat./PL for single-channel use of the digital inputs!

The achievable SIL, Cat./PL depends on the quality of the safe sensors. This must be certified according to EN 60947-5-1 /-5.

#### 3.8.1.1 Emergency Off connection, single-channel

**Connection 4 x emergency off, single-channel, *Test pulse activation active***

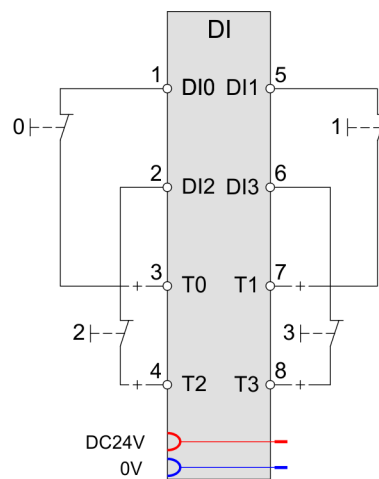

**Connection 4 x emergency off, single-channel, *Test pulse activation* not active**

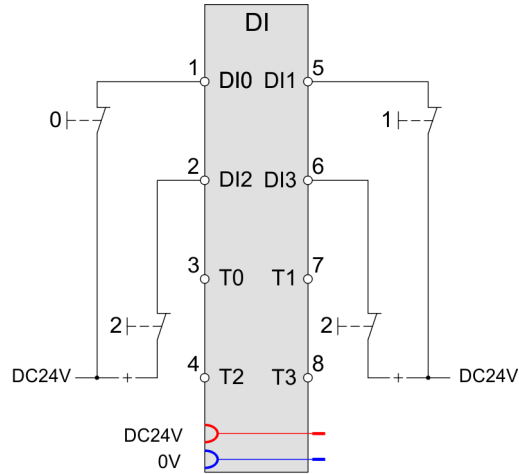

- You can connect the digital input via a switching element (e.g., an emergency off switch) either to the associated clock output or to the field supply voltage  $U_v$  directly. Alternatively, you can connect the semiconductor output of a sensor to the digital input directly. For the single-channel use if a digital input, you must set the parameter *Evaluation of the inputs* to "1-channel".
- If you do not connect the digital input via a switching element to the associated clock output (e.g., semiconductor output), set the *Test pulse activation* to "deactivated". Otherwise, the safety module detects a short circuit on the input and reports the "Short circuit" diagnostic message.
- If you connect the digital input via the switching element to the associated clock output and the safety module should monitor the signal line for short circuits, you have to set the parameter *Test pulse activation* to "activated".



*Please consider the instructions for single-channel operation with regard to the demand rate. ↪ Chap. 3.8 'Connection examples' page 96*

### Connection 2 x emergency-off switch, dual channel, equivalent evaluation

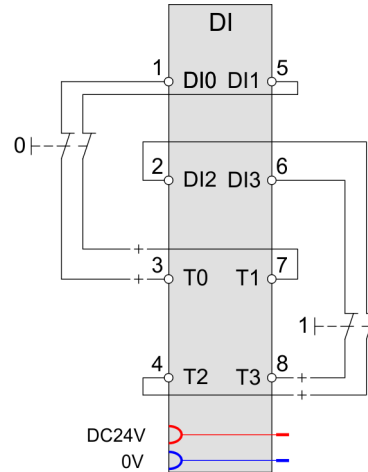

#### WARNING!

**Pay attention to the protected installation of signal lines during *Test pulse activation* is "deactivated"!**

If you have set the parameter *Test pulse activation* to "deactivated", as condition of fault exclusion, the signal lines must be installed protected among each other and between the sensors and inputs according to EN 60204-1 or EN ISO 13849-2 (e.g., as separate sheathed lines or in separate cable ducts).

- For emergency off applications that require single fault security, you can connect two digital inputs via two switching elements (two-channel emergency off switches with two break contacts) to the safety module.
- Use the Configuration Tool for the FSoE Master to set the parameters. ↪ *Chap. 3.10 'Deployment with EtherCAT' page 108*
- Set the parameter *Evaluation of the inputs* to "2-channel" and *Signal polarity* to "equivalent". In addition, set the *Discrepancy timeout* parameter to the discrepancy time required for the two switching elements. In addition, set the *Discrepancy timeout* parameter to the discrepancy time required for the two switching elements.
- You can set the *Test pulse activation* of both inputs used to "activated" or "not active". Please note that the *Test pulse activation* parameter must be set the same for both digital inputs. If you connect the digital inputs via the switching elements directly to the field voltage of DC +24 V or to two semiconductor outputs of a sensor, then you have to set the *Test pulse activation* parameter to "deactivated" because otherwise the safety module wrongly detects a short circuit and reports the "Short circuit" diagnostic message.
- The safe sensors used must be certified according to EN 60947-5-1 /-5.
- When using electronic sensors with semiconductor outputs you can achieve SIL3/ Cat.4/PLe.

### 3.8.1.2 Connection interlock monitoring

#### Connection 1 x interlock monitoring, dual channel, antivalent evaluation

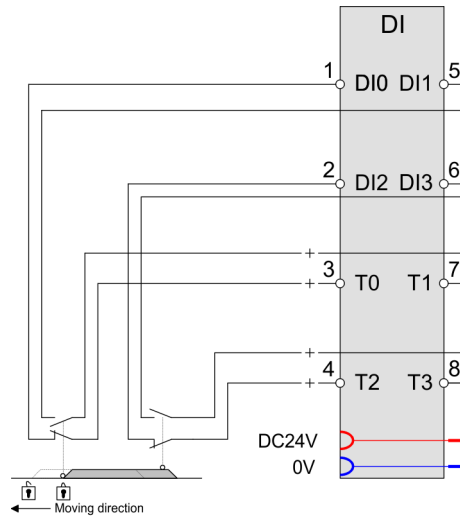

- To monitor protective devices, you can connect the normally open contact of a protective door switch to four digital inputs of the safety module.
- Use the Configuration Tool for the FSoE Master to set the parameters. ↗ *Chap. 3.10 'Deployment with EtherCAT' page 108*
- Set the parameter *Evaluation of the inputs* to "2-channel".
- So that the signal lines of the digital inputs of the safety module are monitored for short circuits, for every input set the *Test pulse activation* to "activated".
- You must set the parameter *Signal polarity* to "antivalent". In addition, set the *Discrepancy timeout* parameter to the discrepancy time required for the normally open contact of the protective door switch.
- You can achieve SIL3/Cat.4/PLe with this circuit.

### 3.8.1.3 Connection light array

#### Connecting a light array

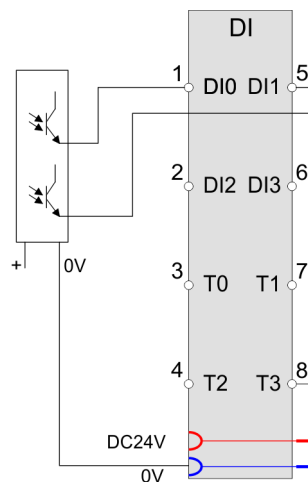

- For light array applications which require single fault security, you can connect two digital safety inputs to the according light array outputs.
- Here set the parameter *Evaluation of the inputs* of the digital safety inputs to "2-channel".
- For this the *Input smoothing time* of the according safety input must always be greater than the *Test pulse length* of the light array output (manufacturer data).
- Set the parameter *Test pulse activation* to "deactivated". Otherwise, the safety module wrongly detects a short circuit on the input and reports the "Short circuit" diagnostic message.

### 3.8.2 Connection examples for digital safety outputs

The following loads can be operated on the digital safety outputs:

- resistive loads
- inductive load after DC13 according EN 60947-5-1



#### **Wire break detection at the digital safety output**

*To detect a wire break between the safety outputs DO 0 ... 3 and 0V to the connected load, for each safety output the parameter wire break detection may separately be set. The error wire break is reported if the output current is less than 10 ... 30mA. This error stops the module.*

#### 3.8.2.1 Switching inductive loads

You can operate inductive loads on the digital safety outputs of the SLIO safety module by using the internal recovery circuit. Consider the maximum switching frequency of 0.1Hz.



#### **WARNING!**

**Defect by thermal overheating if the switching frequency is too high!**

If the inductivity and load current you have selected is too high for the selected switching frequency, it can lead to thermal destruction of the digital safety output.

Destruction of the digital safety output can cause the safety function to fail.

#### **Selecting an external diode recovery circuit**

If you use a suitable external diode recovery circuit, then the magnetic energy when shutting down the inductive load is not converted in the SLIO safety module, but on the external diode recovery circuit.



#### **NOTICE!**

The external diode recovery circuit must be designed for the resulting heat loss.

**Connection with diode recovery circuit**

When shutting down an inductive load, the magnetic energy stored in the inductive load must be dissipated. This magnetic energy converted by a diode recovery circuit into heat. You can convert the magnetic energy into heat with the SLIO safety module or with a suitable external diode recovery circuit.

These components must be considered in the security calculation like the System SLIO safety modules.

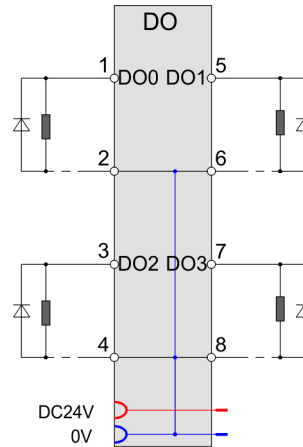

Please consider the instructions for single-channel operation with regard to the demand rate. ↪ Chap. 3.8 'Connection examples' page 96

**3.8.2.2 Switching electronic loads**

You can switch electronic loads (e.g., electronically controlled door locking device) using the System SLIO safety module.



**Switching electronic loads**

When switching electronic loads, increased inrush currents that significantly exceed the rated current can be caused by internal capacities in the electronic loads. This can lead to passivation of the System SLIO safety module with the "Overload" diagnostic message. You can remedy this by limiting the inrush current, e.g., by placing an additional series resistor between the digital safety output and the electronic load.

**Schematic diagram**

The following schematic diagram shows the internal two channel system of the System SLIO safety module.

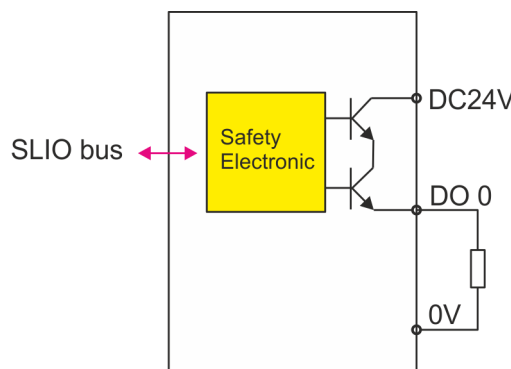

**Connection a load to a safety output**

In the following the connection of a load (relay respectively pneumatic valve) to an output with optional feedback (switch respectively pneumatic pressure switch) to a System SLIO safety input module is shown.

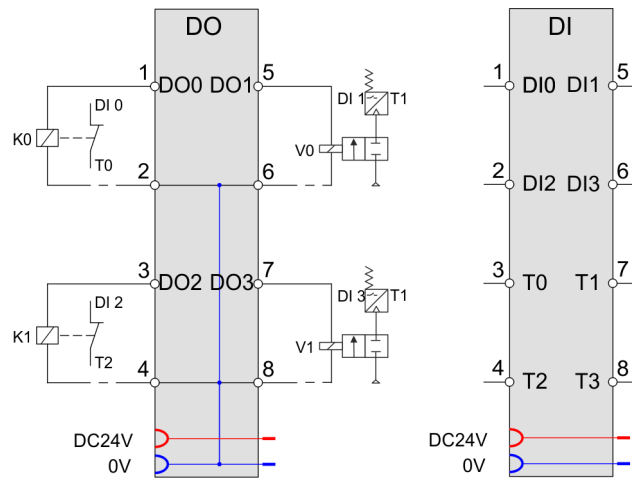

**Connection 2 parallel connected loads to a safety output**

With this connection, you can achieve SIL3/Cat.4/PLe by re-reading the relay states on the condition that in the external wiring a cross-circuit to the power supply can be excluded.

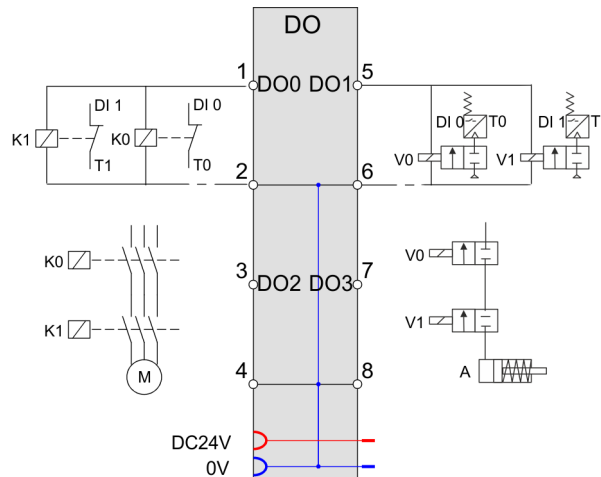

**WARNING!**

**Pay attention to the protected installation of signal lines!**

The plant or control cabinet builder can autonomously carry out a fault exclusion based on DIN EN ISO 13849-2:2013-02/EN ISO 13849-2:2012 (D) to achieve the PLd with certain requirements. The procedure is described in table D.4 - 'Errors and error exclusions - lines/cables' (with reference to EN 60204-1. The measures described there are, for example, separately jacketed cables, separate cable ducts, installation within an electrical installation space). For PLe, it is generally not permissible to exclude errors at the subsystem level!



Set the parameter *Activation mode of the according safety output* to 1-channel.

**Connection load to safety output and ground 0V**

With this connection, you can achieve SIL3/Cat.4/PLE by re-reading the relay states.

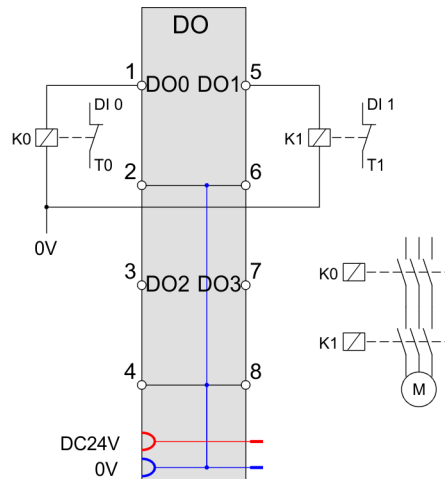

You can connect a load (e.g., a relay) between a digital safety output DO 0 ... 3 and the ground connection 0V of the field power supply. It is not necessary to lead back the ground connection to the according connection of the System SLIO safety module.

Please observe the following conditions:

- Ensure for the fact that the relay and the System SLIO safety module have the same reference potential.
- For single fault security, you need at least 2 relays and the cross- circuit fault on the supply voltage must be excluded by a protected wiring
- You must connect the normally open contacts (K0 and K1) of 2 relays in series to the load to be switched.

**Connection digital safety outputs to digital safety inputs**

In the following it is shown how to connect the safety outputs DO 0 ... 3 to the safety inputs of a System SLIO safety input module.

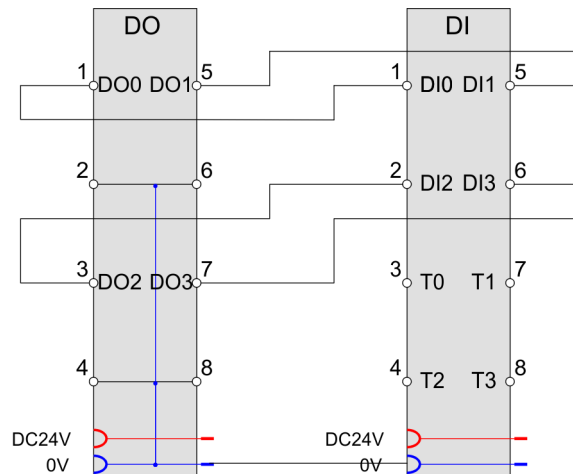

- For the according safety input you have to set the parameter *Test pulse activation* to "deactivated". Otherwise, the safety module detects a short circuit on the input and reports the "Short circuit" diagnostic message.
- For this the *Input smoothing time* of the according safety input must always be greater than the *Test pulse length* of the safety output.



*In this case wire break detection is not possible!*



**Connection 4 motors, external single-channel with feedback (1 contactor per motor)**

You can connect a contactor to a digital safety output and connect a motor single-channel using normally open contacts of the contactor. Connection is possible to each of the four digital safety outputs. You must observe the warning messages for single-channel use. With this connection, you can achieve SIL2/Cat.2/PLd by re-reading the relay states.



Please consider the instructions for single-channel operation with regard to the demand rate. ↪ Chap. 3.8 'Connection examples' page 96

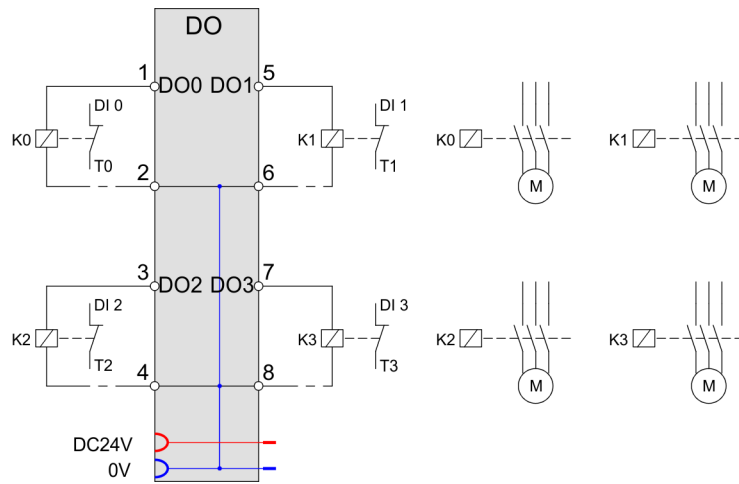

**WARNING!**  
**Important note to single fault security!**

Never use a single digital safety output alone for the safety function if single fault security is required!

If single fault security is required, you have to integrate a second disconnection facility (e.g., a line contactor K4) in the safety application by e.g. analysing the relay states read back.

**Connection 4 motors, 2-channel with feedback (2 contactor per motor)**

With this connection, you can achieve SIL3/Cat.4/PLe by re-reading the relay states.

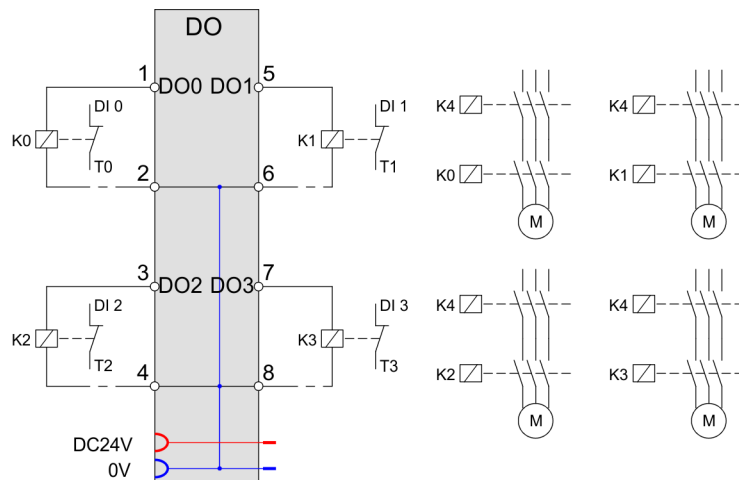

**Connection 2 motors, 2-channel with feedback (2 contactor per motor)**

With this connection, you can achieve SIL3/Cat.4/PLe by re-reading the relay states.

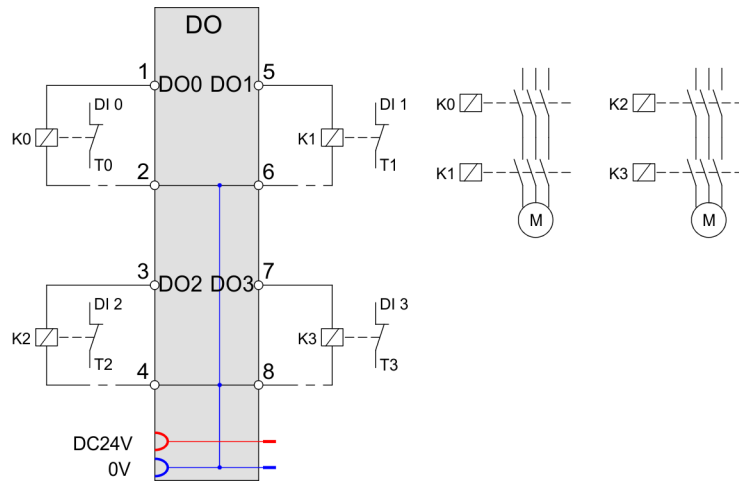

- To achieve signal fault security, we recommend the use of two positively driven normally open contacts of a contactor in series to the motor to be connected. These can originate from one contactor or from two different contactors.
- Connect the contactors between the digital safety outputs.

### 3.9 Notes for commissioning

#### General

The Commissioning guarantees that the System SLIO safety module functions correctly. Guarantee before commissioning that the following conditions are fulfilled:

- The digital module is correctly installed.
- The digital module is connected to safety components (Emergency stop device, safety light array etc.).
- The safety devices are activated.



*For the operation the ambient data, which are specified in the technical data must be adhered to! Commissioning is only permitted after the acclimation of the System SLIO safety modules! ↪ Chap. 2.6 'SDI 4xDC 24V - Technical data' page 42, ↪ Chap. 2.10 'SDO 4xDC 24V 0.5A - Technical data' page 57*



#### **WARNING!**

##### **Risk of injury by electric current!**

In the phase commissioning the check list "Check list commissioning and validation" in the appendix must be used. ↪ *Appendix C 'Checklist commissioning, parameterization and validation' page 137*

- Make sure that the system is exclusively commissioned by qualified personnel.
- Make sure during the commissioning that there is no person in the danger zone. You always may reckon that the machine, plant or safety device do not behave in such a way, as it is intended.
- If there are changes or extensions on the system during commissioning, influences to the system behaviour must be checked. Here the check lists for planning and installation must be handled again.



#### **DANGER!**

##### **Risk of injury from moving parts!**

During the commissioning machine parts / components or the entire machine / plant can move.

- Keep a sufficient distance from any moving parts of machinery / equipment or parts from the moving machine / plant.
- Note that via attached further modules the parts of machinery / equipment or parts from the moving machine / plant can set to motion.
- Activate in each case their safety devices.

#### Requirements to the operating personnel

The work for commissioning must be performed by professionally trained personnel, who in particular understands and acts on the safety regulations and notes.



#### **DANGER!**

##### **Risk by mechanical influence!**

During the commissioning of the module the machine / plant or parts of the machine / plant may be moved by a completely available application program.

- Keep a sufficient distance from any moving parts of machinery / equipment or parts from the moving machine / plant.

## 3.10 Deployment with EtherCAT

### 3.10.1 Basics EtherCAT:

#### EtherCAT®

- For EtherCAT® is valid: EtherCAT® is a registered trademark and patented technology, licensed by Beckhoff Automation GmbH, Germany.
- EtherCAT means Ethernet for Controller and Automation Technology. It was originally developed by Beckhoff Automation GmbH and is now supported and further developed by the EtherCAT Technology Group (ETG). ETG is the world's biggest international user and producer connection for industrial Ethernet.
- EtherCAT is an open Ethernet based field bus system, which is standardized at the IEC.
- As an open field bus system EtherCAT matches the user profile for the part of industrial real-time systems.  
In opposition to the normal Ethernet communication at EtherCAT the data exchange of I/O data takes place during the frame passes the coupler with 100Mbit/s in full-duplex. Since in this way a frame to send and receive direction reaches the data of many stations, EtherCAT has a rate of user data of over 90%.
- The EtherCAT protocol, which is optimized for process data, is directly transported with the Ethernet frame. This again can consist of several sub-frames, which serve for a storage area of the process image.



Safety over EtherCAT® is a registered trademark and patented technology, licensed by Beckhoff Automation GmbH, Germany.

#### Transfer medium

- EtherCAT uses Ethernet as transfer medium.
- Standard CAT5 cables are used. Here distances of about 100m between 2 stations are possible.
- Only EtherCAT components may be used in an EtherCAT network.
- For topologies, which depart from the line structure, the corresponding EtherCAT components are necessary.
- Hubs may not be used.

#### Communication principle

- At EtherCAT the master sends a telegram to the first station. The station takes its data from the current data stream, inserts its answer data and sends the frame to the succeeding station. Here the frame is handled with the same way.
- When the frame has reached the last station this recognizes that no further is connected and sends the frame back to the master. Here the telegram is sent through every station via the other pair of leads (full-duplex). Due to the plug sequence and the use of the full-duplex technology EtherCAT represents a logical ring.

#### EtherCAT State Machine

Via the EtherCAT State Machine the state of the EtherCAT devices is controlled.

#### Object dictionary (SDOs)

- In the object directory the parameter, diagnostics, Interrupt or other data are listed, which may be written or read via EtherCAT.
- The object directory may be accessed by the SDO information service.
- Additionally the object directory may be found in the device master file.

- Process data (PDOs)**
- The EtherCAT data link layer is optimized for the fast transfer of process data. Here it is specified how the process data of the device are assigned to the EtherCAT process data and how the application of the device is synchronized to the EtherCAT cycle.
  - The mapping of the process data happens by PDO mapping and by Sync-Manager-PDO-Assign objects. These describe, which objects of the object directory are transferred as object data via EtherCAT.
  - The cycle time to transfer the process data via EtherCAT and how this is synchronized for the transfer is specified with the Sync-Manager-Communication objects.
- Emergencies**
- Via Emergencies diagnostics, process events and errors at state change of the State Machine may be transferred.
  - Status messages, which show the current state of the device, should directly be transferred within the process data.
- ESI files**
- You got ESI files from Yaskawa for the EtherCAT coupler. This file may be found at the Download Center of [www.yaskawa.eu.com](http://www.yaskawa.eu.com).
  - Install the ESI files in your configuration tool.
  - More information about installing the ESI file may be found in the manual of the according engineering tool.
  - For configuration in your configuration tool, every System SLIO module may be found in the ESI files as XML data.

### 3.10.2 General information on deployment

- General**
- The programming of the safety program and the parametrization of the safety modules are carried out in the configuration tool of the FSoE master. Here an  $ESI_{FSoE\ master}$  is to be exported.
  - In the *SPEED7 EtherCAT Manager*, the EtherCAT master is to be integrated as slave system by means of the  $ESI_{FSoE\ master}$ .
  - The configuration of the EtherCAT system with the System SLIO I/O modules takes place in the *SPEED7 EtherCAT Manager* by means of the  $ESI_{FSoE\ slave}$ .
- ESI files**
- $ESI_{FSoE\ master}$  - ESI file which is to be generated in the configuration tool of the master. To use the safety parameters, these must be imported into the *SPEED7 EtherCAT Manager*.
- $ESI_{FSoE\ slave}$  - ESI file of the System SLIO for configuring the System SLIO modules in the *SPEED7 EtherCAT Manager*. The ESI file is to be installed if modules are not available in the hardware catalog.
- Configuration**
1. ➤ Start the FSoE master configuration tool.
  2. ➤ Import the  $ESI_{FSoE\ slave}$ .
  3. ➤ Configure and program your System SLIO safety modules.
  4. ➤ Transfer your safety project to the FSoE master.
  5. ➤ Export the  $ESI_{FSoE\ master}$ .
  6. ➤ Close the configuration tool.
  7. ➤ Start the Siemens SIMATIC Manager or the TIA Portal.
  8. ➤ Configure a CPU 015-CEFNR00 as the master CPU for the EtherCAT slave.

9. ➤ Connect the IO 'SLIO EtherCAT System' to your PROFINET system and define the areas for input and output. More details can be found in the corresponding manual for your CPU.
10. ➤ Start the *SPEED7 EtherCAT Manager*.
11. ➤ Import the  $ESI_{FSoE\ master}$ .
12. ➤ Place the FSoE master as the 1. EtherCAT slave system.
13. ➤ For the EtherCAT network with all I/O modules as 2. EtherCAT slave system, place the System SLIO FSoE slave.
14. ➤ Parametrize the I/O modules and adapt the address mapping if necessary.
15. ➤ Close the *SPEED7 EtherCAT Manager* and transfer your project to the master CPU.

### 3.10.3 Parametrization System SLIO safety module

The System SLIO safety modules must only be placed in the *SPEED7 EtherCAT Manager*. The parametrization of the System SLIO safety modules takes place in the configuration tool of the FSoE master and is to be exported as  $ESI_{FSoE\ master}$ . By importing the  $ESI_{FSoE\ master}$  into the *SPEED7 EtherCAT Manager*, the FSoE master can be integrated into EtherCAT as a slave system.

### 3.10.4 Generate safety program



*As soon as you change a parameter of a System SLIO safety module in the hardware configuration, you must validate it with the configuration tool of the FSoE master, transfer the new configuration and import the new  $ESI_{FSoE\ master}$  into the *SPEED7 EtherCAT Manager*. Then you have to refresh the hardware configuration in your master CPU.*

### 3.10.5 Diagnostic messages EtherCAT

Code	Description
0x01	FSoE telegram error: unexpected command
0x02	FSoE telegram error: unknown command
0x03	FSoE telegram error: invalid connection ID
0x04	FSoE telegram error: CRC error
0x05	FSoE communication error: Watchdog expired
0x06	FSoE telegram error: Invalid FSoE slave address
0x07	FSoE telegram error: Invalid safe data
0x81 - 0x96	Internal error <ul style="list-style-type: none"> <li>■ ERR LED: 5x blinking</li> </ul>

Code	Description
0x97	<p><i>Short circuit</i></p> <p>Short circuit within one channel to DC 24V</p> <ul style="list-style-type: none"> <li>■ ERR LED: 1x blinking</li> <li>■ Diagnostic data CHxERR Bit 0 is set</li> </ul>
0x98	<p><i>Channel cross-circuit detected</i></p> <p>Cross-circuit error between 2 channels</p> <ul style="list-style-type: none"> <li>■ ERR LED: 2x blinking</li> <li>■ Diagnostic data CHxERR Bit 3 is set</li> </ul>
0x99	<p>Only SDO 4xDC 24V 0.5A:</p> <p>Wire-break on one channel (current &lt;30mA)</p> <ul style="list-style-type: none"> <li>■ ERR LED: 3x blinking</li> <li>■ Diagnostic data CHxERR Bit 2 is set</li> </ul>
0x9A	<p>Only SDO 4xDC 24V 0.5A:</p> <p><i>Ground fault</i></p> <p>Read back error, i.e. on one channel the set-point and current state do not match, e.g. short circuit to ground.</p> <ul style="list-style-type: none"> <li>■ ERR LED: 4x blinking</li> <li>■ Diagnostic data CHxERR Bit 1 is set</li> </ul>
0x9B	<p>Only SDI 4xDC 24V:</p> <p><i>Channel discrepancy detected</i></p> <p>Discrepancy error between 2 channels</p> <ul style="list-style-type: none"> <li>■ ERR LED: 3x blinking</li> <li>■ Diagnostic data CHxERR Bit 4 is set</li> </ul>
0x9C - 0xA8	<p>Internal error</p> <ul style="list-style-type: none"> <li>■ ERR LED: 5x blinking</li> </ul>
0xA9	<p><i>Safety Module F-Address EEPROM unequal DIP switch</i></p> <p>F-address was changed: The F-address set with the DIP switches does not match the stored F-address, i.e. the safety module has already been parametrized appropriately and then the F-address has been changed.</p> <ul style="list-style-type: none"> <li>■ ERR LED: 6x blinking</li> <li>■ Diagnostic data ERR_D: Bit 6 is set</li> </ul>
0xFF	<p>Error in the parameter data.</p>

### 3.11 Validation of the system

#### General

With the first commissioning all the safety functions and the proper functionality of the programmed and installed system must be checked. And the check of the system must be documented.



#### **WARNING!**

#### **Danger with commissioning!**

The control system may be operated only after successful testing by a competent person.

- Perform a complete functional test and check the correct assignment of the connected safety components.
- In the Appendix there is a checklist "Commissioning and validation" for commissioning and validation of the system. Perform the system validation in accordance to this checklist and document this accordingly. ↪ *Appendix C 'Checklist commissioning, parameterization and validation' page 137*
- Make sure that the service personnel is trained in the handling of the control system.

#### Function test

The function test is the main part of the validation of the entire system. The perfect allocation of the safety components of the network and the programmed logic of the system can be determined by the function test. Depending on the complexity of the combinational logic of the according project it is recommended to execute graded function tests. The following proceeding for function tests is recommended:

- Connect the actuators and drives with the safe output terminals only if while checking the wiring no errors were found.
- Examine a fully IO test. This means in order to bring all the sensors in each switch positions, each (normally on, off respectively actuated, not actuated).
  - Please check whether the specified and expected signal state is also the real state.
  - Please also check whether the state of the corresponding variables also accordingly changes in the safety PLC (a detailed description of this test can be found in the manual of your safety PLC).
  - You have to check the actuators as well when you want to control them with your safety output modules. You have to check each process state, which is specified in the safety application, as well.
  - If the safety PLC does not provide a suited test mode, you have to release the corresponding safety functions in your application and you have to check the reaction of the respective outputs.
- Examine a fully function test with the entire sensors (initiators), switches, actuators and drives.
- Document the result of the function test.
- To examine the function test you have to release all safety functions successively and you have to document the reaction of the system. Check whether the reaction corresponds to the expected behavior.



### 3.12 Operation



#### **DANGER!**

During operation of the safety PLC, no changes to the system configuration are allowed.

Therefore:

Before extending the system, removing individual system components and changing the wiring, the PLC system is basically be set into a safe state dependent on the application by professional personnel.



*For the operation the ambient data, which are specified in the technical data must be adhered to! Commissioning is only permitted after the acclimation of the System SLIO safety modules!*

#### **Instructions for operation**

Instructions for the operation of System SLIO standard system components like power supply, bus coupler, IO modules can be found in the according manual.

### 3.13 Maintenance



#### **CAUTION!**

Make sure by organizational measures that the interval for the repeat inspection of all system components is kept. ↪ *Chap. 1.17 'Functional safety - safety relevant parameters' page 17*

- With the System SLIO safety module there is no repeat test possible for the user.
- If you keep the prescribed environmental conditions (see technical data) the corresponding safety module is maintenance-free.
- If you determine or assume a defect on a safety module, please contact Yaskawa.

### 3.14 Repair



#### **CAUTION!**

Defective safety modules may only be repaired by the manufacturer.

A defective safety module cannot be repaired. Please contact Yaskawa for spare.

### 3.15 Diagnostics

#### **Requirements to the operating personnel**

The personnel, who works with the safety signal module, must be instructed in the safety regulations and the operation of the module to correctly operate it. In particular the reaction to error messages and states requires special knowledge which the operator must have. In the following you will find information about disturbances and the resulting error messages.

**Fail safe principle**

The module bases on the fail-safe principle. This means that each error automatically leads to a safety state (safety switched off outputs, every input reports off-circuit state).

**CAUTION!**

Do not switch a safety-related incorrect system to operating state again, as long as you do not know the cause of the error or an error has been corrected.

**Detecting errors in the periphery**

The electro-mechanical error detection is ensured by the input circuit. Electronic sensors must have an own error detection relating to a short-circuit on the output.

**3.15.1 Error response****Safe state**

The safety concept is based on the existence of a safe state at all process variables. For digital safety modules, this safe state is the value "0". This applies to sensors and actuators.

In safe condition the safety signal module safely switches off the outputs. Thus a control of the attached actuators is safely interrupted.

**Response to error and start-up of the safety-related system**

The safety function requires the use of substitute values (safe state) instead of process values for a safety-related signal module (passivation of safety-related signal module) in the following cases:

- during the start-up of the safety-related system
- when errors in safety-oriented communication between the F-CPU and safety module are detected by means of the PROFIsafe safety protocol (communication error)
- when peripheral or channel errors are detected (e.g. wire break, discrepancy error)

If possible errors are logged to the diagnostic buffer of the safety-related CPU and reported to the safety program of the safety-related CPU. Safety modules cannot store errors non volatile. After PowerOFF - PowerON during start-up a further existing error is again detected. You can make error storage however in your standard program.

**CAUTION!**

Channel errors do not trigger any diagnostic reactions or error handling for channels that have been set to "deactivated", even when this channel is affected indirectly by a channel group error ("Channel activated/ deactivated" parameter).

**Remedying faults in a safety-related system**

To remedy errors in your fail-safe system, proceed as described in EN 61508-1 Section 7.15.2.4 and EN 61508-2 Section 7.6.2.1 e. For remedy the following steps must be performed in a safety-related system:

1. ➤ Diagnosis and repair of the fault
2. ➤ Revalidation of the safety function
3. ➤ Recording in the service report

- Substitute value output for safety modules**
- If channels are passivated with safety DI modules, the safety-related system provides substitute values for the safety program instead of the process values applied to the safety-related inputs:
    - For safety DI modules, this is always the substitute value (0).
  - In the case of safety DO modules, if passivation occurs the safety-related system transfers substitute values (0) to the safety-related outputs instead of the output values provided by the safety program. The output channels are de-energized. This also applies when the safety-related CPU goes into STOP mode. You cannot program substitute values.
- Reintegration of a safety module**
- The system changes from substitute to process values (reintegration of a safety module) either automatically or only after user acknowledgement in the safety program. After reintegration:
- for a safety DI module the process values pending at the safety-related inputs are provided for the safety program.
  - for safety DO module the output values provided in the safety program are again transferred to the safety-related outputs.
- 🔗 *Chap. 3.18 'Sample application' page 122*
- Reaction of the inputs to communication errors**
- The safety modules with inputs respond differently to communication errors compared to other errors.
- If a communication error is detected, the current process values remain set at the inputs of the safety module and the channels are not passivated.
  - The current process values are sent to the safety-related CPU and are passivated in the safety-related CPU.
- Reaction of the safety modules on module failure**
- On a serious internal error in the safety module, which leads to a fault of the safety module:
- the connection to the backplane bus is interrupted and the safety-related I/Os are passivated.
  - Diagnostics are not transmitted from the safety module and the default diagnostic message "Module Fault" is reported.
  - the SF LED of the corresponding safety module is on.

### 3.15.2 Fault diagnostics

Diagnostics are used to determine whether error-free signal acquisition is taking place at the safety module. Diagnostics information is assigned either to a single channel or to the entire safety module. None of the diagnostic functions (displays and messages) are safety critical and therefore not designed to be safety-related functions. Consequently, they are not tested internally. The following diagnostic options are available for fail-safe modules:

- LED display on the module front
- Diagnostic functions of the safety modules (slave diagnostics in accordance with IEC 61784-1:2003).



#### **Behaviour on changes of the safe parametrization**

*If the safety program was not again generated and transferred to the F PLC after changing the safety parametrization, the System SLIO safety module does not report any error. Then the F PLC passivates the module and the inputs and outputs remain at 0.*

**ERR LED status in case of error**

On error the ERR LED shows an error by a corresponding blink behavior. ↪ *Chap. 2.3 'SDI 4xDC 24V - Operating and display elements' page 29*



*Thus diagnostic messages that persist only for a short time, also can be handled, you have to adapt the error handling in the corresponding error OB of your user program for example the diagnostic messages are stored in a data block.*

**SDI 4xDC 24V**

Error	Behavior of the diagnostic messages	Error recovery
Short circuit <ul style="list-style-type: none"> <li>■ The test pulses are no longer detected on the input.</li> <li>■ e.g. cross circuit to DV 24V</li> </ul>	Error is permanently reported.	Correct the wiring, sensor or configuration errors. Acknowledge the error and perform a power cycle.
Cross circuit <ul style="list-style-type: none"> <li>■ At an input the wrong test pulses are detected.</li> <li>■ e.g. wiring error.</li> </ul>	Error is permanently reported.	Correct the wiring error. Acknowledge the error and perform a power cycle.
Discrepancy error <ul style="list-style-type: none"> <li>■ The signal state of the dual-channel input does not match.</li> </ul>	The error is only a short time reported.	Correct the wiring, sensor or configuration error. Acknowledge the error and perform a power cycle.
The address switch for F-address was changed <ul style="list-style-type: none"> <li>■ The address switch and the configuration was changed.</li> <li>■ e.g. module replacement</li> </ul>	Error is permanently reported.	Change the F-address ↪ <i>Chap. 3.4.1 'Changing the F-address' page 76.</i> Perform a power cycle.
Other errors <ul style="list-style-type: none"> <li>■ Error in configuration</li> </ul>	Error is permanently reported.	Correct the configuration data such as a wrong F-address. Perform a power cycle.
Other errors <ul style="list-style-type: none"> <li>■ "Light" internal errors</li> </ul>	Error is permanently reported.	Perform a power cycle.
Other errors <ul style="list-style-type: none"> <li>■ "Heavy" internal errors</li> </ul>	An error can not be reported. The System SLIO Safety module switches into safe mode and then becomes inactive.	Perform a power cycle.

## SDO 4xDC 24V 0.5A

Error	Behavior of the diagnostic messages	Error recovery
Short circuit <ul style="list-style-type: none"> <li>■ The test pulses are no longer detected on the output.</li> <li>■ e.g. the set test pulse length is too small</li> </ul>	The error is only a short time reported since with disabling the output no more testing is possible.	Correct the wiring or configuration error. Acknowledge the error and perform a power cycle.
Cross circuit <ul style="list-style-type: none"> <li>■ At an output the wrong test pulses are detected.</li> <li>■ e.g. wiring error</li> </ul>	The error is only a short time reported since with disabling the output no more testing is possible.	Correct the wiring error. Acknowledge the error and perform a power cycle.
Wire break error <ul style="list-style-type: none"> <li>■ With enabled output, no current &gt; 30mA could be determined.</li> </ul>	The error is only a short time reported since with disabling the output no more testing is possible.	Correct the wiring or configuration error. Acknowledge the error and perform a power cycle.
Read back error of the output part <ul style="list-style-type: none"> <li>■ The target state does not match its current state.</li> <li>■ Either external power supply DC 24V and output should be 0 or external short circuit to ground and output should be 1.</li> </ul>	Error at external power supply is permanently reported. A short circuit or defect of the module is only a short time reported.	Correct the wiring error. Acknowledge the error and perform a power cycle.
The address switch for F-address was changed <ul style="list-style-type: none"> <li>■ The address switch and the configuration was changed.</li> <li>■ e.g. module replacement</li> </ul>	Error is permanently reported.	Change the F-address  <i>Chap. 3.4.1 'Changing the F-address' page 76.</i> Perform a power cycle.
Other errors <ul style="list-style-type: none"> <li>■ Error in configuration</li> </ul>	Error is permanently reported.	Correct the configuration data such as a wrong F-address. Perform a power cycle.
Other errors <ul style="list-style-type: none"> <li>■ "Light" internal errors</li> </ul>	Error is permanently reported.	Perform a power cycle.
Other errors <ul style="list-style-type: none"> <li>■ "Heavy" internal errors</li> </ul>	An error can not be reported. The System SLIO Safety module switches into safe mode and then becomes inactive.	Perform a power cycle.

**Configurable diagnostics functions**

Via the parametrization you may activate a diagnostic interrupt for the module. With a diagnostics interrupt the module serves for diagnostics data for diagnostic interrupt<sub>t<sub>incoming</sub></sub>. As soon as the reason for releasing a diagnostic interrupt is no longer present, the diagnostic interrupt<sub>t<sub>going</sub></sub> automatically takes place. Within this time window (1. diagnostic interrupt<sub>t<sub>incoming</sub></sub> until last diagnostic interrupt<sub>t<sub>going</sub></sub>) the MF-LED of the module is on.

For the following events the triggering of a diagnostic message depends on the parametrization of the System SLIO safety module:

- for safety DI module short- and cross-circuit monitoring
- for safety DO module wire-break detection

**CAUTION!**

Diagnostic functions should be activated or deactivated in accordance with the application.

↪ *Chap. 2.5 'SDI 4xDC 24V - FSoE Parameter record set' page 36*

↪ *Chap. 2.9 'SDO 4xDC 24V 0.5A - FSoE Parameter record set' page 52*

**3.15.2.1 Diagnostic data**

With EtherCAT the access happens via the CoE objects:

- 0x5002: Access to the first 4byte of diagnostic data.
- 0x5005: Access to all diagnostic data (20byte).

Name	Bytes	Function	Default
ERR_A	1	Diagnostic	00h
MODTYP	1	Module information	18h
ERR_B	1	reserved	00h
ERR_C	1	Module internal error	00h
CHTYP	1	Channel type	30h/31h
NUMBIT	1	Number diagnostics bits per channel	08h
NUMCH	1	Number channels of the module	04h
CHERR	1	Channel error	00h
CH0ERR	1	Channel-specific error channel 0	00h
CH1ERR	1	Channel-specific error channel 1	00h
CH2ERR	1	Channel-specific error channel 2	00h
CH3ERR	1	Channel-specific error channel 3	00h
ERR_D	1	Module-specific error	00h
ERR_E	1	reserved	00h
ERR_F	1	reserved	00h
ERR_G	1	reserved	00h
DIAG_US	4	µs ticker	00h

**ERR\_A - Diagnostic**

Byte	Bit 7 ... 0
0	<ul style="list-style-type: none"> <li>■ Bit 0: set at module failure</li> <li>■ Bit 1: reserved</li> <li>■ Bit 2: set at external error</li> <li>■ Bit 3: set at channel error</li> <li>■ Bit 4: set at external auxiliary supply missing</li> <li>■ Bit 6 ... 5: reserved</li> <li>■ Bit 7: set at error in parameterization</li> </ul>

**MODTYP - Module information**

Byte	Bit 7 ... 0
0	<ul style="list-style-type: none"> <li>■ Bit 3 ... 0: Module class <ul style="list-style-type: none"> <li>– 1000b safety-related digital module</li> </ul> </li> <li>■ Bit 4: set at channel information present</li> <li>■ Bit 7 ... 5: reserved</li> </ul>

**CHTYP - Channel type**

Byte	Bit 7 ... 0
0	<ul style="list-style-type: none"> <li>■ Bit 6 ... 0: Channel type <ul style="list-style-type: none"> <li>– 30h: safety-related DI module</li> <li>– 31h: safety-related DO module</li> </ul> </li> <li>■ Bit 7: reserved</li> </ul>

**NUMBIT - Diagnostic bits**

Byte	Bit 7 ... 0
0	Number of diagnostic bits per channel (here 08h)

**NUMCH - Channels**

Byte	Bit 7 ... 0
0	Number of channels of a module (here 04h)

**CHERR - Channel error**

Byte	Bit 7 ... 0
0	<ul style="list-style-type: none"> <li>■ Bit 0: set at error in channel 0</li> <li>■ Bit 1: set at error in channel 1</li> <li>■ Bit 2: set at error in channel 2</li> <li>■ Bit 3: set at error in channel 3</li> <li>■ Bit 7 ... 4: reserved</li> </ul>

**CH0ERR ... CH3ERR - Channel-specific**

Byte	Bit 7 ... 0
0	Channel-specific error: Channel x: <ul style="list-style-type: none"> <li>■ Bit 0: set at short circuit to DC 24V</li> <li>■ Bit 1: set at short circuit to ground</li> <li>■ Bit 2: set at wire-break</li> <li>■ Bit 3: set at cross-circuit</li> <li>■ Bit 4: set at discrepancy error</li> <li>■ Bit 7 ... 5: reserved</li> </ul>

## Packing and transport

## ERR\_C - Module-internal

Byte	Bit 7 ... 0
0	Module-internal error: <ul style="list-style-type: none"> <li>■ Bit 3 ... 0: reserved</li> <li>■ Bit 4: set at a communication error on the System SLIO safety module</li> <li>■ Bit 7 ... 5: reserved</li> </ul>

## ERR\_D - Module-specific

Byte	Bit 7 ... 0
0	Module-specific error <ul style="list-style-type: none"> <li>■ Bit 3 ... 0: reserved</li> <li>■ Bit 4: set at error in I parameter</li> <li>■ Bit 5: set at error in F parameter</li> <li>■ Bit 6: set if the F-address set by the F-address switch, does not fit to the F-address stored in the EEPROM.</li> <li>■ Bit 7: set if the F-address in the EEPROM was reset.</li> </ul>



*If the change process of the F-address is initiated by the configured record set, then bit 7 of ERR\_D is set.*

*If the re-parameterization happens by means of the F-address switch setting 0...0, the reset function of the bus device during start-up can possibly prevent that this bit is reported.*

DIAG\_US -  $\mu$ s ticker

Byte	Bit 7 ... 0
0 ... 3	Value of the System SLIO $\mu$ s ticker at the moment of the diagnostic

 $\mu$ s ticker

In the SLIO module there is a timer ( $\mu$ s ticker). With PowerON the timer starts counting with 0. After  $2^{32}-1\mu$ s the timer starts with 0 again.

## ERR\_B, E, F, G - reserved

Byte	Bit 7 ... 0
0	reserved

### 3.16 Packing and transport

#### Packing

Each device was packaged before in a way, that makes becoming damaged while on transport very unlikely.

#### Transport

The units are packed at the factory in accordance with the order.

- Avoid heavy shaking while on transport and severe bumping.
- Avoid electrostatic discharge on the electronic components of the modules.
- Take the module until immediately before installation out of the protective packaging.
- If you have to transport the module later, please consider the following:
  - use the original packaging or
  - use a appropriate packaging for ESD sensitive components.
- Make sure that the transportation conditions "Approvals, directives, standards" during the entire transport are met. ↪ *Chap. 1.18 'Approvals, directives, standards' page 19*



**Unpacking**

After delivery of the still packaged item check if there are visible transportation damages. If yes report this to your deliverer. Request a written confirmation of your reclamation and make immediate contact with you local Yaskawa representation.

**DANGER!****Risk by electrostatic discharge**

If you expose the module, particularly its electronic components to electrostatic discharge by touching with the hand, the module can be damaged or destroyed completely.

- Consider in handling the module the regulations and references to handling electrostatic sensitive components.
- If you recognize a transport damage or the delivery is not complete, you have to complain at the appropriate Yaskawa representative.

If there is no transport damage visible:

- Open the packaging of the device.
- Check the scope of delivery by means of the delivery note.

**Scope of delivery**

- System SLIO signal module
- Manual incl. conformity / manufacturer declaration

**Disposal of packaging**

The packaging consists of cardboard and / or plastic. Please observe the local disposal regulations, if you discard the packaging.

**3.17 Storage and disposal****Storage conditions**

Store the safety module in an appropriate packaging and to the storage conditions, mentioned in "Approvals, directives, standards". ↪ *Chap. 1.18 'Approvals, directives, standards' page 19*

**Shipping**

For shipping always use the original packaging.

**Disposal**

In principle the disposal takes place via Yaskawa. Send defective and/or to be disposed System SLIO safety modules to Yaskawa.

**Demands on the personnel**

The personnel which you instruct to demount devices must have the knowledge and training to carry out these jobs properly.

Choose the personnel in a way that it is secured that safety information are understood and observed.

### 3.18 Sample application

#### 3.18.1 Precondition

##### Hardware and software

This application example describes the use of the System SLIO safety modules with EtherCAT. The following hardware and software is required for the example:



*Please note that the FSoE Master safety configuration tool listed here is an example and is intended to clarify the procedures. Please use the safety configuration tool associated with your FSoE master.*

Hardware	Device / module	Designation / order number
Central unit	System SLIO CPU with EtherCAT master	CPU 015-CEFNR00
FSoE master system	Power supply	SIS 800 FSoE master by ISH Ingenieursozietät GmbH
	Fieldbus modules	
	CPU master	
	CPU slave	
FSoE slave system	System SLIO Bus coupler	IM 053EC Slave (053-1EC01)
	System SLIO AO	SM 032 AO 4x12Bit (032-1BD40)
	System SLIO AI	SM 031 AI 4x12Bit (031-1BD40)
	System SLIO Safety DI	SM 021 (021-1SD10)
	System SLIO Safety DO	SM 022 (022-1SD10)
	System SLIO DI	SM 021 (021-1BD10)
	System SLIO DO	SM 022 (022-1BD00)
Switch	Relay	DC 24V relay with two changeover contacts (e.g. Finder type 40.52 with base 95.95.3)
	Switch	Switch as closer

Software	Tool
Programming software	Siemens SIMATIC Manager
Configuration tool EtherCAT	SPEED7 EtherCAT Manager
Configuration tool FSoE master	Use the safety configuration tool associated with your FSoE master.

**F-addresses**

Before installing the following modules, set the corresponding F-address using the DIP switch:

Module	F-address decimal	Switch setting
System SLIO 021-1SD10	1	0000 0000 0001
System SLIO 022-1SD10	2	0000 0000 0010

**Hardware structure**

Build the application example according to the following illustration:

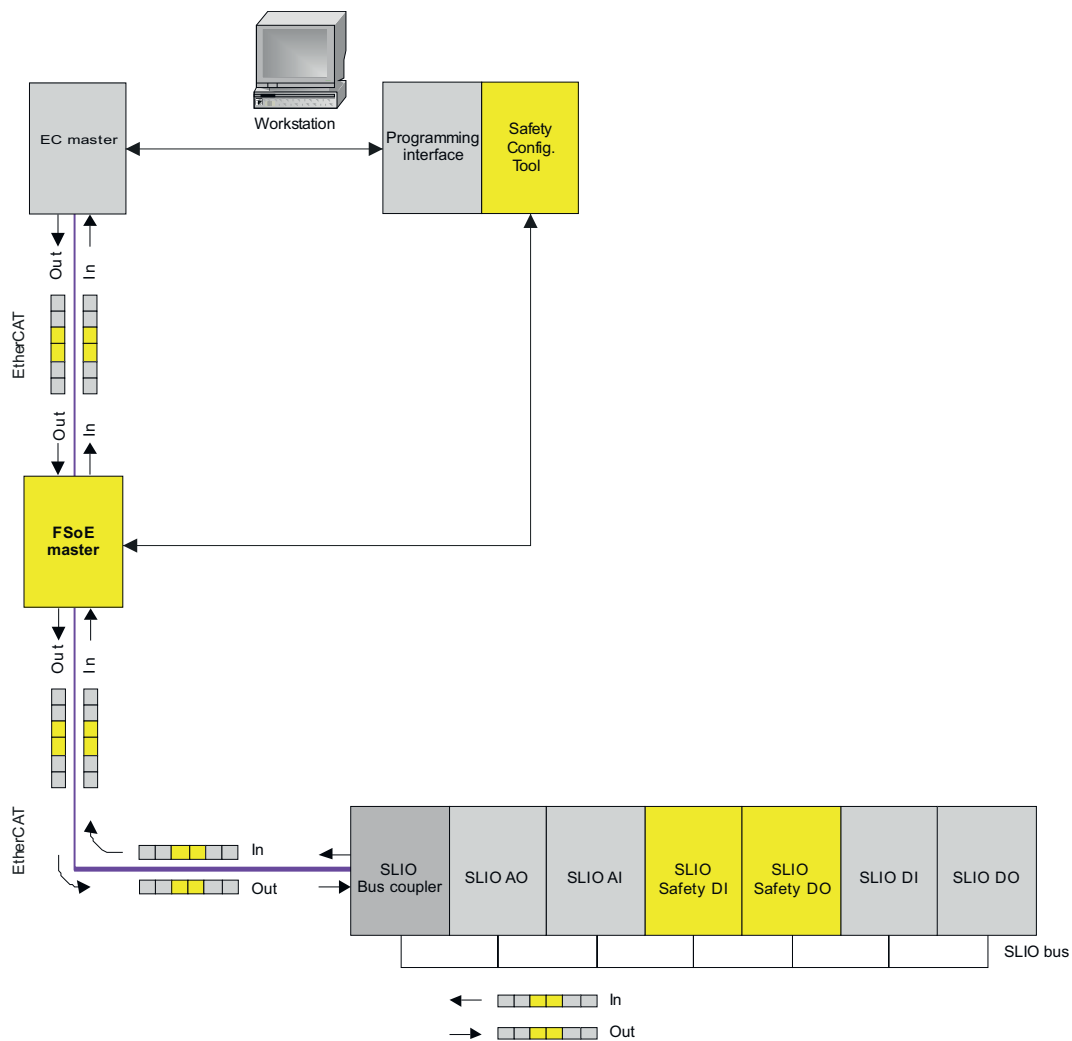

**Wiring**

Build the application example according to the following illustration:

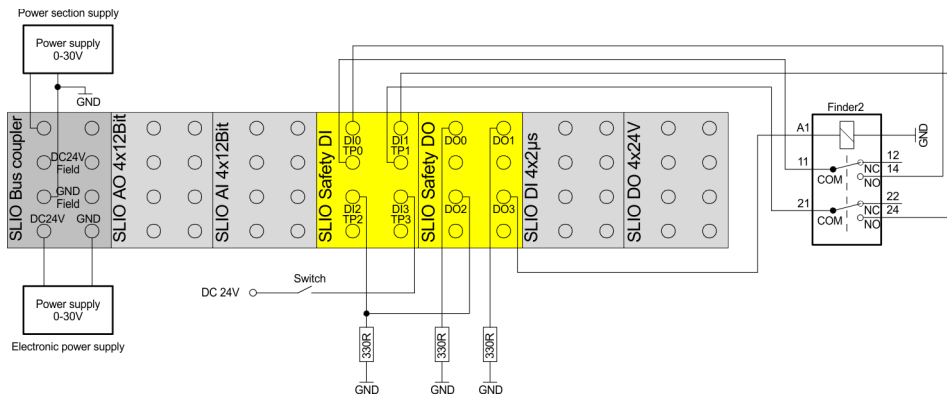

**3.18.2 Configuration in the safety configuration tool**

**Proceeding**

The safety configuration tool used here is an example and serves to clarify the procedures. Please use the safety configuration tool associated with your FSoE master.

1. ➤ Open your safety configuration tool for the FSoE master.
2. ➤ Use the corresponding button to create a new project.
3. ➤ Enter a project name in the 'Project wizard'. Leave the 'Project path' unchanged.

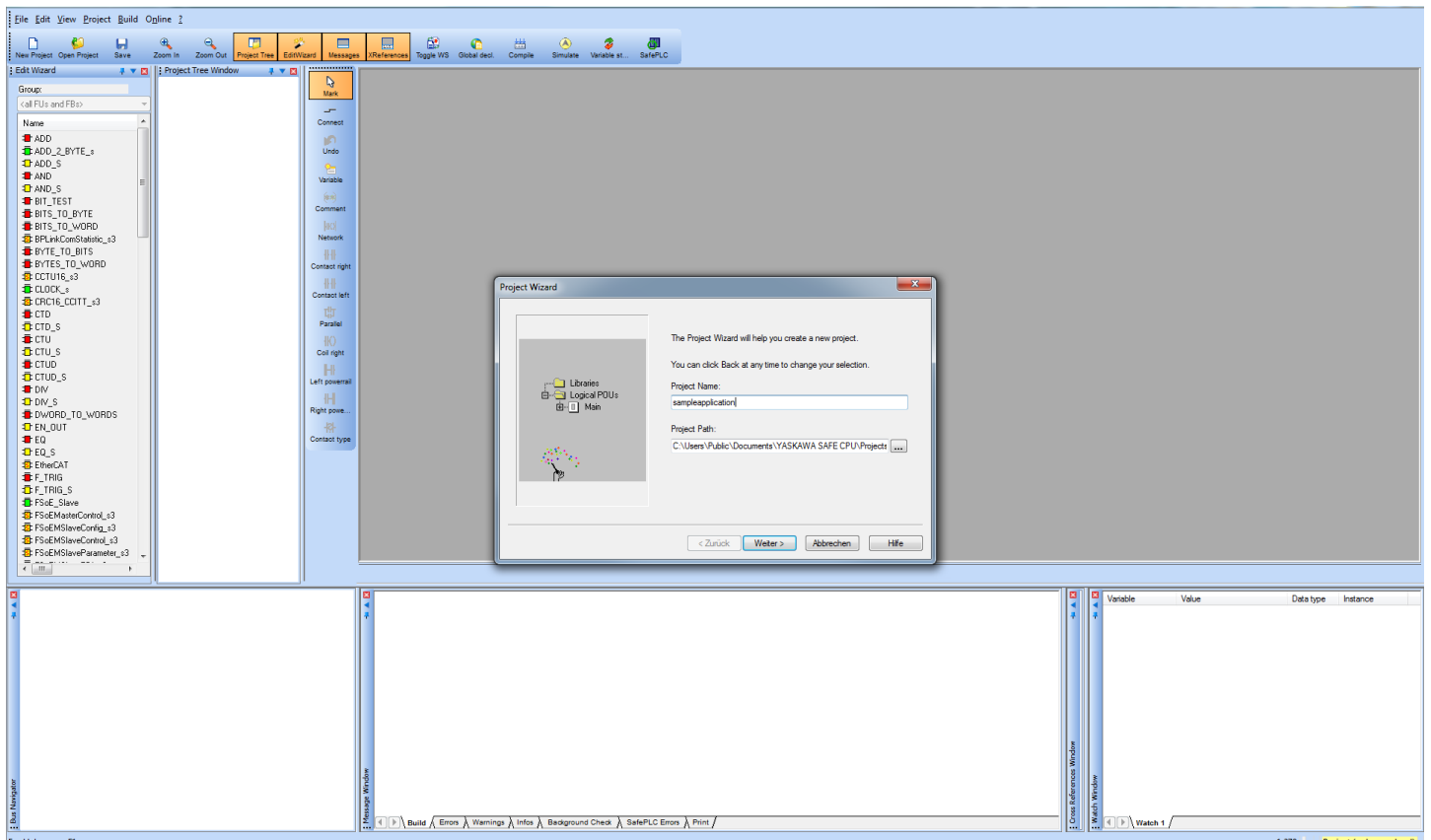

4. ➤ Confirm a new bus structure in the next dialog window.
  - ⇒ The dialog window for assigning the password opens.

5. ➤ Assign passwords for 'Development' and 'Commissioning' here.

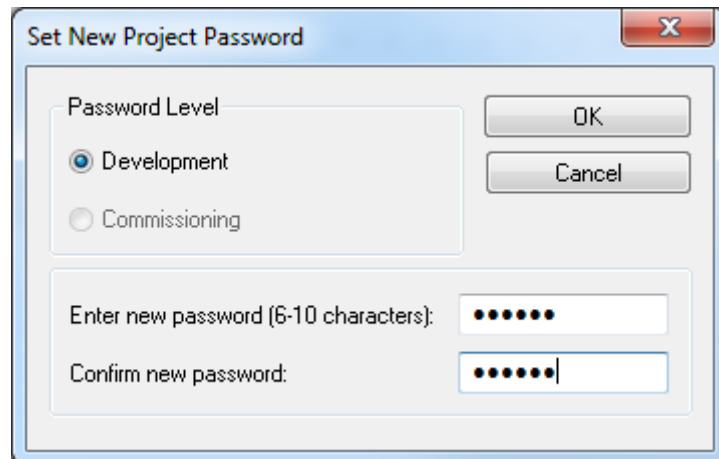

The dialog box 'Set New Project Password' has a close button (X) in the top right corner. It contains two radio buttons under 'Password Level': 'Development' (selected) and 'Commissioning'. Below these are two text input fields: 'Enter new password (6-10 characters):' and 'Confirm new password:'. Both fields contain masked characters (dots). 'OK' and 'Cancel' buttons are located to the right of the radio buttons.

6. ➤ Open the *FSoE Bus Configurator*. First install the corresponding ESI<sub>FSoE-Slave</sub> here via 'Device → Import Slave ESI file'.
7. ➤ Create the configuration of the System SLIO safety modules via drag & drop.

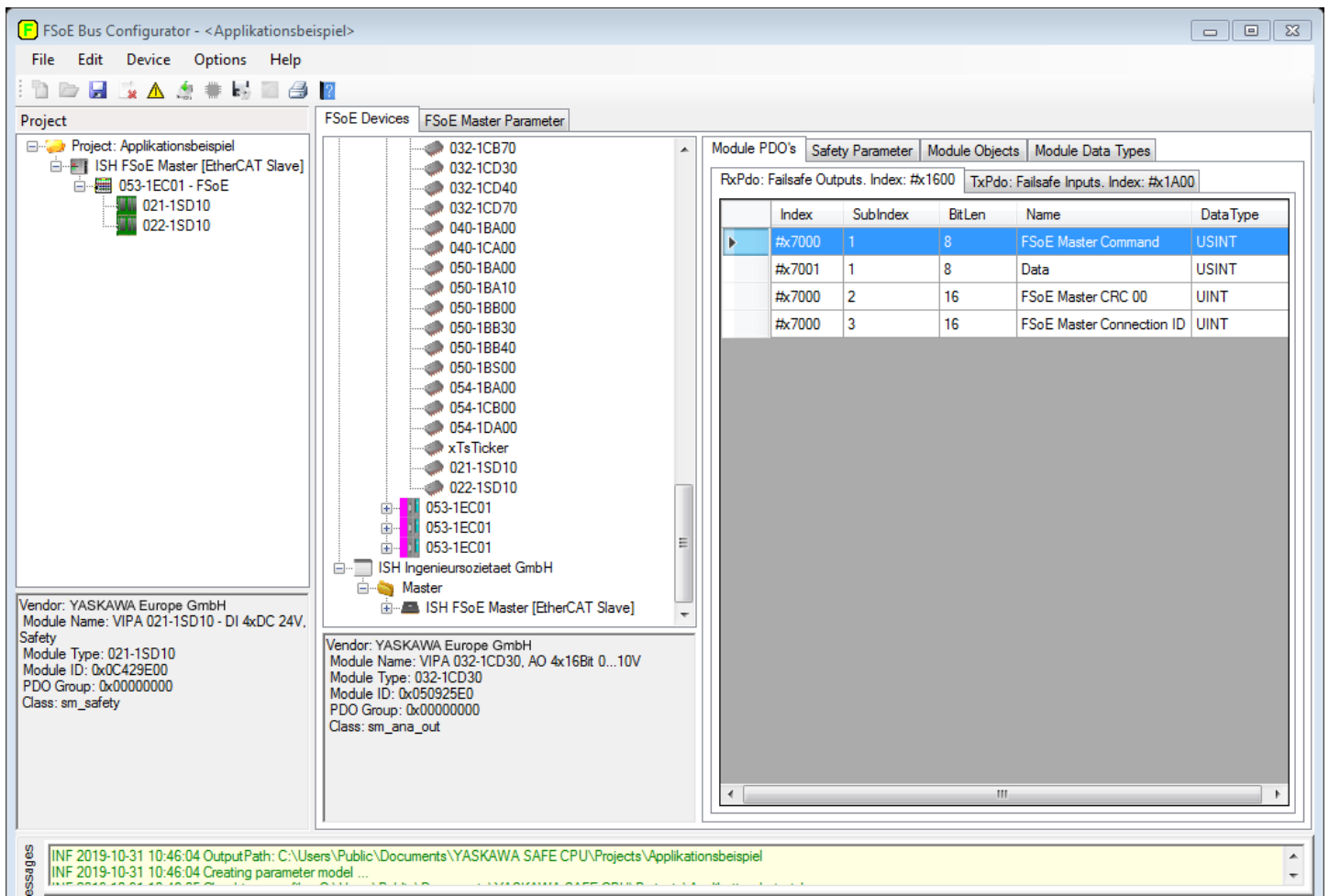

The screenshot shows the 'FSoE Bus Configurator' interface. The 'Project' tree on the left shows a project named 'Applikationsbeispiel' containing an 'ISH FSoE Master [EtherCAT Slave]' and two 'FSoE' modules (053-1EC01, 021-1SD10, 022-1SD10). The 'FSoE Devices' list in the center shows a hierarchy of modules including YASKAWA modules (032-1CB70 to 054-1DA00), xTs Ticker, and the installed slave modules (053-1EC01, 021-1SD10, 022-1SD10). The 'FSoE Master Parameter' tab is active, showing details for the selected slave module: Vendor: YASKAWA Europe GmbH, Module Name: VIPA 032-1CD30, AO 4x16Bit 0...10V, Module Type: 032-1CD30, Module ID: 0x050925E0, PDO Group: 0x00000000, Class: sm\_ana\_out. The 'Module PDO's' tab is also visible, showing a table of PDOs for the selected module.

Index	SubIndex	BitLen	Name	Data Type
#x7000	1	8	FSoE Master Command	USINT
#x7001	1	8	Data	USINT
#x7000	2	16	FSoE Master CRC 00	UINT
#x7000	3	16	FSoE Master Connection ID	UINT

The status bar at the bottom shows messages: 'INF 2019-10-31 10:46:04 OutputPath: C:\Users\Public\Documents\YASKAWA SAFE CPU\Projects\Applikationsbeispiel' and 'INF 2019-10-31 10:46:04 Creating parameter model ...'.

Sample application > Configuration in the safety configuration tool

8. The module parameters are then set in the 'FsoE Master Parameter' area and verified with 'Accept'.

The screenshot shows the 'FSoE Bus Configurator' software interface. The main window displays a table of parameters for 'Slave 1' under the 'FSoE Master Parameter' tab. The table has columns for No., Name, Value, Unit, Min, Max, Type, and Committed. The 'Committed' column contains checkboxes, many of which are checked and labeled 'Accept'. A right-hand panel shows 'Module' selection with '021-1SD10 Slave 1' selected and an 'Accept All' button. A messages window at the bottom shows log entries for parameter commitments.

No.	021-1SD10 Slave 1	Value	Unit	Min	Max	Type	Committed
1	Slave 1: FSoE Master Data Length	1	byte	1	65535	UInt	<input checked="" type="checkbox"/> Accept
2	Slave 1: FSoE Slave Data Length	1	byte	1	65535	UInt	<input checked="" type="checkbox"/> Accept
3	Slave 1: FSoE Connection ID	1	-	1	65535	UInt	<input checked="" type="checkbox"/> Accept
4	Slave 1: FSoE Address	0x1	-	0x1	0xFFFF	UInt	<input checked="" type="checkbox"/> Accept
5	Slave 1: FSoE PD Read Offset	0	byte	0	65535	UInt	<input checked="" type="checkbox"/> Accept
6	Slave 1: FSoE PD Write Offset	0	byte	0	65535	UInt	<input checked="" type="checkbox"/> Accept
7	Slave 1: ComParameterLength	2	-	0	65535	UInt	<input checked="" type="checkbox"/> Accept
8	Slave 1: Watchdog Time	500	-	0	65535	UInt	<input checked="" type="checkbox"/> Accept
9	Slave 1: AppParameterLength	16	-	16	16	UInt	<input checked="" type="checkbox"/> Accept
10	Slave 1: Version ID	0	-	0	65535	UInt	<input checked="" type="checkbox"/> Accept
11	Slave 1: Module type ID	0	-	0	4294967295	UInt	<input checked="" type="checkbox"/> Accept
12	Slave 1: Ch0.1: Re-integration after discrepancy fault	0	-	0	1	Bool	<input checked="" type="checkbox"/> Accept
13	Slave 1: Ch0.1: Signal polarity	0	-	0	1	Bool	<input checked="" type="checkbox"/> Accept
14	Slave 1: Ch0.1: Input evaluation	1	-	0	1	Bool	<input checked="" type="checkbox"/> Accept
15	Slave 1: Ch0.1: Test pulse activation	1	-	0	1	Bool	<input checked="" type="checkbox"/> Accept
16	Slave 1: Ch0.1: Activation	1	-	0	1	Bool	<input type="checkbox"/> Accept
17	Slave 1: Alignment 1	0	bit	0	0	UInt	<input type="checkbox"/> Accept
18	Slave 1: Ch2.3: Re-integration after discrepancy fault	0	-	0	1	Bool	<input type="checkbox"/> Accept
19	Slave 1: Ch2.3: Signal polarity	0	-	0	1	Bool	<input type="checkbox"/> Accept
20	Slave 1: Ch2.3: Input evaluation	0	-	0	1	Bool	<input type="checkbox"/> Accept
21	Slave 1: Ch2.3: Test pulse activation	1	-	0	1	Bool	<input type="checkbox"/> Accept
22	Slave 1: Ch2.3: Activation	1	-	0	1	Bool	<input type="checkbox"/> Accept
23	Slave 1: Parameter change mode	0	-	0	1	Bool	<input type="checkbox"/> Accept
24	Slave 1: Diagnostic Interrupt	1	-	0	1	Bool	<input type="checkbox"/> Accept
25	Slave 1: Behaviour after Channel Errors	0	-	0	1	Bool	<input type="checkbox"/> Accept
26	Slave 1: Ch0.1: Input signal-smoothing [ms]	3	-	0	65535	UInt	<input type="checkbox"/> Accept
27	Slave 1: Ch0.1: Discrepancy timeout [ms]	20	-	0	65535	UInt	<input type="checkbox"/> Accept
28	Slave 1: Ch2.3: Input signal-smoothing [ms]	5	-	0	65535	UInt	<input type="checkbox"/> Accept
29	Slave 1: Ch2.3: Discrepancy timeout [ms]	15	-	0	65535	UInt	<input type="checkbox"/> Accept

Messages:

```

INF 2019-10-31 11:23:00 <Slave 1: Ch0.1: Re-integration after discrepancy fault>: Committed value 0
INF 2019-10-31 11:23:01 <Slave 1: Ch0.1: Signal polarity>: Committed value 0
INF 2019-10-31 11:23:01 <Slave 1: Ch0.1: Input evaluation>: Committed value 1
INF 2019-10-31 11:23:02 <Slave 1: Ch0.1: Test pulse activation>: Committed value 1
    
```

**FSoE Bus Configurator - <Applikationsbeispiel>**

File Edit Device Options Help

Project: Applikationsbeispiel

- ISH FSoE Master [EtherCAT Slave]
  - 053-1EC01 - FSoE
    - 021-1SD10
      - 022-1SD10

Project file: Applikationsbeispiel  
Description: Applikationsbeispiel  
Version: 0  
Checksum:  
Master Device: FSoE Master Device  
Module: FSoE Master Module  
UUID: 29366ac-6153-4c2c-a68d-447c72920a23  
User Name: DNenn

No.	022-1SD10 Slave 2	Value	Unit	Min	Max	Type	Committed
1	Slave 2: FSoE Master Data Length	1	byte	1	65535	UInt	Accept
2	Slave 2: FSoE Slave Data Length	1	byte	1	65535	UInt	Accept
3	Slave 2: FSoE Connection ID	2	-	1	65535	UInt	Accept
4	Slave 2: FSoE Address	0x2	-	0x1	0xFFFF	UInt	Accept
5	Slave 2: FSoE PD Read Offset	6	byte	0	65535	UInt	Accept
6	Slave 2: FSoE PD Write Offset	6	byte	0	65535	UInt	Accept
7	Slave 2: ComParameterLength	2	-	0	65535	UInt	Accept
8	Slave 2: Watchdog Time	500	-	0	65535	UInt	Accept
9	Slave 2: ApplParameterLength	16	-	16	16	UInt	Accept
10	Slave 2: Version ID	0	-	0	65535	UInt	Accept
11	Slave 2: Module type ID	0	-	0	4294967295	UInt	Accept
12	Slave 2: Ch0: Wire break recognition	1	-	0	1	Bool	Accept
13	Slave 2: Ch1: Wire break recognition	1	-	0	1	Bool	Accept
14	Slave 2: Ch0.1: Activation mode	1	-	0	1	Bool	Accept
15	Slave 2: Ch0.1: Activation	1	-	0	1	Bool	Accept
16	Slave 2: Ch2: Wire break recognition	0	-	0	1	Bool	Accept
17	Slave 2: Ch3: Wire break recognition	0	-	0	1	Bool	Accept
18	Slave 2: Ch2.3: Activation mode	0	-	0	1	Bool	Accept
19	Slave 2: Ch2.3: Activation	1	-	0	1	Bool	Accept
20	Slave 2: Alignment 1	0	bit	0	0	UInt	Accept
21	Slave 2: Parameter change mode	0	-	0	1	Bool	Accept
22	Slave 2: Diagnostic Interrupt	1	-	0	1	Bool	Accept
23	Slave 2: Alignment 2	0	bit	0	0	UInt	Accept
24	Slave 2: Ch0: Test pulse length [us]	1000	-	0	65535	UInt	Accept
25	Slave 2: Ch1: Test pulse length [us]	1500	-	0	65535	UInt	Accept
26	Slave 2: Ch2: Test pulse length [us]	750	-	0	65535	UInt	Accept
27	Slave 2: Ch3: Test pulse length [us]	2000	-	0	65535	UInt	Accept

Module: 021-1SD10 Slave 1, 022-1SD10 Slave 2

Accept All

Messages: [INF 2019-10-31 11:24:58 <Slave 2: Ch0: Test pulse length [us]>- Committed value 1000  
[INF 2019-10-31 11:24:58 <Slave 2: Ch1: Test pulse length [us]>- Committed value 1500  
[INF 2019-10-31 11:24:58 <Slave 2: Ch2: Test pulse length [us]>- Committed value 750  
[INF 2019-10-31 11:24:58 <Slave 2: Ch3: Test pulse length [us]>- Committed value 2000

9. Then proceed as follows by clicking on the corresponding buttons: [Validate Parameter], [Safe Project], [Export Safe Container], [Export FsoE Master ESI-File].

⇒ The configuration of the safety program is created and exported as an ESI<sub>FSoE master</sub>, which is required for configuration in the *SPEED7 EtherCAT Manager*.

10. Close the *FSoE Bus Configurator*.

Sample application > Configuration in the safety configuration tool

11. Now program your application in your safety configuration tool according to the following template:

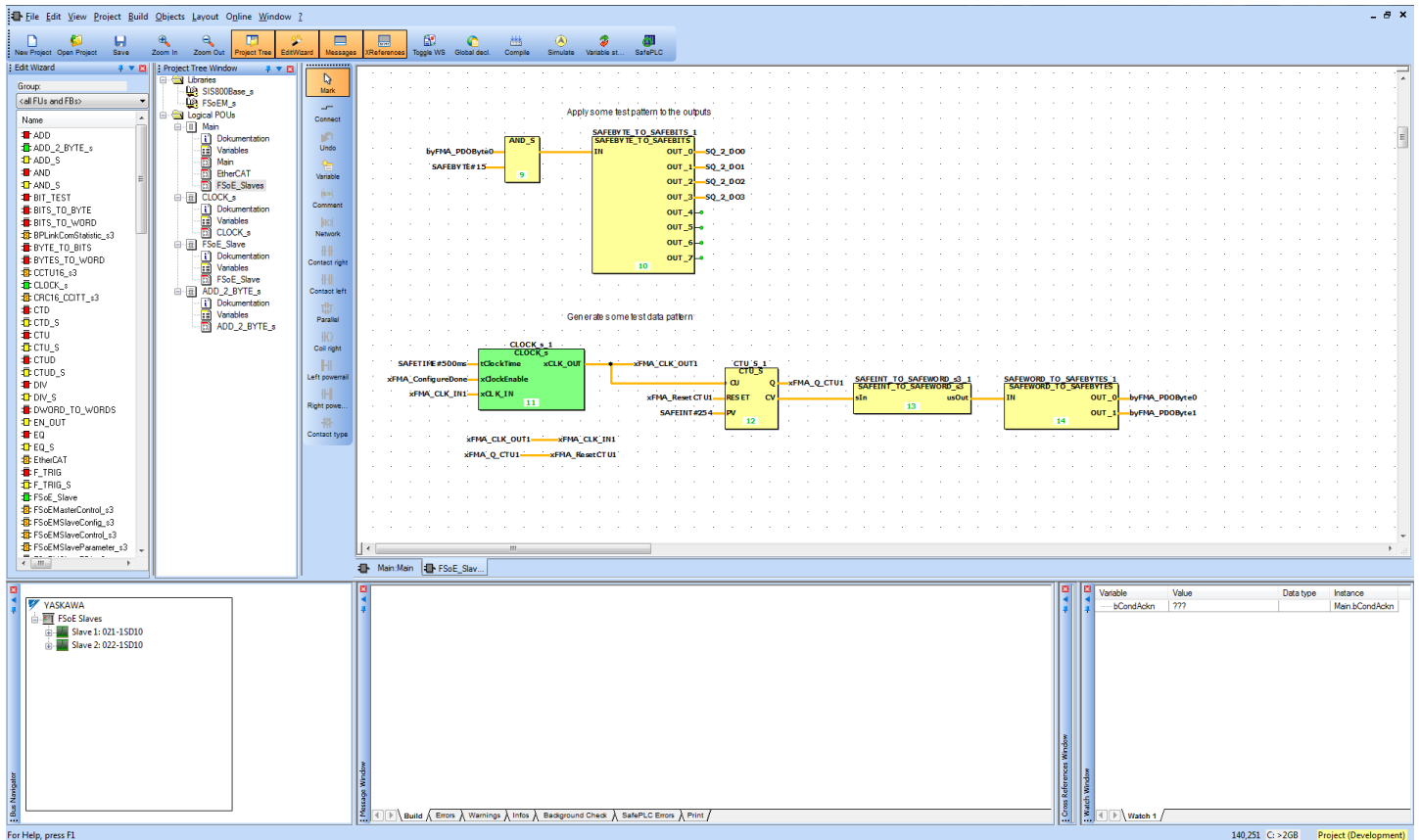

12. Compile and save the project via the corresponding buttons.
13. Bring your FSoE master online.
14. Select the safety PLC.
  - ⇒ After entering the password and asking for time synchronization between the PC and the FSoE master, the following window opens:



15. Click at [Debug].
  - ⇒ The FSoE master switches to *Debug mode*.
16. Click at [Stop].
  - ⇒ The FSoE master switches to *Stop mode* and is ready to receive data.



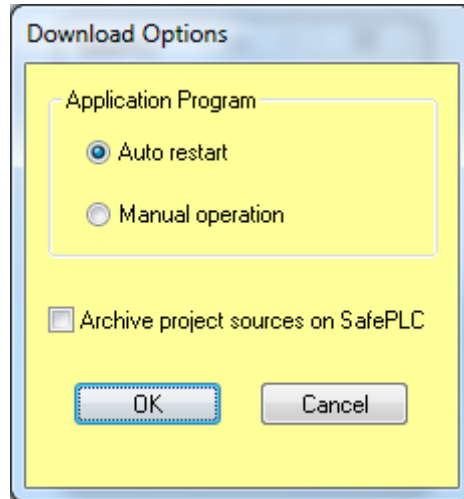

17. Click [Download] and confirm the download options.

⇒ The project is transferred to the FSoE master. Then close the safety configuration tool.

### 3.18.3 Configuration in the Siemens SIMATIC Manager and SPEED7 EtherCAT Manager

#### Proceeding

1. Create a new project with a SIMATIC 300 station in the Siemens SIMATIC Manager.
2. Perform a hardware configuration for the System SLIO CPU 015-CEFNR00. More details can be found in the corresponding manual for your CPU.
3. Configure the Ethernet PG/OP channel for the System SLIO CPU 015-CEFNR00. More details can be found in the corresponding manual for your CPU.
4. Configure the EtherCAT network for the System SLIO CPU 015-CEFNR00. More details can be found in the corresponding manual for your CPU.

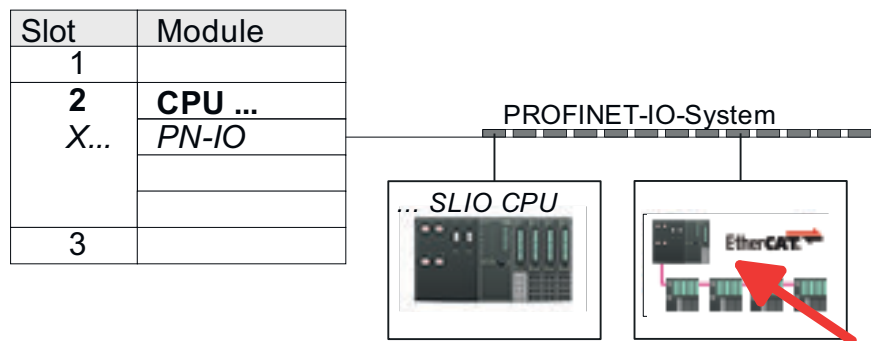

5. Click at the 'EtherCAT Network' and select 'Context menu → Start Device-Tool → SPEED7 EtherCAT Manager'".
 

⇒ The *SPEED7 EtherCAT Manager* opens.
6. Install the ESI files  $ESI_{\text{FSoE master}}$  and  $ESI_{\text{FSoE slave}}$  here via 'File → ESI manager'. The  $ESI_{\text{FSoE slave}}$  must be installed if the corresponding modules are not available in the hardware catalog.

7. ➤ Go online via the Ethernet PG/OP channel of the System SLIO CPU and read the hardware structure via 'Network ➔ Scan EtherCAT network'.

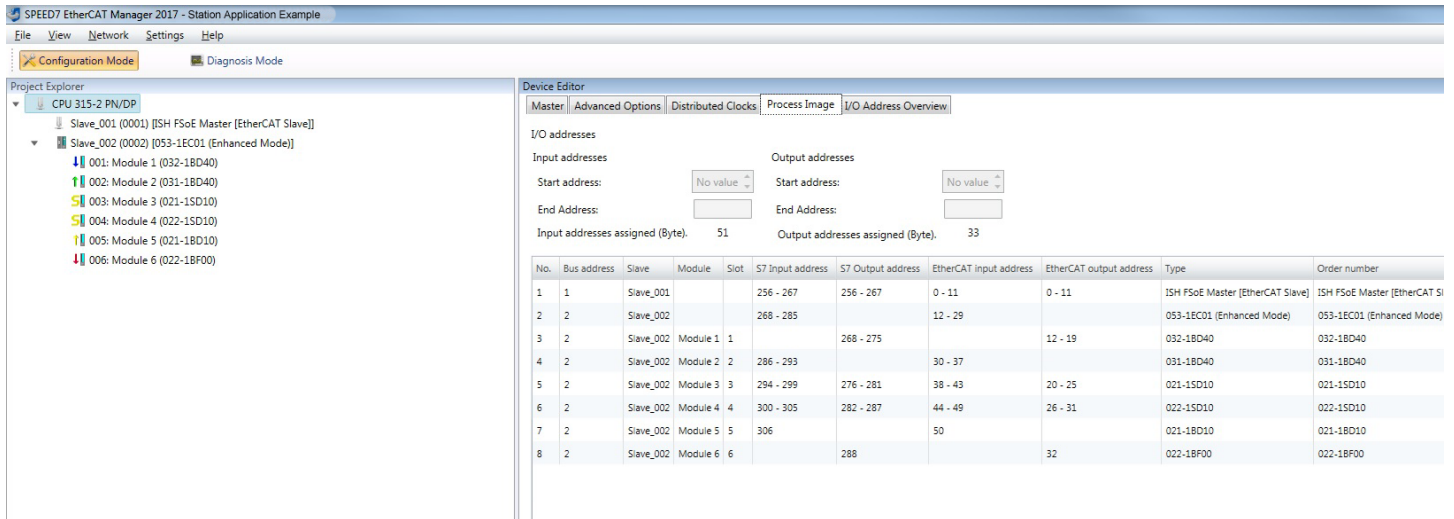

8. ➤ Now you can close the *SPEED7 EtherCAT Manager* and confirm the save project dialog box with [Yes].
  - ⇒ The *SPEED7 EtherCAT Manager* is closed and the configuration is applied to the project.
9. ➤ Select 'Station ➔ Save and compile'
10. ➤ Now you can close the hardware configurator.

- 11.** Create an FC 1 in the Siemens SIMATIC Manager. This is to ensure that the I/O data between FSoE master and System SLIO CPU are copied in each case.

```
Network 1: SDI -> FSoE-Master
L   EB   294; // FSoESlave Command
T   AB   256;
L   EB   295; // Data
T   AB   257;
L   EW   296; // FSoESlave CRC 0
T   AW   258;
L   EW   298; // FSoESlave ConnectionID
T   AW   260;

Network 2: SDO -> FSoE-Master
L   EB   300; // FSoESlave Command
T   AB   262;
L   EB   301; // Data
T   AB   263;
L   EW   302; // FSoESlave CRC 0
T   AW   264;
L   EW   304; // FSoESlave ConnectionID
T   AW   266;

Network 3: FSoE-Master -> SDI
L   EB   256; // FSoEMaster Command
T   AB   276;
L   EB   257; // Data
T   AB   277;
L   EW   258; // FSoEMaster CRC 0
T   AW   278;
L   EW   260; // FSoEMaster ConnectionID
T   AW   280;

Network 4: FSoE-Master -> SDO
L   EB   262; // FSoEMaster Command
T   AB   282;
L   EB   263; // Data
T   AB   283;
L   EW   264; // FSoEMaster CRC 0
T   AW   284;
L   EW   266; // FSoEMaster ConnectionID
T   AW   286;
```

- 12.** Include FC 1 in OB 1 for the cyclic call.
- 13.** Create the operation blocks OB 57 and OB 82 for error handling. These do not have to be programmed.
- 14.** Select '*Station → Save and compile*' and transfer the project to the System SLIO CPU via the Ethernet PG/OP channel.
- 15.** To activate the project, execute a STOP/RUN transition of the CPU.  
⇒ You have now created an executable security program.

### 3.18.4 Modifications

#### Changing the F-address

1. ➤ Switch off the 24V DC power supply for your System SLIO and disassemble the corresponding System SLIO safety module.
2. ➤ Switch all the switches of the F-address switch to 0 position.
3. ➤ Mount the System SLIO safety module and switch on the DC 24V power supply for your System SLIO, again.
4. ➤ Wait 5s and then switch off the 24V DC power supply again.  
⇒ The internal F-address memory of the System SLIO safety module is cleared.
5. ➤ Disassemble the System SLIO safety module again and set a new F-address at the F-address switch, e.g. 3 (switch position 0000 0000 0011).
6. ➤ Mount the System SLIO safety module and switch on the DC 24V power supply for your System SLIO safety module, again.
7. ➤ Open your safety configuration tool with the project for the application example.
8. ➤ Select the '*FSoE Bus Configurator*' and enter for the according System SLIO safety modul at '*FSoE master parameter*' area at parameter '*Slave ...: FSoE Address*' the new F-address e.g. 3.
9. ➤ Then proceed as follows by clicking on the corresponding buttons: [Validate Parameter], [Safe Project] and [Export Safe Container].
10. ➤ Close the '*FSoE Bus Configurator*'.
11. ➤ Compile and save the project using the corresponding buttons and transfer it to the safety controller of the FSoE master.  
⇒ You now have an executable security program with a changed F-address.

#### Change parameters

1. ➤ Open your safety configuration tool with the project for the application example.
2. ➤ Select the '*FSoE Bus Configurator*' and make the required parameter changes in the '*FSoE master parameter*' area for the corresponding System SLIO safety modul.
3. ➤ Validate the parameter changes by activating the associated '*Accept*' in the parameter table.
4. ➤ Then proceed as follows by clicking on the corresponding buttons: [Safe Project] and [Export Safe Container].
5. ➤ Close the '*FSoE Bus Configurator*'.
6. ➤ Compile and save the project using the corresponding buttons and transfer it to the safety controller of the FSoE master.  
⇒ You now have an executable safety program with modified safety module parameters.

## Appendix

## Contents

<b>A</b>	<b>Checklist planning.....</b>	<b>135</b>
<b>B</b>	<b>Checklist installation.....</b>	<b>136</b>
<b>C</b>	<b>Checklist commissioning, parameterization and validation.....</b>	<b>137</b>
<b>D</b>	<b>Checklist operation.....</b>	<b>138</b>
<b>E</b>	<b>Checklist modification and retrofitting.....</b>	<b>139</b>
<b>F</b>	<b>Checklist decommissioning.....</b>	<b>140</b>

## A Checklist planning

### Checklist

Run. No.	Requirement	fulfilled		Notes
		yes	no	
<b>1</b>	<b>Planning</b>			
1.1	Was a risk evaluation established and were the required SIL and performance level according to DIN EN ISO 13849-1 or IEC 62061 determined?			
1.2	Are exclusively power supplies used according to PELV specification?			
1.3	Does the wiring take place after valid standards and guidelines?			
1.4	Is the power supply for the local I/O modules and field bus components correctly dimensioned?			
1.5	Do all the safety-related system components fulfill the requirements of the determined SIL (IEC 61508), performance level (DIN EN ISO 13849-1) and safety category (DIN EN 954-1)?			
1.6	Does the wiring of the safety components correspond to the requirements of the safety classification specified before?			
1.7	Do the components fulfill the environmental conditions of the application?			
1.8	Does the system fulfill the necessary degree of protection?			
1.9	Is degree of pollution 2 kept?			
1.10	Was the maximally permissible response time of the safety functions determined by a hazard analysis?			
1.11	Is the maximally permissible response time reached? Was the proof established by means of a calculation?			
1.12	Is the system protected against mechanical overloading?			
1.13	Is the system protected against aggressive media?			
1.14	Are the specified electrical values of the output terminals kept?			
1.15	Are all the electromechanical sensors supplied with clock pulses for the recognition of short-circuits?			
1.16	Was a list created, which contains all the parameters of the devices and its settings?			

Date:.....Name: .....Sign: .....

## B Checklist installation

### Checklist

Run. No.	Requirement	fulfilled		Notes
		yes	no	
<b>2</b>	<b>Installation</b>			
2.1	Is it guaranteed that the safety switch devices are not short-circuited due to a wiring fault?			
2.2	Is it guaranteed that the safety switch devices are not short-circuited due to a wiring fault?			
3.3	Was the wiring checked by means of the installation plan?			
2.4	Are all the plugs labelled according to their allocation?			
2.5	Are the connecting terminals with screws applied with the specified breakaway torque?			
2.6	Is guaranteed that the isolation of the lines does not lead to a faulty contact?			
2.7	Was the reliability of all the clamp connections controlled by a mechanical tensile load?			
2.8	Was a visual inspection of the installed components accomplished?			
2.9	Were necessary installation distances kept to other components?			
2.10	Do the components fulfill the environmental conditions of the application?			
2.11	Does the system fulfill the necessary degree of protection?			
2.12	Is degree of pollution 2 kept?			
2.13	Is the system protected against aggressive media?			

Date:.....Name: .....Sign: .....



## C Checklist commissioning, parameterization and validation

### Checklist

Run. No.	Requirement	fulfilled		Notes
		yes	no	
<b>3</b>	<b>Commissioning</b>			
3.1	Is guaranteed that all safe communication participants of a system have a clear safe device address (F-address)?  This is valid also for participants, which belong to different safety controllers, if the controllers are connected by gateways (e.g. Ethernet).			
3.2	Is the station number of the safety PLC correctly adjusted?			
3.3	Were the device parameters of the System SLIO safety modules validated?			
3.4	Was the safety cycle time determined and adjusted in the safety PLC?			
3.5	Was the maximum response time with the adjusted cycle time proofed by calculation?			
3.6	Were the project data copied on a memory card?			
3.7	Was a complete functional test accomplished and documented?			
3.8	Was the service personnel instructed into the handling of the control system?			
Date:.....Name: .....Sign: .....				

## D Checklist operation

### Checklist

Run. No.	Requirement	fulfilled		Notes
		yes	no	
<b>4</b>	<b>Operation</b>			
4.1	Is it guaranteed that no changes are made to the system configuration during operation of the safety PLC?			
4.2	Is it guaranteed that before expanding the system, removing individual system components and making changes to the wiring, the control system is set to a safe state dependent on the application by competent personnel?			
4.3	Are the ambient conditions specified in the technical data observed? ↪ Chap. 2.6 'SDI 4xDC 24V - Technical data' page 42 ↪ Chap. 2.10 'SDO 4xDC 24V 0.5A - Technical data' page 57			
4.4	Is it guaranteed that commissioning only takes place after acclimatisation of the System SLIO safety modules?			

Date: ..... Name: ..... Signature: .....

## E Checklist modification and retrofitting

### Checklist

Run. No.	Requirement	fulfilled		Notes
		yes	no	
<b>5</b>	<b>Modification and retrofitting</b>			
5.1	Is the modification/retrofitting compatible? Are the requirements of the checklists of planning, installation, commissioning and validation further fulfilled?			
5.2	Are the calculated reaction times further kept after modification/retrofitting? Proof necessary!			
5.3	Were the project data copied on a memory card?			
5.4	Was a complete functional test accomplished and documented?			
Date:.....Name: .....Sign: .....				

## F Checklist decommissioning

### Checklist

Run. No.	Requirement	fulfilled		Notes
		yes	no	
<b>6</b>	<b>Decommissioning</b>			
6.1	Is it guaranteed that the decommissioning is done by authorized and qualified personnel?			
6.2	Has the power supply been switched off at the device to be decommissioned?			
6.3	Has the wiring been removed from the device to be decommissioned?			
	Has the disassembly been carried out according to the disassembly description?  🔗 <i>Chap. 3.6 'Demounting and module exchange' page 84</i>			
6.4	Is it guaranteed that the defective System SLIO safety module decommissioned is sent to Yaskawa for disposal in its original packaging?			

Date: ..... Name: ..... Signature: .....