

VIPA System SLIO

SM-DIO | | Manual

HB300 | SM-DIO | | GB | 15-44

Digital signal modules - SM 02x

VIPA GmbH
Ohmstr. 4
91074 Herzogenaurach
Telephone: 09132-744-0
Fax: 09132-744-1864
Email: info@vipa.com
Internet: www.vipa.com

Table of contents

1	General	5
1.1	Copyright © VIPA GmbH	5
1.2	About this manual.....	6
1.3	Safety information.....	7
2	Basics and Assembly	9
2.1	Safety information for users.....	9
2.2	System conception.....	10
2.3	Dimensions.....	14
2.4	Installation.....	16
2.5	Demounting and module exchange.....	20
2.6	Wiring.....	24
2.7	Trouble shooting - LEDs.....	28
2.8	Installation guidelines.....	28
2.9	General data.....	31
3	Digital Input	33
3.1	021-1BB00 - DI 2xDC 24V.....	33
3.1.1	Technical data.....	35
3.2	021-1BB10 - DI 2xDC 24V 2µs...4ms.....	37
3.2.1	Technical data.....	39
3.2.2	Parameter data.....	41
3.2.3	Diagnostics and interrupt.....	42
3.3	021-1BB50 - DI 2xDC 24V NPN.....	45
3.3.1	Technical data.....	48
3.4	021-1BB70 - DI 2xDC 24V ETS.....	50
3.4.1	Technical data.....	54
3.4.2	Parameter data.....	56
3.4.3	Diagnostic data.....	60
3.5	021-1BD00 - DI 4xDC 24V.....	61
3.5.1	Technical data.....	64
3.6	021-1BD10 - DI 4xDC 24V 2µs...4ms.....	66
3.6.1	Technical data.....	68
3.6.2	Parameter data.....	70
3.6.3	Diagnostics and interrupt.....	71
3.7	021-1BD40 - DI 4xDC 24V 3 wire.....	75
3.7.1	Technical data.....	77
3.8	021-1BD50 - DI 4xDC 24V NPN.....	79
3.8.1	Technical data.....	81
3.9	021-1BD70 - DI 4xDC 24V ETS.....	83
3.9.1	Technical data.....	87
3.9.2	Parameter data.....	89
3.9.3	Diagnostic data.....	93
3.10	021-1BF00 - DI 8xDC 24V.....	94
3.10.1	Technical data.....	97
3.11	021-1BF01 - DI 8xDC 24V 0.5ms.....	99
3.11.1	Technical data.....	101
3.12	021-1BF50 - DI 8xDC 24V NPN.....	103
3.12.1	Technical data.....	105

3.13	021-1DF00 - DI 8xDC 24V Diagnosis.....	107
3.13.1	Technical data.....	110
3.13.2	Parameter data.....	112
3.13.3	Diagnostic data.....	113
4	Digital Output.....	116
4.1	022-1BB00 - DO 2xDC 24V 0.5A.....	116
4.1.1	Technical data.....	118
4.2	022-1BB20 - DO 2xDC 24V 2A.....	120
4.2.1	Technical data.....	122
4.3	022-1BB50 - DO 2xDC 24V 0.5A NPN.....	124
4.3.1	Technical data.....	127
4.4	022-1BB70 - DO 2xDC 24V 0.5A ETS.....	129
4.4.1	Technical data.....	135
4.4.2	Parameter data.....	138
4.4.3	Diagnostic data.....	143
4.5	022-1BB90 - DO 2xDC 24V 0.5A PWM.....	145
4.5.1	Technical data.....	149
4.5.2	Parameter data.....	151
4.5.3	Diagnostic data.....	152
4.6	022-1BD00 - DO 4xDC 24V 0.5A.....	154
4.6.1	Technical data.....	156
4.7	022-1BD20 - DO 4xDC 24V 2A.....	158
4.7.1	Technical data.....	160
4.8	022-1BD50 - DO 4xDC 24V 0.5A NPN.....	162
4.8.1	Technical data.....	165
4.9	022-1BD70 - DO 4xDC 24V 0.5A ETS.....	167
4.9.1	Technical data.....	173
4.9.2	Parameter data.....	176
4.9.3	Diagnostic data.....	181
4.10	022-1BF00 - DO 8xDC 24V 0.5A.....	183
4.10.1	Technical data.....	185
4.11	022-1BF50 - DO 8xDC 24V 0.5A NPN.....	187
4.11.1	Technical data.....	190
4.12	022-1DF00 - DO 8xDC 24V 0.5A Diagnostic.....	192
4.12.1	Technical data.....	195
4.12.2	Parameter data.....	197
4.12.3	Diagnostic data.....	198
4.13	022-1HB10 - DO 2xRelay.....	200
4.13.1	Technical data.....	203

1 General

1.1 Copyright © VIPA GmbH

All Rights Reserved

This document contains proprietary information of VIPA and is not to be disclosed or used except in accordance with applicable agreements.

This material is protected by the copyright laws. It may not be reproduced, distributed, or altered in any fashion by any entity (either internal or external to VIPA), except in accordance with applicable agreements, contracts or licensing, without the express written consent of VIPA and the business management owner of the material.

For permission to reproduce or distribute, please contact: VIPA, Gesellschaft für Visualisierung und Prozessautomatisierung mbH Ohmstraße 4, D-91074 Herzogenaurach, Germany

Tel.: +49 9132 744 -0

Fax.: +49 9132 744-1864

E-Mail: info@vipa.de

<http://www.vipa.com>



Every effort has been made to ensure that the information contained in this document was complete and accurate at the time of publishing. Nevertheless, the authors retain the right to modify the information.

This customer document describes all the hardware units and functions known at the present time. Descriptions may be included for units which are not present at the customer site. The exact scope of delivery is described in the respective purchase contract.

CE Conformity Declaration

Hereby, VIPA GmbH declares that the products and systems are in compliance with the essential requirements and other relevant provisions. Conformity is indicated by the CE marking affixed to the product.

Conformity Information

For more information regarding CE marking and Declaration of Conformity (DoC), please contact your local VIPA customer service organization.

Trademarks

VIPA, SLIO, System 100V, System 200V, System 300V, System 300S, System 400V, System 500S and Commander Compact are registered trademarks of VIPA Gesellschaft für Visualisierung und Prozessautomatisierung mbH.

SPEED7 is a registered trademark of profichip GmbH.

SIMATIC, STEP, SINEC, TIA Portal, S7-300 and S7-400 are registered trademarks of Siemens AG.

Microsoft and Windows are registered trademarks of Microsoft Inc., USA.

Portable Document Format (PDF) and Postscript are registered trademarks of Adobe Systems, Inc.

All other trademarks, logos and service or product marks specified herein are owned by their respective companies.

Information product support

Contact your local VIPA Customer Service Organization representative if you wish to report errors or questions regarding the contents of this document. If you are unable to locate a customer service centre, contact VIPA as follows:

VIPA GmbH, Ohmstraße 4, 91074 Herzogenaurach, Germany

Telefax: +49 9132 744-1204

E-Mail: documentation@vipa.de

Technical support

Contact your local VIPA Customer Service Organization representative if you encounter problems with the product or have questions regarding the product. If you are unable to locate a customer service centre, contact VIPA as follows:

VIPA GmbH, Ohmstraße 4, 91074 Herzogenaurach, Germany

Tel.: +49 9132 744-1150 (Hotline)

E-Mail: support@vipa.de

1.2 About this manual

Target audience

The manual is targeted at users who have a background in automation technology.

Structure of the manual

The manual consists of chapters. Every chapter provides a self-contained description of a specific topic.

Guide to the document

The following guides are available in the manual:

- An overall table of contents at the beginning of the manual
- References with page numbers

Availability

The manual is available in:

- printed form, on paper
- in electronic form as PDF-file (Adobe Acrobat Reader)

Icons Headings

Important passages in the text are highlighted by following icons and headings:



DANGER!

Immediate or likely danger. Personal injury is possible.



CAUTION!

Damages to property is likely if these warnings are not heeded.



Supplementary information and useful tips.

1.3 Safety information

Applications conforming with specifications

The system is constructed and produced for:

- communication and process control
- industrial applications
- operation within the environmental conditions specified in the technical data
- installation into a cubicle



DANGER!

This device is not certified for applications in
 – in explosive environments (EX-zone)

Documentation

The manual must be available to all personnel in the

- project design department
- installation department
- commissioning
- operation



CAUTION!

The following conditions must be met before using or commissioning the components described in this manual:

- Hardware modifications to the process control system should only be carried out when the system has been disconnected from power!
- Installation and hardware modifications only by properly trained personnel.
- The national rules and regulations of the respective country must be satisfied (installation, safety, EMC ...)

Safety information

Disposal

National rules and regulations apply to the disposal of the unit!

2 Basics and Assembly

2.1 Safety information for users

Handling of electrostatic sensitive modules

VIPA modules make use of highly integrated components in MOS-Technology. These components are extremely sensitive to over-voltages that can occur during electrostatic discharges. The following symbol is attached to modules that can be destroyed by electrostatic discharges.



The Symbol is located on the module, the module rack or on packing material and it indicates the presence of electrostatic sensitive equipment. It is possible that electrostatic sensitive equipment is destroyed by energies and voltages that are far less than the human threshold of perception. These voltages can occur where persons do not discharge themselves before handling electrostatic sensitive modules and they can damage components thereby, causing the module to become inoperable or unusable. Modules that have been damaged by electrostatic discharges can fail after a temperature change, mechanical shock or changes in the electrical load. Only the consequent implementation of protection devices and meticulous attention to the applicable rules and regulations for handling the respective equipment can prevent failures of electrostatic sensitive modules.

Shipping of modules

Modules must be shipped in the original packing material.

Measurements and alterations on electrostatic sensitive modules

When you are conducting measurements on electrostatic sensitive modules you should take the following precautions:

- Floating instruments must be discharged before use.
- Instruments must be grounded.

Modifying electrostatic sensitive modules you should only use soldering irons with grounded tips.



CAUTION!

Personnel and instruments should be grounded when working on electrostatic sensitive modules.

2.2 System conception

Overview

System SLIO is a modular automation system for assembly on a 35mm mounting rail. By means of the peripheral modules with 2, 4 or 8 channels this system may properly be adapted matching to your automation tasks. The wiring complexity is low, because the supply of the DC 24V power section is integrated to the backplane bus and defective modules may be replaced with standing wiring. By deployment of the power modules in contrasting colours within the system, further isolated areas may be defined for the DC 24V power section supply, respectively the electronic power supply may be extended with 2A.

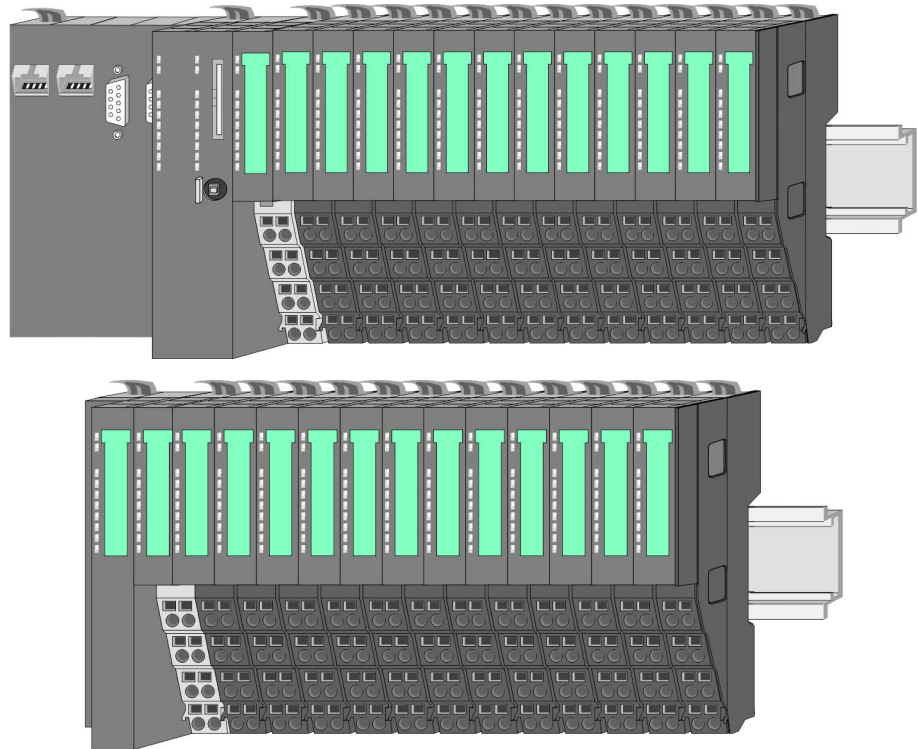

Components

- CPU (head module)
- Bus coupler (head module)
- Periphery modules
- Power modules
- Accessories



CAUTION!

Only modules of VIPA may be combined. A mixed operation with third-party modules is not allowed!

CPU



With a CPU, CPU electronic and power module are integrated to one casing. As head module via the integrated power module for power supply the CPU electronic is supplied as well as the electronic of the connected periphery modules. The DC 24 power section supply for the linked periphery modules is established via a further connection at the power module. By installing of up to 64 periphery modules at the CPU, these are electrically connected, this means these are assigned to the backplane bus, the electronic modules are power supplied and each periphery module is connected to the DC 24V power section supply.



CAUTION!

CPU part and power module of a CPU may not be separated! Here you may only exchange the electronic module!

Bus coupler

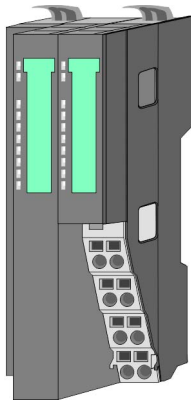

With a bus coupler bus interface and power module are integrated to one casing. With the bus interface you get access to a subordinated bus system. As head module via the integrated power module for power supply the bus interface is supplied as well as the electronic of the connected periphery modules. The DC 24 power section supply for the linked periphery modules is established via a further connection at the power module. By installing of up to 64 periphery modules at the bus coupler, these are electrically connected, this means these are assigned to the backplane bus, the electronic modules are power supplied and each periphery module is connected to the DC 24V power section supply.



CAUTION!

Bus interface and power module of the bus coupler may not be separated! Here you may only exchange the electronic module!

Periphery modules

Each periphery module consists of a *terminal* and an *electronic module*.

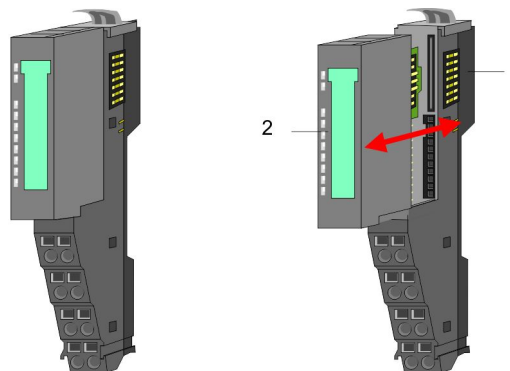

- 1 Terminal module
- 2 Electronic module

Terminal module

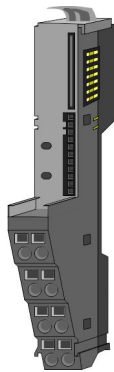

The *terminal module* serves to carry the electronic module, contains the backplane bus with power supply for the electronic, the DC 24V power section supply and the staircase-shaped terminal for wiring. Additionally the terminal module has a locking system for fixing at a mounting rail. By means of this locking system your SLIO system may be assembled outside of your switchgear cabinet to be later mounted there as whole system.

Electronic module

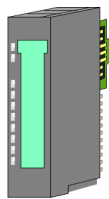

The functionality of a SLIO periphery module is defined by the *electronic module*, which is mounted to the terminal module by a safe sliding mechanism. With an error the defective module may be exchanged for a functional module with standing installation.

At the front side there are LEDs for status indication. For simple wiring each module shows a corresponding connection diagram at the front and at the side.

Power module

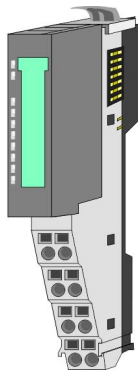

In the System SLIO the power supply is established by power modules. These are either integrated to the head module or may be installed between the periphery modules. Depending on the power module isolated areas of the DC 24V power section supply may be defined respectively the electronic power supply may be extended with 2A. For better recognition the colour of the power modules are contrasting to the periphery modules.

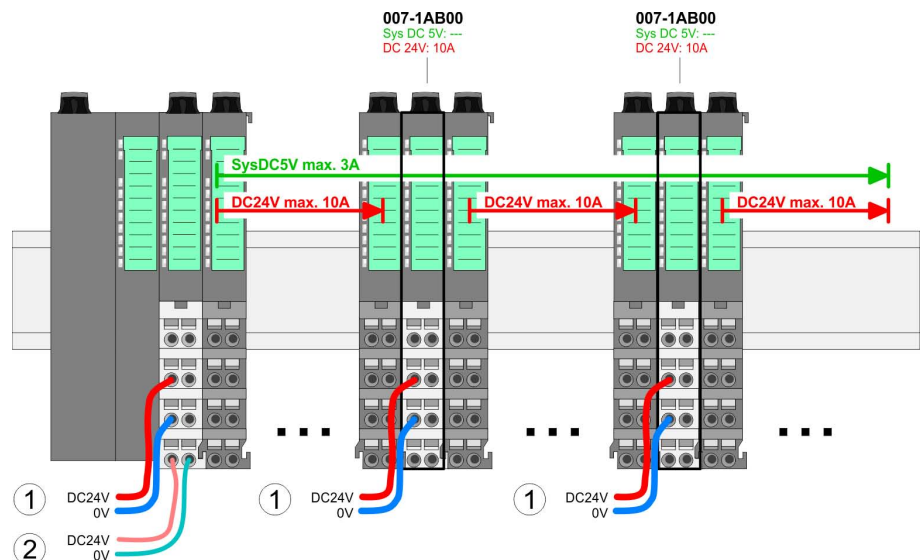

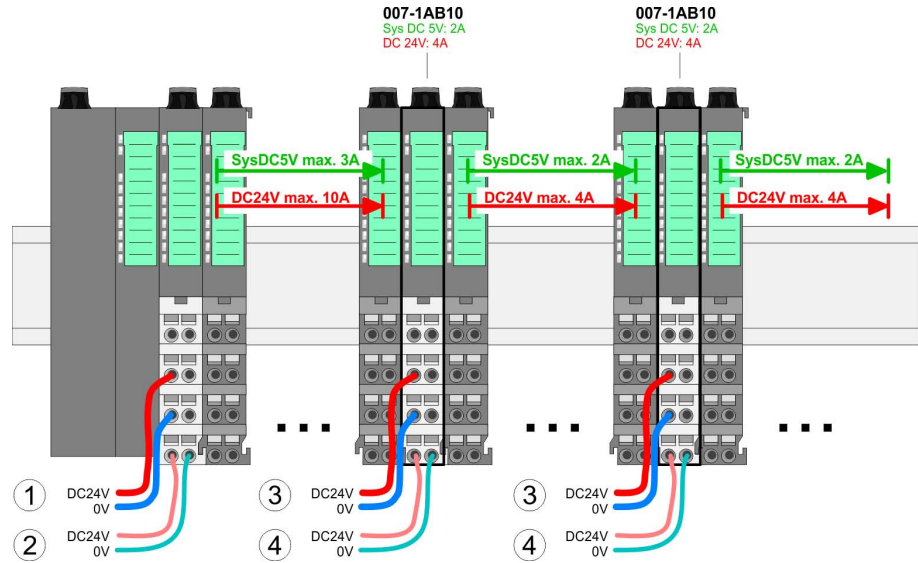

- (1) DC 24V for power section supply I/O area (max. 10A)
- (2) DC 24V for electronic power supply bus coupler and I/O area
- (3) DC 24V for power section supply I/O area (max. 4A)
- (4) DC 24V for electronic power supply I/O area

Accessories

Shield bus carrier



The shield bus carrier (order no. 000-0AB00) serves to carry the shield bus (10mm x 3mm) to connect cable shields. Shield bus carriers, shield bus and shield fixings are not in the scope of delivery. They are only available as accessories. The shield bus carrier is mounted underneath the terminal of the terminal module. With a flat mounting rail for adaption to a flat mounting rail you may remove the spacer of the shield bus carrier.

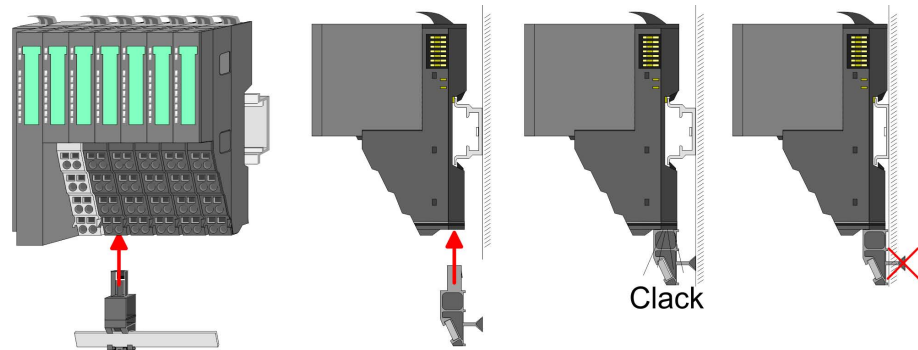

Bus cover

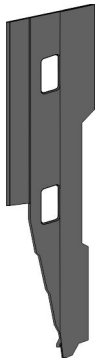

With each bus coupler, to protect the backplane bus connectors, there is a mounted bus cover in the scope of delivery. You have to remove the bus cover of the bus coupler before mounting a SLIO module. For the protection of the backplane bus connector you always have to mount the bus cover at the last module of your system again.

The bus cover has the order no. 000-0AA00.

Coding pins



There is the possibility to fix the assignment of electronic and terminal module. Here coding pins (order number 000-0AC00) from VIPA can be used. The coding pin consists of a coding jack and a coding plug. By combining electronic and terminal module with coding pin, the coding jack remains in the electronic module and the coding plug in the terminal module. This ensures that after replacing the electronics module just another electronic module can be plugged with the same encoding.

2.3 Dimensions

Dimensions CPU

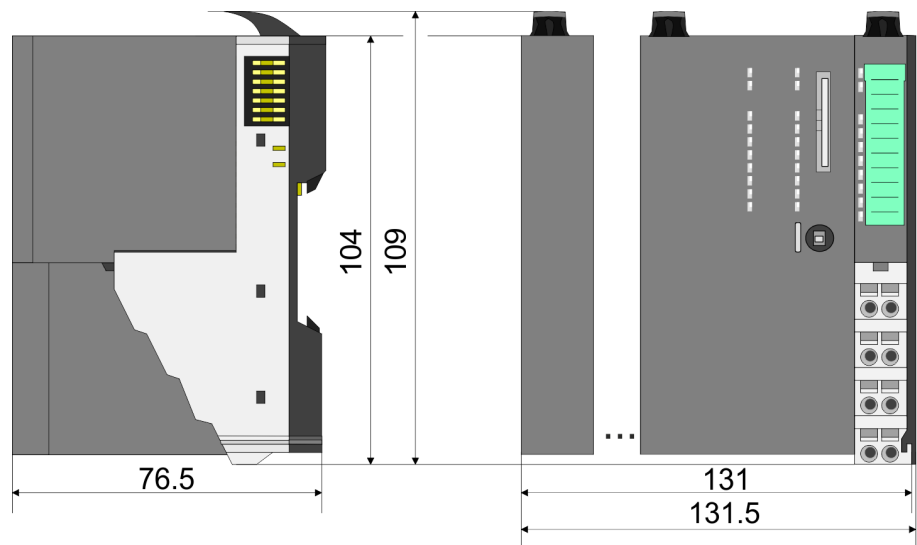

Dimensions bus coupler

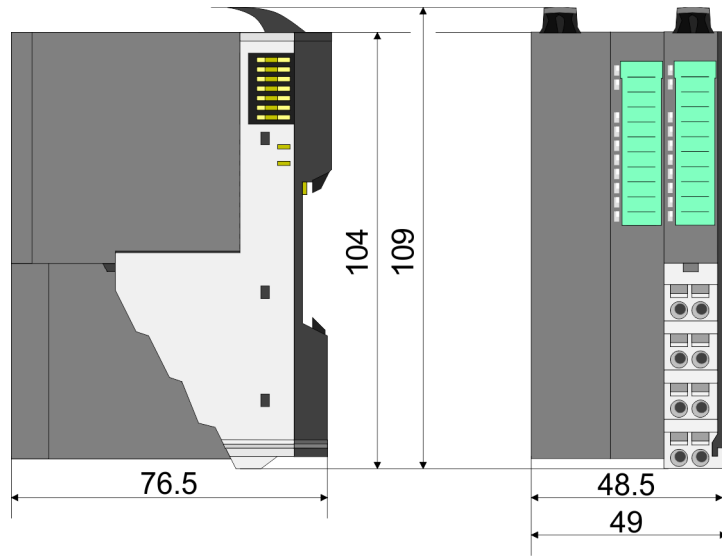

Dimensions periphery module

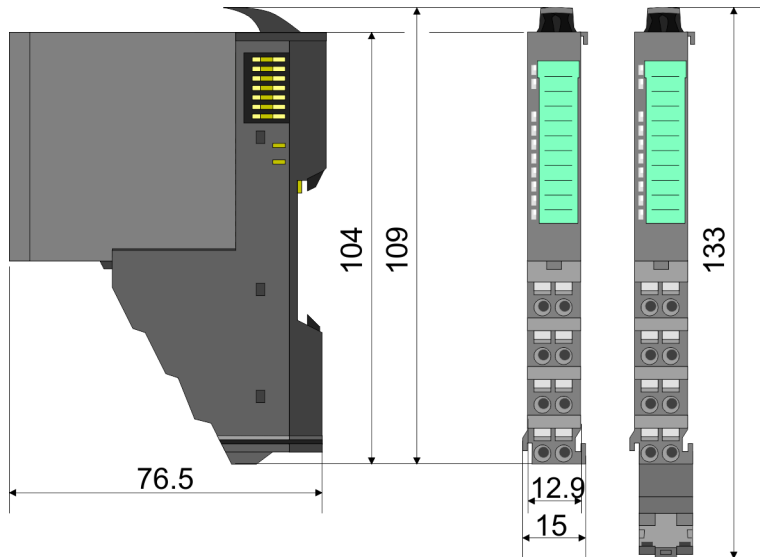

Dimensions electronic module

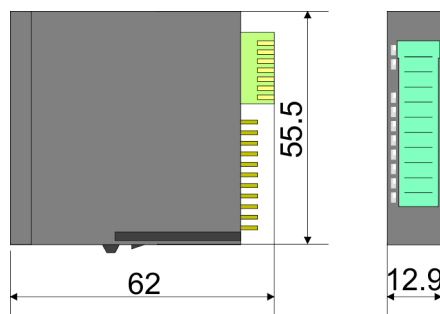

Dimensions in mm

2.4 Installation

Functional principle

There is a locking lever at the top side of the terminal module. For mounting and demounting this locking lever is to be turned upwards until this engages audible. Now the module may be pulled forward. For mounting plug the module to the module installed before and push the module to the mounting rail guided by the strips at the upper and lower side of the module. The module is fixed to the mounting rail by pushing downward the locking lever. The modules may either separately be mounted to the mounting rail or as block. Here is to be considered that each locking lever is opened.

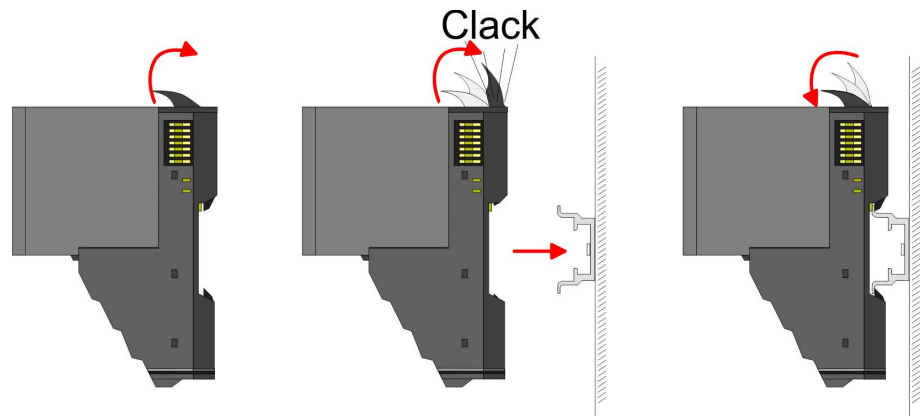

For the exchange of a electronic module, the electronic module may be pulled forward after pressing the unlocking lever at the lower side of the module. For installation plug the electronic module guided by the strips at the lower side until this engages audible to the terminal module.

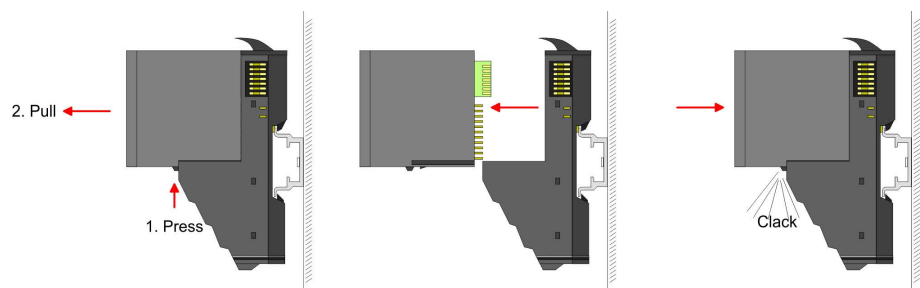

Coding



There is the possibility to fix the assignment of electronic and terminal module. Here coding pins (order number 000-0AC00) from VIPA can be used. The coding pin consists of a coding jack and a coding plug. By combining electronic and terminal module with coding pin, the coding jack remains in the electronic module and the coding plug in the terminal module. This ensures that after replacing the electronics module just another electronic module can be plugged with the same encoding.

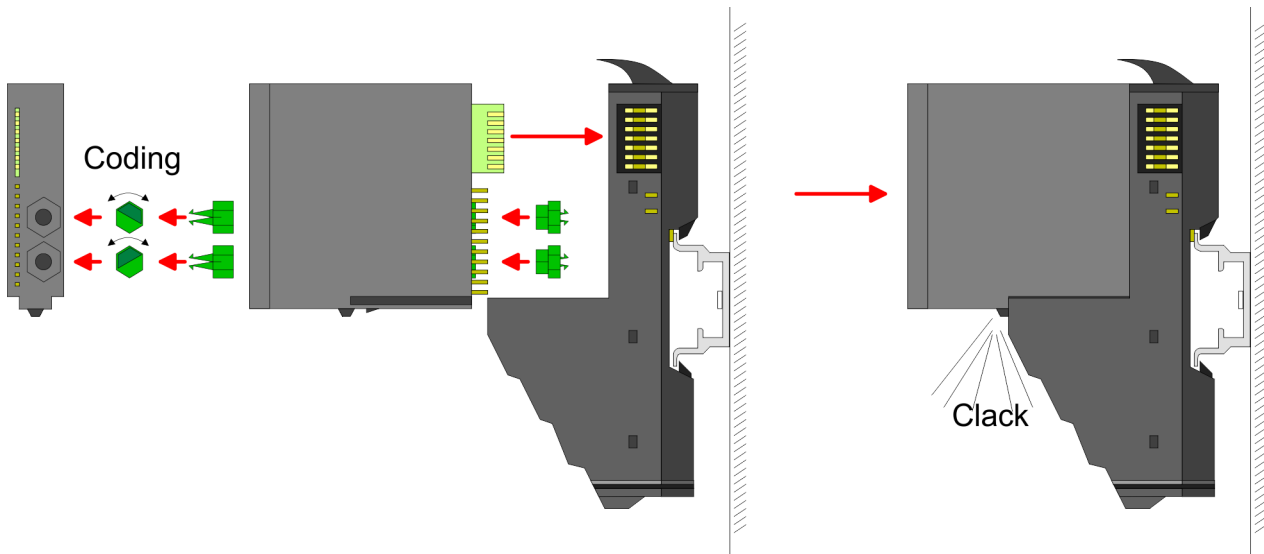

Each electronic module has on its back 2 coding sockets for coding jacks. Due to the characteristics, with the coding jack 6 different positions can be plugged, each. Thus there are 36 possible combinations for coding with the use of both coding sockets.

1. ► Plug, according to your coding, 2 coding jacks in the coding sockets of your electronic module until they lock.
2. ► Now plug the according coding plugs into the coding jacks.
3. ► To fix the coding put both the electronic and terminal module together until they lock.



CAUTION!

Please consider that when replacing an already coded electronic module, this is always be replaced by an electronic module with the same coding.

Even with an existing coding on the terminal module, you can plug an electronic module without coding. The user is responsible for the correct usage of the coding pins. VIPA assumes no liability for incorrectly attached electronic modules or for damages which arise due to incorrect coding!

Mounting Proceeding

The modules were directly be mounted to the mounting rail and so connected to the backplane bus and the power supply for the electronic and power section. Up to 64 modules may be mounted. Please consider here that the sum current of the electronic power supply does not exceed the maximum value of 3A. By means of the power module 007-1AB10 the current of the electronic power supply may be expanded with 2A. ↪ *Chapter 2.6 'Wiring' on page 24*

Mounting rail

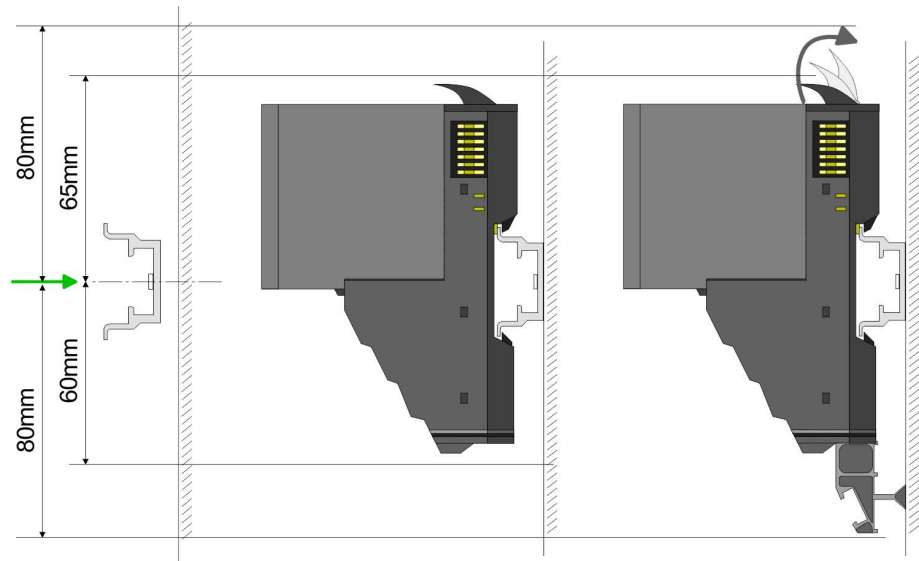

- ➔ Mount the mounting rail! Please consider that a clearance from the middle of the mounting rail of at least 80mm above and 60mm below, respectively 80mm by deployment of shield bus carriers, exist.

Mounting Head module (e.g. bus coupler)

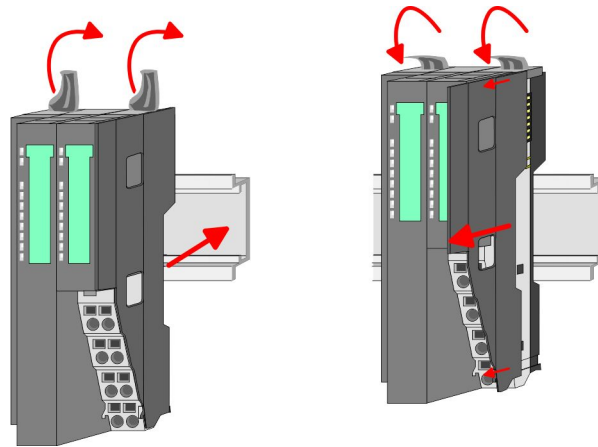

1. ➔ Start at the left side with the head module (e.g. bus coupler). For this turn both locking lever upwards, put the head module to the mounting rail and turn both locking lever downward.
2. ➔ Before mounting the periphery modules you have to remove the bus cover at the right side of the Head module by pulling it forward. Keep the cover for later mounting.

Mounting periphery modules

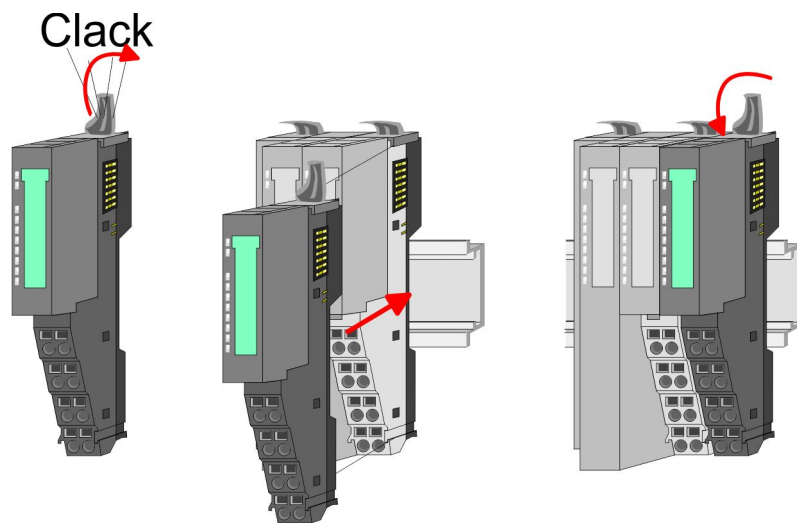

➔ Mount the periphery modules you want.

Mounting the bus cover

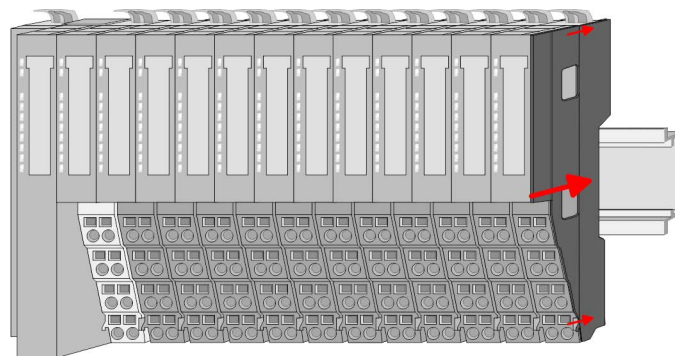

➔ After mounting the whole system, to protect the backplane bus connectors at the last module you have to mount the bus cover, now.

Mounting the bus cover at a clamp module

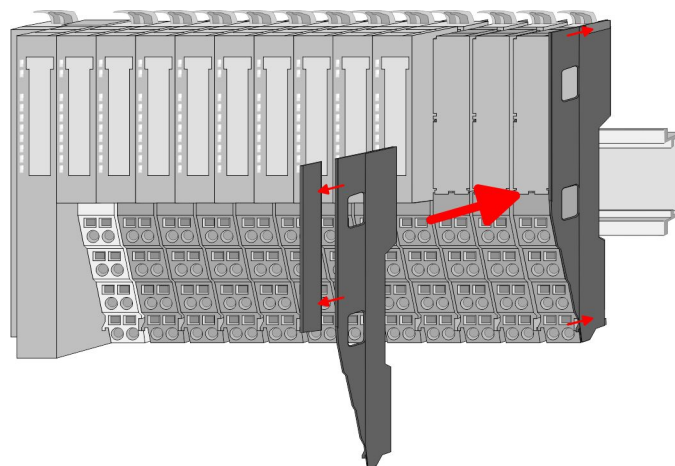

➔ If the last module is a clamp module, for adaptation the upper part of the bus cover is to be removed

Mounting shield bus carrier

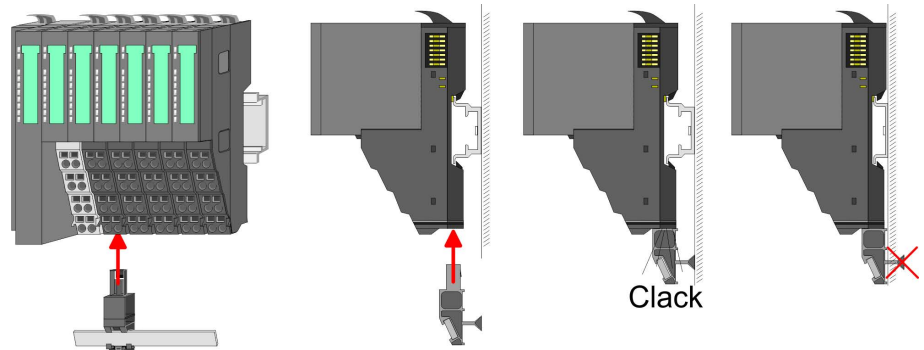

➔ The shield bus carrier (available as accessory) serves to carry the shield bus to connect cable shields. The shield bus carrier is mounted underneath the terminal of the terminal module. With a flat mounting rail for adaption to a flat mounting rail you may remove the spacer of the shield bus carrier.

2.5 Demounting and module exchange

Proceeding

With demounting and exchange of a module, head module (e.g. bus coupler) or a group of modules for mounting reasons you have always to remove the electronic module of the just mounted right module. After the mounting it may be plugged again.

Exchange of an electronic module

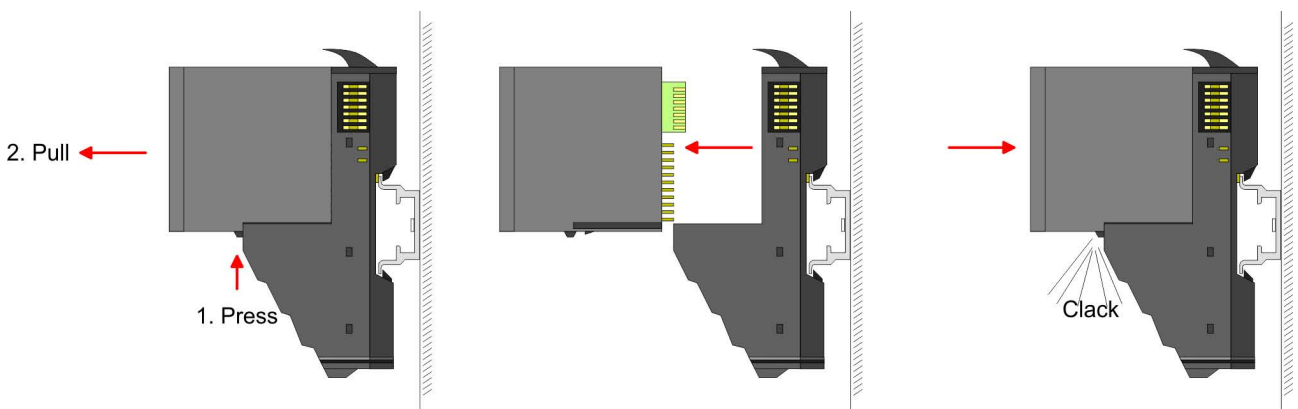

1. ➔ For the exchange of an electronic module, the electronic module may be pulled forward after pressing the unlocking lever at the lower side of the module.
2. ➔ For installation plug the electronic module guided by the strips at the lower side until this engages audible to the terminal module.

Exchange of a module

1. ▶ Remove if exists the wiring. ↪ Chapter 2.6 'Wiring' on page 24.

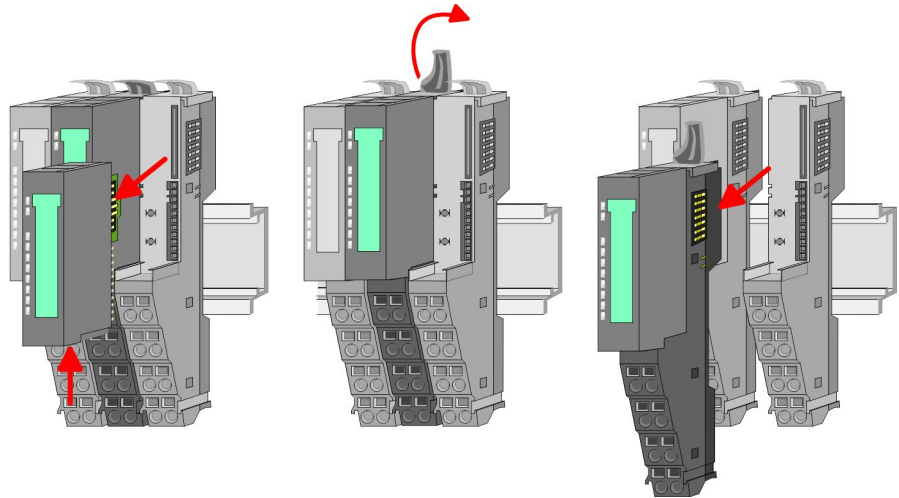

2. ▶ Press the unlocking lever at the lower side of the just mounted right module and pull it forward.
3. ▶ Turn the locking lever of the module to be exchanged upwards.
4. ▶ Pull the module forward.

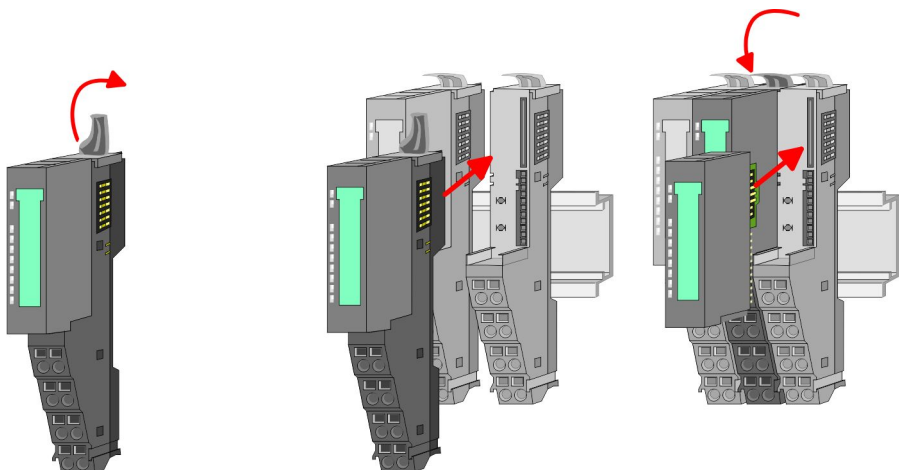

5. ▶ For mounting turn the locking lever of the module to be mounted upwards.
6. ▶ To mount the module put it to the gap between the both modules and push it, guided by the stripes at both sides, to the mounting rail.
7. ▶ Turn the locking lever downward again.
8. ▶ Plug again the electronic module, which you have removed before.

Exchange of a head module (e.g. bus coupler)



CAUTION!

Bus interface and power module of a head module may not be separated!

Here you may only exchange the electronic module!

1. ➤ Remove if exists the wiring of the head module. ↪ *Chapter 2.6 'Wiring' on page 24.*

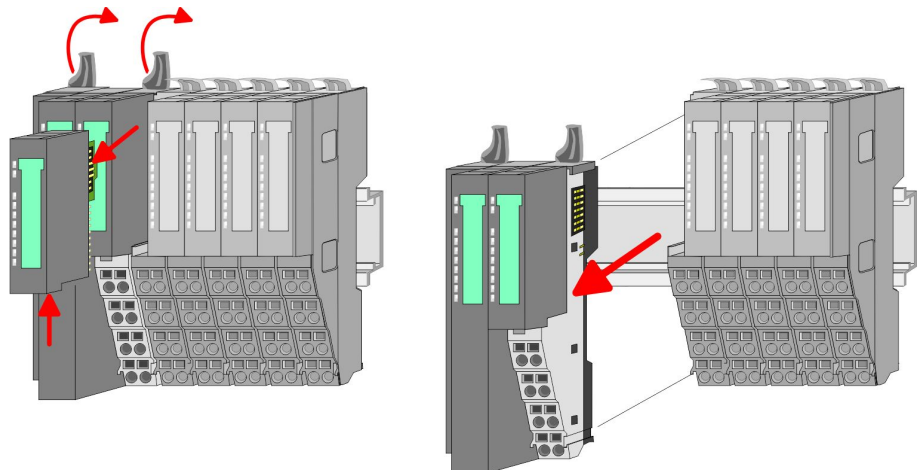

2. ➤ Press the unlocking lever at the lower side of the just mounted right module and pull it forward.
3. ➤ Turn all the locking lever of the head module to be exchanged upwards.
4. ➤ Pull the head module forward.

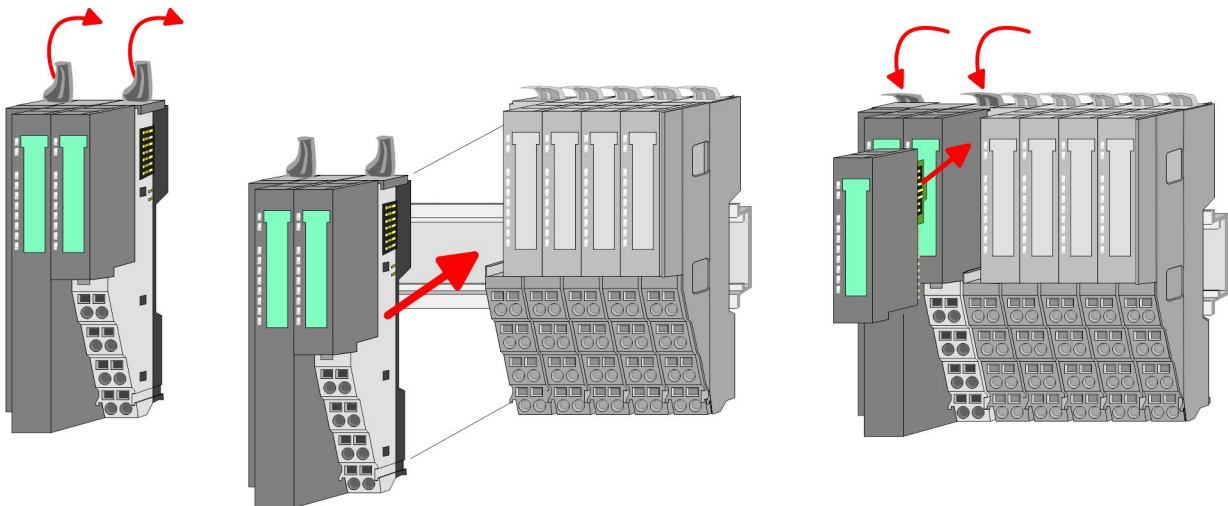

5. ➤ For mounting turn all the locking lever of the head module to be mounted upwards.
6. ➤ To mount the head module put it to the left module and push it, guided by the stripes, to the mounting rail.
7. ➤ Turn all the locking lever downward again.
8. ➤ Plug again the electronic module, which you have removed before.

Exchange of a module group

1. Remove if exists the wiring of the module group. ↪ *Chapter 2.6 'Wiring' on page 24.*

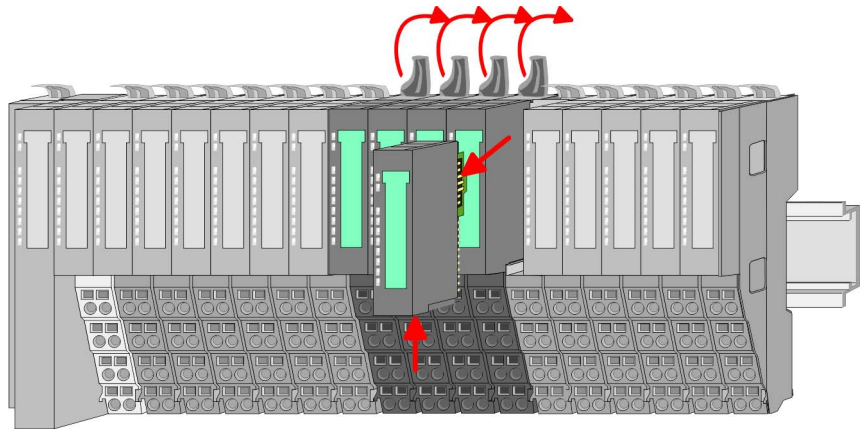

2. Press the unlocking lever at the lower side of the just mounted right module of the module group and pull it forward.

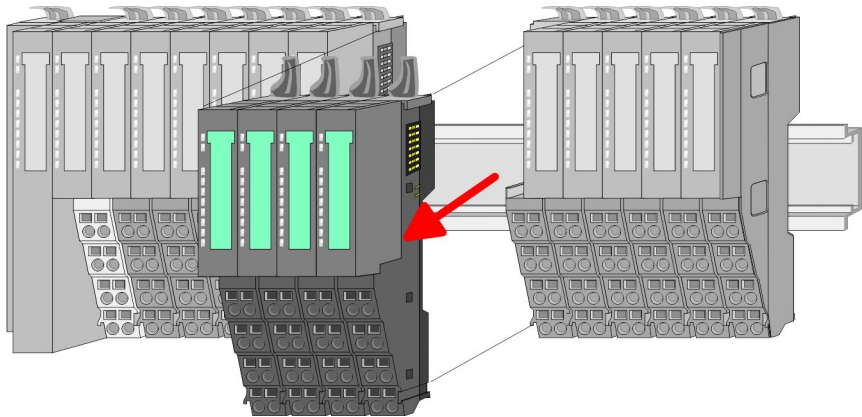

3. Turn all the locking lever of the module group to be exchanged upwards.

4. Pull the module group forward.

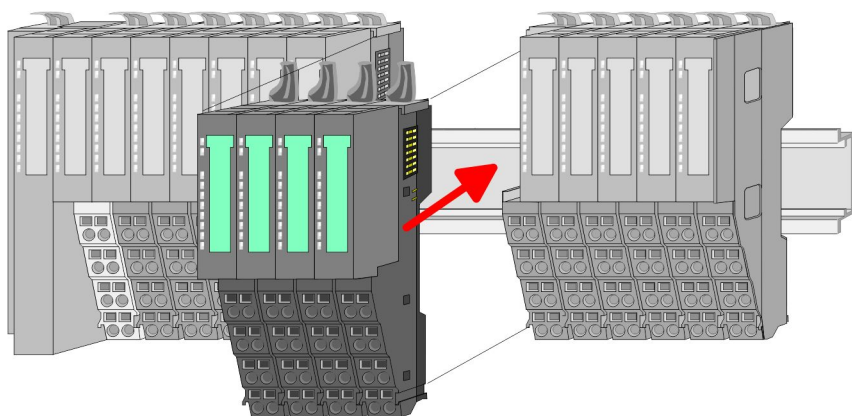
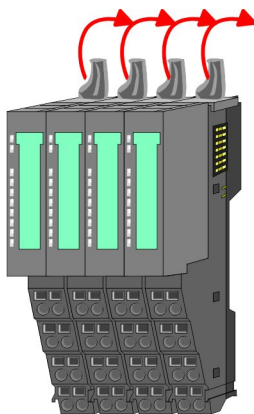

5. For mounting turn all the locking lever of the module group to be mounted upwards.

6. To mount the module group put it to the gap between the both modules and push it, guided by the stripes at both sides, to the mounting rail.

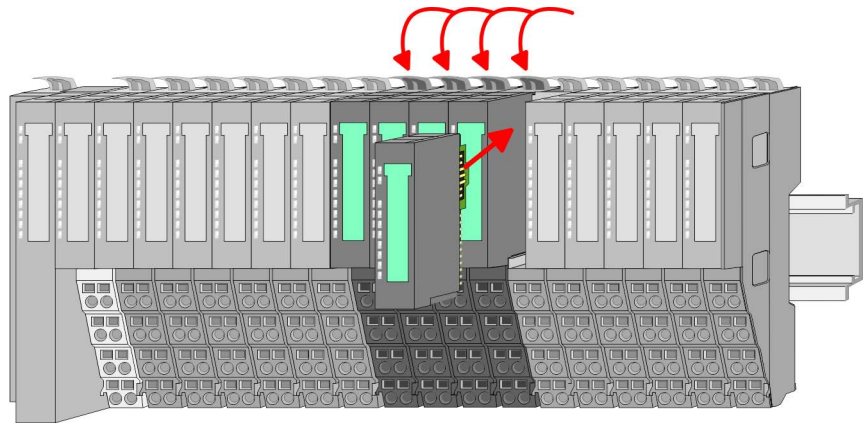

7. ➤ Turn all the locking lever downward again.
8. ➤ Plug again the electronic module, which you have removed before.

2.6 Wiring Connectors

Terminals with spring clamp technology are used for wiring.

The spring clamp technology allows quick and easy connection of your signal and supply lines.

In contrast to screw terminal connections this type of connection is vibration proof.

Data

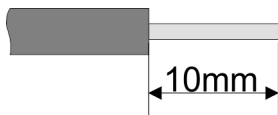

U_{max} : 240V AC / 30V DC

I_{max} : 10A

Cross section: 0.08 ... 1.5mm² (AWG 28 ... 16)

Stripping length: 10mm

Wiring procedure

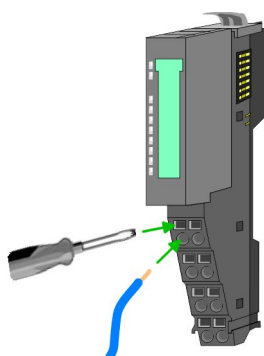
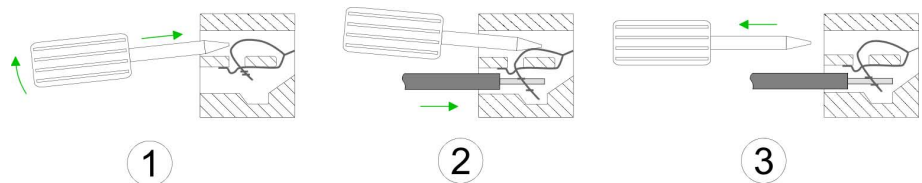

1. ➤ Insert a suited screwdriver at an angle into the square opening as shown. Press and hold the screwdriver in the opposite direction to open the contact spring.
2. ➤ Insert the stripped end of wire into the round opening. You can use wires with a cross section of 0.08mm² to 1.5mm².
3. ➤ By removing the screwdriver, the wire is securely fixed via the spring contact to the terminal.

Standard wiring

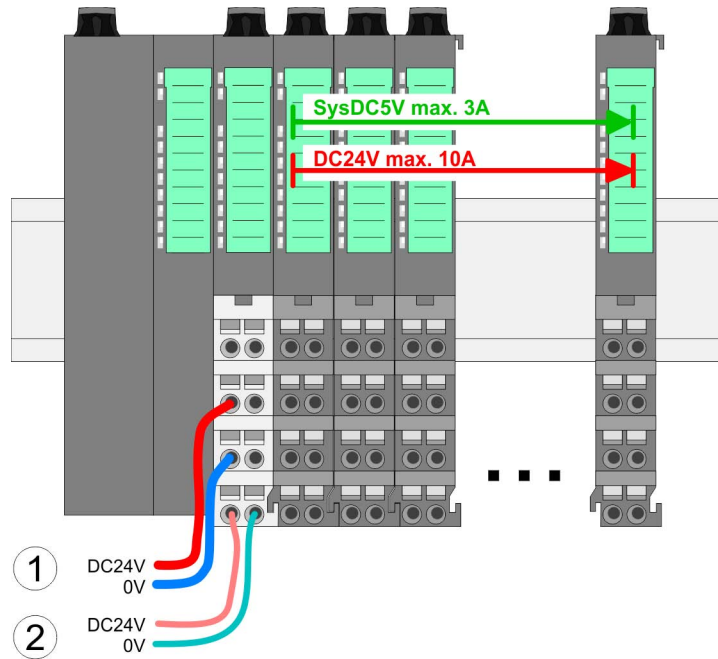

- (1) DC 24V for power section supply I/O area (max 10A)
- (2) DC 24V for electronic power supply bus coupler and I/O area

PM - Power module

For wires with a core cross-section of 0.08mm² up to 1.5mm².

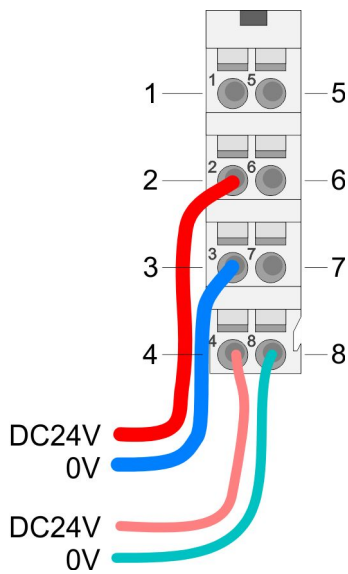

Pos.	Function	Type	Description
1	---	---	not connected
2	DC 24V	I	DC 24V for power section supply
3	0V	I	GND for power section supply
4	Sys DC 24V	I	DC 24V for electronic section supply
5	---	---	not connected
6	DC 24V	I	DC 24V for power section supply
7	0V	I	GND for power section supply
8	Sys 0V	I	GND for electronic section supply

I Input



CAUTION!

Since the power section supply is not internally protected, it is to be externally protected with a fuse, which corresponds to the maximum current. This means max. 10A is to be protected by a 10A fuse (fast) respectively by a line circuit breaker 10A characteristics Z!



The electronic power section supply is internally protected against higher voltage by fuse. The fuse is within the power module. If the fuse releases, its electronic module must be exchanged!

Fusing

- The power section supply is to be externally protected with a fuse, which corresponds to the maximum current. This means max. 10A is to be protected with a 10A fuse (fast) respectively by a line circuit breaker 10A characteristics Z!
- It is recommended to externally protect the electronic power supply for bus coupler and I/O area with a 2A fuse (fast) respectively by a line circuit breaker 2A characteristics Z.
- The electronic power supply for the I/O area of the power module 007-1AB10 should also be externally protected with a 1A fuse (fast) respectively by a line circuit breaker 1A characteristics Z.

State of the electronic power supply via LEDs

After PowerON of the System SLIO the LEDs RUN respectively MF get on so far as the sum current does not exceed 3A.

With a sum current greater than 3A the LEDs may not be activated.

Here the power module with the order number 007-1AB10 is to be placed between the peripheral modules.

Deployment of the power modules

If the 10A for the power section supply is no longer sufficient, you may use the power module from VIPA with the order number 007-1AB00. So you have also the possibility to define isolated groups.

The power module with the order number 007-1AB10 is to be used if the 3A for the electronic power supply at the backplane bus is no longer sufficient. Additionally you get an isolated group for the DC 24V power section supply with 4A.

By placing the power module 007-1AB10 at the following backplane bus modules may be placed with a sum current of max. 2A. Afterwards the power module 007-1AB10 is to be placed again. To secure the power supply, the power modules may be mixed used.

Power module 007-1AB00

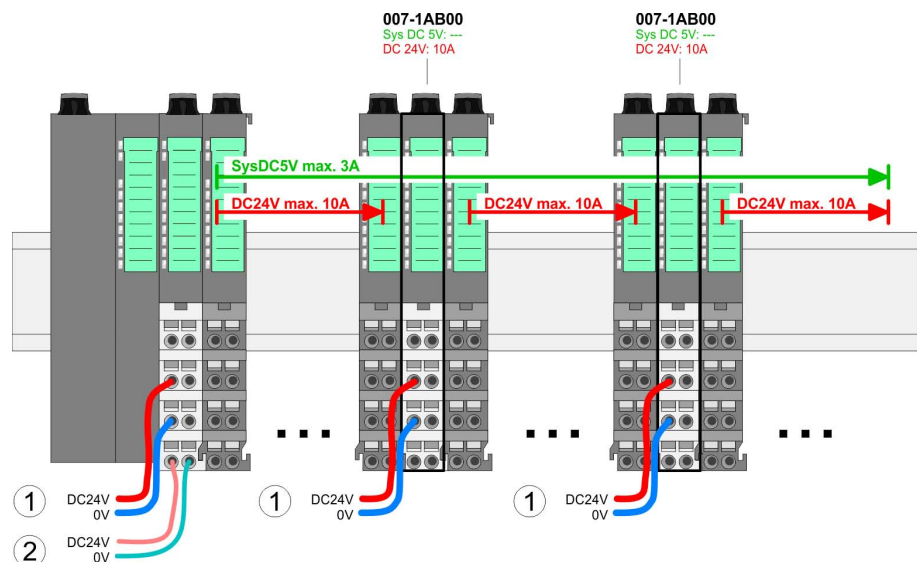

**Power module
007-1AB10**

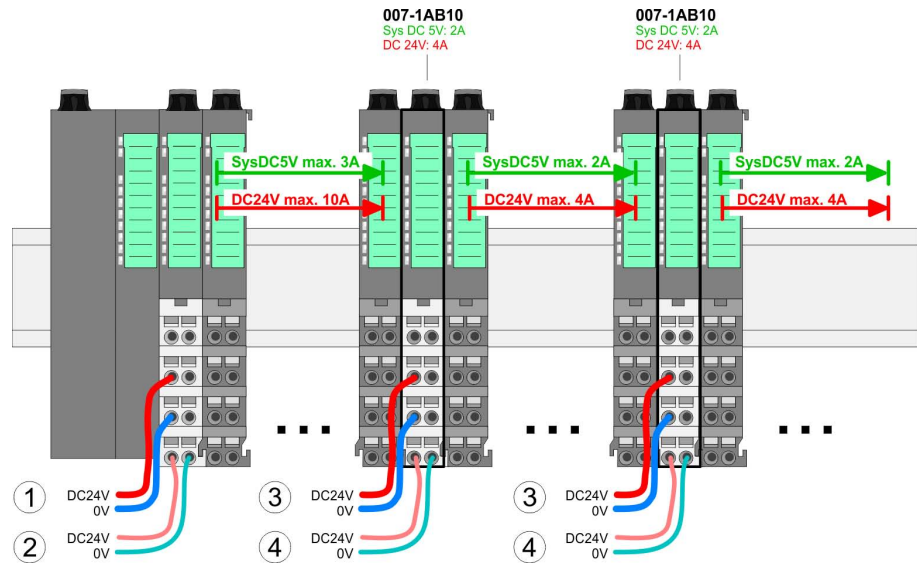

- (1) DC 24V for power section supply I/O area (max. 10A)
- (2) DC 24V for electronic power supply bus coupler and I/O area
- (3) DC 24V for power section supply I/O area (max. 4A)
- (4) DC 24V for electronic power supply I/O area

Shield attachment

To attach the shield the mounting of shield bus carriers are necessary.

The shield bus carrier (available as accessory) serves to carry the shield bus to connect cable shields.

The shield bus carrier is mounted underneath the terminal of the terminal module. With a flat mounting rail for adaption to a flat mounting rail you may remove the spacer of the shield bus carrier.

After mounting the shield bus carrier with the shield bus, the cables with the accordingly stripped cable screen may be attached and fixed by the shield clamp.

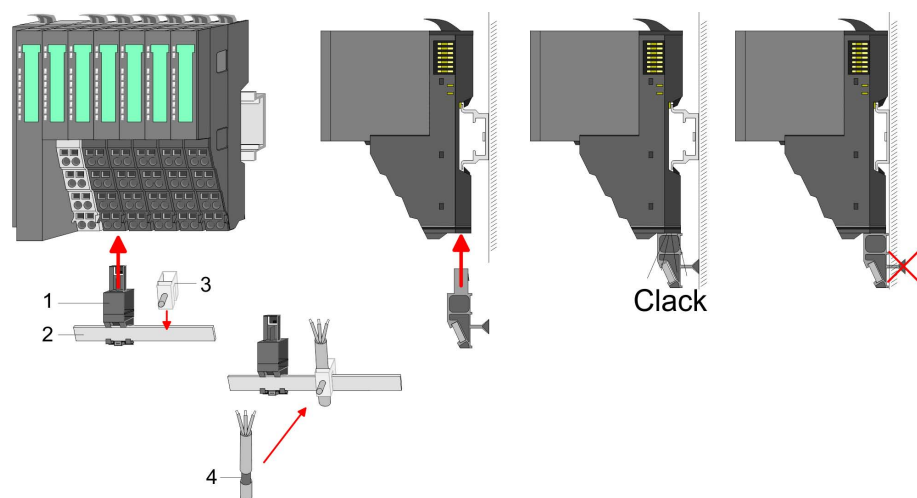

- 1 Shield bus carrier
- 2 Shield bus (10mm x 3mm)
- 3 Shield clamp
- 4 Cable shield

2.7 Trouble shooting - LEDs

General

Each module has the LEDs RUN and MF on its front side. Errors or incorrect modules may be located by means of these LEDs.

In the following illustrations flashing LEDs are marked by ☼.

Sum current of the electronic power supply exceeded

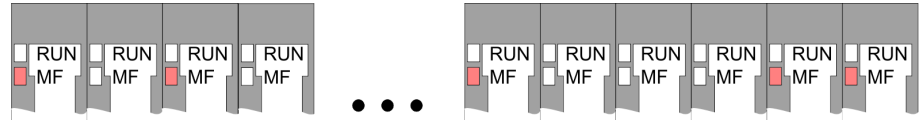

Behaviour: After PowerON the RUN LED of each module is off and the MF LED of each module is sporadically on.

Reason: The maximum current for the electronic power supply is exceeded.

Remedy: As soon as the sum current of the electronic power supply is exceeded, always place the power module 007-1AB10. ☞ Chapter 2.6 'Wiring' on page 24

Error in configuration

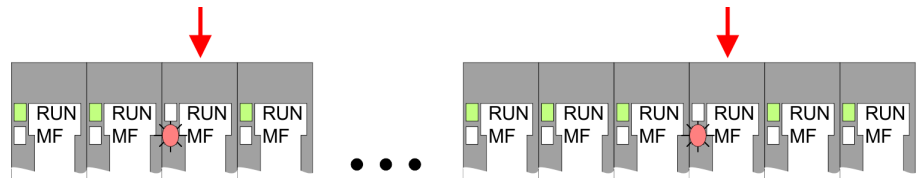

Behaviour: After PowerON the MF LED of one module respectively more modules flashes. The RUN LED remains off.

Reason: At this position a module is placed, which does not correspond to the configured module.

Remedy: Match configuration and hardware structure.

Module failure

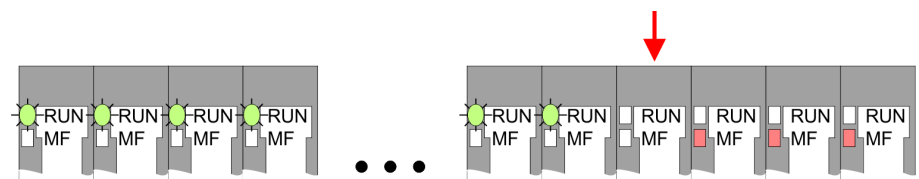

Behaviour: After PowerON all of the RUN LEDs up to the defective module are flashing. With all following modules the MF LED is on and the RUN LED is off.

Reason: The module on the right of the flashing modules is defective.

Remedy: Replace the defective module.

2.8 Installation guidelines

General

The installation guidelines contain information about the interference free deployment of a PLC system. There is the description of the ways, interference may occur in your PLC, how you can make sure the electromagnetic compatibility (EMC), and how you manage the isolation.

- What does EMC mean?** Electromagnetic compatibility (EMC) means the ability of an electrical device, to function error free in an electromagnetic environment without being interfered respectively without interfering the environment.
- The components of VIPA are developed for the deployment in industrial environments and meets high demands on the EMC. Nevertheless you should project an EMC planning before installing the components and take conceivable interference causes into account.
- Possible interference causes** Electromagnetic interferences may interfere your control via different ways:
- Electromagnetic fields (RF coupling)
 - Magnetic fields with power frequency
 - Bus system
 - Power supply
 - Protected earth conductor
- Depending on the spreading medium (lead bound or lead free) and the distance to the interference cause, interferences to your control occur by means of different coupling mechanisms.
- There are:
- galvanic coupling
 - capacitive coupling
 - inductive coupling
 - radiant coupling
- Basic rules for EMC** In the most times it is enough to take care of some elementary rules to guarantee the EMC. Please regard the following basic rules when installing your PLC.
- Take care of a correct area-wide grounding of the inactive metal parts when installing your components.
 - Install a central connection between the ground and the protected earth conductor system.
 - Connect all inactive metal extensive and impedance-low.
 - Please try not to use aluminium parts. Aluminium is easily oxidizing and is therefore less suitable for grounding.
 - When cabling, take care of the correct line routing.
 - Organize your cabling in line groups (high voltage, current supply, signal and data lines).
 - Always lay your high voltage lines and signal respectively data lines in separate channels or bundles.
 - Route the signal and data lines as near as possible beside ground areas (e.g. suspension bars, metal rails, tin cabinet).
 - Proof the correct fixing of the lead isolation.
 - Data lines must be laid isolated.
 - Analog lines must be laid isolated. When transmitting signals with small amplitudes the one sided laying of the isolation may be favourable.
 - Lay the line isolation extensively on an isolation/protected earth conductor rail directly after the cabinet entry and fix the isolation with cable clamps.
 - Make sure that the isolation/protected earth conductor rail is connected impedance-low with the cabinet.
 - Use metallic or metallised plug cases for isolated data lines.

- In special use cases you should appoint special EMC actions.
 - Consider to wire all inductivities with erase links.
 - Please consider luminescent lamps can influence signal lines.
- Create a homogeneous reference potential and ground all electrical operating supplies when possible.
 - Please take care for the targeted employment of the grounding actions. The grounding of the PLC serves for protection and functionality activity.
 - Connect installation parts and cabinets with your PLC in star topology with the isolation/protected earth conductor system. So you avoid ground loops.
 - If there are potential differences between installation parts and cabinets, lay sufficiently dimensioned potential compensation lines.

Isolation of conductors

Electrical, magnetically and electromagnetic interference fields are weakened by means of an isolation, one talks of absorption. Via the isolation rail, that is connected conductive with the rack, interference currents are shunt via cable isolation to the ground. Here you have to make sure, that the connection to the protected earth conductor is impedance-low, because otherwise the interference currents may appear as interference cause.

When isolating cables you have to regard the following:

- If possible, use only cables with isolation tangle.
- The hiding power of the isolation should be higher than 80%.
- Normally you should always lay the isolation of cables on both sides. Only by means of the both-sided connection of the isolation you achieve high quality interference suppression in the higher frequency area. Only as exception you may also lay the isolation one-sided. Then you only achieve the absorption of the lower frequencies. A one-sided isolation connection may be convenient, if:
 - the conduction of a potential compensating line is not possible.
 - analog signals (some mV respectively μA) are transferred.
 - foil isolations (static isolations) are used.
- With data lines always use metallic or metallised plugs for serial couplings. Fix the isolation of the data line at the plug rack. Do not lay the isolation on the PIN 1 of the plug bar!
- At stationary operation it is convenient to strip the insulated cable interruption free and lay it on the isolation/protected earth conductor line.
- To fix the isolation tangles use cable clamps out of metal. The clamps must clasp the isolation extensively and have well contact.
- Lay the isolation on an isolation rail directly after the entry of the cable in the cabinet. Lead the isolation further on to your PLC and don't lay it on there again!



CAUTION!

Please regard at installation!

At potential differences between the grounding points, there may be a compensation current via the isolation connected at both sides.

Remedy: Potential compensation line

2.9 General data

Conformity and approval

Conformity		
CE	2006/95/EG	Low-voltage directive
	2004/108/EG	EMC directive
Approval		
UL	UL 508	Approval for USA and Canada
others		
RoHS	2011/65/EU	Product is lead-free; Restriction of the use of certain hazardous substances in electrical and electronic equipment

Protection of persons and device protection

Type of protection	-	IP20
Electrical isolation		
to the field bus	-	electrically isolated
to the process level	-	electrically isolated
Insulation resistance		-
Insulation voltage to reference earth		
Inputs / outputs	-	AC / DC 50V, test voltage AC 500V
Protective measures	-	against short circuit

Environmental conditions to EN 61131-2

Climatic		
Storage / transport	EN 60068-2-14	-25...+70°C
Operation		
Horizontal installation hanging	EN 61131-2	0...+60°C
Horizontal installation lying	EN 61131-2	0...+55°C
Vertical installation	EN 61131-2	0...+50°C
Air humidity	EN 60068-2-30	RH1 (without condensation, rel. humidity 10...95%)
Pollution	EN 61131-2	Degree of pollution 2
Installation altitude max.	-	2000m
Mechanical		
Oscillation	EN 60068-2-6	1g, 9Hz ... 150Hz
Shock	EN 60068-2-27	15g, 11ms

General data

Mounting conditions

Mounting place	-	In the control cabinet
Mounting position	-	Horizontal and vertical

EMC	Standard	Comment
Emitted interference	EN 61000-6-4	Class A (Industrial area)
Noise immunity zone B	EN 61000-6-2	Industrial area
	EN 61000-4-2	ESD 8kV at air discharge (degree of severity 3), 4kV at contact discharge (degree of severity 2)
	EN 61000-4-3	HF field immunity (casing) 80MHz ... 1000MHz, 10V/m, 80% AM (1kHz) 1.4GHz ... 2.0GHz, 3V/m, 80% AM (1kHz) 2GHz ... 2.7GHz, 1V/m, 80% AM (1kHz)
	EN 61000-4-6	HF conducted 150kHz ... 80MHz, 10V, 80% AM (1kHz)
	EN 61000-4-4	Burst, degree of severity 3
	EN 61000-4-5	Surge, installation class 3 *

*) Due to the high-energetic single pulses with Surge an appropriate external protective circuit with lightning protection elements like conductors for lightning and overvoltage is necessary.

3 Digital Input

3.1 021-1BB00 - DI 2xDC 24V

Properties

The electronic module collects the binary control signals from the process level and transmits them isolated to the central bus system. It has 2 channels and their status is monitored via LEDs.

- 2 digital inputs, isolated to the backplane bus
- Suited for switches and approximate switches
- Status indication of the channels via LEDs also with de-activated electronic power supply

Structure

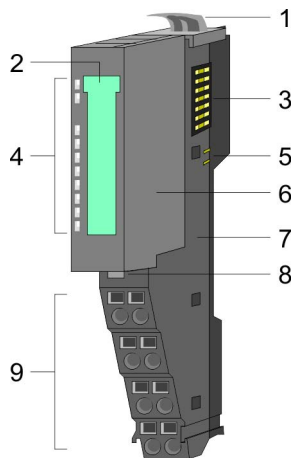

- 1 Locking lever terminal module
- 2 Labeling strip
- 3 Backplane bus
- 4 LED status indication
- 5 DC 24V power section supply
- 6 Electronic module
- 7 Terminal module
- 8 Locking lever electronic module
- 9 Terminal

Status indication

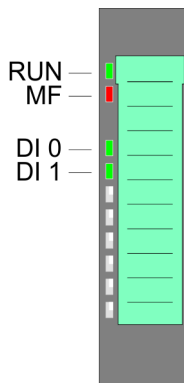

RUN	MF	DI x	Description
green	red	green	
■	■	■	
●	○	X	Bus communication is OK Module status is OK
●	●	X	Bus communication is OK Module status reports an error
○	●	X	Bus communication is not possible Module status reports an error
○	○	X	Error at bus power supply
X	B	X	Error in configuration ↪ <i>Chapter 2.7 'Trouble shooting - LEDs' on page 28</i>
●	○	●	Digital input has signal "1"
●	○	○	Digital input has signal "0"
on: ● off: ○ blinks with 2Hz: B not relevant: X			

Pin assignment

For wires with a cross section of 0.08mm² up to 1.5mm².

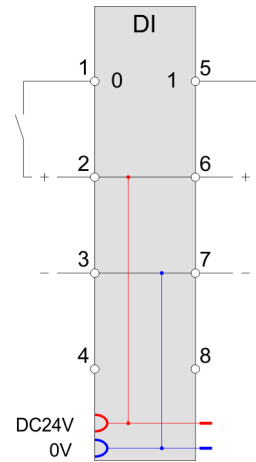
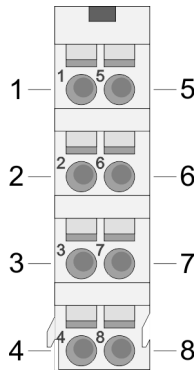

Pos.	Function	Type	Description
1	DI 0	I	Digital input DI 0
2	DC 24V	O	DC 24V for sensor
3	0V	O	GND
4	---	---	not connected
5	DI 1	I	Digital input DI 1
6	DC 24V	O	DC 24V for sensor
7	0V	O	GND
8	---	---	not connected

I: Input, O: Output

Input area

At CPU, PROFIBUS and PROFINET the input area is embedded to the corresponding address area.

IX - Index for access via CANopen

SX - Subindex (6000h + EtherCAT-Slot) for access via EtherCAT

More can be found in the according manual of your bus coupler.

Addr.	Name	Bytes	Function	IX	SX
+0	PII	1	State of the inputs	5000h	
			Bit 0: DI 0		01h
			Bit 1: DI 1		02h
			Bit 7 ... 2: reserved		

Output area

No byte of the output area is used by the module.

3.1.1 Technical data

Order no.	021-1BB00
Type	SM 021
Module ID	0001 9F82
Current consumption/power loss	
Current consumption from backplane bus	55 mA
Power loss	0.5 W
Technical data digital inputs	
Number of inputs	2
Cable length, shielded	1000 m
Cable length, unshielded	600 m
Rated load voltage	-
Current consumption from load voltage L+ (without load)	-
Rated value	DC 20.4...28.8 V
Input voltage for signal "0"	DC 0...5 V
Input voltage for signal "1"	DC 15...28.8 V
Input voltage hysteresis	-
Frequency range	-
Input resistance	-
Input current for signal "1"	3 mA
Connection of Two-Wire-BEROs possible	✓
Max. permissible BERO quiescent current	0.5 mA
Input delay of "0" to "1"	3 ms
Input delay of "1" to "0"	3 ms
Number of simultaneously utilizable inputs horizontal configuration	2
Number of simultaneously utilizable inputs vertical configuration	2
Input characteristic curve	IEC 61131-2, type 1
Initial data size	2 Bit
Status information, alarms, diagnostics	
Status display	green LED per channel
Interrupts	no
Process alarm	no
Diagnostic interrupt	no
Diagnostic functions	no
Diagnostics information read-out	none

Order no.	021-1BB00
Module state	green LED
Module error display	red LED
Channel error display	none
Isolation	
Between channels	-
Between channels of groups to	-
Between channels and backplane bus	✓
Insulation tested with	DC 500 V
Safety	
Safety protocol	-
Safety requirements	-
Secure user address	-
Watchdog	-
Two channels	-
Test pulse outputs	-
Datasizes	
Input bytes	1
Output bytes	0
Parameter bytes	0
Diagnostic bytes	0
Housing	
Material	PPE / PPE GF10
Mounting	Profile rail 35 mm
Mechanical data	
Dimensions (WxHxD)	12.9 mm x 109 mm x 76.5 mm
Weight	60 g
Environmental conditions	
Operating temperature	0 °C to 60 °C
Storage temperature	-25 °C to 70 °C
Certifications	
UL certification	yes

3.2 021-1BB10 - DI 2xDC 24V 2µs...4ms

Properties

The electronic module collects the binary control signals from the process level and transmits them isolated to the central bus system. The module has 2 fast digital input channels and their status is monitored via LEDs.

- 2 fast digital inputs, isolated to the backplane bus
- Suited for switches and approximate switches
- Status indication of the channels via LEDs also with de-activated electronic power supply
- Parameterizable input delay
- Interrupt and diagnostics function

Structure

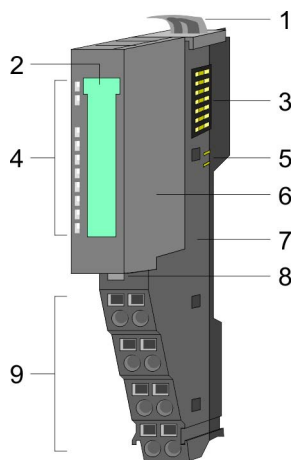

- 1 Locking lever terminal module
- 2 Labeling strip
- 3 Backplane bus
- 4 LED status indication
- 5 DC 24V power section supply
- 6 Electronic module
- 7 Terminal module
- 8 Locking lever electronic module
- 9 Terminal

Status indication

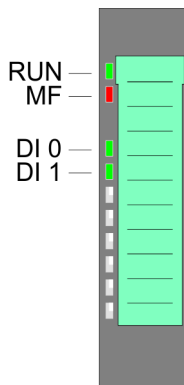

RUN	MF	DI x	Description
green	red	green	
■	■	■	
●	○	X	Bus communication is OK Module status is OK
●	●	X	Bus communication is OK Module status reports an error
○	●	X	Bus communication is not possible Module status reports an error
○	○	X	Error at bus power supply
X	B	X	Error in configuration ↪ <i>Chapter 2.7 'Trouble shooting - LEDs' on page 28</i>
●	○	●	Digital input has signal "1"
●	○	○	Digital input has signal "0"
on: ● off: ○ blinks with 2Hz: B not relevant: X			

Pin assignment

For wires with a cross section of 0.08mm² up to 1.5mm².

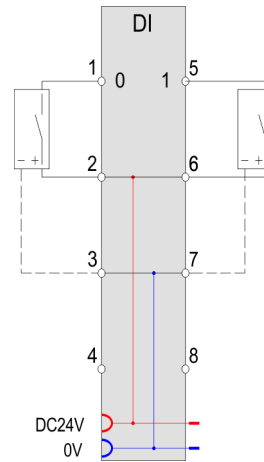
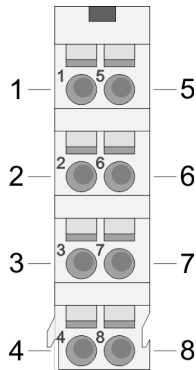

Pos.	Function	Type	Description
1	DI 0	I	Digital input DI 0
2	DC 24V	O	DC 24V for sensor
3	0V	O	GND
4	---	---	not connected
5	DI 1	I	Digital input DI 1
6	DC 24V	O	DC 24V for sensor
7	0V	O	GND
8	---	---	not connected

I: Input, O: Output

Input area

At CPU, PROFIBUS and PROFINET the input area is embedded to the corresponding address area.

IX - Index for access via CANopen

SX - Subindex (6000h + EtherCAT-Slot) for access via EtherCAT

More can be found in the according manual of your bus coupler.

Addr.	Name	Bytes	Function	IX	SX
+0	PII	1	State of the inputs	5000h	
			Bit 0: DI 0		01h
			Bit 1: DI 1		02h
			Bit 7 ... 2: reserved		

Output area

No byte of the output area is used by the module.

3.2.1 Technical data

Order no.	021-1BB10
Type	SM 021
Module ID	000A 1F02
Current consumption/power loss	
Current consumption from backplane bus	95 mA
Power loss	0.9 W
Technical data digital inputs	
Number of inputs	2
Cable length, shielded	1000 m
Cable length, unshielded	600 m
Rated load voltage	DC 20.4...28.8 V
Current consumption from load voltage L+ (without load)	12 mA
Rated value	DC 20.4...28.8 V
Input voltage for signal "0"	DC 0...5 V
Input voltage for signal "1"	DC 15...28.8 V
Input voltage hysteresis	-
Frequency range	-
Input resistance	-
Input current for signal "1"	3 mA
Connection of Two-Wire-BEROs possible	✓
Max. permissible BERO quiescent current	0.5 mA
Input delay of "0" to "1"	parameterizable 2 μ s - 3ms
Input delay of "1" to "0"	parameterizable 2 μ s - 3ms
Number of simultaneously utilizable inputs horizontal configuration	2
Number of simultaneously utilizable inputs vertical configuration	2
Input characteristic curve	IEC 61131-2, type 1
Initial data size	2 Bit
Status information, alarms, diagnostics	
Status display	green LED per channel
Interrupts	yes, parameterizable
Process alarm	yes, parameterizable
Diagnostic interrupt	yes, parameterizable
Diagnostic functions	yes
Diagnostics information read-out	possible

Order no.	021-1BB10
Module state	green LED
Module error display	red LED
Channel error display	none
Isolation	
Between channels	-
Between channels of groups to	-
Between channels and backplane bus	✓
Insulation tested with	DC 500 V
Safety	
Safety protocol	-
Safety requirements	-
Secure user address	-
Watchdog	-
Two channels	-
Test pulse outputs	-
Datasizes	
Input bytes	1
Output bytes	0
Parameter bytes	9
Diagnostic bytes	20
Housing	
Material	PPE / PPE GF10
Mounting	Profile rail 35 mm
Mechanical data	
Dimensions (WxHxD)	12.9 mm x 109 mm x 76.5 mm
Weight	60 g
Environmental conditions	
Operating temperature	0 °C to 60 °C
Storage temperature	-25 °C to 70 °C
Certifications	
UL certification	yes

3.2.2 Parameter data

DS - Record set for access via CPU, PROFIBUS and PROFINET

IX - Index for access via CANopen

SX - Subindex (3100h + EtherCAT-Slot) for access via EtherCAT

More can be found in the according manual of your bus coupler.

Name	Bytes	Function	Default	DS	IX	SX
DIAG_EN	1	Diagnostic interrupt *	00h	00h	3100h	01h
CH0D	1	Input delay DI 0	02h	01h	3101h	02h
CH1D	1	Input delay DI 1	02h	01h	3102h	03h
INTRE	1	Process interrupt at edge 0-1 of DI x	00h	80h	3103h	04h
INTFE	1	Process interrupt at edge 1-0 of DI x	00h	80h	3104h	05h

*) This record set may only be transferred at STOP state.

DIAG_EN Diagnostic interrupt

Byte	Bit 7 ... 0
0	Diagnostic interrupt 00h: disable 40h: enable

- Here you activate res. de-activate the diagnostic function.

CHxD Input delay

Byte	Function	Possible values
0	Input delay DI x	00h: 1µs 07h: 86µs 02h: 3µs 09h: 342µs 04h: 10µs 0Ch: 2731µs
Other values are not permissible!		

- *Input delay* allows you to preset a filter for the corresponding channel. With the help of filters you may e.g. filter signal peaks at a blurred input signal.

INTRE Interrupt edge 0-1

Byte	Bit 7 ... 0
0	Bit 0: Process interrupt at edge 0-1 of DI 0 Bit 1: Process interrupt at edge 0-1 of DI 1 (0: disable, 1: enable) Bit 7 ... 2: reserved

INTFE Interrupt edge 1-0

Byte	Bit 7 ... 0
0	Bit 0: Process interrupt at edge 1-0 of DI 0 Bit 1: Process interrupt at edge 1-0 of DI 1 (0: disable, 1: enable) Bit 7 ... 2: reserved

3.2.3 Diagnostics and interrupt

Event	Process interrupt	Diagnostics interrupt	parameterizable
Edge 0-1 DI x	X	-	X
Edge 1-0 DI x	X	-	X
Diagnostics buffer overflow	-	X	-
Process interrupt lost	-	X	-

Process interrupt

So you may react to asynchronous events, there is the possibility to activate a process interrupt. A process interrupt interrupts the linear program sequence and jumps depending on the master system to a corresponding Interrupt routine. Here you can react to the process interrupt accordingly.

With CANopen the process interrupt data is transferred via an emergency telegram.

Operating with CPU, PROFIBUS and PROFINET the process interrupt data were transferred via diagnostics telegram.

SX - Subindex (5000h) for access via EtherCAT

More can be found in the according manual of your bus coupler.

Name	Bytes	Function	Default	SX
PRIT_A	1	Process interrupt data	00h	02h
PRIT_B	1	State of the inputs	00h	03h
PRIT_US	2	µs ticker	00h	04h ... 05h

PRIT_A Process interrupt data

Byte	Bit 7 ... 0
0	Bit 0: Edge at Digital input DI 0 Bit 1: Edge at Digital input DI 1 Bit 7 ... 2: reserved

PRIT_B State of the inputs

Byte	Bit 7 ... 0
0	State of the inputs at the moment of the process interrupt Bit 0: State Input DI 0 Bit 1: State Input DI 1 Bit 7 ... 2: reserved

PRIT_US µs-Ticker

Byte	Bit 7 ... 0
0 ... 1	Value of the µs ticker at the moment of the process interrupt

µs ticker

In the SLIO module there is a 32 bit timer (µs ticker). With PowerON the timer starts counting with 0. After $2^{32}-1\mu s$ the timer starts with 0 again.

PRIT_US represents the lower 2 byte of the µs ticker value (0 ... $2^{16}-1$).

Diagnostic data

Via the parameterization you may activate a diagnostic interrupt for the module.

With a diagnostics interrupt the module serves for diagnostics data for diagnostic interrupt *incoming*.

As soon as the reason for releasing a diagnostic interrupt is no longer present, the diagnostic interrupt *going* automatically takes place.

All events of a channel between diagnostic interrupt *incoming* and diagnostic interrupt *going* are not stored and get lost.

Within this time window (1. diagnostic interrupt *incoming* until last diagnostic interrupt *going*) the MF-LED of the module is on.

DS - Record set for access via CPU, PROFIBUS and PROFINET. The access happens by DS 01h. Additionally the first 4 bytes may be accessed by DS 00h.

IX - Index for access via CANopen. The access happens by IX 2F01h. Additionally the first 4 bytes may be accessed by IX 2F00h.

SX - Subindex (5005h) for access via EtherCAT.

More can be found in the according manual of your bus coupler.

Name	Bytes	Function	Default	DS	IX	SX
ERR_A	1	Diagnostic	00h	01h	2F01h	02h
MODTYP	1	Module information	1Fh			03h
ERR_C	1	reserved	00h			04h
ERR_D	1	Diagnostic	00h			05h
CHTYP	1	Channel type	70h			06h

Name	Bytes	Function	Default	DS	IX	SX
NUMBIT	1	Number of diagnostics bits per channel	00h			07h
NUMCH	1	Number channels of the module	02h			08h
CHERR	1	Channel error	00h			09h
CH0ERR... CH7ERR	8	reserved	00h			0Ah ... 11h
DIAG_US	4	µs ticker	00h			13h

ERR_A Diagnostic

Byte	Bit 7 ... 0
0	Bit 0: set at module failure Bit 1: reserved Bit 2: set at external error Bit 3: set at channel error Bit 7 ... 4: reserved

MODTYP Modul information

Byte	Bit 7 ... 0
0	Bit 3 ... 0: Module class 1111b Digital module Bit 4: Channel information present Bit 7 ... 5: reserved

ERR_C reserved

Byte	Bit 7 ... 0
0	reserved

ERR_D Diagnostic

Byte	Bit 7 ... 0
0	Bit 2 ... 0: reserved Bit 3: set at internal diagnostics buffer overflow Bit 5 ... 4: reserved Bit 6: Process interrupt lost Bit 7: reserved

CHTYP Channel type

Byte	Bit 7 ... 0
0	Bit 6 ... 0: Channel type 70h: Digital input Bit 7: reserved

NUMBIT Diagnostic bits

Byte	Bit 7 ... 0
0	Number of diagnostics bits of the module per channel (here 00h)

NUMCH Channels

Byte	Bit 7 ... 0
0	Number of channels of the module (here 02h)

CHERR Channel error

Byte	Bit 7 ... 0
0	Bit 0: Edge lost at DI 0 Bit 1: Edge lost at DI 1 Bit 7 ... 2: reserved

CHxERR reserved

Byte	Bit 7 ... 0
0	reserved

DIAG_US μ s ticker

Byte	Bit 7 ... 0
0 ... 3	Value of the μ s ticker at the moment of the diagnostic

 μ s ticker

In the SLIO module there is a 32 bit timer (μ s ticker). With PowerON the timer starts counting with 0. After $2^{32}-1\mu$ s the timer starts with 0 again.

3.3 021-1BB50 - DI 2xDC 24V NPN**Properties**

The electronic module collects the binary control signals from the process level and transmits them isolated to the central bus system. It has 2 channels and their status is monitored via LEDs. An input becomes active as soon as it is connected to ground.

- 2 digital inputs (N switching), isolated to the backplane bus
- Suited for switches and approximate switches
- Status indication of the channels via LEDs also with de-activated electronic power supply

021-1BB50 - DI 2xDC 24V NPN

Structure

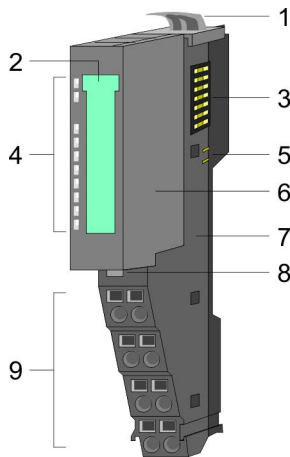

- 1 Locking lever terminal module
- 2 Labeling strip
- 3 Backplane bus
- 4 LED status indication
- 5 DC 24V power section supply
- 6 Electronic module
- 7 Terminal module
- 8 Locking lever electronic module
- 9 Terminal

Status indication

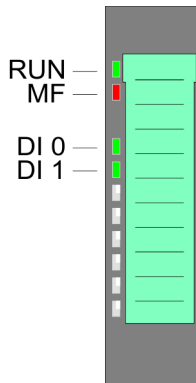

RUN	MF	DI x	Description
green	red	green	
■	■	■	
●	○	X	Bus communication is OK Module status is OK
●	●	X	Bus communication is OK Module status reports an error
○	●	X	Bus communication is not possible Module status reports an error
○	○	X	Error at bus power supply
X	B	X	Error in configuration ↪ <i>Chapter 2.7 'Trouble shooting - LEDs' on page 28</i>
●	○	●	Digital input has signal "1"
●	○	○	Digital input has signal "0"
on: ● off: ○ blinks with 2Hz: B not relevant: X			

Pin assignment

For wires with a cross section of 0.08mm² up to 1.5mm².

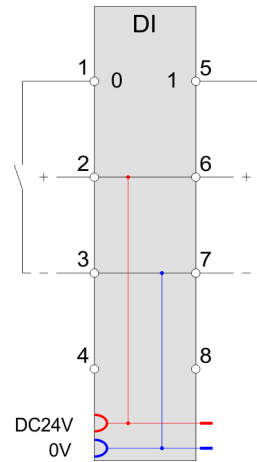
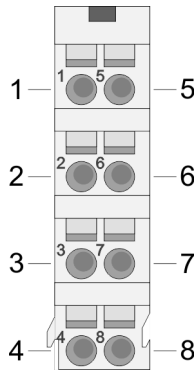

Pos.	Function	Type	Description
1	DI 0	I	Digital input DI 0
2	DC 24V	O	DC 24V for sensor
3	0V	O	GND
4	---	---	not connected
5	DI 1	I	Digital input DI 1
6	DC 24V	O	DC 24V for sensor
7	0V	O	GND
8	---	---	not connected

I: Input, O: Output

Input area

At CPU, PROFIBUS and PROFINET the input area is embedded to the corresponding address area.

IX - Index for access via CANopen

SX - Subindex (6000h + EtherCAT-Slot) for access via EtherCAT

More can be found in the according manual of your bus coupler.

Addr.	Name	Bytes	Function	IX	SX
+0	PII	1	State of the inputs	5000h	
			Bit 0: DI 0		01h
			Bit 1: DI 1		02h
			Bit 7 ... 2: reserved		

Output area

No byte of the output area is used by the module.

3.3.1 Technical data

Order no.	021-1BB50
Type	SM 021
Module ID	0002 9F82
Current consumption/power loss	
Current consumption from backplane bus	60 mA
Power loss	0.5 W
Technical data digital inputs	
Number of inputs	2
Cable length, shielded	1000 m
Cable length, unshielded	600 m
Rated load voltage	-
Current consumption from load voltage L+ (without load)	-
Rated value	DC 20.4...28.8 V
Input voltage for signal "0"	DC 15...28.8 V
Input voltage for signal "1"	DC 0...5 V
Input voltage hysteresis	-
Frequency range	-
Input resistance	-
Input current for signal "1"	3 mA
Connection of Two-Wire-BEROs possible	✓
Max. permissible BERO quiescent current	0.5 mA
Input delay of "0" to "1"	3 ms
Input delay of "1" to "0"	3 ms
Number of simultaneously utilizable inputs horizontal configuration	2
Number of simultaneously utilizable inputs vertical configuration	2
Input characteristic curve	-
Initial data size	2 Bit
Status information, alarms, diagnostics	
Status display	green LED per channel
Interrupts	no
Process alarm	no
Diagnostic interrupt	no
Diagnostic functions	no
Diagnostics information read-out	none

Order no.	021-1BB50
Module state	green LED
Module error display	red LED
Channel error display	none
Isolation	
Between channels	-
Between channels of groups to	-
Between channels and backplane bus	✓
Insulation tested with	DC 500 V
Safety	
Safety protocol	-
Safety requirements	-
Secure user address	-
Watchdog	-
Two channels	-
Test pulse outputs	-
Datasizes	
Input bytes	1
Output bytes	0
Parameter bytes	0
Diagnostic bytes	0
Housing	
Material	PPE / PPE GF10
Mounting	Profile rail 35 mm
Mechanical data	
Dimensions (WxHxD)	12.9 mm x 109 mm x 76.5 mm
Weight	60 g
Environmental conditions	
Operating temperature	0 °C to 60 °C
Storage temperature	-25 °C to 70 °C
Certifications	
UL certification	yes

3.4 021-1BB70 - DI 2xDC 24V ETS

Properties

The electronic module collects the binary control signals from the process level and transmits them isolated to the central bus system. It has 2 channels and their status is monitored via LEDs. With configured ETS functionality (ETS = edge time stamp) and the corresponding (rising/falling) edge the current time value of the μ s timer is stored together with the state of the inputs in the process image. Depending on the configuration 5 (20byte) respectively 15 (60byte) ETS entries may be stored in the process image one after another.

- 2 digital inputs, isolated to the backplane bus
- Configurable ETS functionality for 5 respectively 15 ETS entries (each 4byte)
- Diagnostics function
- Suited for switches and approximate switches
- Status indication of the channels via LEDs also with de-activated electronic power supply

Structure

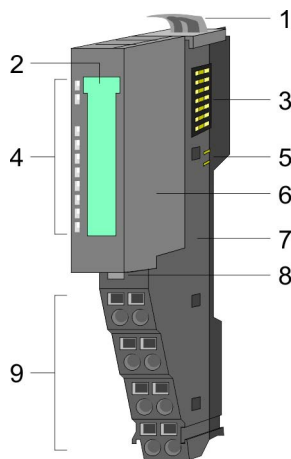

- 1 Locking lever terminal module
- 2 Labeling strip
- 3 Backplane bus
- 4 LED status indication
- 5 DC 24V power section supply
- 6 Electronic module
- 7 Terminal module
- 8 Locking lever electronic module
- 9 Terminal

Status indication

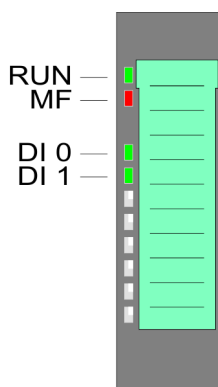

RUN	MF	DI x	Description
green	red	green	
●	○	X	Bus communication is OK Module status is OK
●	●	X	Bus communication is OK Module status reports an error
○	●	X	Bus communication is not possible Module status reports an error
○	○	X	Error at bus power supply
X	B	X	Error in configuration ↪ <i>Chapter 2.7 'Trouble shooting - LEDs' on page 28</i>
●	○	●	Digital input has signal "1"

RUN	MF	DI x	Description
●	○	○	Digital input has signal "0"
on: ● off: ○ blinks with 2Hz: B not relevant: X			

Pin assignment

For wires with a cross section of 0.08mm² up to 1.5mm².

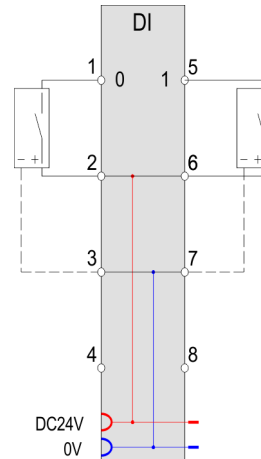
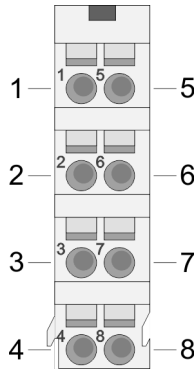

Pos.	Function	Type	Description
1	DI 0	I	Digital input DI 0
2	DC 24V	O	DC 24V for sensor
3	0V	O	GND
4	---	---	not connected
5	DI 1	I	Digital input DI 1
6	DC 24V	O	DC 24V for sensor
7	0V	O	GND
8	---	---	not connected

I: Input, O: Output

In-/Output area

With configured ETS functionality (ETS=edge time stamp) and the corresponding edge the current time value of the SLIO µs timer is stored together with the state of the inputs and a running number as ETS entry in the process image.

You may configure the following variants:

- 021-1BB70 DI 2xDC24V (20): uses 20byte in the PII for 5 ETS entries
- 021-1BB70 DI 2xDC24V (60): uses 60byte in the PII for 15 ETS entries

Output area

No byte of the output area is used by the module.

Input area 20byte respectively 60byte

Depending on the configured variant, the module serves for an area for 5 resp. 15 ETS entries. Each ETS entry uses 4byte in input area:

Input area

The input range is used for status message. At CPU, PROFIBUS and PROFINET the input respectively output area is embedded to the corresponding address area.

IX - IX = Index for access via CANopen. With s = Subindex the corresponding ETS entry is addressed.

SX - Subindex (6000h + EtherCAT-Slot) for access via EtherCAT

More can be found in the according manual of your bus coupler.

Structure of an ETS entry

Addr.	Name	Bytes	Function	IX	SX
+0	PII	1	State of the inputs	5430h/s	01h
+1	RN	1	Running number		02h
+2	ETS_US	2	µs ticker		03h

PII

Here the state of the inputs after an edge change is stored.

The input byte has the following bit assignment:

Bit 0: DI 0

Bit 1: DI 1

Bit 2 ... 7: 0 (fix)

RN

The **Running Number** (RN) is a continuous number 0 ... 127, which starts with 1. The RN corresponds to the chronological order of the edges.

ETS_US

In the SLIO module there is a 32 bit timer (µs ticker). With PowerON the timer starts counting with 0. After $2^{32}-1\mu s$ the timer starts with 0 again.

ETS_US always contains the low word of the µs ticker (0...65535µs).

ETS functionality

With the corresponding edge the value of the timer is stored as ETS entry in the process image as ETS_US together with the state of the inputs PII and the running number RN.

The following figure shows the sequence of how the ETS entries are stored in the input area.

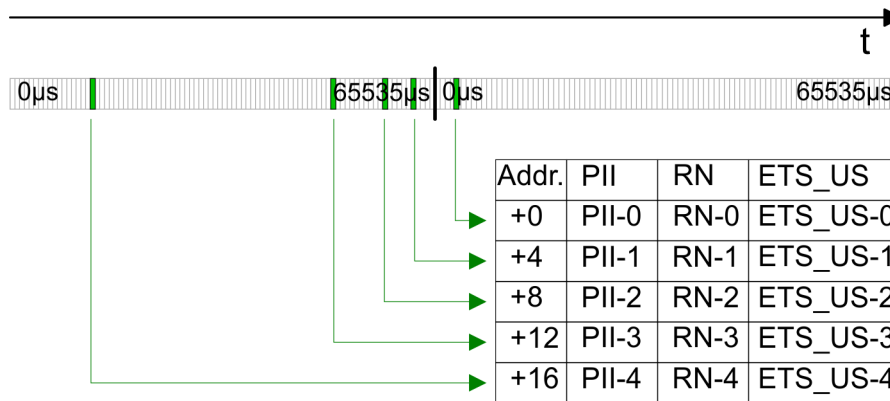

Input area

The input range is used for status message. At CPU, PROFIBUS and PROFINET the input respectively output area is embedded to the corresponding address area.

IX - IX = Index for access via CANopen. With s = Subindex the corresponding ETS entry is addressed.

SX - Subindex (6000h + EtherCAT-Slot) for access via EtherCAT

More can be found in the according manual of your bus coupler.

Configured as 021-1BB70

DI 2xDC 24V (20) 20byte - 5 ETS entries

Addr.	PII	IX=5430h	SX	Addr.	RN	IX=5431h	SX	Addr.	ETS-US	IX=5432h	SX
+0	PII-0	s=1	01h	+1	RN-0	s=1	02h	+2	ETS_US-0	s=1	03h
+4	PII-1	s=2	04h	+5	RN-1	s=2	05h	+6	ETS_US-1	s=2	06h
+8	PII-2	s=3	07h	+9	RN-2	s=3	08h	+10	ETS_US-2	s=3	09h
+12	PII-3	s=4	0Ah	+13	RN-3	s=4	0Bh	+14	ETS_US-3	s=4	0Ch
+16	PII-4	s=5	0Dh	+17	RN-4	s=5	0Eh	+18	ETS_US-4	s=5	0Fh

Configured as 021-1BB70

DI 2xDC 24V (60) 60byte - 15 ETS entries

Addr.	PII	IX=5430h	SX	Addr.	RN	IX=5431h	SX	Addr.	ETS-US	IX=5432h	SX
+0	PII-0	s=1	01h	+1	RN-0	s=1	02h	+2	ETS_US-0	s=1	03h
+4	PII-1	s=2	04h	+5	RN-1	s=2	05h	+6	ETS_US-1	s=2	06h
+8	PII-2	s=3	07h	+9	RN-2	s=3	08h	+10	ETS_US-2	s=3	09h
+12	PII-3	s=4	0Ah	+13	RN-3	s=4	0Bh	+14	ETS_US-3	s=4	0Ch
+16	PII-4	s=5	0Dh	+17	RN-4	s=5	0Eh	+18	ETS_US-4	s=5	0Fh
+20	PII-5	s=6	10h	+21	RN-5	s=6	11h	+22	ETS_US-5	s=6	12h
+24	PII-6	s=7	13h	+25	RN-6	s=7	14h	+26	ETS_US-6	s=7	15h

+28	PII-7	s=8	16h	+29	RN-7	s=8	17h	+30	ETS_US-7	s=8	18h
+32	PII-8	s=9	19h	+33	RN-8	s=9	1Ah	+34	ETS_US-8	s=9	1Bh
+36	PII-9	s=10	1Ch	+37	RN-9	s=10	1Dh	+38	ETS_US-9	s=10	1Eh
+40	PII-10	s=11	1Fh	+41	RN-10	s=11	20h	+42	ETS_US-10	s=11	21h
+44	PII-11	s=12	22h	+45	RN-11	s=12	23h	+46	ETS_US-11	s=12	24h
+48	PII-12	s=13	25h	+49	RN-12	s=13	26h	+50	ETS_US-12	s=13	27h
+52	PII-13	s=14	28h	+53	RN-13	s=14	29h	+54	ETS_US-13	s=14	2Ah
+56	PII-14	s=15	2Bh	+57	RN-14	s=15	2Ch	+58	ETS_US-14	s=15	2Dh



The ETS module may only be accessed by the System SLIO CPU by means of SFC 14 or via the process image.

3.4.1 Technical data

Order no.	021-1BB70
Type	SM 021
Module ID	0F01 47C1
Current consumption/power loss	
Current consumption from backplane bus	85 mA
Power loss	0.9 W
Technical data digital inputs	
Number of inputs	2
Cable length, shielded	1000 m
Cable length, unshielded	600 m
Rated load voltage	DC 24 V
Current consumption from load voltage L+ (without load)	10 mA
Rated value	DC 20.4...28.8 V
Input voltage for signal "0"	DC 0...5 V
Input voltage for signal "1"	DC 15...28.8 V
Input voltage hysteresis	-
Frequency range	-
Input resistance	-
Input current for signal "1"	3 mA
Connection of Two-Wire-BEROs possible	✓
Max. permissible BERO quiescent current	0.5 mA

Order no.	021-1BB70
Input delay of "0" to "1"	parameterizable 2µs - 3ms
Input delay of "1" to "0"	parameterizable 2µs - 3ms
Number of simultaneously utilizable inputs horizontal configuration	2
Number of simultaneously utilizable inputs vertical configuration	2
Input characteristic curve	IEC 61131-2, type 1
Initial data size	60 Byte
Status information, alarms, diagnostics	
Status display	green LED per channel
Interrupts	no
Process alarm	no
Diagnostic interrupt	no
Diagnostic functions	no
Diagnostics information read-out	possible
Module state	green LED
Module error display	red LED
Channel error display	none
Isolation	
Between channels	-
Between channels of groups to	-
Between channels and backplane bus	✓
Insulation tested with	DC 500 V
Safety	
Safety protocol	-
Safety requirements	-
Secure user address	-
Watchdog	-
Two channels	-
Test pulse outputs	-
Datasizes	
Input bytes	20 / 60
Output bytes	0
Parameter bytes	10
Diagnostic bytes	20
Housing	
Material	PPE / PPE GF10

Order no.	021-1BB70
Mounting	Profile rail 35 mm
Mechanical data	
Dimensions (WxHxD)	12.9 mm x 109 mm x 76.5 mm
Weight	60 g
Environmental conditions	
Operating temperature	0 °C to 60 °C
Storage temperature	-25 °C to 70 °C
Certifications	
UL certification	yes

3.4.2 Parameter data

The following variants may be configured:

- 021-1BB70 DI 2xDC24V (20):
uses 20byte in the PII for 5 ETS entries
- 021-1BB70 DI 2xDC24V (60):
uses 60byte in the PII for 15 ETS entries

3.4.2.1 Parameters

DS - Record set for access via CPU, PROFIBUS and PROFINET

IX - Index for access via CANopen

SX - Subindex (3100h + EtherCAT-Slot) for access via EtherCAT

More can be found in the according manual of your bus coupler.

Name	Bytes	Function	Default	DS	IX	SX
PII_L	1	Length process image input data ^{1,2}	14h resp. 3Ch (fix)	02h	3100h	01h
PIQ_L	1	Length process image output data ²	00h (fix)	02h	3101h	02h
CH0D	1	Input delay DI 0	02h	01h	3102h	03h
CH1D	1	Input delay DI 1	02h	01h	3103h	04h
TSER	1	Raising edge 0-1 at DI x	00h	80h	3104h	05h
TSEF	1	Falling edge 1-0 at DI x	00h	80h	3105h	06h

1) This parameter corresponds of the configured variant.

2) This record set may only be transferred at STOP state.

PII_L

Byte	Bit 7 ... 0
0	The length for the process image is fixed adjusted to the length of the parameterized variant (14h or 3Ch).

PIQ_L

Byte	Bit 7 ... 0
0	The length of the process image of the output data is fix set to 0byte.

CHxD DI x

Byte	Description	Possible values	
0	Input delay DI x	00h: 1µs	07h: 86µs
		02h: 3µs	09h: 342µs
		04h: 10µs	0Ch: 2731µs
		Other values are not permissible!	

With the help of filters you may e.g. filter signal peaks at a blurred input signal.

Edge select

Here the ETS function for DI 0 and DI 1 may be activated. With these 2 bytes you may define the type of edge of the input signal, to which the current µs timer value is stored in the process image together with the state of the inputs.

TSER edge 0-1 DI x

Byte	Bit 7 ... 0
0	Bit 0: ETS record at edge 0-1 (rising edge) DI 0 Bit 1: ETS record at edge 0-1 (rising edge) DI 1 (0: disable, 1: enable) Bit 7 ... 2: reserved

TSEF edge 1-0 DI x

Byte	Bit 7 ... 0
0	Bit 0: ETS record at edge 1-0 (falling edge) DI 0 Bit 1: ETS record at edge 1-0 (falling edge) DI 1 (0: disable, 1: enable) Bit 7 ... 2: reserved

3.4.2.2 Example of the principle of operation

In the following it is demonstrated by an example, in which order the ETS entries are stored.

In this example a module is configured, which occupies 20byte for 5 ETS entries.

The following edges for the input channels are preset.

- DI 0: Edge 0-1: ↑

- DI 1: Edge 1-0: ↓

The green area of the diagram indicates the ETS entries, which were available at time "t". ETS entries, which are not (longer) available are marked red.

Process image is empty

New ETS entries are always registered starting from address +0. Thereby already existing ETS entries are shifted 4 byte each.

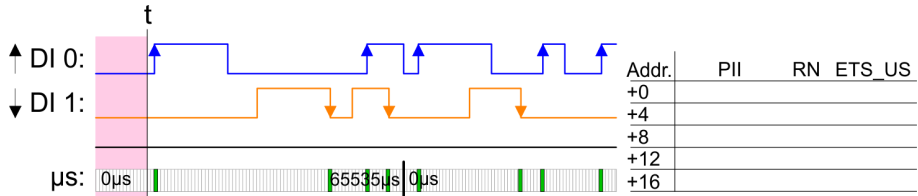

1. ETS entry

Released by an edge 0-1 from DI 0 the 1. ETS entry is registered starting from address +0.

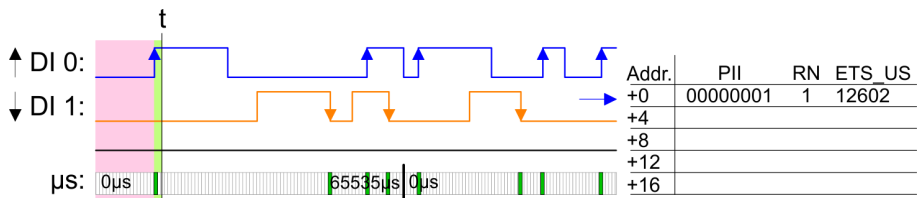

2. ETS entry

Released by an edge 1-0 from DI 1 the 2. ETS entry is registered starting from address +0 and the 1. ETS entry is shifted 4 byte.

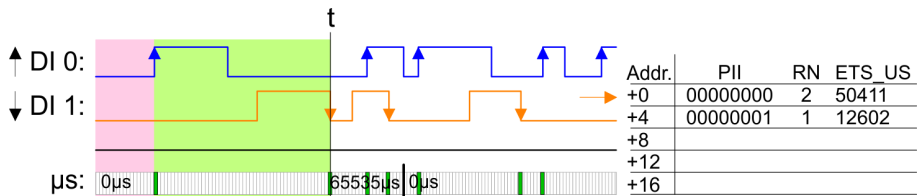

3. ETS entry

Released by an edge 1-0 from DI 1 the 2. ETS entry is registered starting from address +0 and the 1. ETS entry is shifted 4 byte.

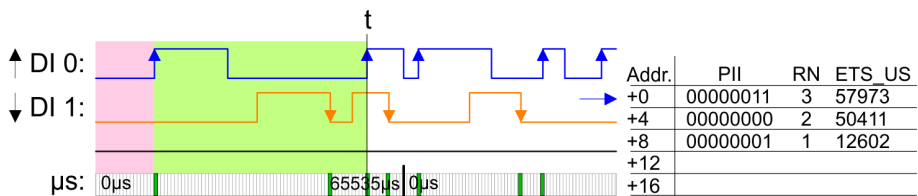

4. ETS entry

Released by an edge 1-0 from DI 1 the 4. ETS entry is registered starting from address +0 and already existing ETS entries are shifted 4 byte each.

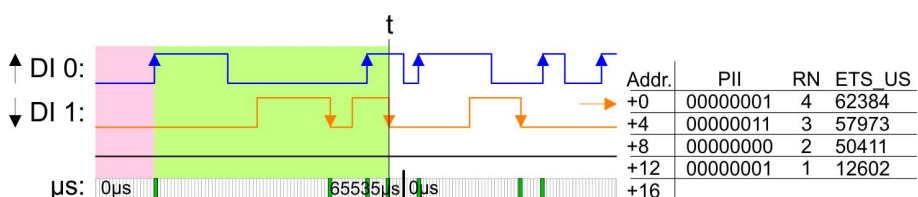

5. ETS entry

Released by an edge 0-1 from DI 0 the 5. ETS entry is registered starting from address +0 and already existing ETS entries are shifted 4 byte each. The maximum number of ETS entries is reached.

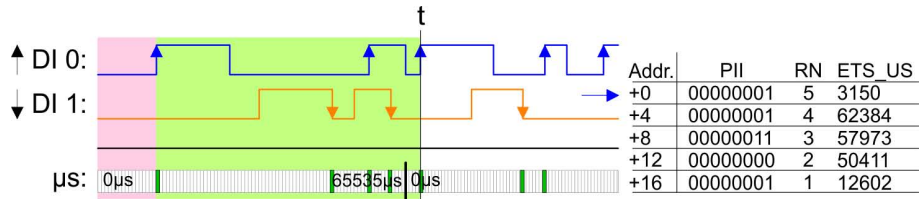

6. ETS entry

Released by an edge 1-0 from DI 1 the 6. ETS entry is registered starting from address +0 and already existing ETS entries are shifted 4 byte each. Thereby the 1. ETS entry is deleted and is not available any longer.

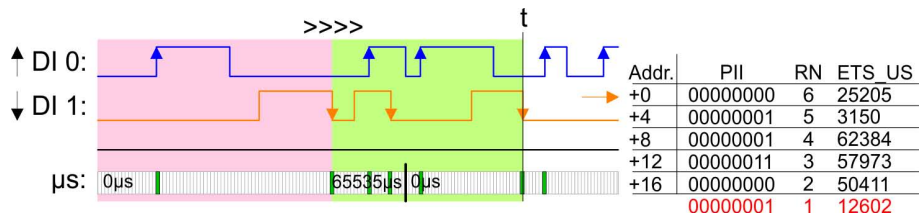

7. ETS entry

Released by an edge 0-1 from DI 0 the 7. ETS entry is registered starting from address +0 and already existing ETS entries are shifted 4 byte each. Thereby the 2. ETS entry is deleted and is not available any longer.

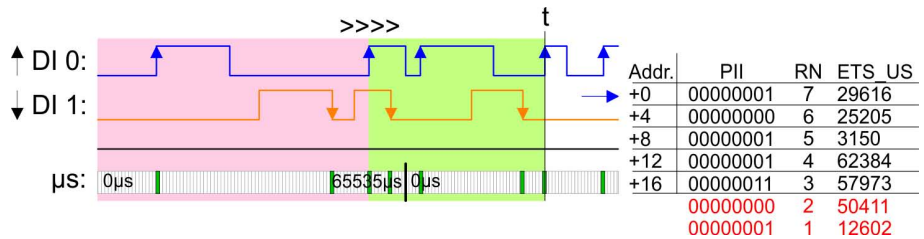

8. ETS entry

Released by an edge 0-1 from DI 0 the 8. ETS entry is registered starting from address +0 and already existing ETS entries are shifted 4 byte each. Thereby the 3. ETS entry is deleted and is not available any longer.

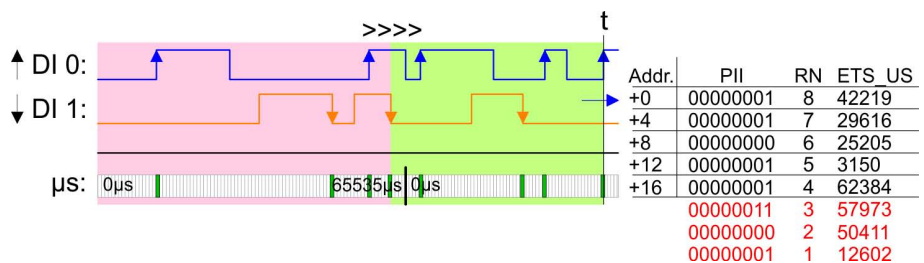

Please consider the ETS modules can only effectively be used together with head modules, which have an integrated μ s ticker. The Ethernet coupler with ModbusTCP 053-1MT00 for example does not have an μ s ticker.

3.4.3 Diagnostic data

So this module does not support interrupt functions, the diagnostic data serve the information about this module.

DS - Record set for access via CPU, PROFIBUS and PROFINET. The access happens by DS 01h. Additionally the first 4 bytes may be accessed by DS 00h.

IX - Index for access via CANopen. The access happens by IX 2F01h. Additionally the first 4 bytes may be accessed by IX 2F00h.

SX - Subindex (5005h) for access via EtherCAT.

More can be found in the according manual of your bus coupler.

Name	Bytes	Function	Default	DS	IX	SX
ERR_A	1	reserved	00h	01h	2F01h	02h
MODTYP	1	Module information	1Fh			03h
ERR_C	1	reserved	00h			04h
ERR_D	1	reserved	00h			05h
CHTYP	1	Channel type	70h			06h
NUMBIT	1	Number of diagnostics bits per channel	00h			07h
NUMCH	1	Number channels of the module	02h			08h
CHERR	1	reserved	00h			09h
CH0ERR... CH7ERR	8	reserved	00h			0Ah ... 11h
DIAG_US	4	µs ticker (32bit)	00h			13h

MODTYP Modul information

Byte	Bit 7 ... 0
0	Bit 3 ... 0: Module class 1111b Digital module Bit 4: Channel information present Bit 7 ... 5: reserved

CHTYP Channel type

Byte	Bit 7 ... 0
0	Bit 6 ... 0: Channel type 70h: Digital input Bit 7: 0 (fix)

NUMBIT Diagnostic bits

Byte	Bit 7 ... 0
0	Number of diagnostics bits of the module per channel (here 00h)

NUMCH channels

Byte	Bit 7 ... 0
0	Number of channels of the module (here 02h)

DIAG_US μ s ticker

Byte	Bit 7 ... 0
0 ... 3	Value of the μ s ticker at the moment of the diagnostic data generation

ERR_A/C/D CHERR, CHxERR reserved

Byte	Bit 7 ... 0
0	reserved

3.5 021-1BD00 - DI 4xDC 24V

Properties

The electronic module collects the binary control signals from the process level and transmits them isolated to the central bus system. It has 4 channels and their status is monitored via LEDs.

- 4 digital inputs, isolated to the backplane bus
- Suited for switches and approximate switches
- Status indication of the channels via LEDs also with de-activated electronic power supply

Structure

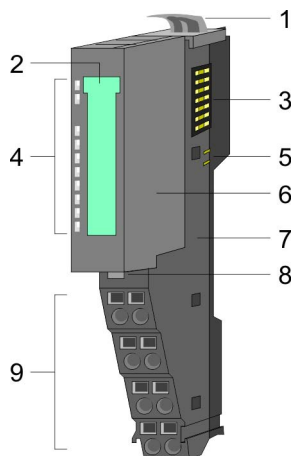

- 1 Locking lever terminal module
- 2 Labeling strip
- 3 Backplane bus
- 4 LED status indication
- 5 DC 24V power section supply
- 6 Electronic module
- 7 Terminal module
- 8 Locking lever electronic module
- 9 Terminal

Status indication

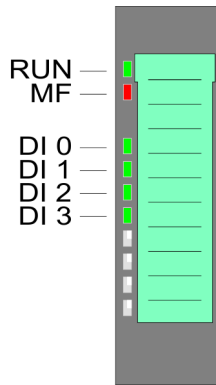

RUN	MF	DI x	Description
green ■	red ■	green ■	
●	○	X	Bus communication is OK Module status is OK
●	●	X	Bus communication is OK Module status reports an error
○	●	X	Bus communication is not possible Module status reports an error
○	○	X	Error at bus power supply
X	B	X	Error in configuration ↪ <i>Chapter 2.7 'Trouble shooting - LEDs' on page 28</i>
●	○	●	Digital input has signal "1"
●	○	○	Digital input has signal "0"
on: ● off: ○ blinks with 2Hz: B not relevant: X			

Pin assignment

For wires with a cross section of 0.08mm² up to 1.5mm².

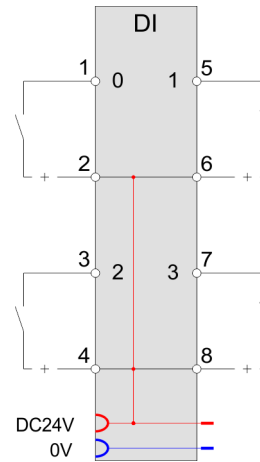
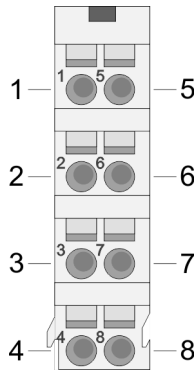

Pos.	Function	Type	Description
1	DI 0	I	Digital input DI 0
2	DC 24V	O	DC 24V for sensor
3	DI 2	I	Digital input DI 2
4	DC 24V	O	DC 24V for sensor
5	DI 1	I	Digital input DI 1
6	DC 24V	O	DC 24V for sensor
7	DI 3	I	Digital input DI 3
8	DC 24V	O	DC 24V for sensor

I: Input, O: Output

Input area

At CPU, PROFIBUS and PROFINET the input area is embedded to the corresponding address area.

IX - Index for access via CANopen

SX - Subindex (6000h + EtherCAT-Slot) for access via EtherCAT

More can be found in the according manual of your bus coupler.

Addr.	Name	Bytes	Function	IX	SX
+0	PII	1	State of the inputs	5000h	
			Bit 0: DI 0		01h
			Bit 1: DI 1		02h
			Bit 2: DI 2		03h
			Bit 3: DI 3		04h
			Bit 7 ... 4: reserved		

Output area

No byte of the output area is used by the module.

3.5.1 Technical data

Order no.	021-1BD00
Type	SM 021
Module ID	0003 9F84
Current consumption/power loss	
Current consumption from backplane bus	55 mA
Power loss	0.6 W
Technical data digital inputs	
Number of inputs	4
Cable length, shielded	1000 m
Cable length, unshielded	600 m
Rated load voltage	-
Current consumption from load voltage L+ (without load)	-
Rated value	DC 20.4...28.8 V
Input voltage for signal "0"	DC 0...5 V
Input voltage for signal "1"	DC 15...28.8 V
Input voltage hysteresis	-
Frequency range	-
Input resistance	-
Input current for signal "1"	3 mA
Connection of Two-Wire-BEROs possible	✓
Max. permissible BERO quiescent current	0.5 mA
Input delay of "0" to "1"	3 ms
Input delay of "1" to "0"	3 ms
Number of simultaneously utilizable inputs horizontal configuration	4
Number of simultaneously utilizable inputs vertical configuration	4
Input characteristic curve	IEC 61131-2, type 1
Initial data size	4 Bit
Status information, alarms, diagnostics	
Status display	green LED per channel
Interrupts	no
Process alarm	no
Diagnostic interrupt	no
Diagnostic functions	no
Diagnostics information read-out	none

Order no.	021-1BD00
Module state	green LED
Module error display	red LED
Channel error display	none
Isolation	
Between channels	-
Between channels of groups to	-
Between channels and backplane bus	✓
Insulation tested with	DC 500 V
Safety	
Safety protocol	-
Safety requirements	-
Secure user address	-
Watchdog	-
Two channels	-
Test pulse outputs	-
Datasizes	
Input bytes	1
Output bytes	0
Parameter bytes	0
Diagnostic bytes	0
Housing	
Material	PPE / PPE GF10
Mounting	Profile rail 35 mm
Mechanical data	
Dimensions (WxHxD)	12.9 mm x 109 mm x 76.5 mm
Weight	60 g
Environmental conditions	
Operating temperature	0 °C to 60 °C
Storage temperature	-25 °C to 70 °C
Certifications	
UL certification	yes

3.6 021-1BD10 - DI 4xDC 24V 2µs...4ms

Properties

The electronic module collects the binary control signals from the process level and transmits them isolated to the central bus system. It has 4 fast digital input channels and their status is monitored via LEDs.

- 4 fast digital inputs, isolated to the backplane bus
- Suited for switches and approximate switches
- Status indication of the channels via LEDs also with de-activated electronic power supply
- Parameterizable input delay
- Interrupt and diagnostics function

Structure

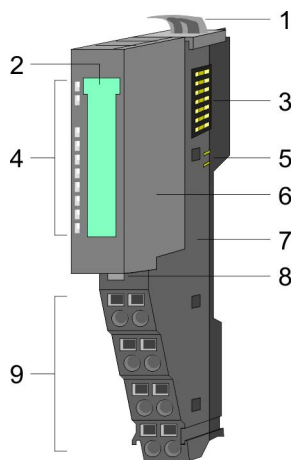

- 1 Locking lever terminal module
- 2 Labeling strip
- 3 Backplane bus
- 4 LED status indication
- 5 DC 24V power section supply
- 6 Electronic module
- 7 Terminal module
- 8 Locking lever electronic module
- 9 Terminal

Status indication

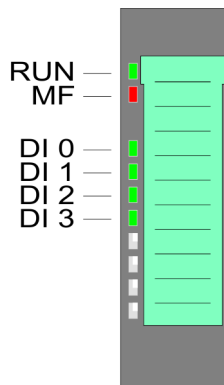

RUN	MF	DI x	Description
green	red	green	
■	■	■	
●	○	X	Bus communication is OK Module status is OK
●	●	X	Bus communication is OK Module status reports an error
○	●	X	Bus communication is not possible Module status reports an error
○	○	X	Error at bus power supply
X	B	X	Error in configuration ↪ <i>Chapter 2.7 'Trouble shooting - LEDs' on page 28</i>
●	○	●	Digital input has signal "1"
●	○	○	Digital input has signal "0"
on: ● off: ○ blinks with 2Hz: B not relevant: X			

Pin assignment

For wires with a cross section of 0.08mm² up to 1.5mm².

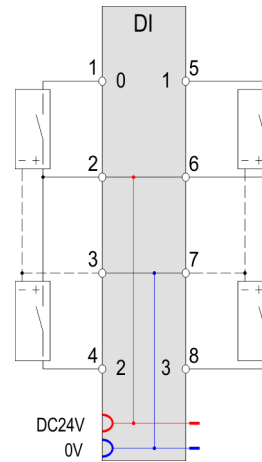
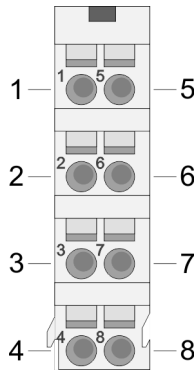

Pos.	Function	Type	Description
1	DI 0	I	Digital input DI 0
2	DC 24V	O	DC 24V for sensor
3	0V	O	GND
4	DI 2	I	Digital input DI 2
5	DI 1	I	Digital input DI 1
6	DC 24V	O	DC 24V for sensor
7	0V	O	GND
8	DI 3	O	Digital input DI 3

I: Input, O: Output

Input area

At CPU, PROFIBUS and PROFINET the input area is embedded to the corresponding address area.

IX - Index for access via CANopen

SX - Subindex (6000h + EtherCAT-Slot) for access via EtherCAT

More can be found in the according manual of your bus coupler.

Addr.	Name	Bytes	Function	IX	SX
+0	PII	1	State of the inputs	5000h	
			Bit 0: DI 0		01h
			Bit 1: DI 1		02h
			Bit 2: DI 2		03h
			Bit 3: DI 3		04h
			Bit 7 ... 4: reserved		

Output area

No byte of the output area is used by the module.

3.6.1 Technical data

Order no.	021-1BD10
Type	SM 021
Module ID	0009 1F04
Current consumption/power loss	
Current consumption from backplane bus	95 mA
Power loss	0.95 W
Technical data digital inputs	
Number of inputs	4
Cable length, shielded	1000 m
Cable length, unshielded	600 m
Rated load voltage	DC 20.4...28.8 V
Current consumption from load voltage L+ (without load)	15 mA
Rated value	DC 20.4...28.8 V
Input voltage for signal "0"	DC 0...5 V
Input voltage for signal "1"	DC 15...28.8 V
Input voltage hysteresis	-
Frequency range	-
Input resistance	-
Input current for signal "1"	3 mA
Connection of Two-Wire-BEROs possible	✓
Max. permissible BERO quiescent current	0.5 mA
Input delay of "0" to "1"	parameterizable 2 μ s - 3ms
Input delay of "1" to "0"	parameterizable 2 μ s - 3ms
Number of simultaneously utilizable inputs horizontal configuration	4
Number of simultaneously utilizable inputs vertical configuration	4
Input characteristic curve	IEC 61131-2, type 1
Initial data size	4 Bit
Status information, alarms, diagnostics	
Status display	green LED per channel
Interrupts	yes, parameterizable
Process alarm	yes, parameterizable
Diagnostic interrupt	yes, parameterizable
Diagnostic functions	yes
Diagnostics information read-out	possible

Order no.	021-1BD10
Module state	green LED
Module error display	red LED
Channel error display	none
Isolation	
Between channels	-
Between channels of groups to	-
Between channels and backplane bus	✓
Insulation tested with	DC 500 V
Safety	
Safety protocol	-
Safety requirements	-
Secure user address	-
Watchdog	-
Two channels	-
Test pulse outputs	-
Datasizes	
Input bytes	1
Output bytes	0
Parameter bytes	11
Diagnostic bytes	20
Housing	
Material	PPE / PPE GF10
Mounting	Profile rail 35 mm
Mechanical data	
Dimensions (WxHxD)	12.9 mm x 109 mm x 76.5 mm
Weight	60 g
Environmental conditions	
Operating temperature	0 °C to 60 °C
Storage temperature	-25 °C to 70 °C
Certifications	
UL certification	yes

3.6.2 Parameter data

DS - Record set for access via CPU, PROFIBUS and PROFINET

IX - Index for access via CANopen

SX - Subindex (3100h + EtherCAT-Slot) for access via EtherCAT

More can be found in the according manual of your bus coupler.

Name	Bytes	Function	Default	DS	IX	SX
DIAG_EN	1	Diagnostic interrupt *	00h	00h	3100h	01h
CH0D	1	Input delay DI 0	02h	01h	3101h	02h
CH1D	1	Input delay DI 1	02h	01h	3102h	03h
CH2D	1	Input delay DI 2	02h	01h	3103h	04h
CH3D	1	Input delay DI 3	02h	01h	3104h	05h
INTRE	1	Diagnostic interrupt at edge 0-1 of DI x	00h	80h	3105h	06h
INTFE	1	Diagnostic interrupt at edge 1-0 of DI x	00h	80h	3106h	07h

*) This record set may only be transferred at STOP state.

DIAG_EN Diagnostic interrupt

Byte	Bit 7 ... 0
0	Diagnostic interrupt 00h: disable 40h: enable

- Here you activate res. de-activate the diagnostic function.

CHxD Input delay

Byte	Function	Possible values
0	Input delay DI x	00h: 1µs 07h: 86µs 02h: 3µs 09h: 342µs 04h: 10µs 0Ch: 2731µs
Other values are not permissible!		

- *Input delay* allows you to preset a filter for the corresponding channel. With the help of filters you may e.g. filter signal peaks at a blurred input signal.

INTRE Interrupt edge 0-1

Byte	Bit 7 ... 0
0	Bit 0: Diagnostic interrupt at edge 0-1 of DI 0 Bit 1: Diagnostic interrupt at edge 0-1 of DI 1 Bit 2: Diagnostic interrupt at edge 0-1 of DI 2 Bit 3: Diagnostic interrupt at edge 0-1 of DI 3 (0: disable, 1: enable) Bit 7 ... 4: reserved

INTFE Interrupt edge 1-0

Byte	Bit 7 ... 0
0	Bit 0: Diagnostic interrupt at edge 1-0 of DI 0 Bit 1: Diagnostic interrupt at edge 1-0 of DI 1 Bit 2: Diagnostic interrupt at edge 1-0 of DI 2 Bit 3: Diagnostic interrupt at edge 1-0 of DI 3 (0: disable, 1: enable) Bit 7 ... 4: reserved

3.6.3 Diagnostics and interrupt

Event	Process interrupt	Diagnostics interrupt	parameterizable
Edge 0-1 DI x	X	-	X
Edge 1-0 DI x	X	-	X
Diagnostics buffer overflow	-	X	-
Process interrupt lost	-	X	-

Process interrupt

So you may react to asynchronous events, there is the possibility to activate a process interrupt. A process interrupt interrupts the linear program sequence and jumps depending on the master system to a corresponding Interrupt routine. Here you can react to the process interrupt accordingly.

With CANopen the process interrupt data a transferred via an emergency telegram.

Operating with CPU, PROFIBUS and PROFINET the process interrupt data were transferred via diagnostics telegram.

SX - Subindex (5000h) for access via EtherCAT

More can be found in the according manual of your bus coupler.

Name	Bytes	Function	Default	SX
PRIT_A	1	Process interrupt data	00h	02h
PRIT_B	1	State of the inputs	00h	03h
PRIT_US	2	µs ticker	00h	04h ... 05h

PRIT_A Process interrupt data

Byte	Bit 7 ... 0
0	Bit 0: Edge at Digital input DI 0 Bit 1: Edge at Digital input DI 1 Bit 2: Edge at Digital input DI 2 Bit 3: Edge at Digital input DI 3 Bit 7 ... 4: reserved

PRIT_B State of the inputs

Byte	Bit 7 ... 0
0	State of the inputs at the moment of the process interrupt Bit 0: State Input DI 0 Bit 1: State Input DI 1 Bit 2: State Input DI 2 Bit 3: State Input DI 3 Bit 7 ... 4: reserved

PRIT_US µs ticker

Byte	Bit 7 ... 0
0 ... 1	Value of the µs ticker at the moment of the process interrupt

µs ticker

In the SLIO module there is a 32 bit timer (µs ticker). With PowerON the timer starts counting with 0. After $2^{32}-1\mu\text{s}$ the timer starts with 0 again.

PRIT_US represents the lower 2 byte of the µs ticker value ($0 \dots 2^{16}-1$).

Diagnostic data

Via the parameterization you may activate a diagnostic interrupt for the module.

With a diagnostics interrupt the module serves for diagnostics data for diagnostic interrupt_{incoming}.

As soon as the reason for releasing a diagnostic interrupt is no longer present, the diagnostic interrupt_{going} automatically takes place.

All events of a channel between diagnostic interrupt_{incoming} and diagnostic interrupt_{going} are not stored and get lost.

Within this time window (1. diagnostic interrupt_{incoming} until last diagnostic interrupt_{going}) the MF-LED of the module is on.

DS - Record set for access via CPU, PROFIBUS and PROFINET. The access happens by DS 01h. Additionally the first 4 bytes may be accessed by DS 00h.

IX - Index for access via CANopen. The access happens by IX 2F01h. Additionally the first 4 bytes may be accessed by IX 2F00h.

SX - Subindex (5005h) for access via EtherCAT.

More can be found in the according manual of your bus coupler.

Name	Bytes	Function	Default	DS	IX	SX
ERR_A	1	Diagnostic	00h	01h	2F01h	02h
MODTYP	1	Module information	1Fh			03h
ERR_C	1	reserved	00h			04h
ERR_D	1	Diagnostic	00h			05h
CHTYP	1	Channel type	70h			06h
NUMBIT	1	Number of diagnostics bits per channel	00h			07h
NUMCH	1	Number channels of the module	04h			08h
CHERR	1	Channel error	00h			09h
CH0ERR... CH7ERR	8	reserved	00h			0Ah ... 11h
DIAG_US	4	µs ticker	00h			13h

ERR_A Diagnostic

Byte	Bit 7 ... 0
0	Bit 0: set at module failure Bit 1: reserved Bit 2: set at external error Bit 3: set at channel error Bit 7 ... 4: reserved

MODTYP Modul information

Byte	Bit 7 ... 0
0	Bit 3 ... 0: Module class 1111b: Digital module Bit 4: Channel information present Bit 7 ... 5: reserved

ERR_C reserved

Byte	Bit 7 ... 0
0	reserved

ERR_D Diagnostic

Byte	Bit 7 ... 0
0	Bit 2 ... 0: reserved Bit 3: set at internal diagnostics buffer overflow Bit 5 ... 4: reserved Bit 6: Process interrupt lost Bit 7: reserved

CHTYP Channel type

Byte	Bit 7 ... 0
0	Bit 6 ... 0: Channel type 70h: Digital input Bit 7: reserved

NUMBIT Diagnostic bits

Byte	Bit 7 ... 0
0	Number of diagnostics bits of the module per channel (here 00h)

NUMCH Channels

Byte	Bit 7 ... 0
0	Number of channels of the module (here 04h)

CHERR Channel error

Byte	Bit 7 ... 0
0	Bit 0: Edge lost at DI 0 Bit 1: Edge lost at DI 1 Bit 2: Edge lost at DI 2 Bit 3: Edge lost at DI 3 Bit 7 ... 4: reserved

CHxERR reserved

Byte	Bit 7 ... 0
0	reserved

DIAG_US µs ticker

Byte	Bit 7 ... 0
0 ... 3	Value of the µs ticker at the moment of the diagnostic

µs ticker

In the SLIO module there is a 32 bit timer (µs ticker). With PowerON the timer starts counting with 0. After $2^{32}-1\mu\text{s}$ the timer starts with 0 again.

3.7 021-1BD40 - DI 4xDC 24V 3 wire

Properties

The electronic module collects the binary control signals from the process level and transmits them isolated to the central bus system. It has 4 channels and their status is monitored via LEDs.

- 4 digital inputs with 3 wire connection, isolated to the backplane bus
- Suited for switches and approximate switches
- Status indication of the channels via LEDs also with de-activated electronic power supply

Structure

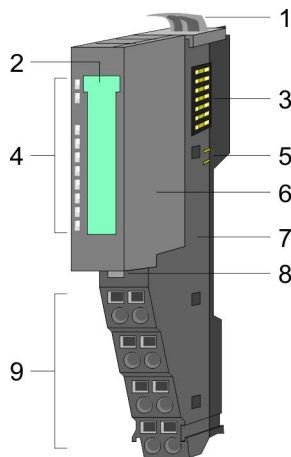

- 1 Locking lever terminal module
- 2 Labeling strip
- 3 Backplane bus
- 4 LED status indication
- 5 DC 24V power section supply
- 6 Electronic module
- 7 Terminal module
- 8 Locking lever electronic module
- 9 Terminal

Status indication

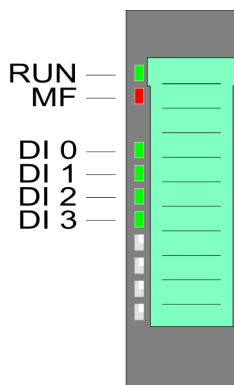

RUN	MF	DI x	Description
green	red	green	
■	■	■	
●	○	X	Bus communication is OK Module status is OK
●	●	X	Bus communication is OK Module status reports an error
○	●	X	Bus communication is not possible Module status reports an error
○	○	X	Error at bus power supply
X	B	X	Error in configuration ↪ <i>Chapter 2.7 'Trouble shooting - LEDs' on page 28</i>
●	○	●	Digital input has signal "1"
●	○	○	Digital input has signal "0"
on: ● off: ○ blinks with 2Hz: B not relevant: X			

Pin assignment

For wires with a cross section of 0.08mm² up to 1.5mm².

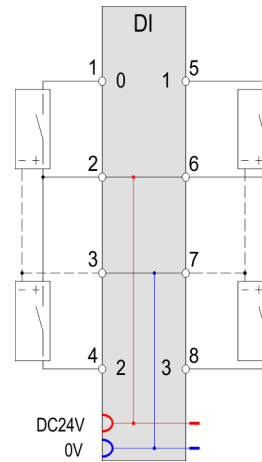
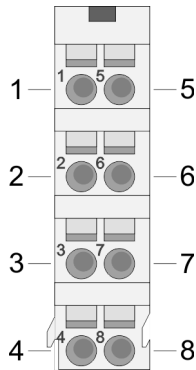

Pos.	Function	Type	Description
1	DI 0	I	Digital input DI 0
2	DC 24V	O	DC 24V for sensor
3	0V	O	GND
4	DI 2	I	Digital input DI 2
5	DI 1	I	Digital input DI 1
6	DC 24V	O	DC 24V for sensor
7	0V	O	GND
8	DI 3	I	Digital input DI 3

I: Input, O: Output

Input area

At CPU, PROFIBUS and PROFINET the input area is embedded to the corresponding address area.

IX - Index for access via CANopen

SX - Subindex (6000h + EtherCAT-Slot) for access via EtherCAT

More can be found in the according manual of your bus coupler.

Addr.	Name	Bytes	Function	IX	SX
+0	PII	1	State of the inputs	5000h	
			Bit 0: DI 0		01h
			Bit 1: DI 1		02h
			Bit 2: DI 2		03h
			Bit 3: DI 3		04h
			Bit 7 ... 4: reserved		

Output area

No byte of the output area is used by the module.

3.7.1 Technical data

Order no.	021-1BD40
Type	SM 021
Module ID	0008 9F84
Current consumption/power loss	
Current consumption from backplane bus	55 mA
Power loss	0.6 W
Technical data digital inputs	
Number of inputs	4
Cable length, shielded	1000 m
Cable length, unshielded	600 m
Rated load voltage	-
Current consumption from load voltage L+ (without load)	-
Rated value	DC 20.4...28.8 V
Input voltage for signal "0"	DC 0...5 V
Input voltage for signal "1"	DC 15...28.8 V
Input voltage hysteresis	-
Frequency range	-
Input resistance	-
Input current for signal "1"	3 mA
Connection of Two-Wire-BEROs possible	✓
Max. permissible BERO quiescent current	0.5 mA
Input delay of "0" to "1"	3 ms
Input delay of "1" to "0"	3 ms
Number of simultaneously utilizable inputs horizontal configuration	4
Number of simultaneously utilizable inputs vertical configuration	4
Input characteristic curve	IEC 61131-2, type 1
Initial data size	4 Bit
Status information, alarms, diagnostics	
Status display	green LED per channel
Interrupts	no
Process alarm	no
Diagnostic interrupt	no
Diagnostic functions	no
Diagnostics information read-out	none

Order no.	021-1BD40
Module state	green LED
Module error display	red LED
Channel error display	none
Isolation	
Between channels	-
Between channels of groups to	-
Between channels and backplane bus	✓
Insulation tested with	DC 500 V
Safety	
Safety protocol	-
Safety requirements	-
Secure user address	-
Watchdog	-
Two channels	-
Test pulse outputs	-
Datasizes	
Input bytes	1
Output bytes	0
Parameter bytes	0
Diagnostic bytes	0
Housing	
Material	PPE / PPE GF10
Mounting	Profile rail 35 mm
Mechanical data	
Dimensions (WxHxD)	12.9 mm x 109 mm x 76.5 mm
Weight	60 g
Environmental conditions	
Operating temperature	0 °C to 60 °C
Storage temperature	-25 °C to 70 °C
Certifications	
UL certification	yes

3.8 021-1BD50 - DI 4xDC 24V NPN

Properties

The electronic module collects the binary control signals from the process level and transmits them isolated to the central bus system. It has 4 channels and their status is monitored via LEDs. An input becomes active as soon as it is connected to ground.

- 4 digital inputs (N switching), isolated to the backplane bus
- Suited for switches and approximate switches
- Status indication of the channels via LEDs also with de-activated electronic power supply

Structure

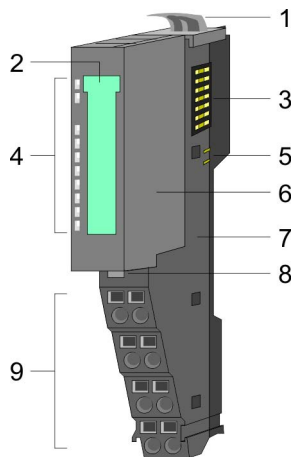

- 1 Locking lever terminal module
- 2 Labeling strip
- 3 Backplane bus
- 4 LED status indication
- 5 DC 24V power section supply
- 6 Electronic module
- 7 Terminal module
- 8 Locking lever electronic module
- 9 Terminal

Status indication

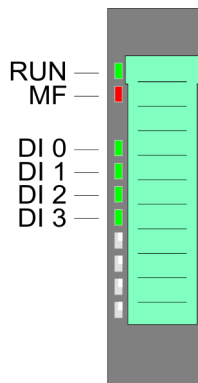

RUN	MF	DI x	Description
green	red	green	
■	■	■	
●	○	X	Bus communication is OK Module status is OK
●	●	X	Bus communication is OK Module status reports an error
○	●	X	Bus communication is not possible Module status reports an error
○	○	X	Error at bus power supply
X	B	X	Error in configuration ↪ <i>Chapter 2.7 'Trouble shooting - LEDs' on page 28</i>
●	○	●	Digital input has signal "1"
●	○	○	Digital input has signal "0"
on: ● off: ○ blinks with 2Hz: B not relevant: X			

Pin assignment

For wires with a cross section of 0.08mm² up to 1.5mm².

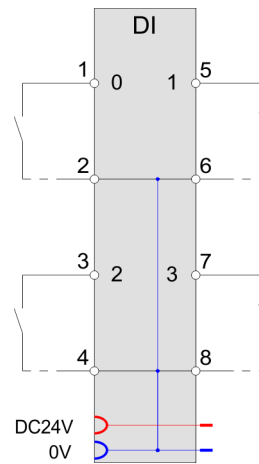
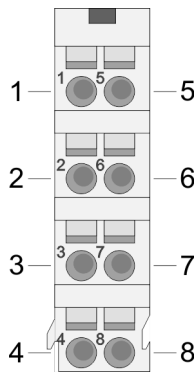

Pos.	Function	Type	Description
1	DI 0	I	Digital input DI 0
2	0V	O	GND
3	DI 2	I	Digital input DI 2
4	0V	O	GND
5	DI 1	I	Digital input DI 1
6	0V	O	GND
7	DI 3	I	Digital input DI 3
8	0V	O	GND

I: Input, O: Output

Input area

At CPU, PROFIBUS and PROFINET the input area is embedded to the corresponding address area.

IX - Index for access via CANopen

SX - Subindex (6000h + EtherCAT-Slot) for access via EtherCAT

More can be found in the according manual of your bus coupler.

Addr.	Name	Bytes	Function	IX	SX
+0	PII	1	State of the inputs	5000h	
			Bit 0: DI 0		01h
			Bit 1: DI 1		02h
			Bit 2: DI 2		03h
			Bit 3: DI 3		04h
			Bit 7 ... 4: reserved		

Output area

No byte of the output area is used by the module.

3.8.1 Technical data

Order no.	021-1BD50
Type	SM 021
Module ID	0004 9F84
Current consumption/power loss	
Current consumption from backplane bus	65 mA
Power loss	0.6 W
Technical data digital inputs	
Number of inputs	4
Cable length, shielded	1000 m
Cable length, unshielded	600 m
Rated load voltage	-
Current consumption from load voltage L+ (without load)	-
Rated value	DC 20.4...28.8 V
Input voltage for signal "0"	DC 15...28.8 V
Input voltage for signal "1"	DC 0...5 V
Input voltage hysteresis	-
Frequency range	-
Input resistance	-
Input current for signal "1"	3 mA
Connection of Two-Wire-BEROs possible	✓
Max. permissible BERO quiescent current	0.5 mA
Input delay of "0" to "1"	3 ms
Input delay of "1" to "0"	3 ms
Number of simultaneously utilizable inputs horizontal configuration	4
Number of simultaneously utilizable inputs vertical configuration	4
Input characteristic curve	-
Initial data size	4 Bit
Status information, alarms, diagnostics	
Status display	green LED per channel
Interrupts	no
Process alarm	no
Diagnostic interrupt	no
Diagnostic functions	no
Diagnostics information read-out	none

Order no.	021-1BD50
Module state	green LED
Module error display	red LED
Channel error display	none
Isolation	
Between channels	-
Between channels of groups to	-
Between channels and backplane bus	✓
Insulation tested with	DC 500 V
Safety	
Safety protocol	-
Safety requirements	-
Secure user address	-
Watchdog	-
Two channels	-
Test pulse outputs	-
Datasizes	
Input bytes	1
Output bytes	0
Parameter bytes	0
Diagnostic bytes	0
Housing	
Material	PPE / PPE GF10
Mounting	Profile rail 35 mm
Mechanical data	
Dimensions (WxHxD)	12.9 mm x 109 mm x 76.5 mm
Weight	60 g
Environmental conditions	
Operating temperature	0 °C to 60 °C
Storage temperature	-25 °C to 70 °C
Certifications	
UL certification	yes

3.9 021-1BD70 - DI 4xDC 24V ETS

Properties

The electronic module collects the binary control signals from the process level and transmits them isolated to the central bus system. It has 4 channels and their status is monitored via LEDs. With configured ETS functionality (ETS = edge time stamp) and the corresponding (rising/falling) edge the current time value of the μ s timer is stored together with the state of the inputs in the process image. Depending on the configuration 5 (20byte) respectively 15 (60byte) ETS entries may be stored in the process image one after another.

- 4 digital inputs, isolated to the backplane bus
- Configurable ETS functionality for 5 respectively 15 ETS entries (each 4byte)
- Diagnostics function
- Suited for switches and approximate switches
- Status indication of the channels via LEDs also with de-activated electronic power supply

Structure

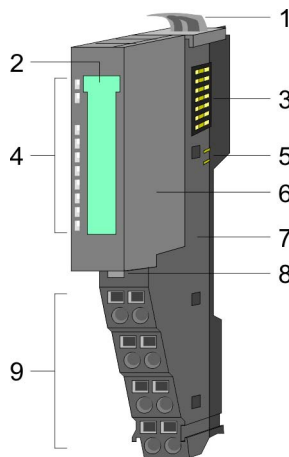

- 1 Locking lever terminal module
- 2 Labeling strip
- 3 Backplane bus
- 4 LED status indication
- 5 DC 24V power section supply
- 6 Electronic module
- 7 Terminal module
- 8 Locking lever electronic module
- 9 Terminal

Status indication

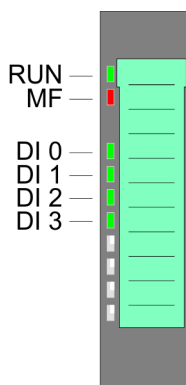

RUN	MF	DI x	Description
green	red	green	
■	■	■	
●	○	X	Bus communication is OK Module status is OK
●	●	X	Bus communication is OK Module status reports an error
○	●	X	Bus communication is not possible Module status reports an error
○	○	X	Error at bus power supply
X	B	X	Error in configuration ↪ Chapter 2.7 'Trouble shooting - LEDs' on page 28
●	○	●	Digital input has signal "1"

RUN	MF	DI x	Description
●	○	○	Digital input has signal "0"
on: ● off: ○ blinks with 2Hz: B not relevant: X			

Pin assignment

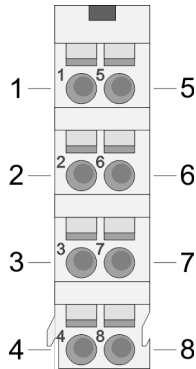

For wires with a cross section of 0.08mm² up to 1.5mm².

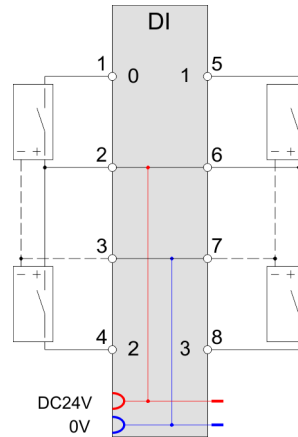

Pos.	Function	Type	Description
1	DI 0	I	Digital input DI 0
2	DC 24V	O	DC 24V for sensor
3	0V	O	GND
4	DI 2	I	Digital input DI 2
5	DI 1	I	Digital input DI 1
6	DC 24V	O	DC 24V for sensor
7	0V	O	GND
8	DI 3	I	Digital input DI 3

I: Input, O: Output

In-/Output area

With configured ETS functionality (ETS=edge time stamp) and the corresponding edge the current time value of the SLIO μs timer is stored together with the state of the inputs and a running number as ETS entry in the process image.

You may configure the following variants:

- 021-1BD70 DI 4xDC24V (20): uses 20byte in the PII for 5 ETS entries
- 021-1BD70 DI 4xDC24V (60): uses 60byte in the PII for 15 ETS entries

Output area

No byte of the output area is used by the module.

Input area 20byte respectively 60byte

Depending on the configured variant, the module serves for an area for 5 resp. 15 ETS entries. Each ETS entry uses 4byte in input area:

Input area

The input range is used for status message. At CPU, PROFIBUS and PROFINET the input respectively output area is embedded to the corresponding address area.

IX - IX = Index for access via CANopen. With s = Subindex the corresponding ETS entry is addressed.

SX - Subindex (6000h + EtherCAT-Slot) for access via EtherCAT

More can be found in the according manual of your bus coupler.

Structure of an ETS entry

Addr.	Name	Bytes	Function	IX	SX
+0	PII	1	State of the inputs	5430h/s	01h
+1	RN	1	Running number		02h
+2	ETS_US	2	µs ticker		03h

PII

Here the state of the inputs after an edge change is stored.

The input byte has the following bit assignment:

Bit 0: DI 0

Bit 1: DI 1

Bit 2: DI 2

Bit 3: DI 3

Bit 4 ... 7: 0 (fix)

RN

The **R**unning **N**umber (RN) is a continuous number 0 ... 127, which starts with 1. The RN corresponds to the chronological order of the edges.

ETS_US

In the SLIO module there is a 32 bit timer (µs ticker). With PowerON the timer starts counting with 0. After $2^{32}-1\mu\text{s}$ the timer starts with 0 again.

ETS_US always contains the low word of the µs ticker (0...65535µs).

ETS functionality

With the corresponding edge the value of the timer is stored as ETS entry in the process image as ETS_US together with the state of the inputs PII and the running number RN.

The following figure shows the sequence of how the ETS entries are stored in the input area.

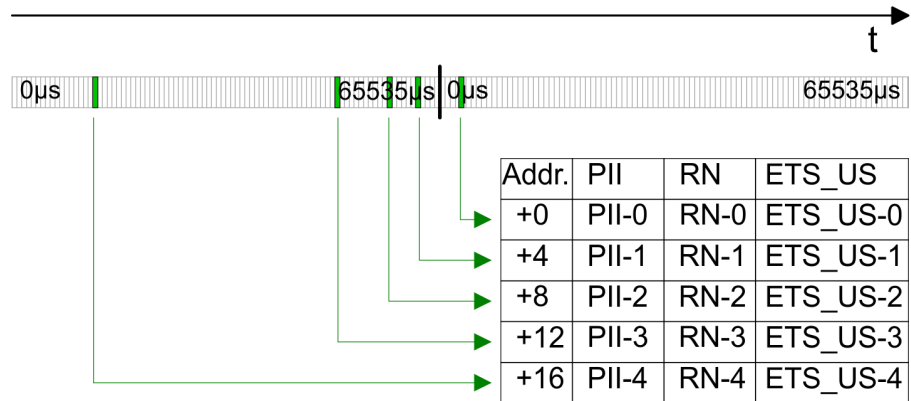

Input area

The input range is used for status message. At CPU, PROFIBUS and PROFINET the input respectively output area is embedded to the corresponding address area.

IX - IX = Index for access via CANopen. With s = Subindex the corresponding ETS entry is addressed.

SX - Subindex (6000h + EtherCAT-Slot) for access via EtherCAT

More can be found in the according manual of your bus coupler.

Configured as 021-1BD70

DI 4xDC 24V (20) 20byte - 5 ETS entries

Addr.	PII	IX=5430h	SX	Addr.	RN	IX=5431h	SX	Addr.	ETS-US	IX=5432h	SX
+0	PII-0	s=1	01h	+1	RN-0	s=1	02h	+2	ETS_US-0	s=1	03h
+4	PII-1	s=2	04h	+5	RN-1	s=2	05h	+6	ETS_US-1	s=2	06h
+8	PII-2	s=3	07h	+9	RN-2	s=3	08h	+10	ETS_US-2	s=3	09h
+12	PII-3	s=4	0Ah	+13	RN-3	s=4	0Bh	+14	ETS_US-3	s=4	0Ch
+16	PII-4	s=5	0Dh	+17	RN-4	s=5	0Eh	+18	ETS_US-4	s=5	0Fh

Configured as 021-1BD70

DI 4xDC 24V (60) 60byte - 15 ETS entries

Addr.	PII	IX=5430h	SX	Addr.	RN	IX=5431h	SX	Addr.	ETS-US	IX=5432h	SX
+0	PII-0	s=1	01h	+1	RN-0	s=1	02h	+2	ETS_US-0	s=1	03h
+4	PII-1	s=2	04h	+5	RN-1	s=2	05h	+6	ETS_US-1	s=2	06h
+8	PII-2	s=3	07h	+9	RN-2	s=3	08h	+10	ETS_US-2	s=3	09h
+12	PII-3	s=4	0Ah	+13	RN-3	s=4	0Bh	+14	ETS_US-3	s=4	0Ch
+16	PII-4	s=5	0Dh	+17	RN-4	s=5	0Eh	+18	ETS_US-4	s=5	0Fh
+20	PII-5	s=6	10h	+21	RN-5	s=6	11h	+22	ETS_US-5	s=6	12h
+24	PII-6	s=7	13h	+25	RN-6	s=7	14h	+26	ETS_US-6	s=7	15h

+28	PII-7	s=8	16h	+29	RN-7	s=8	17h	+30	ETS_US-7	s=8	18h
+32	PII-8	s=9	19h	+33	RN-8	s=9	1Ah	+34	ETS_US-8	s=9	1Bh
+36	PII-9	s=10	1Ch	+37	RN-9	s=10	1Dh	+38	ETS_US-9	s=10	1Eh
+40	PII-10	s=11	1Fh	+41	RN-10	s=11	20h	+42	ETS_US-10	s=11	21h
+44	PII-11	s=12	22h	+45	RN-11	s=12	23h	+46	ETS_US-11	s=12	24h
+48	PII-12	s=13	25h	+49	RN-12	s=13	26h	+50	ETS_US-12	s=13	27h
+52	PII-13	s=14	28h	+53	RN-13	s=14	29h	+54	ETS_US-13	s=14	2Ah



The ETS module may only be accessed by the System SLIO CPU by means of SFC 14 or via the process image.

3.9.1 Technical data

Order no.	021-1BD70
Type	SM 021
Module ID	0F03 47C2
Current consumption/power loss	
Current consumption from backplane bus	85 mA
Power loss	0.95 W
Technical data digital inputs	
Number of inputs	4
Cable length, shielded	1000 m
Cable length, unshielded	600 m
Rated load voltage	DC 24 V
Current consumption from load voltage L+ (without load)	15 mA
Rated value	DC 20.4...28.8 V
Input voltage for signal "0"	DC 0...5 V
Input voltage for signal "1"	DC 15...28.8 V
Input voltage hysteresis	-
Frequency range	-
Input resistance	-
Input current for signal "1"	3 mA
Connection of Two-Wire-BEROs possible	✓
Max. permissible BERO quiescent current	0.5 mA
Input delay of "0" to "1"	parameterizable 2 μ s - 3ms

Order no.	021-1BD70
Input delay of "1" to "0"	parameterizable 2µs - 3ms
Number of simultaneously utilizable inputs horizontal configuration	4
Number of simultaneously utilizable inputs vertical configuration	4
Input characteristic curve	IEC 61131-2, type 1
Initial data size	60 Byte
Status information, alarms, diagnostics	
Status display	green LED per channel
Interrupts	no
Process alarm	no
Diagnostic interrupt	no
Diagnostic functions	no
Diagnostics information read-out	possible
Module state	green LED
Module error display	red LED
Channel error display	none
Isolation	
Between channels	-
Between channels of groups to	-
Between channels and backplane bus	✓
Insulation tested with	DC 500 V
Safety	
Safety protocol	-
Safety requirements	-
Secure user address	-
Watchdog	-
Two channels	-
Test pulse outputs	-
Datasizes	
Input bytes	20 / 60
Output bytes	0
Parameter bytes	12
Diagnostic bytes	20
Housing	
Material	PPE / PPE GF10
Mounting	Profile rail 35 mm

Order no.	021-1BD70
Mechanical data	
Dimensions (WxHxD)	12.9 mm x 109 mm x 76.5 mm
Weight	60 g
Environmental conditions	
Operating temperature	0 °C to 60 °C
Storage temperature	-25 °C to 70 °C
Certifications	
UL certification	yes

3.9.2 Parameter data

The following variants may be configured:

- 021-1BD70 DI 4xDC24V (20):
uses 20byte in the PII for 5 ETS entries
- 021-1BD70 DI 4xDC24V (60):
uses 60byte in the PII for 15 ETS entries

3.9.2.1 Parameters

DS - Record set for access via CPU, PROFIBUS and PROFINET

IX - Index for access via CANopen

SX - Subindex (3100h + EtherCAT-Slot) for access via EtherCAT

More can be found in the according manual of your bus coupler.

Name	Bytes	Function	Default	DS	IX	SX
PII_L	1	Length process image input data ^{1, 2}	14h resp. 3Ch (fix)	02h	3100h	01h
PIQ_L	1	Length process image output data ²	00h (fix)	02h	3101h	02h
CH0D	1	Input delay DI 0	02h	01h	3102h	03h
CH1D	1	Input delay DI 1	02h	01h	3103h	04h
CH2D	1	Input delay DI 2	02h	01h	3104h	05h
CH3D	1	Input delay DI 3	02h	01h	3105h	06h
TSER	1	Raising edge 0-1 at DI x	00h	80h	3106h	07h
TSEF	1	Falling edge 1-0 at DI x	00h	80h	3107h	08h

1) This parameter corresponds of the configured variant.

2) This record set may only be transferred at STOP state.

PII_L

Byte	Bit 7 ... 0
0	The length of the process image of the input data is fix set to the configured variant (14h or 3Ch).

PIQ_L

Byte	Bit 7 ... 0
0	The length of the process image of the output data is fix set to 0 byte.

CHxD DI x

Byte	Description	Possible values	
0	Input delay DI x	00h: 1µs	07h: 86µs
		02h: 3µs	09h: 342µs
		04h: 10µs	0Ch: 2731µs
		Other values are not permissible!	

With the help of filters you may e.g. filter signal peaks at a blurred input signal.

Edge select

Here the ETS function for DI 0 ... DI 3 may be activated. With these 2 bytes you may define the type of edge of the input signal, to which the current µs timer value is stored in the process image together with the state of the inputs.

TSER edge 0-1 DI x

Byte	Bit 7 ... 0
0	Bit 0: ETS record at edge 0-1 (rising edge) DI 0 Bit 1: ETS record at edge 0-1 (rising edge) DI 1 Bit 2: ETS record at edge 0-1 (rising edge) DI 2 Bit 3: ETS record at edge 0-1 (rising edge) DI 3 (0: disable, 1: enable) Bit 7 ... 4: reserved

TSEF edge 1-0 DI x

Byte	Bit 7 ... 0
0	Bit 0: ETS record at edge 1-0 (falling edge) DI 0 Bit 1: ETS record at edge 1-0 (falling edge) DI 1 Bit 2: ETS record at edge 1-0 (falling edge) DI 2 Bit 3: ETS record at edge 1-0 (falling edge) DI 3 (0: disable, 1: enable) Bit 7 ... 4: reserved

3.9.2.2 Example of the principle of operation

In the following it is demonstrated by an example, in which order the ETS entries are stored.

In this example a module is configured, which occupies 20byte for 5 ETS entries.

The following edges for the input channels are preset.

- DI 0: Edge 0-1: ↑
- DI 1: Edge 1-0: ↓
- DI 2 and DI 3 are 0 constant

Process image is empty

New ETS entries are always registered starting from address +0. Thereby already existing ETS entries are shifted 4 byte each.

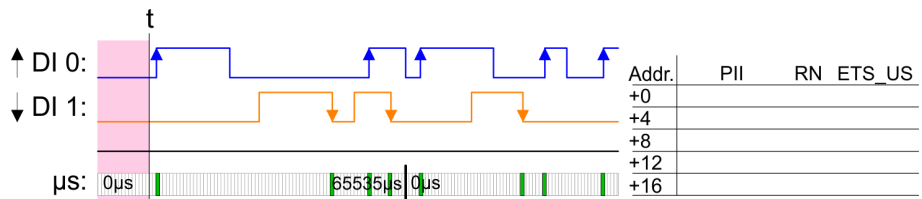

1. ETS entry

Released by an edge 0-1 from DI 0 the 1. ETS entry is registered starting from address +0.

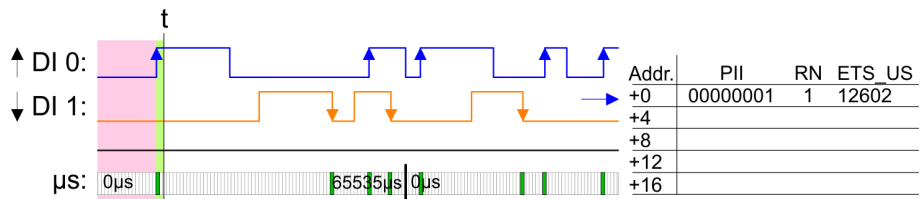

2. ETS entry

Released by an edge 1-0 from DI 1 the 2. ETS entry is registered starting from address +0 and the 1. ETS entry is shifted 4 byte.

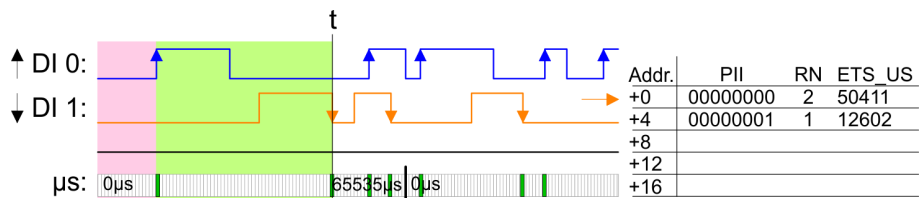

3. ETS entry

Released by an edge 0-1 from DI 0 the 3. ETS entry is registered starting from address +0 and already existing ETS entries are shifted 4 byte each.

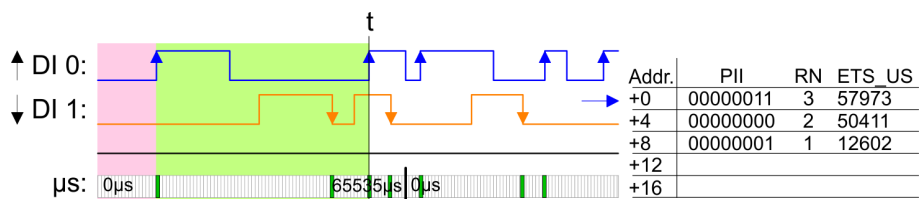

4. ETS entry

Released by an edge 1-0 from DI 1 the 4. ETS entry is registered starting from address +0 and already existing ETS entries are shifted 4 byte each.

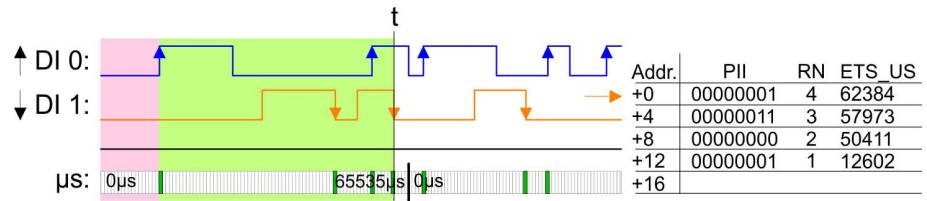

5. ETS entry

Released by an edge 0-1 from DI 0 the 5. ETS entry is registered starting from address +0 and already existing ETS entries are shifted 4 byte each. The maximum number of ETS entries is reached.

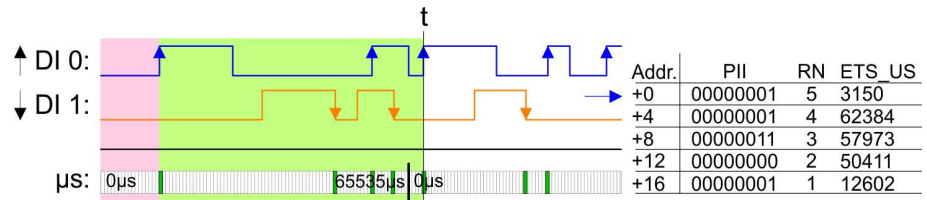

6. ETS entry

Released by an edge 1-0 from DI 1 the 6. ETS entry is registered starting from address +0 and already existing ETS entries are shifted 4 byte each. Thereby the 1. ETS entry is deleted and is not available any longer.

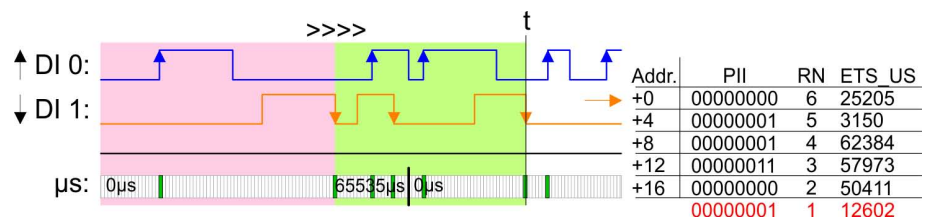

7. ETS entry

Released by an edge 0-1 from DI 0 the 7. ETS entry is registered starting from address +0 and already existing ETS entries are shifted 4 byte each. Thereby the 2. ETS entry is deleted and is not available any longer.

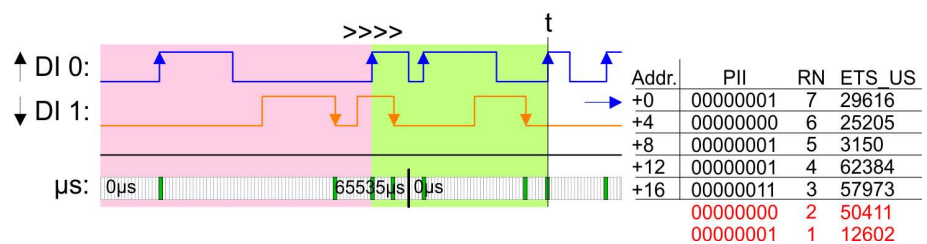

8. ETS entry

Released by an edge 0-1 from DI 0 the 8. ETS entry is registered starting from address +0 and already existing ETS entries are shifted 4 byte each. Thereby the 3. ETS entry is deleted and is not available any longer.

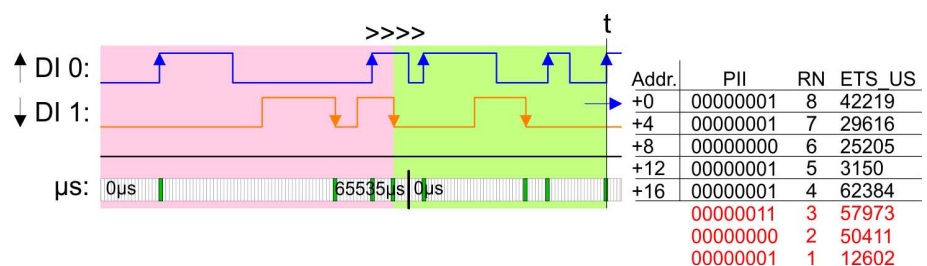



Please consider the ETS modules can only effectively be used together with head modules, which have an integrated μ s ticker. The Ethernet coupler with ModbusTCP 053-1MT00 for example does not have an μ s ticker.

3.9.3 Diagnostic data

So this module does not support interrupt functions, the diagnostic data serve the information about this module.

DS - Record set for access via CPU, PROFIBUS and PROFINET. The access happens by DS 01h. Additionally the first 4 bytes may be accessed by DS 00h.

IX - Index for access via CANopen. The access happens by IX 2F01h. Additionally the first 4 bytes may be accessed by IX 2F00h.

SX - Subindex (5005h) for access via EtherCAT.

More can be found in the according manual of your bus coupler.

Name	Bytes	Function	Default	DS	IX	SX
ERR_A	1	reserved	00h	01h	2F01h	02h
MODTYP	1	Module information	1Fh			03h
ERR_C	1	reserved	00h			04h
ERR_D	1	reserved	00h			05h
CHTYP	1	Channel type	70h			06h
NUMBIT	1	Number of diagnostics bits per channel	00h			07h
NUMCH	1	Number channels of the module	04h			08h
CHERR	1	reserved	00h			09h
CH0ERR... CH7ERR	8	reserved	00h			0Ah ... 11h
DIAG_US	4	μ s ticker (32bit)	00h			13h

MODTYP Modul information

Byte	Bit 7 ... 0
0	Bit 3 ... 0: Module class 1111b Digital module Bit 4: Channel information present Bit 7 ... 5: reserved

021-1BF00 - DI 8xDC 24V

CHTYP Channel type

Byte	Bit 7 ... 0
0	Bit 6 ... 0: Channel type 70h: Digital input Bit 7: 0 (fix)

NUMBIT Diagnostic bits

Byte	Bit 7 ... 0
0	Number of diagnostics bits of the module per channel (here 00h)

NUMCH channels

Byte	Bit 7 ... 0
0	Number of channels of the module (here 04h)

DIAG_US μ s ticker

Byte	Bit 7 ... 0
0 ... 3	Value of the μ s ticker at the moment of the diagnostic data generation

**ERR_A/C/D CHERR,
CHxERR reserved**

Byte	Bit 7 ... 0
0	reserved

3.10 021-1BF00 - DI 8xDC 24V**Properties**

The electronic module collects the binary control signals from the process level and transmits them isolated to the central bus system. It has 8 channels and their status is monitored via LEDs.

- 8 digital inputs, isolated to the backplane bus
- Suited for switches and approximate switches
- Status indication of the channels via LEDs also with de-activated electronic power supply

Structure

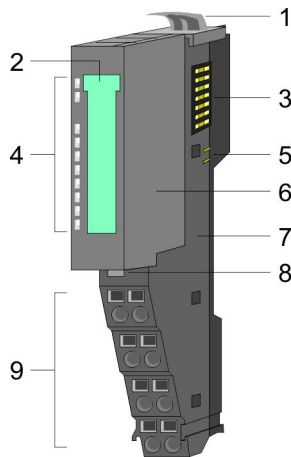

- 1 Locking lever terminal module
- 2 Labeling strip
- 3 Backplane bus
- 4 LED status indication
- 5 DC 24V power section supply
- 6 Electronic module
- 7 Terminal module
- 8 Locking lever electronic module
- 9 Terminal

Status indication

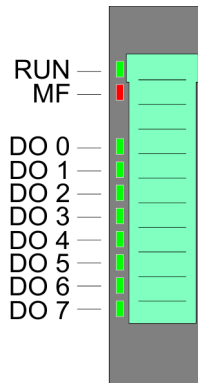

RUN	MF	DI x	Description
green	red	green	
■	■	■	
●	○	X	Bus communication is OK Module status is OK
●	●	X	Bus communication is OK Module status reports an error
○	●	X	Bus communication is not possible Module status reports an error
○	○	X	Error at bus power supply
X	B	X	Error in configuration ↪ <i>Chapter 2.7 'Trouble shooting - LEDs' on page 28</i>
●	○	●	Digital input has signal "1"
●	○	○	Digital input has signal "0"
on: ● off: ○ blinks with 2Hz: B not relevant: X			

Pin assignment

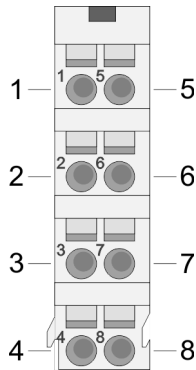

For wires with a cross section of 0.08mm² up to 1.5mm².

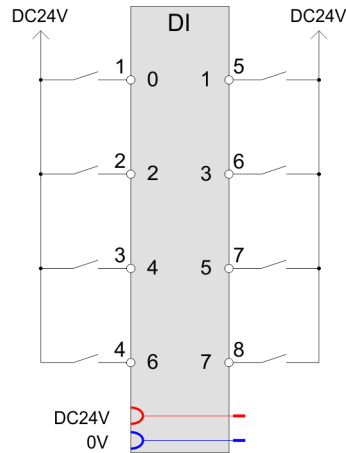

Pos.	Function	Type	Description
1	DI 0	I	Digital input DI 0
2	DI 2	I	Digital input DI 2
3	DI 4	I	Digital input DI 4
4	DI 6	I	Digital input DI 6
5	DI 1	I	Digital input DI 1
6	DI 3	I	Digital input DI 3
7	DI 5	I	Digital input DI 5
8	DI 7	I	Digital input DI 7

I: Input

Input area

At CPU, PROFIBUS and PROFINET the input area is embedded to the corresponding address area.

IX - Index for access via CANopen

SX - Subindex (6000h + EtherCAT-Slot) for access via EtherCAT

More can be found in the according manual of your bus coupler.

Addr.	Name	Bytes	Function	IX	SX
+0	PII	1	State of the inputs	6000h	
			Bit 0: DI 0		01h
			Bit 1: DI 1		02h
			Bit 2: DI 2		03h
			Bit 3: DI 3		04h
			Bit 4: DI 4		05h
			Bit 5: DI 5		06h

Addr.	Name	Bytes	Function	IX	SX
			Bit 6: DI 6		07h
			Bit 7: DI 7		08h

Output area No byte of the output area is used by the module.

3.10.1 Technical data

Order no.	021-1BF00
Type	SM 021
Module ID	0005 9FC1
Current consumption/power loss	
Current consumption from backplane bus	60 mA
Power loss	0.9 W
Technical data digital inputs	
Number of inputs	8
Cable length, shielded	1000 m
Cable length, unshielded	600 m
Rated load voltage	-
Current consumption from load voltage L+ (without load)	-
Rated value	DC 20.4...28.8 V
Input voltage for signal "0"	DC 0...5 V
Input voltage for signal "1"	DC 15...28.8 V
Input voltage hysteresis	-
Frequency range	-
Input resistance	-
Input current for signal "1"	3 mA
Connection of Two-Wire-BEROs possible	✓
Max. permissible BERO quiescent current	0.5 mA
Input delay of "0" to "1"	3 ms
Input delay of "1" to "0"	3 ms
Number of simultaneously utilizable inputs horizontal configuration	8
Number of simultaneously utilizable inputs vertical configuration	8
Input characteristic curve	IEC 61131-2, type 1
Initial data size	8 Bit

Order no.	021-1BF00
Status information, alarms, diagnostics	
Status display	green LED per channel
Interrupts	no
Process alarm	no
Diagnostic interrupt	no
Diagnostic functions	no
Diagnostics information read-out	none
Module state	green LED
Module error display	red LED
Channel error display	none
Isolation	
Between channels	-
Between channels of groups to	-
Between channels and backplane bus	✓
Insulation tested with	DC 500 V
Safety	
Safety protocol	-
Safety requirements	-
Secure user address	-
Watchdog	-
Two channels	-
Test pulse outputs	-
Datasizes	
Input bytes	1
Output bytes	0
Parameter bytes	0
Diagnostic bytes	0
Housing	
Material	PPE / PPE GF10
Mounting	Profile rail 35 mm
Mechanical data	
Dimensions (WxHxD)	12.9 mm x 109 mm x 76.5 mm
Weight	60 g
Environmental conditions	
Operating temperature	0 °C to 60 °C
Storage temperature	-25 °C to 70 °C

Order no.	021-1BF00
Certifications	
UL certification	yes

3.11 021-1BF01 - DI 8xDC 24V 0.5ms

Properties

The electronic module collects the binary control signals from the process level and transmits them isolated to the central bus system. It has 8 channels and their status is monitored via LEDs.

- 8 digital inputs, isolated to the backplane bus
- Suited for switches and approximate switches
- Status indication of the channels via LEDs also with de-activated electronic power supply

Structure

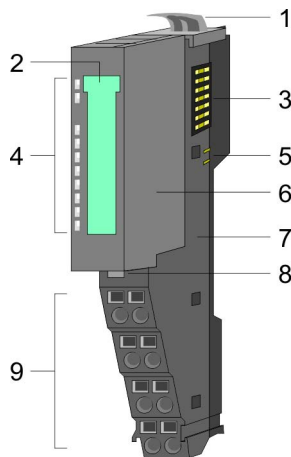

- 1 Locking lever terminal module
- 2 Labeling strip
- 3 Backplane bus
- 4 LED status indication
- 5 DC 24V power section supply
- 6 Electronic module
- 7 Terminal module
- 8 Locking lever electronic module
- 9 Terminal

Status indication

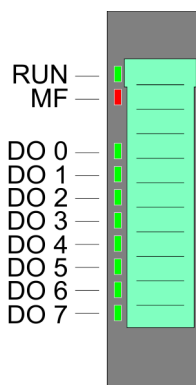

RUN	MF	DI x	Description
green	red	green	
■	■	■	
●	○	X	Bus communication is OK Module status is OK
●	●	X	Bus communication is OK Module status reports an error
○	●	X	Bus communication is not possible Module status reports an error
○	○	X	Error at bus power supply
X	B	X	Error in configuration ↪ Chapter 2.7 'Trouble shooting - LEDs' on page 28
●	○	●	Digital input has signal "1"

RUN	MF	DI x	Description
●	○	○	Digital input has signal "0"
on: ● off: ○ blinks with 2Hz: B not relevant: X			

Pin assignment

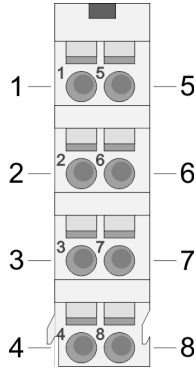

For wires with a cross section of 0.08mm² up to 1.5mm².

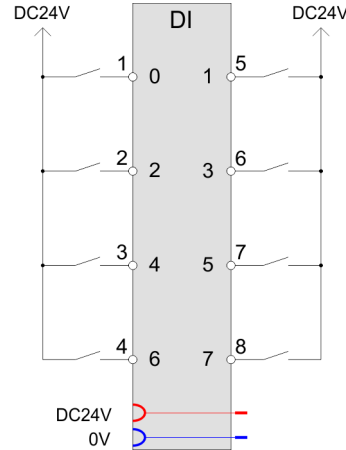

Pos.	Function	Type	Description
1	DI 0	I	Digital input DI 0
2	DI 2	I	Digital input DI 2
3	DI 4	I	Digital input DI 4
4	DI 6	I	Digital input DI 6
5	DI 1	I	Digital input DI 1
6	DI 3	I	Digital input DI 3
7	DI 5	I	Digital input DI 5
8	DI 7	I	Digital input DI 7

I: Input

Input area

At CPU, PROFIBUS and PROFINET the input area is embedded to the corresponding address area.

IX - Index for access via CANopen

SX - Subindex (6000h + EtherCAT-Slot) for access via EtherCAT

More can be found in the according manual of your bus coupler.

Addr.	Name	Bytes	Function	IX	SX
+0	PII	1	State of the inputs	6000h	
			Bit 0: DI 0		01h
			Bit 1: DI 1		02h
			Bit 2: DI 2		03h

Addr.	Name	Bytes	Function	IX	SX
			Bit 3: DI 3		04h
			Bit 4: DI 4		05h
			Bit 5: DI 5		06h
			Bit 6: DI 6		07h
			Bit 7: DI 7		08h

Output area

No byte of the output area is used by the module.

3.11.1 Technical data

Order no.	021-1BF01
Type	SM 021
Module ID	0013 9FC1
Current consumption/power loss	
Current consumption from backplane bus	60 mA
Power loss	0.9 W
Technical data digital inputs	
Number of inputs	8
Cable length, shielded	1000 m
Cable length, unshielded	600 m
Rated load voltage	-
Current consumption from load voltage L+ (without load)	-
Rated value	DC 20.4...28.8 V
Input voltage for signal "0"	DC 0...5 V
Input voltage for signal "1"	DC 15...28.8 V
Input voltage hysteresis	-
Frequency range	-
Input resistance	-
Input current for signal "1"	3 mA
Connection of Two-Wire-BEROs possible	✓
Max. permissible BERO quiescent current	0.5 mA
Input delay of "0" to "1"	max. 500 µs
Input delay of "1" to "0"	max. 500 µs
Number of simultaneously utilizable inputs horizontal configuration	8

Order no.	021-1BF01
Number of simultaneously utilizable inputs vertical configuration	8
Input characteristic curve	IEC 61131-2, type 1
Initial data size	8 Bit
Status information, alarms, diagnostics	
Status display	green LED per channel
Interrupts	no
Process alarm	no
Diagnostic interrupt	no
Diagnostic functions	no
Diagnostics information read-out	none
Module state	green LED
Module error display	red LED
Channel error display	none
Isolation	
Between channels	-
Between channels of groups to	-
Between channels and backplane bus	✓
Insulation tested with	DC 500 V
Safety	
Safety protocol	-
Safety requirements	-
Secure user address	-
Watchdog	-
Two channels	-
Test pulse outputs	-
Datasizes	
Input bytes	1
Output bytes	0
Parameter bytes	0
Diagnostic bytes	0
Housing	
Material	PPE / PPE GF10
Mounting	Profile rail 35 mm
Mechanical data	
Dimensions (WxHxD)	12.9 mm x 109 mm x 76.5 mm

Order no.	021-1BF01
Weight	60 g
Environmental conditions	
Operating temperature	0 °C to 60 °C
Storage temperature	-25 °C to 70 °C
Certifications	
UL certification	in preparation

3.12 021-1BF50 - DI 8xDC 24V NPN

Properties

The electronic module collects the binary control signals from the process level and transmits them isolated to the central bus system. It has 8 channels and their status is monitored via LEDs. An input becomes active as soon as it is connected to ground.

- 8 digital inputs (N switching), isolated to the backplane bus
- Suited for switches and approximate switches
- Status indication of the channels via LEDs also with de-activated electronic power supply

Structure

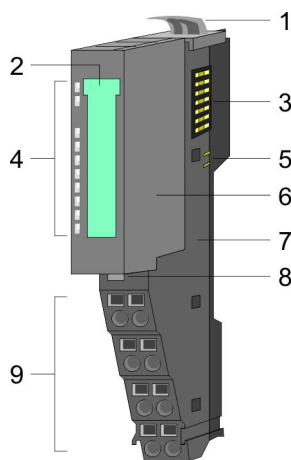

- 1 Locking lever terminal module
- 2 Labeling strip
- 3 Backplane bus
- 4 LED status indication
- 5 DC 24V power section supply
- 6 Electronic module
- 7 Terminal module
- 8 Locking lever electronic module
- 9 Terminal

Status indication

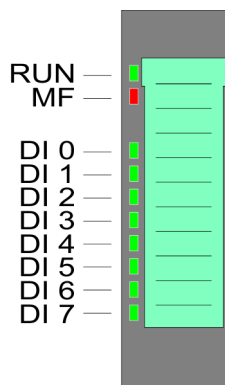

RUN	MF	DI x	Description
green	red	green	
■	■	■	
●	○	X	Bus communication is OK Module status is OK
●	●	X	Bus communication is OK Module status reports an error
○	●	X	Bus communication is not possible Module status reports an error

RUN	MF	DI x	Description
○	○	X	Error at bus power supply
X	B	X	Error in configuration ↪ <i>Chapter 2.7 'Trouble shooting - LEDs' on page 28</i>
●	○	●	Digital input has signal "1"
●	○	○	Digital input has signal "0"

on: ● | off: ○ | blinks with 2Hz: B | not relevant: X

Pin assignment

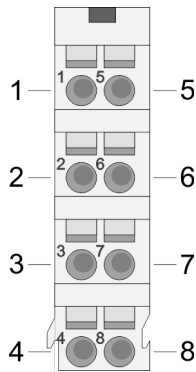

For wires with a cross section of 0.08mm² up to 1.5mm².

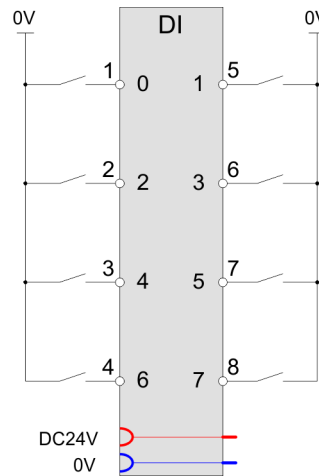

Pos.	Function	Type	Description
1	DI 0	I	Digital input DI 0
2	DI 2	I	Digital input DI 2
3	DI 4	I	Digital input DI 4
4	DI 6	I	Digital input DI 6
5	DI 1	I	Digital input DI 1
6	DI 3	I	Digital input DI 3
7	DI 5	I	Digital input DI 5
8	DI 7	I	Digital input DI 7

I: Input

Input area

At CPU, PROFIBUS and PROFINET the input area is embedded to the corresponding address area.

IX - Index for access via CANopen

SX - Subindex (6000h + EtherCAT-Slot) for access via EtherCAT

More can be found in the according manual of your bus coupler.

Addr.	Name	Bytes	Function	IX	SX
+0	PII	1	State of the inputs	6000h	
			Bit 0: DI 0		01h
			Bit 1: DI 1		02h
			Bit 2: DI 2		03h
			Bit 3: Di 3		04h
			Bit 4: DI 4		05h
			Bit 5: DI 5		06h
			Bit 6: DI 6		07h
			Bit 7: DI 7		08h

Output area

No byte of the output area is used by the module.

3.12.1 Technical data

Order no.	021-1BF50
Type	SM 021
Module ID	0007 9FC1
Current consumption/power loss	
Current consumption from backplane bus	65 mA
Power loss	0.9 W
Technical data digital inputs	
Number of inputs	8
Cable length, shielded	1000 m
Cable length, unshielded	600 m
Rated load voltage	-
Current consumption from load voltage L+ (without load)	-
Rated value	DC 20.4...28.8 V
Input voltage for signal "0"	DC 15...28.8 V
Input voltage for signal "1"	DC 0...5 V
Input voltage hysteresis	-
Frequency range	-
Input resistance	-
Input current for signal "1"	3 mA
Connection of Two-Wire-BEROs possible	✓
Max. permissible BERO quiescent current	0.5 mA
Input delay of "0" to "1"	3 ms

Order no.	021-1BF50
Input delay of "1" to "0"	3 ms
Number of simultaneously utilizable inputs horizontal configuration	8
Number of simultaneously utilizable inputs vertical configuration	8
Input characteristic curve	-
Initial data size	8 Bit
Status information, alarms, diagnostics	
Status display	green LED per channel
Interrupts	no
Process alarm	no
Diagnostic interrupt	no
Diagnostic functions	no
Diagnostics information read-out	none
Module state	green LED
Module error display	red LED
Channel error display	none
Isolation	
Between channels	-
Between channels of groups to	-
Between channels and backplane bus	✓
Insulation tested with	DC 500 V
Safety	
Safety protocol	-
Safety requirements	-
Secure user address	-
Watchdog	-
Two channels	-
Test pulse outputs	-
Datasizes	
Input bytes	1
Output bytes	0
Parameter bytes	0
Diagnostic bytes	0
Housing	
Material	PPE / PPE GF10
Mounting	Profile rail 35 mm

Order no.	021-1BF50
Mechanical data	
Dimensions (WxHxD)	12.9 mm x 109 mm x 76.5 mm
Weight	60 g
Environmental conditions	
Operating temperature	0 °C to 60 °C
Storage temperature	-25 °C to 70 °C
Certifications	
UL certification	yes

3.13 021-1DF00 - DI 8xDC 24V Diagnosis

Properties

The electronic module with diagnosis collects the binary control signals from the process level and transmits them isolated to the central bus system. It has 8 digital input channels (with parameterizable input delay) and their status is monitored via LEDs.

- 8 digital inputs, isolated to the backplane bus
- Suited for switches and approximate switches
- Monitoring wire break
- Parameterizable input delay
- Diagnostics function
- Status indication of the channels via LEDs also with de-activated electronic power supply

Structure

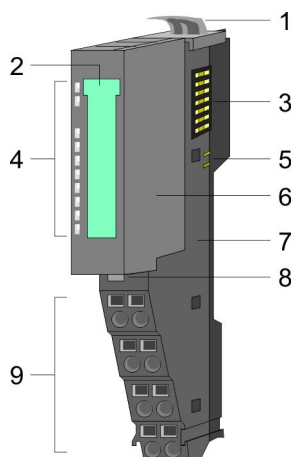

- 1 Locking lever terminal module
- 2 Labeling strip
- 3 Backplane bus
- 4 LED status indication
- 5 DC 24V power section supply
- 6 Electronic module
- 7 Terminal module
- 8 Locking lever electronic module
- 9 Terminal

Status indication

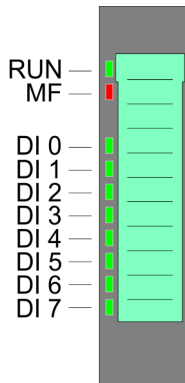

RUN	MF	DI x	Description
green ■	red ■	green ■	
●	○	X	Bus communication is OK Module status is OK
●	●	X	Bus communication is OK Module status reports an error
○	●	X	Bus communication is not possible Module status reports an error
○	○	X	Error at bus power supply
X	B	X	Error in configuration ↪ <i>Chapter 2.7 'Trouble shooting - LEDs' on page 28</i>
●	○	●	Digital input has signal "1"
●	○	○	Digital input has signal "0"
on: ● off: ○ blinks with 2Hz: B not relevant: X			

Pin assignment

For wires with a cross section of 0.08mm² up to 1.5mm².

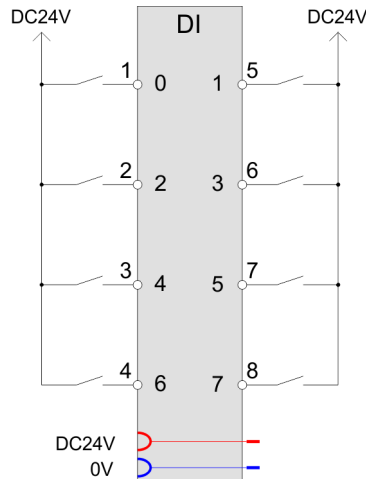
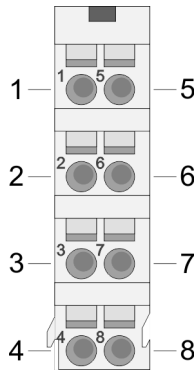

Pos.	Function	Type	Description
1	DI 0	I	Digital input DI 0
2	DI 2	I	Digital input DI 2
3	DI 4	I	Digital input DI 4
4	DI 6	I	Digital input DI 6
5	DI 1	I	Digital input DI 1
6	DI 3	I	Digital input DI 3
7	DI 5	I	Digital input DI 5
8	DI 7	I	Digital input DI 7

I: Input



To use wire break detection, there must be a minimum current of 0.5mA with signal state "0". This can be achieved by parallel connecting a resistor (22kΩ ... 47kΩ) on your switch.

Input area

At CPU, PROFIBUS and PROFINET the input area is embedded to the corresponding address area.

IX - Index for access via CANopen

SX - Subindex (6000h + EtherCAT-Slot) for access via EtherCAT

More can be found in the according manual of your bus coupler.

Adr.	Name	Bytes	Function	IX	SX
+0	PII	1	State of the inputs	6000h	
			Bit 0: DI 0		02h
			Bit 1: DI 1		03h

Adr.	Name	Bytes	Function	IX	SX
			Bit 2: DI 2		01h
			Bit 3: DI 3		04h
			Bit 4: DI 4		05h
			Bit 5: DI 5		06h
			Bit 6: DI 6		07h
			Bit 7: DI 7		08h

Output area No byte of the output area is used by the module.

3.13.1 Technical data

Order no.	021-1DF00
Type	SM 021
Module ID	0012 1F41
Current consumption/power loss	
Current consumption from backplane bus	60 mA
Power loss	1.1 W
Technical data digital inputs	
Number of inputs	8
Cable length, shielded	1000 m
Cable length, unshielded	600 m
Rated load voltage	-
Current consumption from load voltage L+ (without load)	-
Rated value	DC 20.4...28.8 V
Input voltage for signal "0"	DC 0...5 V
Input voltage for signal "1"	DC 10,8...28,8 V
Input voltage hysteresis	-
Frequency range	-
Input resistance	-
Input current for signal "1"	3 mA
Connection of Two-Wire-BEROs possible	✓
Max. permissible BERO quiescent current	1.5 mA
Input delay of "0" to "1"	parameterizable 100µs - 20ms
Input delay of "1" to "0"	parameterizable 100µs - 20ms
Number of simultaneously utilizable inputs horizontal configuration	8

Order no.	021-1DF00
Number of simultaneously utilizable inputs vertical configuration	8
Input characteristic curve	IEC 61131-2, type 3
Initial data size	8 Bit
Status information, alarms, diagnostics	
Status display	green LED per channel
Interrupts	yes
Process alarm	no
Diagnostic interrupt	yes, parameterizable
Diagnostic functions	yes
Diagnostics information read-out	possible
Module state	green LED
Module error display	red LED
Channel error display	none
Isolation	
Between channels	-
Between channels of groups to	-
Between channels and backplane bus	✓
Insulation tested with	DC 500 V
Safety	
Safety protocol	-
Safety requirements	-
Secure user address	-
Watchdog	-
Two channels	-
Test pulse outputs	-
Datasizes	
Input bytes	1
Output bytes	0
Parameter bytes	12
Diagnostic bytes	20
Housing	
Material	PPE / PPE GF10
Mounting	Profile rail 35 mm
Mechanical data	
Dimensions (WxHxD)	12.9 mm x 109 mm x 76.5 mm

Order no.	021-1DF00
Weight	60 g
Environmental conditions	
Operating temperature	0 °C to 60 °C
Storage temperature	-25 °C to 70 °C
Certifications	
UL certification	in preparation

3.13.2 Parameter data

DS - Record set for access via CPU, PROFIBUS and PROFINET

IX - Index for access via CANopen

SX - Subindex (3100h + EtherCAT-Slot) for access via EtherCAT

More can be found in the according manual of your bus coupler.

Name	Bytes	Function	Default	DS	IX	SX
DIAG_EN	1	Diagnostic interrupt *	00h	00h	3100h	01h
WIBRK_EN	1	Wire break recognition *	00h	00h	3101h	02h
C0_OptionNo	1	Filter time DI 0, DI 1	11h	80h	3102h	03h
C1_OptionNo	1	Filter time DI 2, DI 3	11h	81h	3103h	04h
C2_OptionNo	1	Filter time DI 4, DI 5	11h	82h	3104h	05h
C3_OptionNo	1	Filter time DI 6, DI 7	11h	83h	3105h	06h

*) This record set may only be transferred at STOP state.

DIAG_EN Diagnostic interrupt

Byte	Bit 7 ... 0
0	<ul style="list-style-type: none"> ■ Diagnostic interrupt: <ul style="list-style-type: none"> – 00h: disable – 40h: enable

■ Here you activate res. de-activate the diagnostic function.

WIBRK_EN Wire break recognition

Byte	Bit 7 ... 0
0	<ul style="list-style-type: none"> Bit 0: Wire break recognition DI 0 on "1" Bit 1: Wire break recognition DI 1 on "1" ... Bit 7: Wire break recognition DI 7 on "1"

■ Here you activate res. de-activate the Wire break recognition.

Cx_OptionNo Filter time

Byte	Function	Possible values
0	<ul style="list-style-type: none"> ■ Bit 3 ... 0: Filter time DI 0 ■ Bit 7 ... 4: Filter time DI 1 	1h: 100µs 2h: 400µs
0	<ul style="list-style-type: none"> ■ Bit 3 ... 0: Filter time DI 2 ■ Bit 7 ... 4: Filter time DI 3 	3h: 800µs 4h: 1.6ms
0	<ul style="list-style-type: none"> ■ Bit 3 ... 0: Filter time DI 4 ■ Bit 7 ... 4: Filter time DI 5 	5h: 3.2ms 6h: 10ms
0	<ul style="list-style-type: none"> ■ Bit 3 ... 0: Filter time DI 6 ■ Bit 7 ... 4: Filter time DI 7 	7h: 20ms Other values are not permissible!

- *Filter time* allows you to preset a input delay for the corresponding channel. With the help of filters you may e.g. filter signal peaks at a blurred input signal.

3.13.3 Diagnostic data

The following errors are listed in the diagnostics data:

- Error project engineering/parameterization
- Wire break (if parameterized)
- Internal communication error
- Internal diagnostics buffer overflow
- External power supply error

DS - Record set for access via CPU, PROFIBUS and PROFINET. The access happens by DS 01h. Additionally the first 4 bytes may be accessed by DS 00h.

IX - Index for access via CANopen. The access happens by IX 2F01h. Additionally the first 4 bytes may be accessed by IX 2F00h.

SX - Subindex (5005h) for access via EtherCAT.

More can be found in the according manual of your bus coupler.

Name	Bytes	Function	Default	DS	IX	SX
ERR_A	1	Diagnostic	00h	01h	2F01h	02h
MODTYP	1	Module information	1Fh			03h
ERR_C	1	reserved	00h			04h
ERR_D	1	Diagnostic	00h			05h
CHTYP	1	Channel type	70h			06h
NUMBIT	1	Number of diagnostics bits per channel	08h			07h
NUMCH	1	Number channels of the module	08h			08h
CHERR	1	Channel error	00h			09h

Name	Bytes	Function	Default	DS	IX	SX
CH0ERR	1	Channel specific error DI 1	00h			0Ah
CH1ERR	1	Channel specific error DI 2	00h			0Bh
...	
CH7ERR	1	Channel specific error DI 7	00h			11h
DIAG_US	4	µs ticker (32bit)	00h			13h

ERR_A Diagnostic

Byte	Bit 7 ... 0
0	<ul style="list-style-type: none"> ■ Bit 0: set at module failure ■ Bit 1: set at internal error ■ Bit 2: set at external error ■ Bit 3: set at channel error ■ Bit 4: set at external auxiliary supply missing ■ Bit 6, 5: reserved ■ Bit 7: set at error in parameterization

MODTYP Modul information

Byte	Bit 7 ... 0
0	<ul style="list-style-type: none"> ■ Bit 3 ... 0: Module class <ul style="list-style-type: none"> – 1111b: Digital module ■ Bit 4: Channel information present ■ Bit 7 ... 5: reserved

ERR_C reserved

Byte	Bit 7 ... 0
0	reserved

ERR_D Diagnostic

Byte	Bit 7 ... 0
0	<ul style="list-style-type: none"> ■ Bit 2 ... 0: reserved ■ Bit 3: set at internal diagnostics buffer overflow ■ Bit 4: set at internal communication error ■ Bit 7 ... 5: reserved

CHTYP Channel type

Byte	Bit 7 ... 0
0	<ul style="list-style-type: none"> ■ Bit 6 ... 0: Channel type <ul style="list-style-type: none"> – 70h: Digital input ■ Bit 7: reserved

NUMBIT Diagnostic bits

Byte	Bit 7 ... 0
0	Number of diagnostics bits of the module per channel (here 08h)

NUMCH Channels

Byte	Bit 7 ... 0
0	Number of channels of the module (here 08h)

CHERR DI x

Byte	Bit 7 ... 0
0	<ul style="list-style-type: none"> ■ Bit 0: Channel error DI 0 ■ Bit 1: Channel error DI 1 ■ ... ■ Bit 7: Channel error DI 7

CHxERR

Byte	Bit 7 ... 0
0	Channel-specific error: DI x: <ul style="list-style-type: none"> ■ Bit 0: set at error in project engineering/parameterization ■ Bit 3 ... 1: reserved ■ Bit 4: set at wire break ■ Bit 7 ... 5: reserved

DIAG_US μ s ticker

Byte	Bit 7 ... 0
0 ... 3	Value of the μ s ticker at the moment of the diagnostic

μ s ticker

In the SLIO module there is a 32 bit timer (μ s ticker). With PowerON the timer starts counting with 0. After $2^{32}-1\mu$ s the timer starts with 0 again.

4 Digital Output

4.1 022-1BB00 - DO 2xDC 24V 0.5A

Properties

The electronic module accepts binary control signals from the central bus system and transfers them to the process level via outputs. It has 2 channels and their status is monitored via LEDs.

- 2 digital outputs, isolated to the backplane bus
- Status indication of the channels via LEDs

Structure

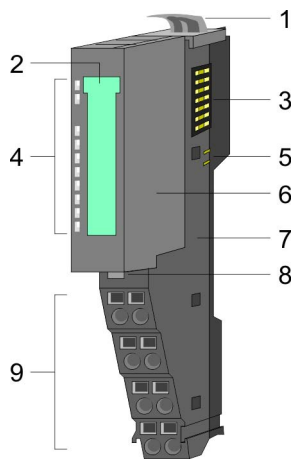

- 1 Locking lever terminal module
- 2 Labeling strip
- 3 Backplane bus
- 4 LED status indication
- 5 DC 24V power section supply
- 6 Electronic module
- 7 Terminal module
- 8 Locking lever electronic module
- 9 Terminal

Status indication

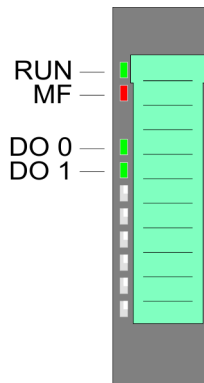

RUN	MF	DO x	Description
green	red	green	
■	■	■	
●	○	X	Bus communication is OK Module status is OK
●	●	X	Bus communication is OK Module status reports an error with over-load, short circuit or overheat
○	●	X	Bus communication is not possible Module status reports an error with over-load, short circuit or overheat
○	○	X	Error at bus power supply
X	B	X	Error in configuration ↪ <i>Chapter 2.7 'Trouble shooting - LEDs' on page 28</i>
●	○	●	Digital output has "1" signal
●	○	○	Digital output has "0" signal
on: ● off: ○ blinks with 2Hz: B not relevant: X			

Pin assignment

For wires with a cross section of 0.08mm² up to 1.5mm².

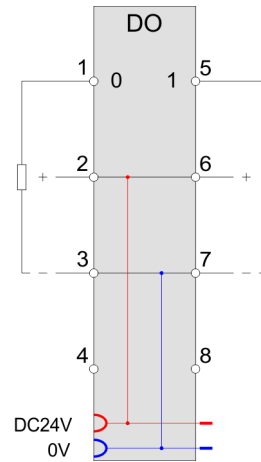
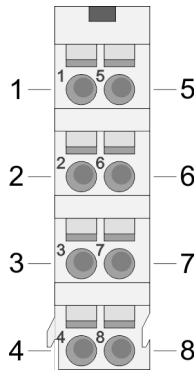

Pos.	Function	Type	Description
1	DO 0	O	Digital output DO 0
2	DC 24V	O	DC 24V
3	0V	O	GND for actuator
4	---	---	not connected
5	DO 1	O	Digital output DO 1
6	DC 24V	O	DC 24V
7	0V	O	GND for actuator
8	---	---	not connected

O: Output

Input area

No byte of the input area is used by the module.

Output area

At CPU, PROFIBUS and PROFINET the output area is embedded to the corresponding address area.

IX - Index for access via CANopen

SX - Subindex (7000h + EtherCAT-Slot) for access via EtherCAT

More can be found in the according manual of your bus coupler.

Addr.	Name	Bytes	Function	IX	SX
+0	PIQ	1	State of the outputs	5200h	
			Bit 0: DO 0		01h
			Bit 1: DO 1		02h
			Bit 7 ... 2: reserved		

4.1.1 Technical data

Order no.	022-1BB00
Type	SM 022
Module ID	0101 AF90
Current consumption/power loss	
Current consumption from backplane bus	55 mA
Power loss	0.4 W
Technical data digital outputs	
Number of outputs	2
Cable length, shielded	1000 m
Cable length, unshielded	600 m
Rated load voltage	DC 20.4...28.8 V
Current consumption from load voltage L+ (without load)	5 mA
Total current per group, horizontal configuration, 40°C	1 A
Total current per group, horizontal configuration, 60°C	1 A
Total current per group, vertical configuration	1 A
Output current at signal "1", rated value	0.5 A
Output delay of "0" to "1"	30 µs
Output delay of "1" to "0"	175 µs
Minimum load current	-
Lamp load	10 W
Parallel switching of outputs for redundant control of a load	not possible
Parallel switching of outputs for increased power	not possible
Actuation of digital input	✓
Switching frequency with resistive load	max. 1000 Hz
Switching frequency with inductive load	max. 0.5 Hz
Switching frequency on lamp load	max. 10 Hz
Internal limitation of inductive shut-off voltage	L+ (-45 V)
Short-circuit protection of output	yes, electronic
Trigger level	1 A
Number of operating cycle of relay outputs	-
Switching capacity of contacts	-
Output data size	2 Bit
Status information, alarms, diagnostics	

Order no.	022-1BB00
Status display	green LED per channel
Interrupts	no
Process alarm	no
Diagnostic interrupt	no
Diagnostic functions	no
Diagnostics information read-out	none
Supply voltage display	green LED
Group error display	red LED
Channel error display	none
Isolation	
Between channels	-
Between channels of groups to	-
Between channels and backplane bus	✓
Insulation tested with	DC 500 V
PWM data	
PWM channels	-
PWM time basis	-
Period length	-
Minimum pulse width	-
PtP communication	-
Safety	
Safety protocol	-
Safety requirements	-
Secure user address	-
Watchdog	-
Two channels	-
Test pulse length	-
Circuit monitoring	-
Datasizes	
Input bytes	0
Output bytes	1
Parameter bytes	0
Diagnostic bytes	0
Housing	
Material	PPE / PPE GF10
Mounting	Profile rail 35 mm

022-1BB20 - DO 2xDC 24V 2A

Order no.	022-1BB00
Mechanical data	
Dimensions (WxHxD)	12.9 mm x 109 mm x 76.5 mm
Weight	60 g
Environmental conditions	
Operating temperature	0 °C to 60 °C
Storage temperature	-25 °C to 70 °C
Certifications	
UL certification	yes

4.2 022-1BB20 - DO 2xDC 24V 2A

Properties

The electronic module accepts binary control signals from the central bus system and transfers them to the process level via outputs. It has 2 channels and their status is monitored via LEDs.

- 2 digital 2A outputs, isolated to the backplane bus
- Status indication of the channels via LEDs

Structure

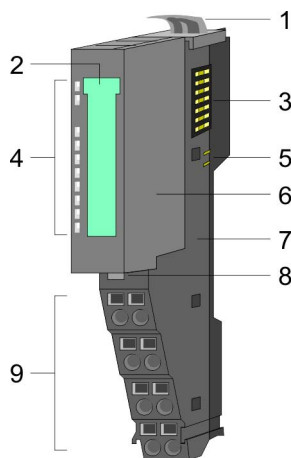

- 1 Locking lever terminal module
- 2 Labeling strip
- 3 Backplane bus
- 4 LED status indication
- 5 DC 24V power section supply
- 6 Electronic module
- 7 Terminal module
- 8 Locking lever electronic module
- 9 Terminal

Status indication

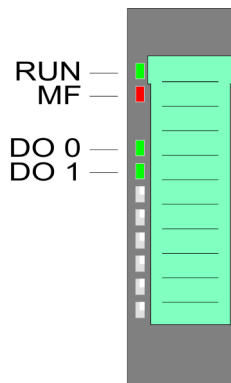

RUN	MF	DO x	Description
green	red	green	
■	■	■	
●	○	X	Bus communication is OK Module status is OK
●	●	X	Bus communication is OK Module status reports an error with over-load, short circuit or overheat

RUN	MF	DO x	Description
○	●	X	Bus communication is not possible Module status reports an error with over-load, short circuit or overheat
○	○	X	Error at bus power supply
X	B	X	Error in configuration ↪ <i>Chapter 2.7 'Trouble shooting - LEDs' on page 28</i>
●	○	●	Digital output has "1" signal
●	○	○	Digital output has "0" signal

on: ● | off: ○ | blinks with 2Hz: B | not relevant: X

Pin assignment

For wires with a cross section of 0.08mm² up to 1.5mm².

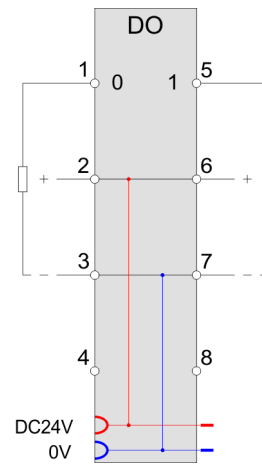
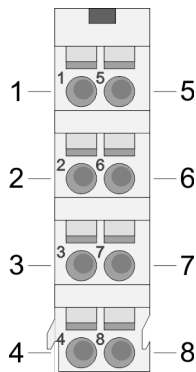

Pos.	Function	Type	Description
1	DO 0	O	Digital output DO 0
2	DC 24V	O	DC 24V
3	0V	O	GND for actuator
4	---	---	not connected
5	DO 1	O	Digital output DO 1
6	DC 24V	O	DC 24V
7	0V	O	GND for actuator
8	---	---	not connected

O: Output

Input area

No byte of the input area is used by the module.

Output area

At CPU, PROFIBUS and PROFINET the output area is embedded to the corresponding address area.

IX - Index for access via CANopen

SX - Subindex (7000h + EtherCAT-Slot) for access via EtherCAT

More can be found in the according manual of your bus coupler.

Addr.	Name	Bytes	Function	IX	SX
+0	PIQ	1	State of the outputs	5200h	
			Bit 0: DO 0		01h
			Bit 1: DO 1		02h
			Bit 7 ... 2: reserved		

4.2.1 Technical data

Order no.	022-1BB20
Type	SM 022
Module ID	0102 AF90
Current consumption/power loss	
Current consumption from backplane bus	60 mA
Power loss	0.55 W
Technical data digital outputs	
Number of outputs	2
Cable length, shielded	1000 m
Cable length, unshielded	600 m
Rated load voltage	DC 20.4...28.8 V
Current consumption from load voltage L+ (without load)	10 mA
Total current per group, horizontal configuration, 40°C	4 A
Total current per group, horizontal configuration, 60°C	4 A
Total current per group, vertical configuration	4 A
Output current at signal "1", rated value	2 A
Output delay of "0" to "1"	100 µs
Output delay of "1" to "0"	250 µs
Minimum load current	-
Lamp load	10 W
Parallel switching of outputs for redundant control of a load	not possible

Order no.	022-1BB20
Parallel switching of outputs for increased power	not possible
Actuation of digital input	✓
Switching frequency with resistive load	max. 1000 Hz
Switching frequency with inductive load	max. 0.5 Hz
Switching frequency on lamp load	max. 10 Hz
Internal limitation of inductive shut-off voltage	L+ (-52 V)
Short-circuit protection of output	yes, electronic
Trigger level	2.7 A
Number of operating cycle of relay outputs	-
Switching capacity of contacts	-
Output data size	2 Bit
Status information, alarms, diagnostics	
Status display	green LED per channel
Interrupts	no
Process alarm	no
Diagnostic interrupt	no
Diagnostic functions	no
Diagnostics information read-out	none
Supply voltage display	green LED
Group error display	red LED
Channel error display	none
Isolation	
Between channels	-
Between channels of groups to	-
Between channels and backplane bus	✓
Insulation tested with	DC 500 V
PWM data	
PWM channels	-
PWM time basis	-
Period length	-
Minimum pulse width	-
PtP communication	-
Safety	
Safety protocol	-
Safety requirements	-

022-1BB50 - DO 2xDC 24V 0.5A NPN

Order no.	022-1BB20
Secure user address	-
Watchdog	-
Two channels	-
Test pulse length	-
Circuit monitoring	-
Datasizes	
Input bytes	0
Output bytes	1
Parameter bytes	0
Diagnostic bytes	0
Housing	
Material	PPE / PPE GF10
Mounting	Profile rail 35 mm
Mechanical data	
Dimensions (WxHxD)	12.9 mm x 109 mm x 76.5 mm
Weight	60 g
Environmental conditions	
Operating temperature	0 °C to 60 °C
Storage temperature	-25 °C to 70 °C
Certifications	
UL certification	yes

4.3 022-1BB50 - DO 2xDC 24V 0.5A NPN

Properties

The electronic module accepts binary control signals from the central bus system and transfers them to the process level via outputs. It has 2 channels connected to the power supply, which operate as low-side switch and their status is monitored via LEDs. Low-side switches are suited to switch grounds. With a short circuit between switch line and ground the load is activated but the power supply is not influenced.

- 2 digital low-side outputs, isolated to the backplane bus
- Status indication of the channels via LEDs

Structure

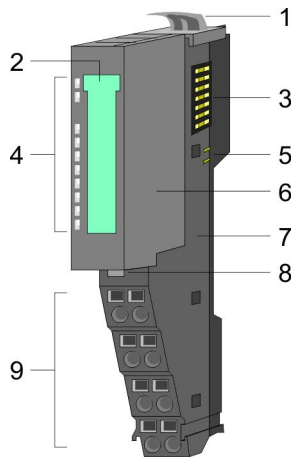

- 1 Locking lever terminal module
- 2 Labeling strip
- 3 Backplane bus
- 4 LED status indication
- 5 DC 24V power section supply
- 6 Electronic module
- 7 Terminal module
- 8 Locking lever electronic module
- 9 Terminal

Status indication

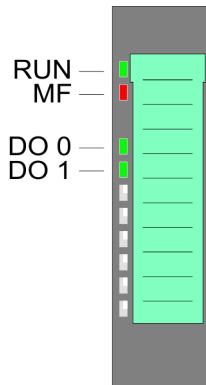

RUN	MF	DO x	Description
green	red	green	
■	■	■	
●	○	X	Bus communication is OK Module status is OK
●	●	X	Bus communication is OK Module status reports an error with over- load, short circuit or overheat
○	●	X	Bus communication is not possible Module status reports an error with over- load, short circuit or overheat
○	○	X	Error at bus power supply
X	B	X	Error in configuration ↪ <i>Chapter 2.7</i> <i>'Trouble shooting - LEDs' on page 28</i>
●	○	●	Digital output has "1" signal
●	○	○	Digital output has "0" signal
on: ● off: ○ blinks with 2Hz: B not relevant: X			

Pin assignment

For wires with a cross section of 0.08mm² up to 1.5mm².

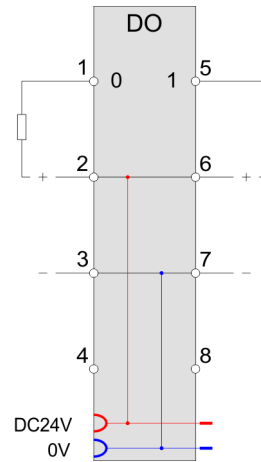
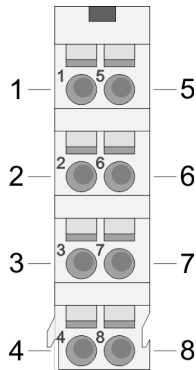

Pos.	Function	Type	Description
1	DO 0	O	Digital output DO 0
2	DC 24V	O	DC 24V for actuator
3	0V	O	GND
4	---	---	not connected
5	DO 1	O	Digital output DO 1
6	DC 24V	O	DC 24V for actuator
7	0V	O	GND
8	---	---	not connected

O: Output

Input area

No byte of the input area is used by the module.

Output area

At CPU, PROFIBUS and PROFINET the output area is embedded to the corresponding address area.

IX - Index for access via CANopen

SX - Subindex (7000h + EtherCAT-Slot) for access via EtherCAT

More can be found in the according manual of your bus coupler.

Addr.	Name	Bytes	Function	IX	SX
+0	PIQ	1	State of the outputs	5200h	
			Bit 0: DO 0		01h
			Bit 1: DO 1		02h
			Bit 7 ... 2: reserved		

4.3.1 Technical data

Order no.	022-1BB50
Type	SM 022
Module ID	0103 AF90
Current consumption/power loss	
Current consumption from backplane bus	60 mA
Power loss	0.4 W
Technical data digital outputs	
Number of outputs	2
Cable length, shielded	1000 m
Cable length, unshielded	600 m
Rated load voltage	DC 20.4...28.8 V
Current consumption from load voltage L+ (without load)	2.5 mA
Total current per group, horizontal configuration, 40°C	1 A
Total current per group, horizontal configuration, 60°C	1 A
Total current per group, vertical configuration	1 A
Output current at signal "1", rated value	0.5 A
Output delay of "0" to "1"	30 µs
Output delay of "1" to "0"	100 µs
Minimum load current	-
Lamp load	10 W
Parallel switching of outputs for redundant control of a load	not possible
Parallel switching of outputs for increased power	not possible
Actuation of digital input	✓
Switching frequency with resistive load	max. 1000 Hz
Switching frequency with inductive load	max. 0.5 Hz
Switching frequency on lamp load	max. 10 Hz
Internal limitation of inductive shut-off voltage	+45 V
Short-circuit protection of output	yes, electronic
Trigger level	1.7 A
Number of operating cycle of relay outputs	-
Switching capacity of contacts	-
Output data size	2 Bit
Status information, alarms, diagnostics	

Order no.	022-1BB50
Status display	green LED per channel
Interrupts	no
Process alarm	no
Diagnostic interrupt	no
Diagnostic functions	no
Diagnostics information read-out	none
Supply voltage display	green LED
Group error display	red LED
Channel error display	none
Isolation	
Between channels	-
Between channels of groups to	-
Between channels and backplane bus	✓
Insulation tested with	DC 500 V
PWM data	
PWM channels	-
PWM time basis	-
Period length	-
Minimum pulse width	-
PtP communication	-
Safety	
Safety protocol	-
Safety requirements	-
Secure user address	-
Watchdog	-
Two channels	-
Test pulse length	-
Circuit monitoring	-
Datasizes	
Input bytes	0
Output bytes	1
Parameter bytes	0
Diagnostic bytes	0
Housing	
Material	PPE / PPE GF10
Mounting	Profile rail 35 mm

Order no.	022-1BB50
Mechanical data	
Dimensions (WxHxD)	12.9 mm x 109 mm x 76.5 mm
Weight	60 g
Environmental conditions	
Operating temperature	0 °C to 60 °C
Storage temperature	-25 °C to 70 °C
Certifications	
UL certification	yes

4.4 022-1BB70 - DO 2xDC 24V 0.5A ETS

Properties

The electronic module accepts binary control signals from the central bus system and transfers them time-controlled by means of ETS functionality to the process level via outputs. It has 2 channels and their status is monitored via LEDs. With configured ETS functionality (ETS = edge time stamp) depending on the configuration 5 (20byte) respectively 15 (60byte), you may transfer the states for the outputs together with a time value of the μ s ticker as an ETS entry to the FIFO stack. The FIFO memory serves for space for max. 31 ETS entries.

- 2 digital outputs, isolated to the backplane bus
- FIFO stack for 5 respectively 15 ETS entries (each 4byte)
- Diagnostics function
- Controlling by process image respectively handling blocks
- Status indication of the channels via LEDs

Structure

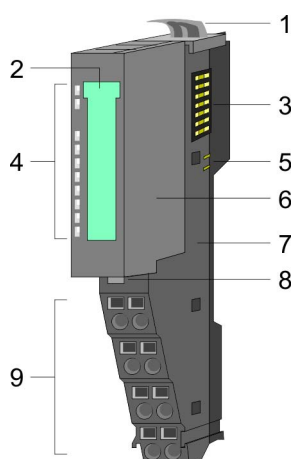

- 1 Locking lever terminal module
- 2 Labeling strip
- 3 Backplane bus
- 4 LED status indication
- 5 DC 24V power section supply
- 6 Electronic module
- 7 Terminal module
- 8 Locking lever electronic module
- 9 Terminal

Status indication

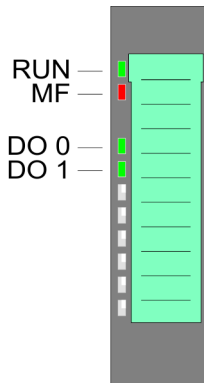

RUN	MF	DO x	Description
green	red	green	
●	○	X	Bus communication is OK Module status is OK
●	●	X	Bus communication is OK Module status reports an error with over- load, short circuit or overheat
○	●	X	Bus communication is not possible Module status reports an error with over- load, short circuit or overheat
○	○	X	Error at bus power supply
X	B	X	Error in configuration ↪ <i>Chapter 2.7</i> <i>'Trouble shooting - LEDs' on page 28</i>
●	○	●	Digital output has "1" signal
●	○	○	Digital output has "0" signal
on: ● off: ○ blinks with 2Hz: B not relevant: X			

Pin assignment

For wires with a cross section of 0.08mm² up to 1.5mm².

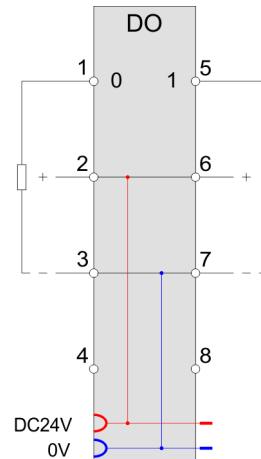
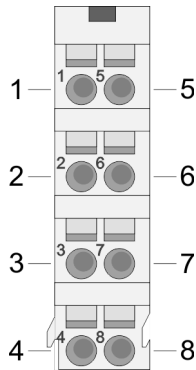

Pos.	Function	Type	Description
1	DO 0	O	Digital output DO 0
2	DC 24V	O	DC 24V
3	0V	O	GND for actuator
4	---	---	not connected
5	DO 1	O	Digital output DO 1
6	DC 24V	O	DC 24V
7	0V	O	GND for actuator
8	---	---	not connected

O: Output

In-/Output area

With configured ETS functionality (ETS=edge time stamp) a time value (ETS_US) together with the state of the outputs (PIQ) and a running number (RN) may be stored as ETS entry in the process image.

You may configure the following variants:

- 022-1BB70 DO 2xDC 24V (20):
FIFO with 20byte for 5 ETS entries
- 022-1BB70 DO 2xDC 24V (60):
FIFO with 60byte for 15 ETS entries



Please consider, with a full FIFO stack no further ETS entries may be accepted. To ensure that your ETS entries are kept, you should always check the state of the FIFO stack by STS_FIFO in the input area before.

Input area 4byte

The input range is used for status message. At CPU, PROFIBUS and PROFINET the input area is embedded to the corresponding address area.

IX - IX = Index for access via CANopen.

SX - Subindex (6000h + EtherCAT-Slot) for access via EtherCAT

More can be found in the according manual of your bus coupler.

Addr.	Name	Bytes	Function	IX	SX
+0	RN_LAST	1	Bit 5 ... 0: RN last FIFO entry Bit 6: 1 (fix) Bit 7: 0 (fix)	5440h	01h
+1	RN_NEXT	1	Bit 5 ... 0: RN next FIFO entry to be processed Bit 6: 1 (fix) Bit 7: 1 (fix)		02h
+2	STS_FIFO	1	State of the FIFO stack		03h
+3	NUM_ETS	1	Number of ETS entries in the FIFO stack		04h

RN_LAST

Bit 5 ... 0: Here the RN of the last ETS entry may be found, which was recognized as valid and written into the FIFO memory of the module.

Bit 6: 1 (fix) - serves for the identification in the process image

Bit 7: 0 (fix) - serves for the identification in the process image

RN_NEXT

Bit 5 ... 0: Here the RN of the ETS entry may be found, which will be executed next in the FIFO memory of the module. Please consider Bit 6 and 7 of RN_NEXT are always set.

Bit 6: 1 (fix) - serves for the identification in the process image

Bit 7: 1 (fix) - serves for the identification in the process image

STS_FIFO

The *State* informs about the state of the FIFO stack:

STS_FIFO	Description
00h/80h	Everything is OK. You will get this message directly after the storage in the FIFO memory of the module.
01h/81h	There is no following ETS entry in the FIFO. The RN does not correspond to the expected RN. Please check your RN in the output area.
02h/82h	There are no new ETS entries in the FIFO.
03h/83h	FIFO stack is full. There is no more place for further ETS entries.

If there are less ETS entries written as possible, additionally bit 6 of the last RN must be set. This is necessary; otherwise you have to overwrite the following entries with a "not valid" entry.

The module ignores entries after an entry with a set bit 6. If there is an ETS entry in the FIFO memory, whose bit 6 is set, STS_FIFO is always returned ored with 80h.

NUM_ETTS

Here always the current number of the ETS entries in the FIFO memory of the module may be found.

Structure of an ETS entry

Depending on the configuration up to 15 ETS entries may be written via the output area. Each ETS entry uses 4byte in the process image:

Addr.	Name	Bytes	Function	IX	SX
+0	PIQ	1	Output byte	5640h/s	01h
+1	RN	1	Running number		02h
+2	ETS_US	2	µs ticker		03h

PIQ

Here the state of the outputs for the corresponding time may be defined and the output channels may be enabled respectively disabled.

The output byte has the following bit allocation:

- Bit 3 ... 0: 0 (fix)
- Bit 4: Enable DO 1 (0: disable, 1: enable)
- Bit 5: Enable DO 0 (0: disable, 1: enable)
- Bit 6: State DO 1
- Bit 7: State DO 0

Time characteristics of an output

The simultaneous enabling and state change of an output should be avoided. Due to the different run times (see times A, B and C) up to the change of state this may affect unwanted switching effects.

The following figure shows the time characteristics of an output when using the enable bit.

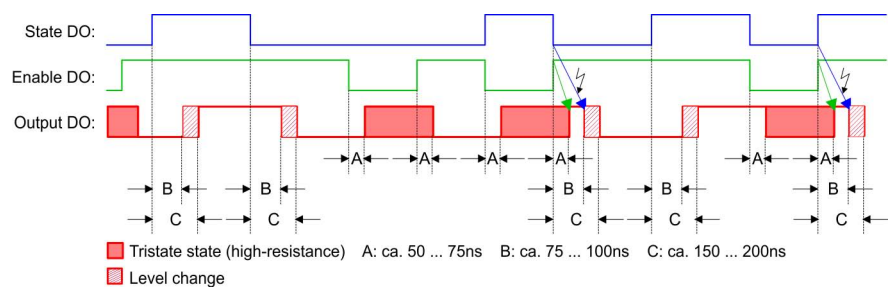

RN

RN (**R**unning **N**umber) is a continuous number 0 ... 63, which has to start with 1. With the RN the chronological order of the ETS entries may be defined. With each ETS entry RN is to be incremented, otherwise the ETS entry may not be recognized by the module.



If there are less ETS entries written as possible, additionally bit 6 of the last RN must be set. This is necessary; otherwise you have to overwrite the following entries with a "not valid" entry. The module ignores entries after an entry with a set bit 6.

ETS_US

In the SLIO module there is a 32 bit timer (μ s ticker). With PowerON the timer starts counting. After $2^{32}-1\mu$ s the timer starts with 0 again. For ETS_US of an ETS entry you have to define a time value from the low word of the μ s ticker (0...65535 μ s).

Here please enter a time value in μ s, to which the state of the outputs is to be taken. Range of values: 0 ... 65535

ETS functionality

The following picture shows how the ETS entries are to be preset in the output area, so that these can be stored in the FIFO memory.

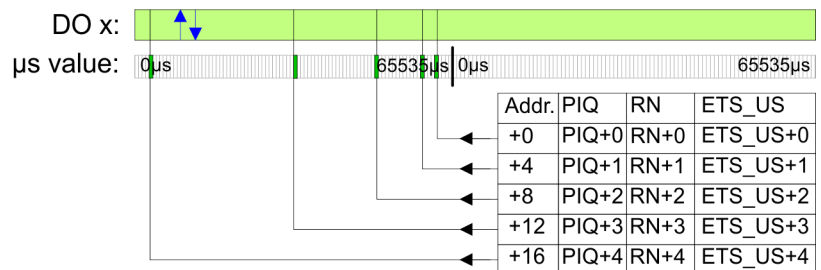

Output area 20byte respectively 60byte

At CPU, PROFIBUS and PROFINET the output area is embedded to the corresponding address area.

IX - Index for access via CANopen. With s = Subindex the corresponding ETS entry is addressed.

SX - Subindex (7000h + EtherCAT-Slot) for access via EtherCAT

More can be found in the according manual of your bus coupler.

Configured as 022-1BB70

DO 2xDC 24V (20)
20byte - 5 ETS entries

Addr.	PIQ	IX=5640h	SX	Addr.	RN	IX=5641h	SX	Addr.	ETS-US	IX=5642h	SX
+0	PIQ+0	s=1	01h	+1	RN+0	s=1	02h	+2	ETS_US+0	s=1	03h
+4	PIQ+1	s=2	04h	+5	RN+1	s=2	05h	+6	ETS_US+1	s=2	06h
+8	PIQ+2	s=3	07h	+9	RN+2	s=3	08h	+10	ETS_US+2	s=3	09h
+12	PIQ+3	s=4	0Ah	+13	RN+3	s=4	0Bh	+14	ETS_US+3	s=4	0Ch
+16	PIQ+4	s=5	0Dh	+17	RN+4	s=5	0Eh	+18	ETS_US+4	s=5	0Fh

**Configured as
022-1BB70**

DO 2xDC 24V (60)
60byte - 15 ETS entries

Addr.	PIQ	IX=5640h	SX	Addr.	RN	IX=5641h	SX	Addr.	ETS-US	IX=5642h	SX
+0	PIQ+0	s=1	01h	+1	RN+0	s=1	02h	+2	ETS_US+0	s=1	03h
+4	PIQ+1	s=2	04h	+5	RN+1	s=2	05h	+6	ETS_US+1	s=2	06h
+8	PIQ+2	s=3	07h	+9	RN+2	s=3	08h	+10	ETS_US+2	s=3	09h
+12	PIQ+3	s=4	0Ah	+13	RN+3	s=4	0Bh	+14	ETS_US+3	s=4	0Ch
+16	PIQ+4	s=5	0Dh	+17	RN+4	s=5	0Eh	+18	ETS_US+4	s=5	0Fh
+20	PIQ+5	s=6	10h	+21	RN+5	s=6	11h	+22	ETS_US+5	s=6	12h
+24	PIQ+6	s=7	13h	+25	RN+6	s=7	14h	+26	ETS_US+6	s=7	15h
+28	PIQ+7	s=8	16h	+29	RN+7	s=8	17h	+30	ETS_US+7	s=8	18h
+32	PIQ+8	s=9	19h	+33	RN+8	s=9	1Ah	+34	ETS_US+8	s=9	1Bh
+36	PIQ+9	s=10	1Ch	+37	RN+9	s=10	1Dh	+38	ETS_US+9	s=10	1Eh
+40	PIQ+10	s=11	1Fh	+41	RN+10	s=11	20h	+42	ETS_US+10	s=11	21h
+44	PIQ+11	s=12	22h	+45	RN+11	s=12	23h	+46	ETS_US+11	s=12	24h
+48	PIQ+12	s=13	25h	+49	RN+12	s=13	26h	+50	ETS_US+12	s=13	27h
+52	PIQ+13	s=14	28h	+53	RN+13	s=14	29h	+54	ETS_US+13	s=14	2Ah
+56	PIQ+14	s=15	2Bh	+57	RN+14	s=15	2Ch	+58	ETS_US+14	s=15	2Dh



The ETS module may only be accessed by the System SLIO CPU by means of SFC 15 or via the process image. Only the input data of the ETS module may be read by individual accesses.

4.4.1 Technical data

Order no.	022-1BB70
Type	SM 022
Module ID	0F41 57E1
Current consumption/power loss	
Current consumption from backplane bus	85 mA
Power loss	0.95 W
Technical data digital outputs	
Number of outputs	2
Cable length, shielded	1000 m
Cable length, unshielded	600 m

Order no.	022-1BB70
Rated load voltage	DC 20.4...28.8 V
Current consumption from load voltage L+ (without load)	15 mA
Total current per group, horizontal configuration, 40°C	1 A
Total current per group, horizontal configuration, 60°C	1 A
Total current per group, vertical configuration	1 A
Output current at signal "1", rated value	0.5 A
Output delay of "0" to "1"	max. 100 ns
Output delay of "1" to "0"	max. 100 ns
Minimum load current	-
Lamp load	10 W
Parallel switching of outputs for redundant control of a load	not possible
Parallel switching of outputs for increased power	not possible
Actuation of digital input	✓
Switching frequency with resistive load	max. 40 kHz
Switching frequency with inductive load	max. 40 kHz
Switching frequency on lamp load	max. 40 kHz
Internal limitation of inductive shut-off voltage	L+ (-52 V)
Short-circuit protection of output	yes, electronic, and only highside
Trigger level	2.5 A
Number of operating cycle of relay outputs	-
Switching capacity of contacts	-
Output data size	60 Byte
Status information, alarms, diagnostics	
Status display	green LED per channel
Interrupts	no
Process alarm	no
Diagnostic interrupt	no
Diagnostic functions	no
Diagnostics information read-out	possible
Supply voltage display	green LED
Group error display	red LED
Channel error display	none
Isolation	

Order no.	022-1BB70
Between channels	-
Between channels of groups to	-
Between channels and backplane bus	✓
Insulation tested with	DC 500 V
PWM data	
PWM channels	-
PWM time basis	-
Period length	-
Minimum pulse width	-
PtP communication	-
Safety	
Safety protocol	-
Safety requirements	-
Secure user address	-
Watchdog	-
Two channels	-
Test pulse length	-
Circuit monitoring	-
Datasizes	
Input bytes	4
Output bytes	20 / 60
Parameter bytes	6
Diagnostic bytes	20
Housing	
Material	PPE / PPE GF10
Mounting	Profile rail 35 mm
Mechanical data	
Dimensions (WxHxD)	12.9 mm x 109 mm x 76.5 mm
Weight	60 g
Environmental conditions	
Operating temperature	0 °C to 60 °C
Storage temperature	-25 °C to 70 °C
Certifications	
UL certification	yes

4.4.2 Parameter data

4.4.2.1 Parameters

The module has the following parameter data, which were fix set and may not be altered.

DS - Record set for access via CPU, PROFIBUS and PROFINET

IX - Index for access via CANopen

SX - Subindex (3100h + EtherCAT-Slot) for access via EtherCAT

More can be found in the according manual of your bus coupler.

Name	Bytes	Function	Default	DS	IX	SX
PII_L	1	Length process image input data ¹	04h (fix)	02h	3100h	01h
PIQ_L	1	Length process image output data ^{1, 2}	14h bzw. 3Ch (fix)	02h	3101h	02h

1) This record set may only be transferred at STOP state.

2) This parameter depends on the configured variant.

PII_L

Byte	Bit 7 ... 0
0	The length of the process image of the input data is fix set to 4byte.

PIQ_L

Byte	Bit 7 ... 0
0	The length of the process image of the output data is fix set to the configured variant (14h or 3Ch).

4.4.2.2 Example for the principle of operation

In the following it is demonstrated by an example, in which order the ETS entries are stored and processed.

With this example a module is configured, which uses 20byte for 5 ETS entries in the output area PIQ.

ETS values

With the following times of the µs ticker the following states of the outputs should be taken:

RN	ETS_US in µs	PIQ DO 0 (Bit 7)	PIQ DO 1 (Bit 6)	PIQ enable DO 0 (Bit 5)	PIQ enable DO 1 (Bit 4)
01h	6000	0	0	1	1
02h	12506	1	0	1	1

RN	ETS_US in μ s	PIQ DO 0 (Bit 7)	PIQ DO 1 (Bit 6)	PIQ enable DO 0 (Bit 5)	PIQ enable DO 1 (Bit 4)
03h	34518	1	1	1	1
04h	49526	0	0	1	1
05h	54529	0	1	1	1
06h	3500	1	1	1	1
07h	12443	1	0	1	1
08h	20185	0	0	1	1
09h	30140	1	0	1	1
0Ah	37330	0	0	1	1
0Bh	40000	0	0	0	0

Time diagram

From the table you get the following time diagram:

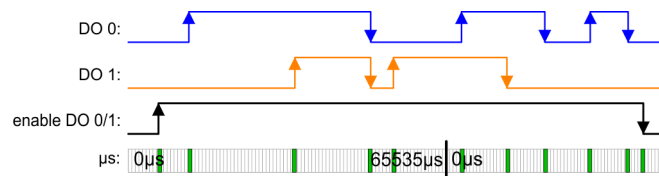

Writing 5 ETS entries

After writing the ETS entries into the process output image they are directly stored in the FIFO memory of the module.

The state of the outputs are shown in the diagram at the time "t".

In the PII you will find the status bytes.

Addr.	PIQ	RN	ETS_US	→	FIFO	PIQ	RN	ETS_US	PII
+0	00110000	01h	6000		1	00110000	01h	6000	RN_LAST: 45h RN_NEXT: C1h STS_FIFO: 00h NUM_ETS: 05h
+4	10110000	02h	12506		2	10110000	02h	12506	
+8	11110000	03h	34518		3	11110000	03h	34518	
+12	00110000	04h	49526		4	00110000	04h	49526	
+16	01110000	05h	54529		5	01110000	05h	54529	
					6	00000000	00h	0	
					7	00000000	00h	0	
					8	00000000	00h	0	
					9	00000000	00h	0	
					...	00000000	00h	0	
					31	00000000	00h	0	

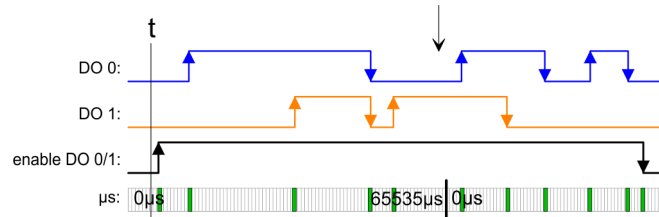

Executing ETS function for RN = 01h

So that the outputs can be controlled, they must be enabled before. In this example both outputs are enabled with the 1. RN.

The ETS entry (RN = 01h) is executed and deleted in the FIFO.

Addr.	PIQ	RN	ETS_US		FIFO	PIQ	RN	ETS_US	PII
+0	00110000	01h	6000	→	1	10110000	02h	12506	RN_LAST: 45h
+4	10110000	02h	12506		2	11110000	03h	34518	RN_NEXT: C2h
+8	11110000	03h	34518		3	00110000	04h	49526	STS_FIFO: 00h/02h
+12	00110000	04h	49526		4	01110000	05h	54529	NUM_ETS: 04h
+16	01110000	05h	54529		5	00000000	00h	0	
					6	00000000	00h	0	
					7	00000000	00h	0	
					8	00000000	00h	0	
					9	00000000	00h	0	
					...	00000000	00h	0	
					31	00000000	00h	0	

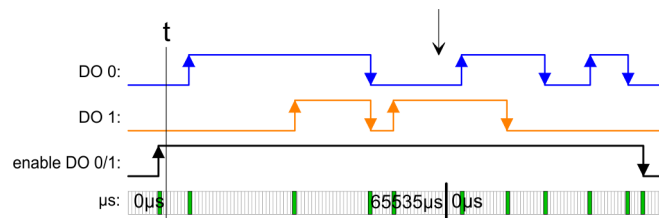

Executing ETS function for RN = 02h ... 04h

The states of RN = 02h ... RN 04h are successively issued and deleted in the FIFO.

Addr	PIQ	RN	ETS_US		FIFO	PIQ	RN	ETS_US	PII
+0	00110000	01h	6000	→	1	01110000	05h	54529	RN_LAST: 45h
+4	10110000	02h	12506		2	00000000	00h	0	RN_NEXT: C5h
+8	11110000	03h	34518		3	00000000	00h	0	STS_FIFO: 00h/02h
+12	00110000	04h	49526		4	00000000	00h	0	NUM_ETS: 01h
+16	01110000	05h	54529		5	00000000	00h	0	

6	00000000	00h	0
7	00000000	00h	0
8	00000000	00h	0
9	00000000	00h	0
...	00000000	00h	0
31	00000000	00h	0

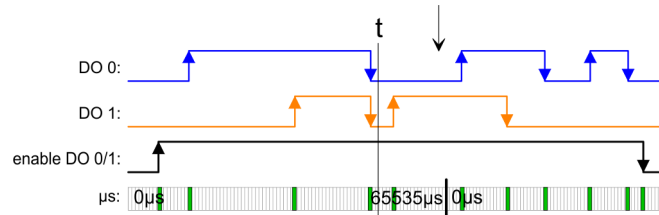

Writing 5 ETS entries

After writing the next 5 ETS entries into the process output image they are directly stored in the FIFO memory of the module.

Addr.	PIQ	RN	ETS_US	FIFO	PIQ	RN	ETS_US	PII
+0	11110000	06h	3500	→ 1	01110000	05h	54529	RN_LAST: 4Ah RN_NEXT: C5h STS_FIFO: 00h/02h NUM_ETS: 06h
+4	10110000	07h	12443	2	11110000	06h	3500	
+8	00110000	08h	20185	3	10110000	07h	12443	
+12	10110000	09h	30140	4	00110000	08h	20185	
+16	00110000	0Ah	37330	5	10110000	09h	30140	
				6	00110000	0Ah	37330	
				7	00000000	00h	0	
				8	00000000	00h	0	
				9	00000000	00h	0	
				...	00000000	00h	0	
				31	00000000	00h	0	

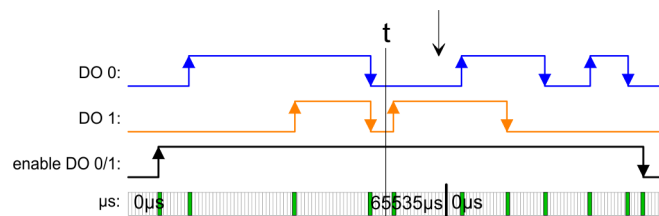

Executing ETS function for RN = 06h ... 08h

The states of RN = 06h ... RN 08h are successively issued and deleted in the FIFO.

Addr.	PIQ	RN	ETS_US		FIFO	PIQ	RN	ETS_US	PII
+0	11110000	06h	3500	→	1	10110000	09h	30140	RN_LAST: 4Ah
+4	10110000	07h	12443		2	00110000	0Ah	37330	RN_NEXT: C5h
+8	00110000	08h	20185		3	00000000	00h	0	STS_FIFO: 00h/02h
+12	10110000	09h	30140		4	00000000	00h	0	NUM_ETS: 02h
+16	00110000	0Ah	37330		5	00000000	00h	0	
				6	00000000	00h	0		
				7	00000000	00h	0		
				8	00000000	00h	0		
				9	00000000	00h	0		
				...	00000000	00h	0		
				31	00000000	00h	0		

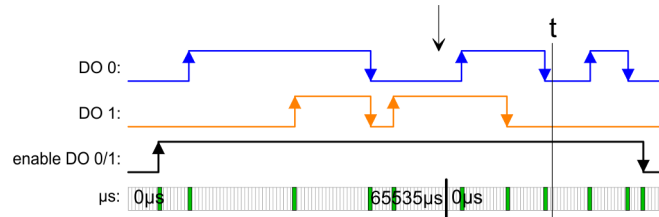

Writing last ETS entry

Since less than 5 ETS entries are written, bit 6 of RN of the last ETS entry must always be set. RN = 0Bh becomes 4Bh.

Addr.	PIQ	RN	ETS_US		FIFO	PIQ	RN	ETS_US	PII
+0	00000000	4Bh	40000	→	1	10110000	09h	30140	RN_LAST: 4Bh
+4	10110000	07h	12443		2	00110000	0Ah	37330	RN_NEXT: C9h
+8	00110000	08h	20185		3	00000000	4Bh	40000	STS_FIFO: 80h/82h
+12	10110000	09h	30140		4	00000000	00h	0	NUM_ETS: 03h
+16	00110000	0Ah	37330		5	00000000	00h	0	
				6	00000000	00h	0		
				7	00000000	00h	0		
				8	00000000	00h	0		
				9	00000000	00h	0		
				...	00000000	00h	0		
				31	00000000	00h	0		

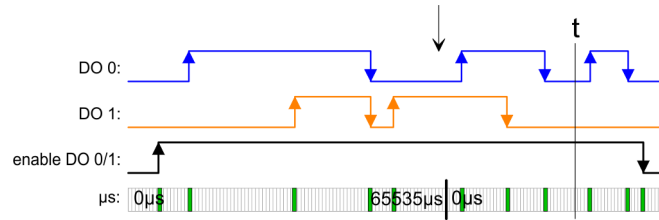

Executing ETS function for RN = 09h ... 4Bh

The states of RN = 09h ... RN 4Bh are successively issued and deleted in the FIFO.

Addr.	PIQ	RN	ETS_US		FIFO	PIQ	RN	ETS_US	PII
+0	00000000	4Bh	40000	→	1	00000000	00h	0	RN_LAST: 4Bh
+4	10110000	07h	12443		2	00000000	00h	0	RN_NEXT: CCh
+8	00110000	08h	20185		3	00000000	00h	0	STS_FIFO: 80h/ 82h
+12	10110000	09h	30140		4	00000000	00h	0	NUM_ETS: 00h
+16	00110000	0Ah	37330		5	00000000	00h	0	
					6	00000000	00h	0	
					7	00000000	00h	0	
					8	00000000	00h	0	
					9	00000000	00h	0	
					...	00000000	00h	0	
					31	00000000	00h	0	

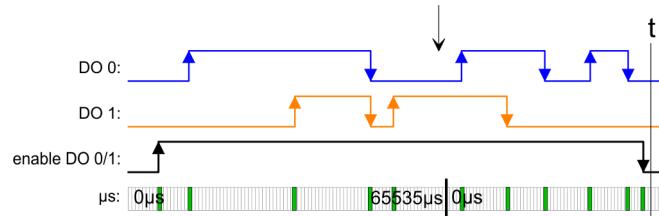

Please consider the ETS modules can only effectively be used together with head modules, which have an integrated µs ticker. The Ethernet coupler with ModbusTCP 053-1MT00 for example does not have an µs ticker.

4.4.3 Diagnostic data

This module does not support interrupt functions, the diagnostic data serve the information about this module.

DS - Record set for access via CPU, PROFIBUS and PROFINET. The access happens by DS 01h. Additionally the first 4 bytes may be accessed by DS 00h.

IX - Index for access via CANopen. The access happens by IX 2F01h. Additionally the first 4 bytes may be accessed by IX 2F00h.

SX - Subindex (5005h) for access via EtherCAT.

More can be found in the according manual of your bus coupler.

Name	Bytes	Function	Default	DS	IX	SX
ERR_A	1	reserved	00h	01h	2F01h	02h
MODTYP	1	Module information	1Fh			03h
ERR_C	1	reserved	00h			04h
ERR_D	1	reserved	00h			05h
CHTYP	1	Channel type	72h			06h
NUMBIT	1	Number of diagnostics bits per channel	00h			07h
NUMCH	1	Number channels of the module	02h			08h
CHERR	1	reserved	00h			09h
CH0ERR... CH7ERR	8	reserved	00h			0Ah ... 11h
DIAG_US	4	µs ticker (32bit)	00h			13h

MODTYP Modul information

Byte	Bit 7 ... 0
0	Bit 3 ... 0: Module class 1111b Digital module Bit 4: Channel information present Bit 7 ... 5: reserved

CHTYP Channel type

Byte	Bit 7 ... 0
0	Bit 6 ... 0: Channel type 72h: Digital output Bit 7: 0 (fix)

NUMBIT Diagnostic bits

Byte	Bit 7 ... 0
0	Number of diagnostics bits of the module per channel (here 00h)

NUMCH Number of channels

Byte	Bit 7 ... 0
0	Number of channels of the module (here 02h)

DIAG_US μ s ticker

Byte	Bit 7 ... 0
0 ... 3	Value of the μ s ticker at the moment of the diagnostic data generation

ERR_A/C/D CHERR, CHxERR reserved

Byte	Bit 7 ... 0
0	reserved

4.5 022-1BB90 - DO 2xDC 24V 0.5A PWM

Properties

The electronic has 2 output channels with PWM functionality (PWM = pulse width modulation). By presetting of time parameter a pulse sequence with according pulse/break ratio may be issued at the corresponding output channel.

- 2 PWM outputs, isolated to the backplane bus
- PWM outputs switchable between *push/pull* and *high side*
- Diagnostics function
- Status indication of the channels via LEDs
- PWM status
- Variable period duration and pulse duty ratio

Structure

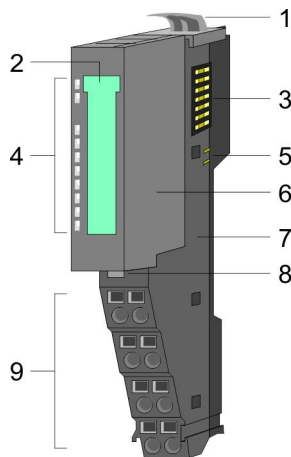

- 1 Locking lever terminal module
- 2 Labeling strip
- 3 Backplane bus
- 4 LED status indication
- 5 DC 24V power section supply
- 6 Electronic module
- 7 Terminal module
- 8 Locking lever electronic module
- 9 Terminal

Status indication

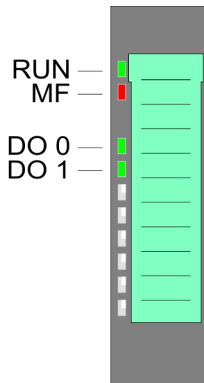

RUN	MF	DO x	Description
green	red	green	
●	○	X	Bus communication is OK Module status is OK
●	●	X	Bus communication is OK Module status reports an error with over- load, short circuit or overheat
○	●	X	Bus communication is not possible Module status reports an error with over- load, short circuit or overheat
○	○	X	Error at bus power supply
X	B	X	Error in configuration ↪ <i>Chapter 2.7</i> <i>'Trouble shooting - LEDs' on page 28</i>
●	○	●	PWM output has "1" signal
●	○	○	PWM output has "0" signal
on: ● off: ○ blinks with 2Hz: B not relevant: X			

Pin assignment

For wires with a cross section of 0.08mm² up to 1.5mm².

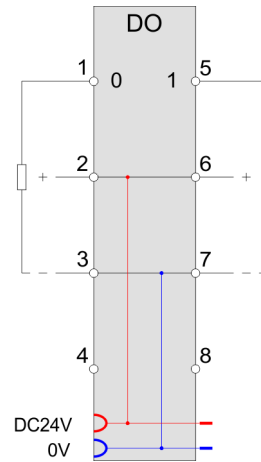
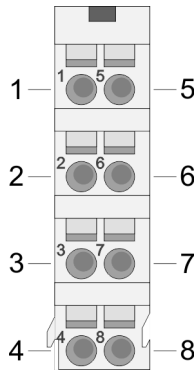

Pos.	Function	Type	Description
1	DO 0	O	PWM output DO 0
2	DC 24V	O	DC 24V
3	0V	O	GND for actuator
4	---	---	not connected
5	DO 1	O	PWM output DO 1
6	DC 24V	O	DC 24V
7	0V	O	GND for actuator
8	---	---	not connected

O: Output

Input area 4byte

At CPU, PROFIBUS and PROFINET the input respectively output area is embedded to the corresponding address area.

IX - Index for access via CANopen with s = subindex, depends on number of PWM modules

SX - Subindex (6000h + EtherCAT-Slot) for access via EtherCAT

More can be found in the according manual of your bus coupler.

Addr.	Name	Bytes	Function	IX	SX
+0	PWMSTS_I	2	PWM 0: Status	5420h/s	01h
+2	PWMSTS_II	2	PWM 1: Status	5420h/s+1	02h

Status PWM x

Bit	Name	Function
0	-	reserved
1	STS_PWM	Status PWM 0: PWM output stopped 1: PWM output activated
2	STS_OUTBV	Status output 0: Push/Pull output 1: High side output
3 ... 15	-	reserved

Output area 12byte

At CPU, PROFIBUS and PROFINET the output area is embedded to the corresponding address area.

IX - Index for access via CANopen with s = subindex, depends on number of PWM modules

SX - Subindex (7000h + EtherCAT-Slot) for access via EtherCAT

More can be found in the according manual of your bus coupler.

Addr.	Name	Bytes	Function	IX	SX
+0	PWMPD_I	4	PWM 0: Pulse duration	5620h/s	01h
+4	PWMPD_II	4	PWM 1: Pulse duration	5620h/s+1	02h
+8	PWMCTRL_I	2	PWM 0: Control word	5621h/s	03h
+10	PWMCTRL_II	2	PWM 1: Control word	5621h/s+1	04h

**PWMPD_I PWMPD_II
Pulse duration**

Here you have to define the pulse duty ratio for the configured *period duration*, by presetting the high level for the corresponding PWM channel. The pulse duration is to be preset as factor to the base 20.83ns.

Range of values: 48 ... 8388607 (1µs ... ca. 175ms)

**PWMCTRL_I
PWMCTRL_II Control word**

Here for the corresponding channel the PWM output behavior may be preset and the PWM output may be started respectively stopped.

Bit	Name	Function
0 ... 1	-	reserved
2	CTRL_OUTBV	PWM output behavior 0: Push/Pull output 1: High side output With <i>Push/Pull</i> operation it is active switched to high and low level. With <i>High side</i> operation it is only active switched to high level.
3 ... 7	-	reserved
8	CTRL_STRT	Edge 0-1 starts PWM output at channel x
9	CTRL_STP	Edge 0-1 stops PWM output at channel x
10 ... 15	-	reserved

4.5.1 Technical data

Order no.	022-1BB90
Type	SM 022
Module ID	0901 4880
Current consumption/power loss	
Current consumption from backplane bus	85 mA
Power loss	0.95 W
Technical data digital outputs	
Number of outputs	2
Cable length, shielded	1000 m
Cable length, unshielded	600 m
Rated load voltage	DC 20.4...28.8 V
Current consumption from load voltage L+ (without load)	15 mA
Total current per group, horizontal configuration, 40°C	1 A
Total current per group, horizontal configuration, 60°C	1 A
Total current per group, vertical configuration	1 A
Output current at signal "1", rated value	0.5 A
Output delay of "0" to "1"	max. 100 ns
Output delay of "1" to "0"	max. 100 ns
Minimum load current	-
Lamp load	10 W

Order no.	022-1BB90
Parallel switching of outputs for redundant control of a load	not possible
Parallel switching of outputs for increased power	not possible
Actuation of digital input	✓
Switching frequency with resistive load	max. 40 kHz
Switching frequency with inductive load	max. 40 kHz
Switching frequency on lamp load	max. 40 kHz
Internal limitation of inductive shut-off voltage	L+ (-52 V)
Short-circuit protection of output	yes, electronic, and only highside
Trigger level	2.5 A
Number of operating cycle of relay outputs	-
Switching capacity of contacts	-
Output data size	12 Byte
Status information, alarms, diagnostics	
Status display	green LED per channel
Interrupts	no
Process alarm	no
Diagnostic interrupt	no
Diagnostic functions	no
Diagnostics information read-out	possible
Supply voltage display	green LED
Group error display	red LED
Channel error display	none
Isolation	
Between channels	-
Between channels of groups to	-
Between channels and backplane bus	✓
Insulation tested with	DC 500 V
PWM data	
PWM channels	2
PWM time basis	20.83ns
Period length	1200...8388607 * time base
Minimum pulse width	1 µs
Output type	Push pull / highside
Safety	
Safety protocol	-

Order no.	022-1BB90
Safety requirements	-
Secure user address	-
Watchdog	-
Two channels	-
Test pulse length	-
Circuit monitoring	-
Datasizes	
Input bytes	4
Output bytes	12
Parameter bytes	12
Diagnostic bytes	20
Housing	
Material	PPE / PPE GF10
Mounting	Profile rail 35 mm
Mechanical data	
Dimensions (WxHxD)	12.9 mm x 109 mm x 76.5 mm
Weight	60 g
Environmental conditions	
Operating temperature	0 °C to 60 °C
Storage temperature	-25 °C to 70 °C
Certifications	
UL certification	yes

4.5.2 Parameter data

DS - Record set for access via CPU, PROFIBUS and PROFINET

IX - Index for access via CANopen

SX - Subindex (3100h + EtherCAT-Slot) for access via EtherCAT

More can be found in the according manual of your bus coupler.

Name	Bytes	Function	Default	DS	IX	SX
PWMPD_I	4	PWM 0: Period duration (Base time: 20.83ns)	1F40h	80h	3100h ... 3103	01h
PWMPD_II	4	PWM 1: Period duration (Base time: 20.83ns)	1F40h	81h	3104h ... 3107	02h

PWMPD_x Period duration

Byte	Bit 7 ... 0
0 ... 3	<p>PWM x Period duration</p> <p>Here you have to configure the whole time for <i>Pulse duration</i> and <i>Pulse break</i>. The time is to be preset as factor to the base 20.83ns.</p> <p>Values lower than 25µs are ignored. Is the <i>pulse duration</i> value greater than or equal the value of <i>period duration</i> the output is permanently set.</p> <p>Range of values: 1200 ... 8388607 (25µs ... ca. 175ms)</p>

Principle of operation

By presetting the *period duration* via parameterization and the *pulse duration* via the output area, the pulse duty ratio for the corresponding PWM output channel may be defined.

By changing the pulse duty ration e.g. a drive system, which is connected via PWM may be controlled by the user program.

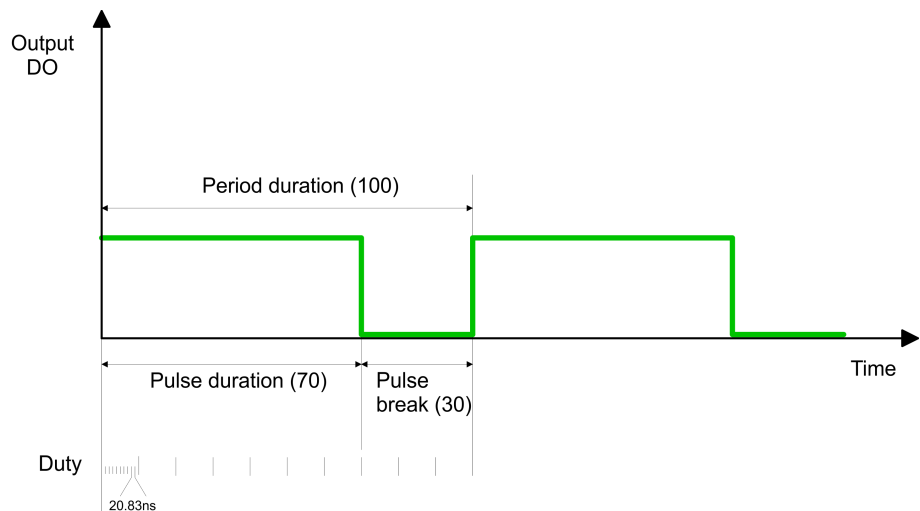

4.5.3 Diagnostic data

So this module does not support process interrupts, the diagnostics data serve for information about this module.

DS - Record set for access via CPU, PROFIBUS and PROFINET. The access happens by DS 01h. Additionally the first 4 bytes may be accessed by DS 00h.

IX - Index for access via CANopen. The access happens by IX 2F01h. Additionally the first 4 bytes may be accessed by IX 2F00h.

SX - Subindex (5005h) for access via EtherCAT.

More can be found in the according manual of your bus coupler.

Name	Bytes	Function	Default	DS	IX	SX
ERR_A	1	reserved	00h	01h	2F01h	02h
MODTYP	1	Module information	1Fh			03h
ERR_C	1	reserved	00h			04h
ERR_D	1	reserved	00h			05h
CHTYP	1	Channel type	72h			06h
NUMBIT	1	Number of diagnostics bits per channel	00h			07h
NUMCH	1	Number channels of the module	02h			08h
CHERR	1	reserved	00h			09h
CH0ERR... CH7ERR	8	reserved	00h			0Ah ... 11h
DIAG_US	4	µs ticker (32bit)	00h			13h

MODTYP Module information

Byte	Bit 7 ... 0
0	Bit 3 ... 0: Module class 1111b: Digital module Bit 4: Channel information present Bit 7 ... 5: reserved

CHTYP Channel type

Byte	Bit 7 ... 0
0	Bit 6 ... 0: Channel type 72h: Digital output Bit 7: reserved

NUMBIT Diagnostic bits

Byte	Bit 7 ... 0
0	Number of diagnostics bits of the module per channel (here 00h)

NUMCH Channels

Byte	Bit 7 ... 0
0	Number of channels of the module (here 02h)

DIAG_US µs ticker

Byte	Bit 7 ... 0
0 ... 3	Value of the µs ticker at the moment of the diagnostic data generation

**ERR_C/D CHERR,
CHxERR reserved**

Byte	Bit 7 ... 0
0	reserved

4.6 022-1BD00 - DO 4xDC 24V 0.5A

Properties

The electronic module accepts binary control signals from the central bus system and transfers them to the process level via outputs. It has 4 channels and their status is monitored via LEDs.

- 4 digital outputs, isolated to the backplane bus
- Status indication of the channels via LEDs

Structure

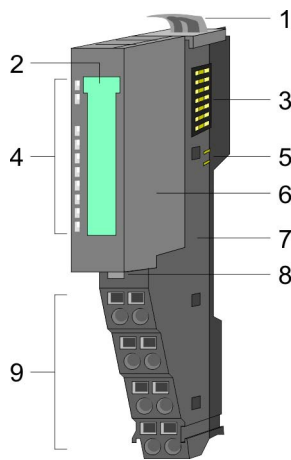

- 1 Locking lever terminal module
- 2 Labeling strip
- 3 Backplane bus
- 4 LED status indication
- 5 DC 24V power section supply
- 6 Electronic module
- 7 Terminal module
- 8 Locking lever electronic module
- 9 Terminal

Status indication

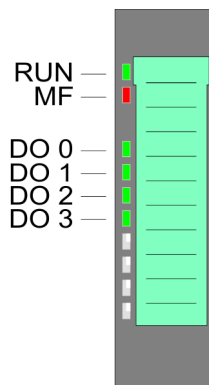

RUN	MF	DO x	Description
green	red	green	
■	■	■	
●	○	X	Bus communication is OK Module status is OK
●	●	X	Bus communication is OK Module status reports an error with over- load, short circuit or overheat
○	●	X	Bus communication is not possible Module status reports an error with over- load, short circuit or overheat
○	○	X	Error at bus power supply
X	B	X	Error in configuration ↪ <i>Chapter 2.7 'Trouble shooting - LEDs' on page 28</i>
●	○	●	Digital output has "1" signal
●	○	○	Digital output has "0" signal
on: ● off: ○ blinks with 2Hz: B not relevant: X			

Pin assignment

For wires with a cross section of 0.08mm² up to 1.5mm².

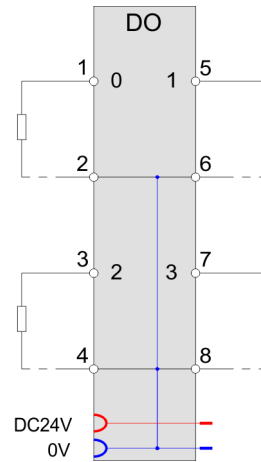
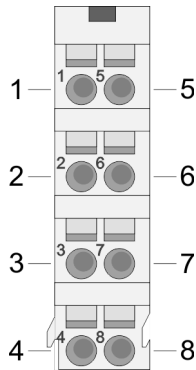

Pos.	Function	Type	Description
1	DO 0	O	Digital output DO 0
2	0V	O	GND for actuator DO 0
3	DO 2	O	Digital output DO 2
4	0V	O	GND for actuator DO 2
5	DO 1	O	Digital output DO 1
6	0V	O	GND for actuator DO 1
7	DO 3	O	Digital output DO 3
8	0V	O	GND for actuator DO 3

O: Output

Input area

No byte of the input area is used by the module.

Output area

At CPU, PROFIBUS and PROFINET the output area is embedded to the corresponding address area.

IX - Index for access via CANopen

SX - Subindex (7000h + EtherCAT-Slot) for access via EtherCAT

More can be found in the according manual of your bus coupler.

Addr.	Name	Bytes	Function	IX	SX
+0	PIQ	1	State of the outputs	5200h	
			Bit 0: DO 0		01h
			Bit 1: DO 1		02h
			Bit 2: DO 2		03h
			Bit 3: DO 3		04h
	Bit 7 ... 4: reserved				

4.6.1 Technical data

Order no.	022-1BD00
Type	SM 022
Module ID	0104 AFA0
Current consumption/power loss	
Current consumption from backplane bus	55 mA
Power loss	0.5 W
Technical data digital outputs	
Number of outputs	4
Cable length, shielded	1000 m
Cable length, unshielded	600 m
Rated load voltage	DC 20.4...28.8 V
Current consumption from load voltage L+ (without load)	10 mA
Total current per group, horizontal configuration, 40°C	2 A
Total current per group, horizontal configuration, 60°C	2 A
Total current per group, vertical configuration	2 A
Output current at signal "1", rated value	0.5 A
Output delay of "0" to "1"	30 µs
Output delay of "1" to "0"	175 µs
Minimum load current	-
Lamp load	10 W
Parallel switching of outputs for redundant control of a load	not possible
Parallel switching of outputs for increased power	not possible
Actuation of digital input	✓
Switching frequency with resistive load	max. 1000 Hz
Switching frequency with inductive load	max. 0.5 Hz
Switching frequency on lamp load	max. 10 Hz
Internal limitation of inductive shut-off voltage	L+ (-45 V)
Short-circuit protection of output	yes, electronic
Trigger level	1 A
Number of operating cycle of relay outputs	-
Switching capacity of contacts	-
Output data size	4 Bit
Status information, alarms, diagnostics	

Order no.	022-1BD00
Status display	green LED per channel
Interrupts	no
Process alarm	no
Diagnostic interrupt	no
Diagnostic functions	no
Diagnostics information read-out	none
Module state	green LED
Module error display	red SF LED
Channel error display	none
Isolation	
Between channels	-
Between channels of groups to	-
Between channels and backplane bus	✓
Insulation tested with	DC 500 V
Safety	
Safety protocol	-
Safety requirements	-
Secure user address	-
Watchdog	-
Two channels	-
Test pulse length	-
Circuit monitoring	-
Datasizes	
Input bytes	0
Output bytes	1
Parameter bytes	0
Diagnostic bytes	0
Housing	
Material	PPE / PPE GF10
Mounting	Profile rail 35 mm
Mechanical data	
Dimensions (WxHxD)	12.9 mm x 109 mm x 76.5 mm
Weight	60 g
Environmental conditions	
Operating temperature	0 °C to 60 °C
Storage temperature	-25 °C to 70 °C

022-1BD20 - DO 4xDC 24V 2A

Order no.	022-1BD00
Certifications	
UL508 certification	yes

4.7 022-1BD20 - DO 4xDC 24V 2A

Properties

The electronic module accepts binary control signals from the central bus system and transfers them to the process level via outputs. It has 4 channels and their status is monitored via LEDs.

- 4 digital 2A outputs, isolated to the backplane bus
- Status indication of the channels via LEDs

Structure

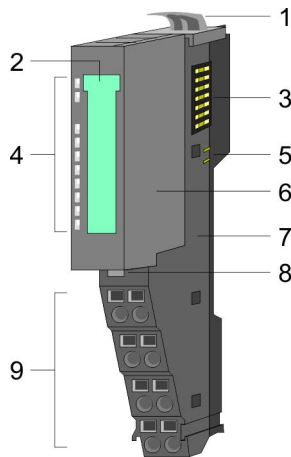

- 1 Locking lever terminal module
- 2 Labeling strip
- 3 Backplane bus
- 4 LED status indication
- 5 DC 24V power section supply
- 6 Electronic module
- 7 Terminal module
- 8 Locking lever electronic module
- 9 Terminal

Status indication

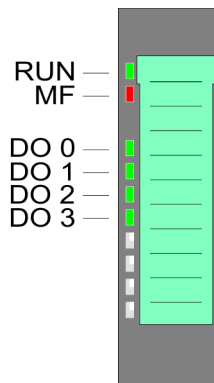

RUN	MF	DO x	Description
green	red	green	
■	■	■	
●	○	X	Bus communication is OK Module status is OK
●	●	X	Bus communication is OK Module status reports an error with over-load, short circuit or overheat
○	●	X	Bus communication is not possible Module status reports an error with over-load, short circuit or overheat
○	○	X	Error at bus power supply
X	B	X	Error in configuration ↪ Chapter 2.7 'Trouble shooting - LEDs' on page 28
●	○	●	Digital output has "1" signal

RUN	MF	DO x	Description
●	○	○	Digital output has "0" signal
on: ● off: ○ blinks with 2Hz: B not relevant: X			

Pin assignment

For wires with a cross section of 0.08mm² up to 1.5mm².

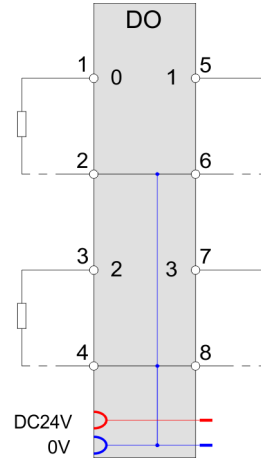
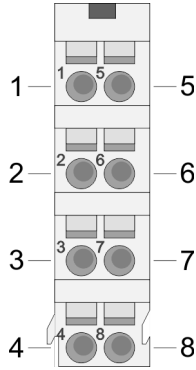

Pos.	Function	Type	Description
1	DO 0	O	Digital output DO 0
2	0V	O	GND for actuator DO 0
3	DO 2	O	Digital output DO 2
4	0V	O	GND for actuator DO 2
5	DO 1	O	Digital output DO 1
6	0V	O	GND for actuator DO 1
7	DO 3	O	Digital output DO 3
8	0V	O	GND for actuator DO 3

O: Output

Input area

No byte of the input area is used by the module.

Output area

At CPU, PROFIBUS and PROFINET the output area is embedded to the corresponding address area.

IX - Index for access via CANopen

SX - Subindex (7000h + EtherCAT-Slot) for access via EtherCAT

More can be found in the according manual of your bus coupler.

Addr.	Name	Bytes	Function	IX	SX
+0	PIQ	1	State of the outputs	5200h	
			Bit 0: DO 0		01h

Addr.	Name	Bytes	Function	IX	SX
			Bit 1: DO 1		02h
			Bit 2: DO 2		03h
			Bit 3: DO 3		04h
			Bit 7 ... 4: reserved		

4.7.1 Technical data

Order no.	022-1BD20
Type	SM 022
Module ID	0108 AFA0
Current consumption/power loss	
Current consumption from backplane bus	65 mA
Power loss	0.8 W
Technical data digital outputs	
Number of outputs	4
Cable length, shielded	1000 m
Cable length, unshielded	600 m
Rated load voltage	DC 20.4...28.8 V
Current consumption from load voltage L+ (without load)	20 mA
Total current per group, horizontal configuration, 40°C	4 A
Total current per group, horizontal configuration, 60°C	4 A
Total current per group, vertical configuration	4 A
Output current at signal "1", rated value	2 A
Output delay of "0" to "1"	100 µs
Output delay of "1" to "0"	250 µs
Minimum load current	-
Lamp load	10 W
Parallel switching of outputs for redundant control of a load	not possible
Parallel switching of outputs for increased power	not possible
Actuation of digital input	✓
Switching frequency with resistive load	max. 1000 Hz
Switching frequency with inductive load	max. 0.5 Hz
Switching frequency on lamp load	max. 10 Hz

Order no.	022-1BD20
Internal limitation of inductive shut-off voltage	L+ (-52 V)
Short-circuit protection of output	yes, electronic
Trigger level	2.7 A
Number of operating cycle of relay outputs	-
Switching capacity of contacts	-
Output data size	4 Bit
Status information, alarms, diagnostics	
Status display	green LED per channel
Interrupts	no
Process alarm	no
Diagnostic interrupt	no
Diagnostic functions	no
Diagnostics information read-out	none
Supply voltage display	green LED
Group error display	red SF LED
Channel error display	none
Isolation	
Between channels	-
Between channels of groups to	-
Between channels and backplane bus	✓
Insulation tested with	DC 500 V
PWM data	
PWM channels	-
PWM time basis	-
Period length	-
Minimum pulse width	-
PtP communication	-
Safety	
Safety protocol	-
Safety requirements	-
Secure user address	-
Watchdog	-
Two channels	-
Test pulse length	-
Circuit monitoring	-
Datasizes	

022-1BD50 - DO 4xDC 24V 0.5A NPN

Order no.	022-1BD20
Input bytes	0
Output bytes	1
Parameter bytes	0
Diagnostic bytes	0
Housing	
Material	PPE / PPE GF10
Mounting	Profile rail 35 mm
Mechanical data	
Dimensions (WxHxD)	12.9 mm x 109 mm x 76.5 mm
Weight	60 g
Environmental conditions	
Operating temperature	0 °C to 60 °C
Storage temperature	-25 °C to 70 °C
Certifications	
UL certification	yes

4.8 022-1BD50 - DO 4xDC 24V 0.5A NPN

Properties

The electronic module accepts binary control signals from the central bus system and transfers them to the process level via outputs. It has 4 channels connected to the power supply, which operate as low-side switch and their status is monitored via LEDs. Low-side switches are suited to switch grounds. With a short circuit between switch line and ground the load is activated but the power supply is not influenced.

- 4 digital low-side outputs, isolated to the backplane bus
- Status indication of the channels via LEDs

Structure

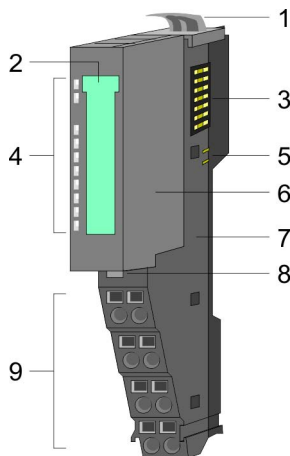

- 1 Locking lever terminal module
- 2 Labeling strip
- 3 Backplane bus
- 4 LED status indication
- 5 DC 24V power section supply
- 6 Electronic module
- 7 Terminal module
- 8 Locking lever electronic module
- 9 Terminal

Status indication

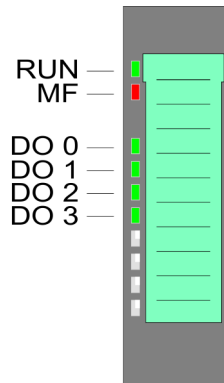

RUN	MF	DO x	Description
green	red	green	
●	○	X	Bus communication is OK Module status is OK
●	●	X	Bus communication is OK Module status reports an error with over- load, short circuit or overheat
○	●	X	Bus communication is not possible Module status reports an error with over- load, short circuit or overheat
○	○	X	Error at bus power supply
X	B	X	Error in configuration ↪ <i>Chapter 2.7</i> <i>'Trouble shooting - LEDs' on page 28</i>
●	○	●	Digital output has "1" signal
●	○	○	Digital output has "0" signal
on: ● off: ○ blinks with 2Hz: B not relevant: X			

Pin assignment

For wires with a cross section of 0.08mm² up to 1.5mm².

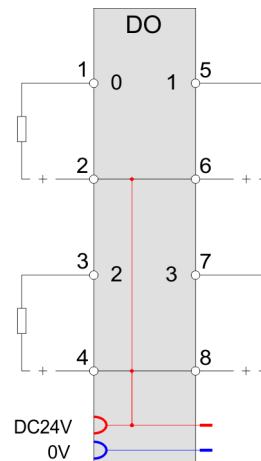
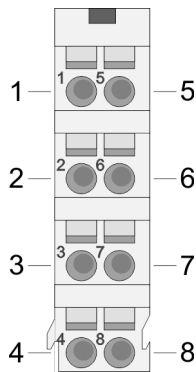

Pos.	Function	Type	Description
1	DO 0	O	Digital output DO 0
2	DC 24V	O	DC 24V for actuator DO 0
3	DO 2	O	Digital output DO 2
4	DC 24V	O	DC 24V for actuator DO 2
5	DO 1	O	Digital output DO 1
6	DC 24V	O	DC 24V for actuator DO 1
7	DO 3	O	Digital output DO 3
8	DC 24V	O	DC 24V for actuator DO 3

O: Output

Input area

No byte of the input area is used by the module.

Output area

At CPU, PROFIBUS and PROFINET the output area is embedded to the corresponding address area.

IX - Index for access via CANopen

SX - Subindex (7000h + EtherCAT-Slot) for access via EtherCAT

More can be found in the according manual of your bus coupler.

Addr.	Name	Bytes	Function	IX	SX
+0	PIQ	1	State of the outputs	5200h	
			Bit 0: DO 0		01h
			Bit 1: DO 1		02h
			Bit 2: DO 2		03h
			Bit 3: DO 3		04h
	Bit 7 ... 4: reserved				

4.8.1 Technical data

Order no.	022-1BD50
Type	SM 022
Module ID	0105 AFA0
Current consumption/power loss	
Current consumption from backplane bus	65 mA
Power loss	0.5 W
Technical data digital outputs	
Number of outputs	4
Cable length, shielded	1000 m
Cable length, unshielded	600 m
Rated load voltage	DC 20.4...28.8 V
Current consumption from load voltage L+ (without load)	5 mA
Total current per group, horizontal configuration, 40°C	2 A
Total current per group, horizontal configuration, 60°C	2 A
Total current per group, vertical configuration	2 A
Output current at signal "1", rated value	0.5 A
Output delay of "0" to "1"	30 µs
Output delay of "1" to "0"	100 µs
Minimum load current	-
Lamp load	10 W
Parallel switching of outputs for redundant control of a load	not possible
Parallel switching of outputs for increased power	not possible
Actuation of digital input	✓
Switching frequency with resistive load	max. 1000 Hz
Switching frequency with inductive load	max. 0.5 Hz
Switching frequency on lamp load	max. 10 Hz
Internal limitation of inductive shut-off voltage	+45 V
Short-circuit protection of output	yes, electronic
Trigger level	1.7 A
Number of operating cycle of relay outputs	-
Switching capacity of contacts	-
Output data size	4 Bit
Status information, alarms, diagnostics	

Order no.	022-1BD50
Status display	green LED per channel
Interrupts	no
Process alarm	no
Diagnostic interrupt	no
Diagnostic functions	no
Diagnostics information read-out	none
Supply voltage display	green LED
Group error display	red SF LED
Channel error display	none
Isolation	
Between channels	-
Between channels of groups to	-
Between channels and backplane bus	✓
Insulation tested with	DC 500 V
PWM data	
PWM channels	-
PWM time basis	-
Period length	-
Minimum pulse width	-
PtP communication	-
Safety	
Safety protocol	-
Safety requirements	-
Secure user address	-
Watchdog	-
Two channels	-
Test pulse length	-
Circuit monitoring	-
Datasizes	
Input bytes	0
Output bytes	1
Parameter bytes	0
Diagnostic bytes	0
Housing	
Material	PPE / PPE GF10
Mounting	Profile rail 35 mm

Order no.	022-1BD50
Mechanical data	
Dimensions (WxHxD)	12.9 mm x 109 mm x 76.5 mm
Weight	60 g
Environmental conditions	
Operating temperature	0 °C to 60 °C
Storage temperature	-25 °C to 70 °C
Certifications	
UL certification	yes

4.9 022-1BD70 - DO 4xDC 24V 0.5A ETS

Properties

The electronic module accepts binary control signals from the central bus system and transfers them time-controlled by means of ETS functionality to the process level via outputs. It has 4 channels and their status is monitored via LEDs. With configured ETS functionality (ETS = edge time stamp) depending on the configuration 5 (20byte) respectively 15 (60byte), you may transfer the states for the outputs together with a time value of the μ s ticker as an ETS entry to the FIFO stack. The FIFO memory serves for space for max. 31 ETS entries.

- 4 digital outputs, isolated to the backplane bus
- FIFO stack for 5 respectively 15 ETS entries (each 4byte)
- Diagnostics function
- Controlling by process image respectively handling blocks
- Status indication of the channels via LEDs

Structure

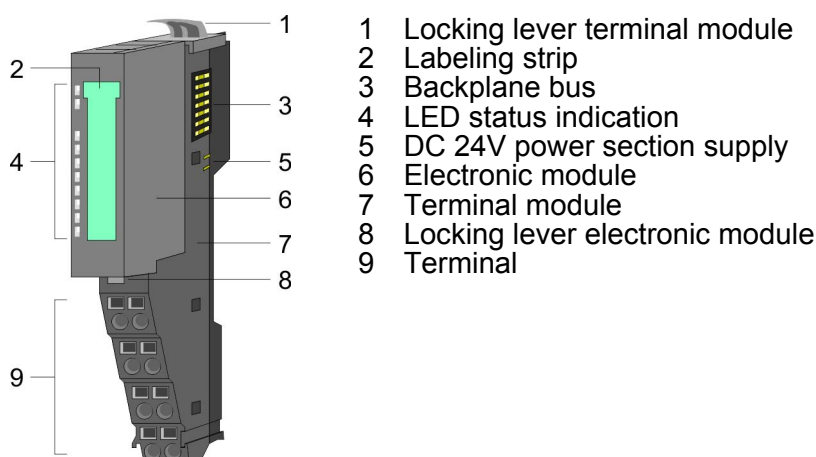

Status indication

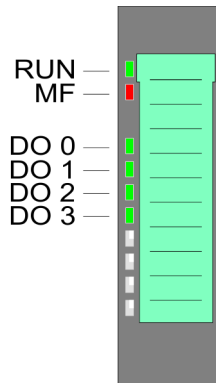

RUN	MF	DO x	Description
green	red	green	
●	○	X	Bus communication is OK Module status is OK
●	●	X	Bus communication is OK Module status reports an error with over- load, short circuit or overheat
○	●	X	Bus communication is not possible Module status reports an error with over- load, short circuit or overheat
○	○	X	Error at bus power supply
X	B	X	Error in configuration ↪ <i>Chapter 2.7</i> <i>'Trouble shooting - LEDs' on page 28</i>
●	○	●	Digital output has "1" signal
●	○	○	Digital output has "0" signal
on: ● off: ○ blinks with 2Hz: B not relevant: X			

Pin assignment

For wires with a cross section of 0.08mm² up to 1.5mm².

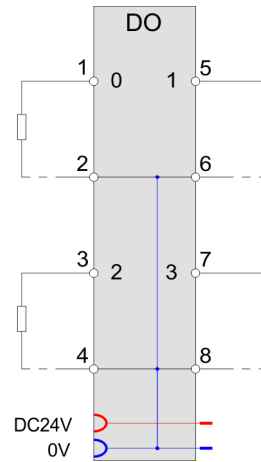
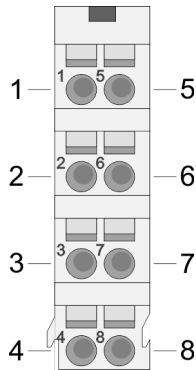

Pos.	Function	Type	Description
1	DO 0	O	Digital output DO 0
2	0V	O	GND for actuator DO 0
3	DO 2	O	Digital output DO 2
4	0V	O	GND for actuator DO 2
5	DO 1	O	Digital output DO 1
6	0V	O	GND for actuator DO 1
7	DO 3	O	Digital output DO 3
8	0V	O	GND for actuator DO 3

O: Output

In-/Output area

With configured ETS functionality (ETS=edge time stamp) a time value (ETS_US) together with the state of the outputs (PIQ) and a running number (RN) may be stored as ETS entry in the process image.

You may configure the following variants:

- 022-1BD70 DO 4xDC 24V (20):
FIFO with 20byte for 5 ETS entries
- 022-1BD70 DO 4xDC 24V (60):
FIFO with 60byte for 15 ETS entries



Please consider, with a full FIFO stack no further ETS entries may be accepted.

To ensure that your ETS entries are kept, you should always check the state of the FIFO stack by STS_FIFO in the input area before.

Input area 4byte

The input range is used for status message. At CPU, PROFIBUS and PROFINET the input area is embedded to the corresponding address area.

IX - IX = Index for access via CANopen.

SX - Subindex (6000h + EtherCAT-Slot) for access via EtherCAT

More can be found in the according manual of your bus coupler.

Addr.	Name	Bytes	Function	IX	SX
+0	RN_LAST	1	Bit 5 ... 0: RN last FIFO entry Bit 6: 1 (fix) Bit 7: 0 (fix)	5440h	01h
+1	RN_NEXT	1	Bit 5 ... 0: RN next FIFO entry to be processed Bit 6: 1 (fix) Bit 7: 1 (fix)		02h
+2	STS_FIFO	1	State of the FIFO stack		03h
+3	NUM_ETS	1	Number of ETS entries in the FIFO stack		04h

RN_LAST

Bit 5 ... 0: Here the RN of the last ETS entry may be found, which was recognized as valid and written into the FIFO memory of the module.

Bit 6: 1 (fix) - serves for the identification in the process image

Bit 7: 0 (fix) - serves for the identification in the process image

RN_NEXT

Bit 5 ... 0: Here the RN of the ETS entry may be found, which will be executed next in the FIFO memory of the module.

Please consider Bit 6 and 7 of RN_NEXT are always set.

Bit 6: 1 (fix) - serves for the identification in the process image

Bit 7: 1 (fix) - serves for the identification in the process image

STS_FIFO

The *State* informs about the state of the FIFO stack:

STS_FIFO	Description
00h/80h	Everything is OK. You will get this message directly after the storage in the FIFO memory of the module.
01h/81h	There is no following ETS entry in the FIFO. The RN does not correspond to the expected RN. Please check your RN in the output area.

STS_FIFO	Description
02h/82h	There are no new ETS entries in the FIFO.
03h/83h	FIFO stack is full. There is no more place for further ETS entries.

If there are less ETS entries written as possible, additionally bit 6 of the last RN must be set. This is necessary; otherwise you have to overwrite the following entries with a "not valid" entry. The module ignores entries after an entry with a set bit 6. If there is an ETS entry in the FIFO memory, whose bit 6 is set, STS_FIFO is always returned with 80h.

NUM_ETS

Here always the current number of the ETS entries in the FIFO memory of the module may be found.

Structure of an ETS entry

Depending on the configuration up to 15 ETS entries may be written via the output area. Each ETS entry uses 4byte in the process image:

Output area 20byte respectively 60byte

At CPU, PROFIBUS and PROFINET the output area is embedded to the corresponding address area.

IX - Index for access via CANopen. With s = Subindex the corresponding ETS entry is addressed.

SX - Subindex (7000h + EtherCAT-Slot) for access via EtherCAT

More can be found in the according manual of your bus coupler.

Addr.	Name	Bytes	Function	IX	SX
+0	PIQ	1	Output byte	5640h/s	01h
+1	RN	1	Running number		02h
+2	ETS_US	2	µs ticker		03h

PIQ

Here the state of the outputs for the corresponding time may be defined and the output channels may be enabled respectively disabled. The output byte has the following bit allocation:

- Bit 3 ... 0: 0 (fix)
- Bit 4: State DO 3
- Bit 5: State DO 2
- Bit 6: State DO 1
- Bit 7: State DO 0

RN

RN (**R**unning **N**umber) is a continuous number 0 ... 63, which has to start with 1. With the RN the chronological order of the ETS entries may be defined. With each ETS entry RN is to be incremented, otherwise the ETS entry may not be recognized by the module.



If there are less ETS entries written as possible, additionally bit 6 of the last RN must be set. This is necessary; otherwise you have to overwrite the following entries with a "not valid" entry. The module ignores entries after an entry with a set bit 6.

ETS_US

In the SLIO module there is a 32 bit timer (μ s ticker). With PowerON the timer starts counting. After $2^{32}-1\mu$ s the timer starts with 0 again. For ETS_US of an ETS entry you have to define a time value from the low word of the μ s ticker (0...65535 μ s).

Here please enter a time value in μ s, to which the state of the outputs is to be taken.

Range of values: 0 ... 65535

ETS functionality

The following picture shows how the ETS entries are to be preset in the output area, so that these can be stored in the FIFO memory.

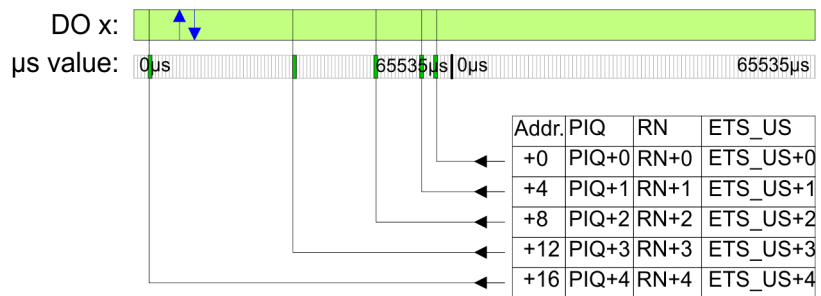

Output area 20byte respectively 60byte

At CPU, PROFIBUS and PROFINET the output area is embedded to the corresponding address area.

IX - Index for access via CANopen. With s = Subindex the corresponding ETS entry is addressed.

SX - Subindex (7000h + EtherCAT-Slot) for access via EtherCAT

More can be found in the according manual of your bus coupler.

Configured as 022-1BD70

DO 4xDC 24V (20)
20byte - 5 ETS entries

Addr.	PIQ	IX=5640h	SX	Addr.	RN	IX=5641h	SX	Addr.	ETS-US	IX=5642h	SX
+0	PIQ+0	s=1	01h	+1	RN+0	s=1	02h	+2	ETS_US+0	s=1	03h
+4	PIQ+1	s=2	04h	+5	RN+1	s=2	05h	+6	ETS_US+1	s=2	06h
+8	PIQ+2	s=3	07h	+9	RN+2	s=3	08h	+10	ETS_US+2	s=3	09h
+12	PIQ+3	s=4	0Ah	+13	RN+3	s=4	0Bh	+14	ETS_US+3	s=4	0Ch
+16	PIQ+4	s=5	0Dh	+17	RN+4	s=5	0Eh	+18	ETS_US+4	s=5	0Fh

**Configured as
022-1BD70**

DO 4xDC 24V (60)
60byte - 15 ETS entries

Addr.	PIQ	IX=5640h	SX	Addr.	RN	IX=5641h	SX	Addr.	ETS-US	IX=5642h	SX
+0	PIQ+0	s=1	01h	+1	RN+0	s=1	02h	+2	ETS_US+0	s=1	03h
+4	PIQ+1	s=2	04h	+5	RN+1	s=2	05h	+6	ETS_US+1	s=2	06h
+8	PIQ+2	s=3	07h	+9	RN+2	s=3	08h	+10	ETS_US+2	s=3	09h
+12	PIQ+3	s=4	0Ah	+13	RN+3	s=4	0Bh	+14	ETS_US+3	s=4	0Ch
+16	PIQ+4	s=5	0Dh	+17	RN+4	s=5	0Eh	+18	ETS_US+4	s=5	0Fh
+20	PIQ+5	s=6	10h	+21	RN+5	s=6	11h	+22	ETS_US+5	s=6	12h
+24	PIQ+6	s=7	13h	+25	RN+6	s=7	14h	+26	ETS_US+6	s=7	15h
+28	PIQ+7	s=8	16h	+29	RN+7	s=8	17h	+30	ETS_US+7	s=8	18h
+32	PIQ+8	s=9	19h	+33	RN+8	s=9	1Ah	+34	ETS_US+8	s=9	1Bh
+36	PIQ+9	s=10	1Ch	+37	RN+9	s=10	1Dh	+38	ETS_US+9	s=10	1Eh
+40	PIQ+10	s=11	1Fh	+41	RN+10	s=11	20h	+42	ETS_US+10	s=11	21h
+44	PIQ+11	s=12	22h	+45	RN+11	s=12	23h	+46	ETS_US+11	s=12	24h
+48	PIQ+12	s=13	25h	+49	RN+12	s=13	26h	+50	ETS_US+12	s=13	27h
+52	PIQ+13	s=14	28h	+53	RN+13	s=14	29h	+54	ETS_US+13	s=14	2Ah
+56	PIQ+14	s=15	2Bh	+57	RN+14	s=15	2Ch	+58	ETS_US+14	s=15	2Dh



The ETS module may only be accessed by the System SLIO CPU by means of SFC 15 or via the process image. Only the input data of the ETS module may be read by individual accesses.

4.9.1 Technical data

Order no.	022-1BD70
Type	SM 022
Module ID	0F43 57E2
Current consumption/power loss	
Current consumption from backplane bus	90 mA
Power loss	0.95 W
Technical data digital outputs	
Number of outputs	4
Cable length, shielded	1000 m
Cable length, unshielded	600 m

Order no.	022-1BD70
Rated load voltage	DC 20.4...28.8 V
Current consumption from load voltage L+ (without load)	25 mA
Total current per group, horizontal configuration, 40°C	2 A
Total current per group, horizontal configuration, 60°C	2 A
Total current per group, vertical configuration	2 A
Output current at signal "1", rated value	0.5 A
Output delay of "0" to "1"	max. 100 ns
Output delay of "1" to "0"	max. 100 ns
Minimum load current	-
Lamp load	10 W
Parallel switching of outputs for redundant control of a load	not possible
Parallel switching of outputs for increased power	not possible
Actuation of digital input	✓
Switching frequency with resistive load	max. 40 kHz
Switching frequency with inductive load	max. 40 kHz
Switching frequency on lamp load	max. 40 kHz
Internal limitation of inductive shut-off voltage	L+ (-52 V)
Short-circuit protection of output	yes, electronic, and only highside
Trigger level	2.5 A
Number of operating cycle of relay outputs	-
Switching capacity of contacts	-
Output data size	60 Byte
Status information, alarms, diagnostics	
Status display	green LED per channel
Interrupts	no
Process alarm	no
Diagnostic interrupt	no
Diagnostic functions	no
Diagnostics information read-out	possible
Supply voltage display	green LED
Group error display	red SF LED
Channel error display	none
Isolation	

Order no.	022-1BD70
Between channels	-
Between channels of groups to	-
Between channels and backplane bus	✓
Insulation tested with	DC 500 V
PWM data	
PWM channels	-
PWM time basis	-
Period length	-
Minimum pulse width	-
PtP communication	-
Safety	
Safety protocol	-
Safety requirements	-
Secure user address	-
Watchdog	-
Two channels	-
Test pulse length	-
Circuit monitoring	-
Datasizes	
Input bytes	4
Output bytes	20 / 60
Parameter bytes	6
Diagnostic bytes	20
Housing	
Material	PPE / PPE GF10
Mounting	Profile rail 35 mm
Mechanical data	
Dimensions (WxHxD)	12.9 mm x 109 mm x 76.5 mm
Weight	60 g
Environmental conditions	
Operating temperature	0 °C to 60 °C
Storage temperature	-25 °C to 70 °C
Certifications	
UL certification	yes

4.9.2 Parameter data

4.9.2.1 Parameters

The module has the following parameter data, which were fix set and may not be altered.

DS - Record set for access via CPU, PROFIBUS and PROFINET

IX - Index for access via CANopen

SX - Subindex (3100h + EtherCAT-Slot) for access via EtherCAT

More can be found in the according manual of your bus coupler.

Name	Bytes	Function	Default	DS	IX	SX
PII_L	1	Length process image input data ¹	04h (fix)	02h	3100h	01h
PIQ_L	1	Length process image output data ^{1, 2}	14h resp. 3Ch (fix)	02h	3101h	02h

1) This record set may only be transferred at STOP state.

2) This parameter depends on the configured variant.

PII_L

Byte	Bit 7 ... 0
0	The length of the process image of the input data is fix set to 4byte.

PIQ_L

Byte	Bit 7 ... 0
0	The length of the process image of the output data is fix set to the configured variant (14h or 3Ch).

4.9.2.2 Example for the principle of operation

In the following it is demonstrated by an example, in which order the ETS entries are stored and processed.

With this example a module is configured, which uses 20byte for 5 ETS entries in the output area PIQ.

ETS values

With the following times of the μ s ticker the following states of the outputs should be taken:

RN	ETS_US in μ s	PIQ DO 0 (Bit 7)	PIQ DO 1 (Bit 6)	PIQ DO 2 (Bit 5)	PIQ DO 3 (Bit 4)
01h	6000	0	0	1	1
02h	12506	1	0	1	1
03h	34518	1	1	1	1

RN	ETS_US in μ s	PIQ DO 0 (Bit 7)	PIQ DO 1 (Bit 6)	PIQ DO 2 (Bit 5)	PIQ DO 3 (Bit 4)
04h	49526	0	0	1	1
05h	54529	0	1	1	1
06h	3500	1	1	1	1
07h	12443	1	0	1	1
08h	20185	0	0	1	1
09h	30140	1	0	1	1
0Ah	37330	0	0	1	1
0Bh	40000	0	0	0	0

Time diagram

From the table you get the following time diagram:

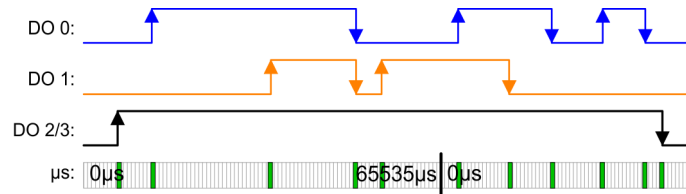

Writing 5 ETS entries

After writing the ETS entries into the process output image they are directly stored in the FIFO memory of the module.

The state of the outputs are shown in the diagram at the time "t".

In the PII you will find the status bytes.

Addr.	PIQ	RN	ETS_US	→	FIFO	PIQ	RN	ETS_US	PII
+0	00110000	01h	6000		1	00110000	01h	6000	RN_LAST: 45h
+4	10110000	02h	12506		2	10110000	02h	12506	RN_NEXT: C1h
+8	11110000	03h	34518		3	11110000	03h	34518	STS_FIFO: 00h
+12	00110000	04h	49526		4	00110000	04h	49526	NUM_ETS: 05h
+16	01110000	05h	54529		5	01110000	05h	54529	
					6	00000000	00h	0	
					7	00000000	00h	0	
					8	00000000	00h	0	
					9	00000000	00h	0	
					...	00000000	00h	0	
					31	00000000	00h	0	

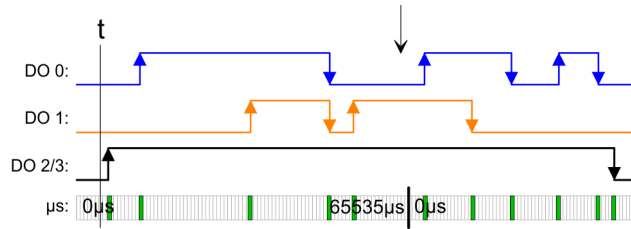

Executing ETS function for RN = 01h

The 1. ETS entry (RN = 01h) is executed and deleted in the FIFO.

Addr.	PIQ	RN	ETS_US		FIFO	PIQ	RN	ETS_US	PII
+0	00110000	01h	6000	→	1	10110000	02h	12506	RN_LAST: 45h
+4	10110000	02h	12506		2	11110000	03h	34518	RN_NEXT: C2h
+8	11110000	03h	34518		3	00110000	04h	49526	STS_FIFO: 00h/02h
+12	00110000	04h	49526		4	01110000	05h	54529	NUM_ETS: 04h
+16	01110000	05h	54529		5	00000000	00h	0	
					6	00000000	00h	0	
					7	00000000	00h	0	
					8	00000000	00h	0	
					9	00000000	00h	0	
					...	00000000	00h	0	
					31	00000000	00h	0	

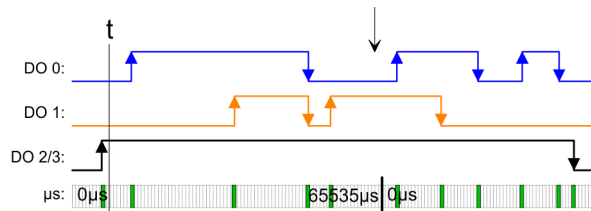

Executing ETS function for RN = 02h ... 04h

The states of RN = 02h ... RN 04h are successively issued and deleted in the FIFO.

Addr.	PIQ	RN	ETS_US		FIFO	PIQ	RN	ETS_US	PII
+0	00110000	01h	6000	→	1	01110000	05h	54529	RN_LAST: 45h
+4	10110000	02h	12506		2	00000000	00h	0	RN_NEXT: C5h
+8	11110000	03h	34518		3	00000000	00h	0	STS_FIFO: 00h/02h
+12	00110000	04h	49526		4	00000000	00h	0	NUM_ETS: 01h
+16	01110000	05h	54529		5	00000000	00h	0	
					6	00000000	00h	0	
					7	00000000	00h	0	

	8	00000000	00h	0
	9	00000000	00h	0
	...	00000000	00h	0
	31	00000000	00h	0

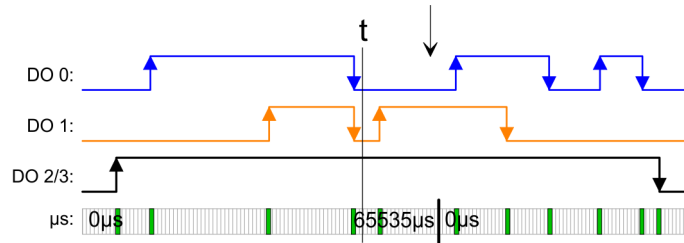

Writing 5 ETS entries

After writing the next 5 ETS entries into the process output image they are directly stored in the FIFO memory of the module.

Addr.	PIQ	RN	ETS_US		FIFO	PIQ	RN	ETS_US	PII
+0	11110000	06h	3500	→	1	01110000	05h	54529	RN_LAST: 4Ah
+4	10110000	07h	12443		2	11110000	06h	3500	RN_NEXT: C5h
+8	00110000	08h	20185		3	10110000	07h	12443	STS_FIFO: 00h/ 02h
+12	10110000	09h	30140		4	00110000	08h	20185	NUM_ETS: 06h
+16	00110000	0Ah	37330		5	10110000	09h	30140	
					6	00110000	0Ah	37330	
					7	00000000	00h	0	
					8	00000000	00h	0	
					9	00000000	00h	0	
					...	00000000	00h	0	
					31	00000000	00h	0	

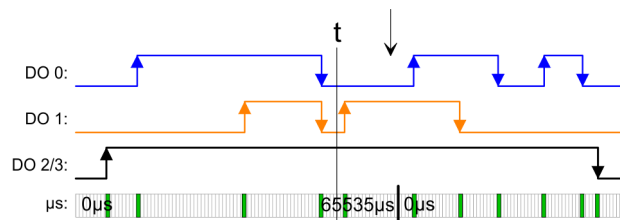

Executing ETS function for RN = 06h ... 08h

The states of RN = 06h ... RN 08h are successively issued and deleted in the FIFO.

Addr.	PIQ	RN	ETS_US		FIFO	PIQ	RN	ETS_US	PII
+0	11110000	06h	3500	→	1	10110000	09h	30140	RN_LAST: 4Ah
+4	10110000	07h	12443		2	00110000	0Ah	37330	RN_NEXT: C5h

022-1BD70 - DO 4xDC 24V 0.5A ETS > Parameter data

+8	00110000	08h	20185		3	00000000	00h	0	STS_FIFO: 00h/ 02h NUM_ETS: 02h
+12	10110000	09h	30140		4	00000000	00h	0	
+16	00110000	0Ah	37330		5	00000000	00h	0	
					6	00000000	00h	0	
					7	00000000	00h	0	
					8	00000000	00h	0	
					9	00000000	00h	0	
					...	00000000	00h	0	
				31	00000000	00h	0		

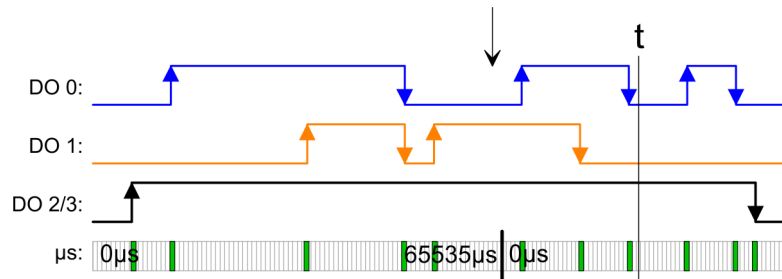

Writing last ETS entry

Since less than 5 ETS entries are written, bit 6 of RN of the last ETS entry must always be set. RN = 0Bh becomes 4Bh.

Addr.	PIQ	RN	ETS_US		FIFO	PIQ	RN	ETS_US	PII
+0	00000000	4Bh	40000	→	1	10110000	09h	30140	RN_LAST: 4Bh
+4	10110000	07h	12443		2	00110000	0Ah	37330	RN_NEXT: C9h
+8	00110000	08h	20185		3	00000000	4Bh	40000	STS_FIFO: 80h/ 82h
+12	10110000	09h	30140		4	00000000	00h	0	NUM_ETS: 03h
+16	00110000	0Ah	37330		5	00000000	00h	0	
					6	00000000	00h	0	
					7	00000000	00h	0	
					8	00000000	00h	0	
					9	00000000	00h	0	
					...	00000000	00h	0	
					31	00000000	00h	0	

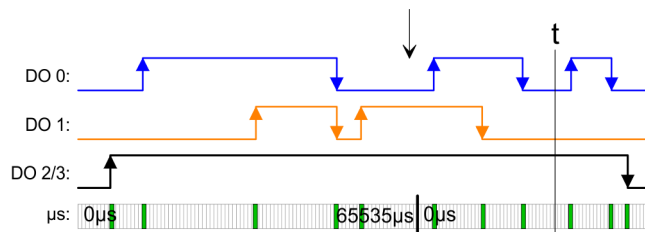

Executing ETS function for RN = 09h ... 4Bh

The states of RN = 09h ... RN 4Bh are successively issued and deleted in the FIFO.

Addr.	PIQ	RN	ETS_US		FIFO	PIQ	RN	ETS_US	PII
+0	00000000	4Bh	40000	→	1	00000000	00h	0	RN_LAST: 4Bh
+4	10110000	07h	12443		2	00000000	00h	0	RN_NEXT: CCh
+8	00110000	08h	20185		3	00000000	00h	0	STS_FIFO: 80h/ 82h
+12	10110000	09h	30140		4	00000000	00h	0	NUM_ETS: 00h
+16	00110000	0Ah	37330		5	00000000	00h	0	
					6	00000000	00h	0	
					7	00000000	00h	0	
					8	00000000	00h	0	
					9	00000000	00h	0	
					...	00000000	00h	0	
					31	00000000	00h	0	

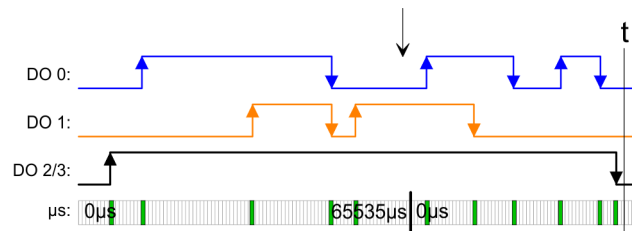

Please consider the ETS modules can only effectively be used together with head modules, which have an integrated μ s ticker. The Ethernet coupler with ModbusTCP 053-1MT00 for example does not have an μ s ticker.

4.9.3 Diagnostic data

This module does not support interrupt functions, the diagnostic data serve the information about this module.

DS - Record set for access via CPU, PROFIBUS and PROFINET. The access happens by DS 01h. Additionally the first 4 bytes may be accessed by DS 00h.

IX - Index for access via CANopen. The access happens by IX 2F01h. Additionally the first 4 bytes may be accessed by IX 2F00h.

SX - Subindex (5005h) for access via EtherCAT.

More can be found in the according manual of your bus coupler.

Name	Bytes	Function	Default	DS	IX	SX
ERR_A	1	reserved	00h	01h	2F01h	02h
MODTYP	1	Module information	1Fh			03h
ERR_C	1	reserved	00h			04h
ERR_D	1	reserved	00h			05h
CHTYP	1	Channel type	72h			06h
NUMBIT	1	Number of diagnostics bits per channel	00h			07h
NUMCH	1	Number channels of the module	04h			08h
CHERR	1	reserved	00h			09h
CH0ERR... CH7ERR	8	reserved	00h			0Ah ... 11h
DIAG_US	4	µs ticker (32bit)	00h			13h

MODTYP Modul information

Byte	Bit 7 ... 0
0	Bit 3 ... 0: Module class 1111b Digital module Bit 4: Channel information present Bit 7 ... 5: reserved

CHTYP Channel type

Byte	Bit 7 ... 0
0	Bit 6 ... 0: Channel type 72h: Digital output Bit 7: 0 (fix)

NUMBIT Diagnostic bits

Byte	Bit 7 ... 0
0	Number of diagnostics bits of the module per channel (here 00h)

NUMCH Number of channels

Byte	Bit 7 ... 0
0	Number of channels of the module (here 04h)

DIAG_US µs ticker

Byte	Bit 7 ... 0
0 ... 3	Value of the µs ticker at the moment of the diagnostic data generation

**ERR_A/C/D CHERR,
CHxERR reserved**

Byte	Bit 7 ... 0
0	reserved

4.10 022-1BF00 - DO 8xDC 24V 0.5A

Properties

The electronic module accepts binary control signals from the central bus system and transfers them to the process level via outputs. It has 8 channels and their status is monitored via LEDs.

- 8 digital outputs, isolated to the backplane bus
- Status indication of the channels via LEDs

Structure

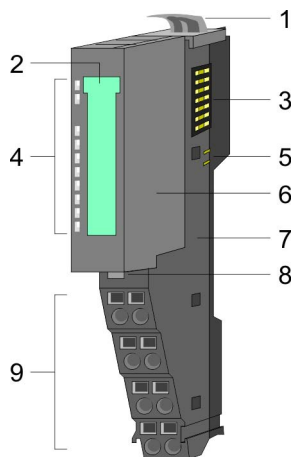

- 1 Locking lever terminal module
- 2 Labeling strip
- 3 Backplane bus
- 4 LED status indication
- 5 DC 24V power section supply
- 6 Electronic module
- 7 Terminal module
- 8 Locking lever electronic module
- 9 Terminal

Status indication

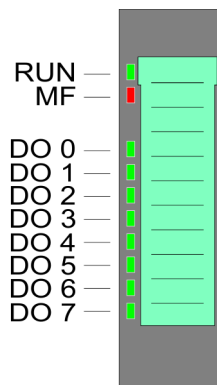

RUN	MF	DO x	Description
green	red	green	
■	■	■	
●	○	X	Bus communication is OK Module status is OK
●	●	X	Bus communication is OK Module status reports an error with over-load, short circuit or overheat
○	●	X	Bus communication is not possible Module status reports an error with over-load, short circuit or overheat
○	○	X	Error at bus power supply
X	B	X	Error in configuration ↪ <i>Chapter 2.7 'Trouble shooting - LEDs' on page 28</i>
●	○	●	Digital output has "1" signal
●	○	○	Digital output has "0" signal
on: ● off: ○ blinks with 2Hz: B not relevant: X			

Pin assignment

For wires with a cross section of 0.08mm² up to 1.5mm².

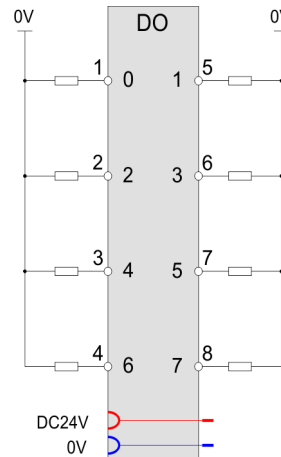
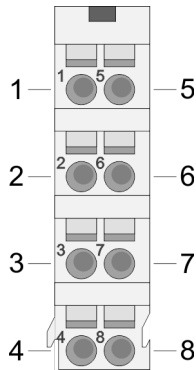

Pos.	Function	Type	Description
1	DO 0	O	Digital output DO 0
2	DO 2	O	Digital output DO 2
3	DO 4	O	Digital output DO 4
4	DO 6	O	Digital output DO 6
5	DO 1	O	Digital output DO 1
6	DO 3	O	Digital output DO 3
7	DO 5	O	Digital output DO 5
8	DO 7	O	Digital output DO 7

O: Output

Input area

No byte of the input area is used by the module.

Output area

At CPU, PROFIBUS and PROFINET the output area is embedded to the corresponding address area.

IX - Index for access via CANopen

SX - Subindex (7000h + EtherCAT-Slot) for access via EtherCAT

More can be found in the according manual of your bus coupler.

Addr.	Name	Bytes	Function	IX	SX
+0	PIQ	1	State of the outputs	6200h	
			Bit 0: DO 0		01h
			Bit 1: DO 1		02h
			Bit 2: DO 2		03h
			Bit 3: DO 3		04h
	Bit 4: DO 4	05h			

Addr.	Name	Bytes	Function	IX	SX
			Bit 5: DO 5		06h
			Bit 6: DO 6		07h
			Bit 7: DO 7		08h

4.10.1 Technical data

Order no.	022-1BF00
Type	SM 022
Module ID	0106 AFC8
Current consumption/power loss	
Current consumption from backplane bus	65 mA
Power loss	0.7 W
Technical data digital outputs	
Number of outputs	8
Cable length, shielded	1000 m
Cable length, unshielded	600 m
Rated load voltage	DC 20.4...28.8 V
Current consumption from load voltage L+ (without load)	15 mA
Total current per group, horizontal configuration, 40°C	4 A
Total current per group, horizontal configuration, 60°C	4 A
Total current per group, vertical configuration	4 A
Output current at signal "1", rated value	0.5 A
Output delay of "0" to "1"	30 µs
Output delay of "1" to "0"	175 µs
Minimum load current	-
Lamp load	10 W
Parallel switching of outputs for redundant control of a load	not possible
Parallel switching of outputs for increased power	not possible
Actuation of digital input	✓
Switching frequency with resistive load	max. 1000 Hz
Switching frequency with inductive load	max. 0.5 Hz
Switching frequency on lamp load	max. 10 Hz
Internal limitation of inductive shut-off voltage	L+ (-45 V)

Order no.	022-1BF00
Short-circuit protection of output	yes, electronic
Trigger level	1 A
Number of operating cycle of relay outputs	-
Switching capacity of contacts	-
Output data size	8 Bit
Status information, alarms, diagnostics	
Status display	green LED per channel
Interrupts	no
Process alarm	no
Diagnostic interrupt	no
Diagnostic functions	no
Diagnostics information read-out	none
Supply voltage display	green LED
Group error display	red SF LED
Channel error display	none
Isolation	
Between channels	-
Between channels of groups to	-
Between channels and backplane bus	✓
Insulation tested with	DC 500 V
PWM data	
PWM channels	-
PWM time basis	-
Period length	-
Minimum pulse width	-
PtP communication	-
Safety	
Safety protocol	-
Safety requirements	-
Secure user address	-
Watchdog	-
Two channels	-
Test pulse length	-
Circuit monitoring	-
Datasizes	
Input bytes	0

Order no.	022-1BF00
Output bytes	1
Parameter bytes	0
Diagnostic bytes	0
Housing	
Material	PPE / PPE GF10
Mounting	Profile rail 35 mm
Mechanical data	
Dimensions (WxHxD)	12.9 mm x 109 mm x 76.5 mm
Weight	60 g
Environmental conditions	
Operating temperature	0 °C to 60 °C
Storage temperature	-25 °C to 70 °C
Certifications	
UL certification	yes

4.11 022-1BF50 - DO 8xDC 24V 0.5A NPN

Properties

The electronic module accepts binary control signals from the central bus system and transfers them to the process level via outputs. It has 8 channels connected to the power supply, which operate as low-side switch and their status is monitored via LEDs. Low-side switches are suited to switch grounds. With a short circuit between switch line and ground the load is activated but the power supply is not influenced.

- 8 digital low-side outputs, isolated to the backplane bus
- Status indication of the channels via LEDs

Structure

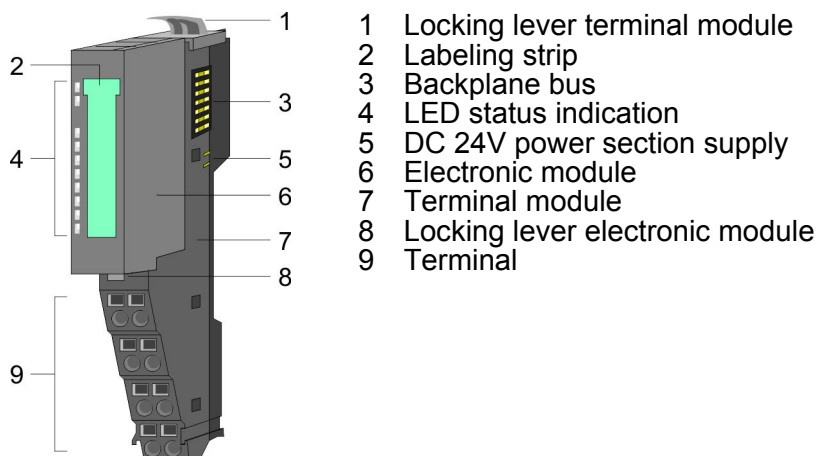

- 1 Locking lever terminal module
- 2 Labeling strip
- 3 Backplane bus
- 4 LED status indication
- 5 DC 24V power section supply
- 6 Electronic module
- 7 Terminal module
- 8 Locking lever electronic module
- 9 Terminal

Status indication

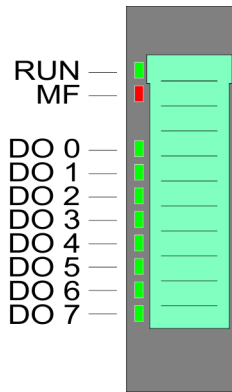

RUN	MF	DO x	Description
green	red	green	
●	○	X	Bus communication is OK Module status is OK
●	●	X	Bus communication is OK Module status reports an error with over- load, short circuit or overheat
○	●	X	Bus communication is not possible Module status reports an error with over- load, short circuit or overheat
○	○	X	Error at bus power supply
X	B	X	Error in configuration ↪ <i>Chapter 2.7</i> <i>'Trouble shooting - LEDs' on page 28</i>
●	○	●	Digital output has "1" signal
●	○	○	Digital output has "0" signal
on: ● off: ○ blinks with 2Hz: B not relevant: X			

Pin assignment

For wires with a cross section of 0.08mm² up to 1.5mm².

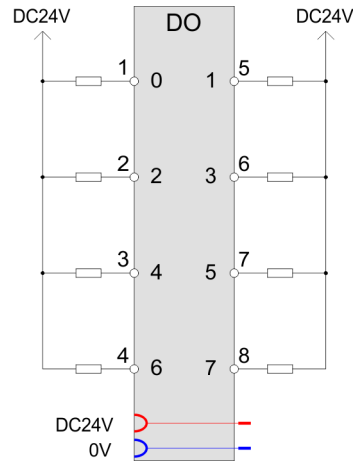
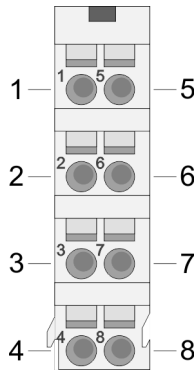

Pos.	Function	Type	Description
1	DO 0	O	Digital output DO 0
2	DO 2	O	Digital output DO 2
3	DO 4	O	Digital output DO 4
4	DO 6	O	Digital output DO 6
5	DO 1	O	Digital output DO 1
6	DO 3	O	Digital output DO 3
7	DO 5	O	Digital output DO 5
8	DO 7	O	Digital output DO 7

O: Output

Input area

No byte of the input area is used by the module.

Output area

At CPU, PROFIBUS and PROFINET the output area is embedded to the corresponding address area.

IX - Index for access via CANopen

SX - Subindex (7000h + EtherCAT-Slot) for access via EtherCAT

More can be found in the according manual of your bus coupler.

Addr.	Name	Bytes	Function	IX	SX
+0	PIQ	1	State of the outputs	6200h	
			Bit 0: DO 0		01h
			Bit 1: DO 1		02h
			Bit 2: DO 2		03h
			Bit 3: DO 3		04h
	Bit 4: DO 4	05h			

Addr.	Name	Bytes	Function	IX	SX
			Bit 5: DO 5		06h
			Bit 6: DO 6		07h
			Bit 7: DO 7		08h

4.11.1 Technical data

Order no.	022-1BF50
Type	SM 022
Module ID	0107 AFC8
Current consumption/power loss	
Current consumption from backplane bus	70 mA
Power loss	0.6 W
Technical data digital outputs	
Number of outputs	8
Cable length, shielded	1000 m
Cable length, unshielded	600 m
Rated load voltage	DC 20.4...28.8 V
Current consumption from load voltage L+ (without load)	10 mA
Total current per group, horizontal configuration, 40°C	2.5 A
Total current per group, horizontal configuration, 60°C	2.5 A
Total current per group, vertical configuration	2.5 A
Output current at signal "1", rated value	0.5 A
Output delay of "0" to "1"	30 µs
Output delay of "1" to "0"	100 µs
Minimum load current	-
Lamp load	10 W
Parallel switching of outputs for redundant control of a load	not possible
Parallel switching of outputs for increased power	not possible
Actuation of digital input	✓
Switching frequency with resistive load	max. 1000 Hz
Switching frequency with inductive load	max. 0.5 Hz
Switching frequency on lamp load	max. 10 Hz
Internal limitation of inductive shut-off voltage	+45 V

Order no.	022-1BF50
Short-circuit protection of output	yes, electronic
Trigger level	1.7 A
Number of operating cycle of relay outputs	-
Switching capacity of contacts	-
Output data size	8 Bit
Status information, alarms, diagnostics	
Status display	green LED per channel
Interrupts	no
Process alarm	no
Diagnostic interrupt	no
Diagnostic functions	no
Diagnostics information read-out	none
Supply voltage display	green LED
Group error display	red LED
Channel error display	none
Isolation	
Between channels	-
Between channels of groups to	-
Between channels and backplane bus	✓
Insulation tested with	DC 500 V
PWM data	
PWM channels	-
PWM time basis	-
Period length	-
Minimum pulse width	-
PtP communication	-
Safety	
Safety protocol	-
Safety requirements	-
Secure user address	-
Watchdog	-
Two channels	-
Test pulse length	-
Circuit monitoring	-
Datasizes	
Input bytes	0

022-1DF00 - DO 8xDC 24V 0.5A Diagnostic

Order no.	022-1BF50
Output bytes	1
Parameter bytes	0
Diagnostic bytes	0
Housing	
Material	PPE / PPE GF10
Mounting	Profile rail 35 mm
Mechanical data	
Dimensions (WxHxD)	12.9 mm x 109 mm x 76.5 mm
Weight	60 g
Environmental conditions	
Operating temperature	0 °C to 60 °C
Storage temperature	-25 °C to 70 °C
Certifications	
UL certification	yes

4.12 022-1DF00 - DO 8xDC 24V 0.5A Diagnostic

Properties

The electronic module with diagnosis accepts binary control signals from the central bus system and transfers them to the process level via outputs. It has 8 channels and their status is monitored via LEDs.

- 8 digital outputs, isolated to the backplane bus
- Monitoring wire-break and short-circuit
- Diagnostics function
- Status indication of the channels via LEDs

Structure

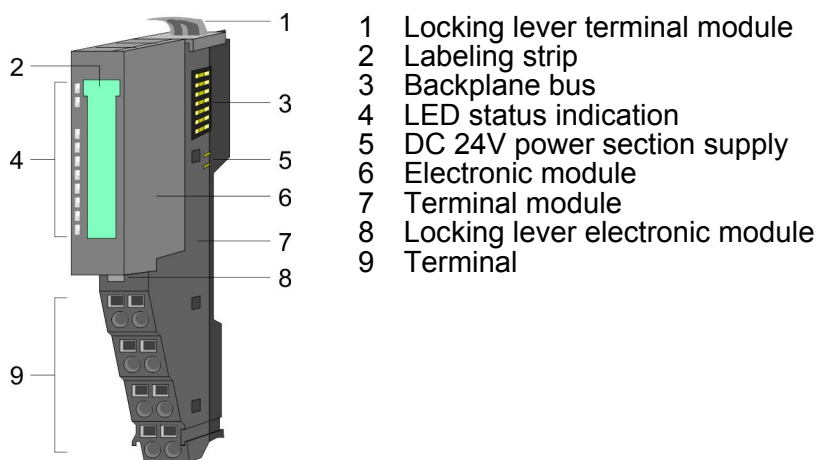

Status indication

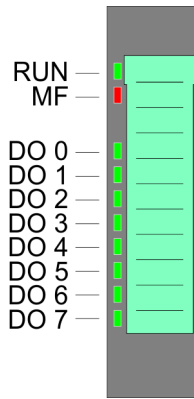

RUN	MF	DO x	Description
green ■	red ■	green ■	
●	○	X	Bus communication is OK Module status is OK
●	●	X	Bus communication is OK Module status reports an error with over- load, short circuit or overheat
○	●	X	Bus communication is not possible Module status reports an error with over- load, short circuit or overheat
○	○	X	Error at bus power supply
X	B	X	Error in configuration ↪ <i>Chapter 2.7</i> <i>'Trouble shooting - LEDs' on page 28</i>
●	○	●	Digital output has "1" signal
●	○	○	Digital output has "0" signal
on: ● off: ○ blinks with 2Hz: B not relevant: X			

Pin assignment

For wires with a cross section of 0.08mm² up to 1.5mm².

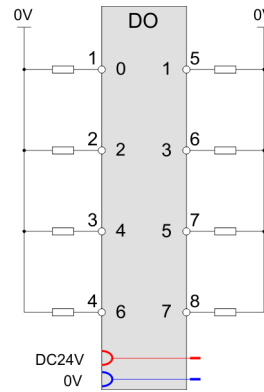
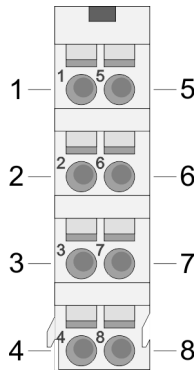

Pos.	Function	Type	Description
1	DO 0	O	Digital output DO 0
2	DO 2	O	Digital output DO 2
3	DO 4	O	Digital output DO 4
4	DO 6	O	Digital output DO 6
5	DO 1	O	Digital output DO 1
6	DO 3	O	Digital output DO 3
7	DO 5	O	Digital output DO 5
8	DO 7	O	Digital output DO 7

O: Output

Input area

No byte of the input area is used by the module.

Output area

At CPU, PROFIBUS and PROFINET the output area is embedded to the corresponding address area.

IX - Index for access via CANopen

SX - Subindex (7000h + EtherCAT-Slot) for access via EtherCAT

More can be found in the according manual of your bus coupler.

Addr.	Name	Bytes	Function	IX	SX
+0	PIQ	1	State of the outputs	6200h	
			Bit 0: DO 0		01h
			Bit 1: DO 1		02h
			Bit 2: DO 2		03h
			Bit 3: DO 3		04h
			Bit 4: DO 4		05h
			Bit 5: DO 5		06h

Addr.	Name	Bytes	Function	IX	SX
			Bit 6: DO 6		07h
			Bit 7: DO 7		08h

4.12.1 Technical data

Order no.	022-1DF00
Type	SM 022
Module ID	0113 2F48
Current consumption/power loss	
Current consumption from backplane bus	65 mA
Power loss	1 W
Technical data digital outputs	
Number of outputs	8
Cable length, shielded	1000 m
Cable length, unshielded	600 m
Rated load voltage	DC 20.4...28.8 V
Current consumption from load voltage L+ (without load)	11 mA
Total current per group, horizontal configuration, 40°C	4 A
Total current per group, horizontal configuration, 60°C	4 A
Total current per group, vertical configuration	4 A
Output current at signal "1", rated value	0.5 A
Output delay of "0" to "1"	max. 350 µs
Output delay of "1" to "0"	max. 350 µs
Minimum load current	-
Lamp load	10 W
Parallel switching of outputs for redundant control of a load	not possible
Parallel switching of outputs for increased power	not possible
Actuation of digital input	✓
Switching frequency with resistive load	max. 1000 Hz
Switching frequency with inductive load	max. 0.5 Hz
Switching frequency on lamp load	max. 10 Hz
Internal limitation of inductive shut-off voltage	L+ (-52 V)
Short-circuit protection of output	yes, electronic

Order no.	022-1DF00
Trigger level	1 A
Number of operating cycle of relay outputs	-
Switching capacity of contacts	-
Output data size	8 Bit
Status information, alarms, diagnostics	
Status display	green LED per channel
Interrupts	yes, parameterizable
Process alarm	no
Diagnostic interrupt	yes, parameterizable
Diagnostic functions	yes
Diagnostics information read-out	possible
Supply voltage display	green LED
Group error display	red SF LED
Channel error display	none
Isolation	
Between channels	-
Between channels of groups to	-
Between channels and backplane bus	✓
Insulation tested with	DC 500 V
PWM data	
PWM channels	-
PWM time basis	-
Period length	-
Minimum pulse width	-
PtP communication	-
Safety	
Safety protocol	-
Safety requirements	-
Secure user address	-
Watchdog	-
Two channels	-
Test pulse length	-
Circuit monitoring	-
Datasizes	
Input bytes	0
Output bytes	1

Order no.	022-1DF00
Parameter bytes	7
Diagnostic bytes	20
Housing	
Material	PPE / PPE GF10
Mounting	Profile rail 35 mm
Mechanical data	
Dimensions (WxHxD)	12.9 mm x 109 mm x 76.5 mm
Weight	60 g
Environmental conditions	
Operating temperature	0 °C to 60 °C
Storage temperature	-25 °C to 70 °C
Certifications	
UL certification	in preparation

4.12.2 Parameter data

DS - Record set for access via CPU, PROFIBUS and PROFINET

IX - Index for access via CANopen

SX - Subindex (3100h + EtherCAT-Slot) for access via EtherCAT

More can be found in the according manual of your bus coupler.

Name	Bytes	Function	Default	DS	IX	SX
DIAG_EN	1	Diagnostics*	00h	00h	3100h	01h
WIBRK_EN	1	Wire-break recognition*	00h	00h	3101h	02h
CH0D_EN	1	Short-circuit recognition*	00h	00h	3102h	03h

*) This record set may only be transferred at STOP state.

DIAG_EN Diagnostic interrupt

Byte	Bit 7 ... 0
0	Diagnostic interrupt 00h: disable 40h: enable

- Here you activate res. de-activate the diagnostic function.

WIBRK_EN Wire-break recognition

Byte	Bit 7 ... 0
0	Bit 0: Wire-break recognition channel 0 (1: on) Bit 1: Wire-break recognition channel 1 (1: on) ... Bit 7: Wire-break recognition channel 7 (1: on)

- Here you activate res. de-activate the Wire-break recognition.

CH0D_EN Short-circuit recognition

Byte	Bit 7 ... 0
0	Bit 0: Short-circuit recognition channel 0 (1:on) Bit 1: Short-circuit recognition channel 1 (1:on) ... Bit 7: Short-circuit recognition channel 7 (1:on)

- Here you activate res. de-activate the Short-circuit recognition.

4.12.3 Diagnostic data

The following errors are listed in the diagnostics data:

- Error in project engineering / parameterization
- Wire-break
- Short-circuit
- Error external auxiliary supply

DS - Record set for access via CPU, PROFIBUS and PROFINET. The access happens by DS 01h. Additionally the first 4 bytes may be accessed by DS 00h.

IX - Index for access via CANopen. The access happens by IX 2F01h. Additionally the first 4 bytes may be accessed by IX 2F00h.

SX - Subindex (5005h) for access via EtherCAT.

More can be found in the according manual of your bus coupler.

Name	Bytes	Function	Default	DS	IX	SX
ERR_A	1	Diagnostic	00h	01h	2F01h	02h
MODTYP	1	Module information	1Fh			03h
RES2	1	reserved	00h			04h
ERR_D	1	Diagnostic	00h			05h
CHTYP	1	Channel type	72h			06h
NUMBIT	1	Number diagnostic bits per channel	08h			07h
NUMCH	1	Number of channels of a module	08h			08h
CHERR	1	Channel error	00h			09h

Name	Bytes	Function	Default	DS	IX	SX
CH0ERR	1	Channel-specific error channel 0	00h			0Ah
CH1ERR	1	Channel-specific error channel 1	00h			0Bh
...
CH7ERR	1	Channel-specific error channel 7	00h			11h
DIAG_US	4	µs ticker (32bit)	00h			13h

ERR_A Diagnostic

Byte	Bit 7 ... 0
0	Bit 0: set at module failure Bit 1: set at internal error Bit 2: set at external error Bit 3: set at channel error Bit 4: set at external auxiliary supply missing Bit 5, 6: reserved Bit 7: set at error in parameterization

MODTYP Module information

Byte	Bit 7 ... 0
0	Bit 3 ... 0: module class 1111b: Digital module Bit 4: set at channel information present Bit 7 ... 5: reserved

ERR_D Diagnostic

Byte	Bit 7 ... 0
0	Bit 3 ... 0: reserved Bit 4: set at internal communication error Bit 7 ... 5: reserved

CHTYP Channel type

Byte	Bit 7 ... 0
0	Bit 6 ... 0: channel type 72h: Digital output Bit 7: reserved

NUMBIT Diagnostic bits

Byte	Bit 7 ... 0
0	Number of diagnostic bits per channel (here 08h)

NUMCH Channels

Byte	Bit 7 ... 0
0	Number of channels of a module (here 08h)

CHERR Channel error

Byte	Bit 7 ... 0
0	Bit 0: set at error in channel 0 Bit 1: set at error in channel 1 ... Bit 7: set at error in channel 7

**CH0ERR CH1ERR
Channel specific**

Byte	Bit 7 ... 0
0	Channel-specific error channel x: Bit 0: set at configuring- / parameter assignment error Bit 1: reserved Bit 2: short-circuit to +DC 24V Bit 3: short-circuit to M Bit 4: set at wire-break Bit 7 ... 5: reserved

DIAG_US μ s ticker

Byte	Bit 7 ... 0
0...3	Value of the μ s ticker at the moment of the diagnostic

 μ s ticker

In the SLIO module there is a timer (μ s ticker). With PowerON the timer starts counting with 0. After $2^{32}-1\mu$ s the timer starts with 0 again.

4.13 022-1HB10 - DO 2xRelay**Properties**

The electronic module accepts binary control signals from the central bus system and transfers them to the process level via relay outputs. It has 2 channels that operate as switches and the status of each channel is monitored via LEDs.

- 2 relay outputs, isolated to the backplane bus
- DC 30V / AC 230V, 3A
- Status indication of the channels via LEDs

Structure

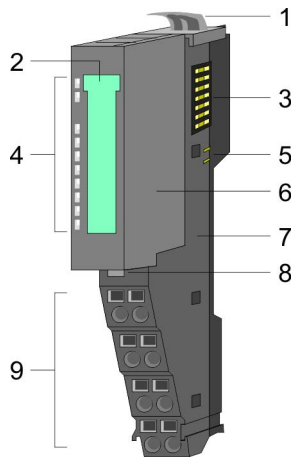

- 1 Locking lever terminal module
- 2 Labeling strip
- 3 Backplane bus
- 4 LED status indication
- 5 DC 24V power section supply
- 6 Electronic module
- 7 Terminal module
- 8 Locking lever electronic module
- 9 Terminal

Status indication

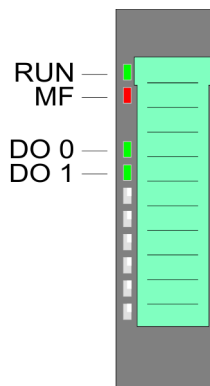

RUN	MF	DO x	Description
green	red	green	
■	■	■	
●	○	X	Bus communication is OK Module status is OK
●	●	X	Bus communication is OK Module status reports an error with over- load, short circuit or overheat
○	●	X	Bus communication is not possible Module status reports an error with over- load, short circuit or overheat
○	○	X	Error at bus power supply
X	B	X	Error in configuration ↪ <i>Chapter 2.7</i> <i>'Trouble shooting - LEDs' on page 28</i>
●	○	●	Relay output has "1" signal
●	○	○	Relay output has "0" signal
on: ● off: ○ blinks with 2Hz: B not relevant: X			



When using inductive load please take a suitable protector (see installation guidelines).

Pin assignment

For wires with a cross section of 0.08mm² up to 1.5mm².

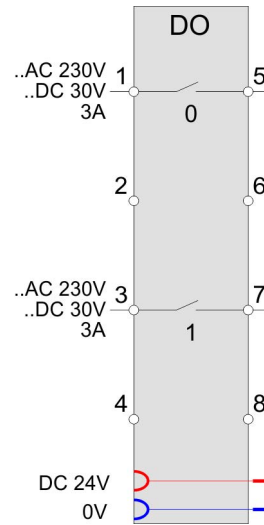
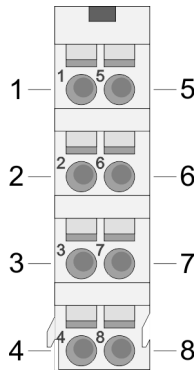

Pos.	Function	Type	Description
1	DO 0	O	Relay output DO 0
2	---	---	not connected
3	DO 1	O	Relay output DO 1
4	---	---	not connected
5	DO 0	O	Relay output DO 0
6	---	---	not connected
7	DO 1	O	Relay output DO 1
8	---	---	not connected

O: Output

Maximum load

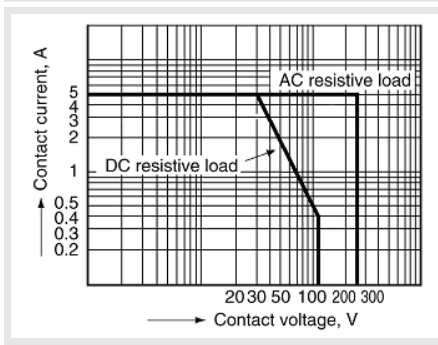

Service life

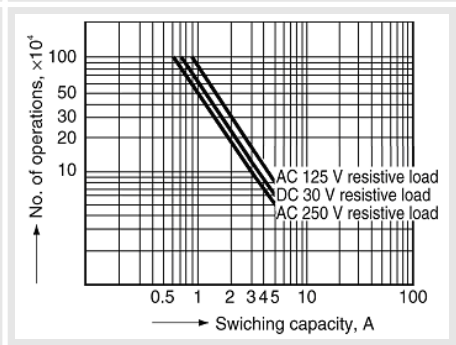

Input area

No byte of the input area is used by the module.

Output area

At CPU, PROFIBUS and PROFINET the output area is embedded to the corresponding address area.

IX - Index for access via CANopen

SX - Subindex (7000h + EtherCAT-Slot) for access via EtherCAT

More can be found in the according manual of your bus coupler.

Addr.	Name	Bytes	Function	IX	SX
+0	PIQ	1	State of the outputs	5200h	
			Bit 0: DO 0		01h
			Bit 1: DO 1		02h
			Bit 7 ... 2: reserved		

4.13.1 Technical data

Order no.	022-1HB10
Type	SM 022
Module ID	0109 AF90
Current consumption/power loss	
Current consumption from backplane bus	130 mA
Power loss	0.7 W
Technical data digital outputs	
Number of outputs	2
Cable length, shielded	1000 m
Cable length, unshielded	600 m
Rated load voltage	DC 30 V/ AC 230 V
Current consumption from load voltage L+ (without load)	-
Total current per group, horizontal configuration, 40°C	-
Total current per group, horizontal configuration, 60°C	-
Total current per group, vertical configuration	-
Output current at signal "1", rated value	3 A
Output delay of "0" to "1"	10 ms
Output delay of "1" to "0"	5 ms
Minimum load current	-
Lamp load	-
Parallel switching of outputs for redundant control of a load	-

Order no.	022-1HB10
Parallel switching of outputs for increased power	-
Actuation of digital input	-
Switching frequency with resistive load	max. 0.33 Hz
Switching frequency with inductive load	-
Switching frequency on lamp load	-
Internal limitation of inductive shut-off voltage	-
Short-circuit protection of output	-
Trigger level	-
Number of operating cycle of relay outputs	-
Switching capacity of contacts	3 A
Output data size	2 Bit
Status information, alarms, diagnostics	
Status display	green LED per channel
Interrupts	no
Process alarm	no
Diagnostic interrupt	no
Diagnostic functions	no
Diagnostics information read-out	none
Supply voltage display	green LED
Group error display	red LED
Channel error display	none
Isolation	
Between channels	✓
Between channels of groups to	-
Between channels and backplane bus	✓
Insulation tested with	DC 500 V
PWM data	
PWM channels	-
PWM time basis	-
Period length	-
Minimum pulse width	-
PtP communication	-
Safety	
Safety protocol	-
Safety requirements	-

Order no.	022-1HB10
Secure user address	-
Watchdog	-
Two channels	-
Test pulse length	-
Circuit monitoring	-
Datasizes	
Input bytes	0
Output bytes	1
Parameter bytes	0
Diagnostic bytes	0
Housing	
Material	PPE / PPE GF10
Mounting	Profile rail 35 mm
Mechanical data	
Dimensions (WxHxD)	12.9 mm x 109 mm x 76.5 mm
Weight	60 g
Environmental conditions	
Operating temperature	0 °C to 60 °C
Storage temperature	-25 °C to 70 °C
Certifications	
UL certification	yes