

System SLIO

IM | 053-1ML00 | Manual

HB300 | IM | 053-1ML00 | en | 22-30

Interface module MECHATROLINK-III - IM 053ML



VIPA USA, INC
980 Birmingham Rd. Ste 721
Alpharetta, GA 30004 USA

Tel.: +1 (678) 880-6910
Email: info@vipausa.com
Internet: www.vipausa.com

Table of contents

1	General	5
1.1	Copyright © YASKAWA Europe GmbH.....	5
1.2	About this manual.....	6
1.3	Safety information.....	6
2	Basics and mounting	8
2.1	Safety notes for the user.....	8
2.2	System conception.....	9
2.2.1	Overview.....	9
2.2.2	Components.....	10
2.2.3	Accessories.....	13
2.2.4	Hardware revision.....	15
2.3	Dimensions.....	15
2.4	Mounting bus coupler.....	18
2.5	Wiring.....	20
2.5.1	Wiring bus coupler.....	20
2.5.2	Wiring 8x periphery modules.....	23
2.5.3	Wiring 16x periphery modules.....	25
2.5.4	Wiring power modules.....	26
2.6	Demounting.....	30
2.6.1	Demounting bus coupler.....	30
2.6.2	Demounting 8x periphery modules.....	32
2.6.3	Demounting 16x periphery modules.....	35
2.7	Trouble shooting - LEDs.....	38
2.8	Industrial security and installation guidelines.....	39
2.8.1	Industrial security in information technology.....	39
2.8.2	Installation guidelines.....	41
2.9	General data for the System SLIO.....	43
2.9.1	Use in difficult operating conditions.....	45
3	Hardware description	46
3.1	Properties.....	46
3.2	Structure.....	47
3.2.1	Interfaces.....	47
3.2.2	LEDs.....	48
3.2.3	Address switch.....	50
3.3	Technical data.....	51
4	Deployment	54
4.1	Basics MECHATROLINK-III.....	54
4.2	MECHATROLINK-III installation guidelines.....	55
4.2.1	Topology.....	55
4.3	Accessing the System SLIO.....	57
4.3.1	Supported modules.....	57
4.3.2	Overview.....	59
4.3.3	Example.....	60
4.4	Communication with the MECHATROLINK-III master	61
4.5	I/O area of the IM 053ML.....	62
4.6	Web server.....	64
4.7	Virtual memory.....	67

4.8 Alarms and warnings.....	72
4.9 MECHATROLINK-III specification.....	75
4.9.1 Phases of the communication.....	75
4.9.2 Standard IO profile.....	77
4.9.3 ID information acquisition profile.....	82
4.9.4 Command detail.....	83
4.9.5 MECHATROLINK message communication sub functions.....	94
4.9.6 Command sequence.....	96
4.10 Sample application.....	97
4.10.1 Overview.....	97
4.10.2 Sequence of coupler commands.....	99
4.10.3 Communication structure.....	100
Appendix.....	101
A History of changes.....	103

1 General

1.1 Copyright © YASKAWA Europe GmbH

All Rights Reserved

This document contains proprietary information of Yaskawa and is not to be disclosed or used except in accordance with applicable agreements.

This material is protected by copyright laws. It may not be reproduced, distributed, or altered in any fashion by any entity (either internal or external to Yaskawa) except in accordance with applicable agreements, contracts or licensing, without the express written consent of Yaskawa and the business management owner of the material.

For permission to reproduce or distribute, please contact: YASKAWA Europe GmbH, European Headquarters, Hauptstraße 185, 65760 Eschborn, Germany

Tel.: +49 6196 569 300

Fax.: +49 6196 569 398

Email: info@yaskawa.eu.com

Internet: www.yaskawa.eu.com

EC conformity declaration

Hereby, YASKAWA Europe GmbH declares that the products and systems are in compliance with the essential requirements and other relevant provisions. Conformity is indicated by the CE marking affixed to the product.

Conformity Information

For more information regarding CE marking and Declaration of Conformity (DoC), please contact your local representative of YASKAWA Europe GmbH.

Trademarks

SLIO and SPEED7 are registered trademarks of YASKAWA Europe GmbH.

MECHATROLINK is a registered trademark of YASKAWA Corporation.

All other trademarks, logos and service or product marks specified herein are owned by their respective companies.

General terms of use

Every effort has been made to ensure that the information contained in this document was complete and accurate at the time of publishing. We cannot guarantee that the information is free of errors, and we reserve the right to change the information at any time. There is no obligation to inform the customer about any changes. The customer is requested to actively keep his documents up to date. The customer is always responsible for the deployment of the products with the associated documentation, taking into account the applicable directives and standards.

This documentation describes all hardware and software units and functions known today. It is possible that units are described that do not exist at the customer. The exact scope of delivery is described in the respective purchase contract.

Document support

Contact your local representative of YASKAWA Europe GmbH if you have errors or questions regarding the content of this document. You can reach YASKAWA Europe GmbH via the following contact:

Email: Documentation.HER@yaskawa.eu.com

Technical support

Contact your local representative of YASKAWA Europe GmbH if you encounter problems or have questions regarding the product. If such a location is not available, you can reach the Yaskawa customer service via the following contact:

YASKAWA Europe GmbH,

European Headquarters, Hauptstraße 185, 65760 Eschborn, Germany

Tel.: +49 6196 569 500 (hotline)

Email: support@yaskawa.eu.com

1.2 About this manual

Objective and contents

This manual describes the IM 053ML of the System SLIO.

- It describes the structure, configuration and application.
- The manual is targeted at users who have a background in automation technology.
- The manual consists of chapters. Each chapter describes a completed topic.
- For guidance, the manual provides:
 - An overall table of contents at the beginning of the manual.
 - References with pages numbers.

Validity of the documentation

Product	Order no.	as of state:	
IM 053ML	053-1ML00	HW: 01	FW: 1.0.5

Icons Headings

Important passages in the text are highlighted by following icons and headings:



DANGER!

Immediate or likely danger. Personal injury is possible.



CAUTION!

Damages to property is likely if these warnings are not heeded.



Supplementary information and useful tips.

1.3 Safety information

Applications conforming with specifications

The system is constructed and produced for:

- communication and process control
- general control and automation tasks
- industrial applications
- operation within the environmental conditions specified in the technical data
- installation into a cubicle



DANGER!

This device is not certified for applications in

- in explosive environments (EX-zone)

Documentation

The manual must be available to all personnel in the

- project design department
- installation department
- commissioning
- operation

**CAUTION!**

The following conditions must be met before using or commissioning the components described in this manual:

- Hardware modifications to the process control system should only be carried out when the system has been disconnected from power!
- Installation and hardware modifications only by properly trained personnel.
- The national rules and regulations of the respective country must be satisfied (installation, safety, EMC ...)

Disposal

National rules and regulations apply to the disposal of the unit!

2 Basics and mounting

2.1 Safety notes for the user



DANGER!

Protection against dangerous voltages

- When using System SLIO modules, the user must be protected from touching hazardous voltage.
- You must therefore create an insulation concept for your system that includes safe separation of the potential areas of ELV and hazardous voltage.
- Here, observe the insulation voltages between the potential areas specified for the System SLIO modules and take suitable measures, such as using PELV/SELV power supplies for System SLIO modules.

Handling of electrostatic sensitive modules

The modules are equipped with highly integrated components in MOS technology. These components are highly sensitive to over-voltages that occur, e.g. with electrostatic discharge. The following symbol is used to identify these hazardous modules:



The symbol is located on modules, module racks or on packaging and thus indicates electrostatic sensitive modules. Electrostatic sensitive modules can be destroyed by energies and voltages that are far below the limits of human perception. If a person who is not electrically discharged handles electrostatic sensitive modules, voltages can occur and damage components and thus impair the functionality of the modules or render the modules unusable. Modules damaged in this way are in most cases not immediately recognized as faulty. The error can only appear after a long period of operation. Components damaged by static discharge can show temporary faults when exposed to temperature changes, vibrations or load changes. Only the consistent use of protective devices and responsible observance of the handling rules can effectively prevent malfunctions and failures on electrostatic sensitive modules.

Shipping of modules

Please always use the original packaging for shipping.

Measurement and modification of electrostatic sensitive modules

For measurements on electrostatic sensitive modules the following must be observed:

- Floating measuring instruments must be discharged before use.
- Measuring instruments used must be grounded.

When modifying electrostatic sensitive modules, ensure that a grounded soldering iron is used.



CAUTION!

When working with and on electrostatic sensitive modules, make sure that personnel and equipment are adequately grounded.

2.2 System conception

2.2.1 Overview

The System SLIO is a modular automation system for assembly on a 35mm mounting rail. By means of the periphery modules with 2, 4, 8 and 16 channels this system may properly be adapted matching to your automation tasks. The wiring complexity is low, because the supply of the DC 24V power section supply is integrated to the backplane bus and defective modules may be replaced with standing wiring. By deployment of the power modules in contrasting colors within the system, further isolated areas may be defined for the DC 24V power section supply, respectively the electronic power supply may be extended with 2A.

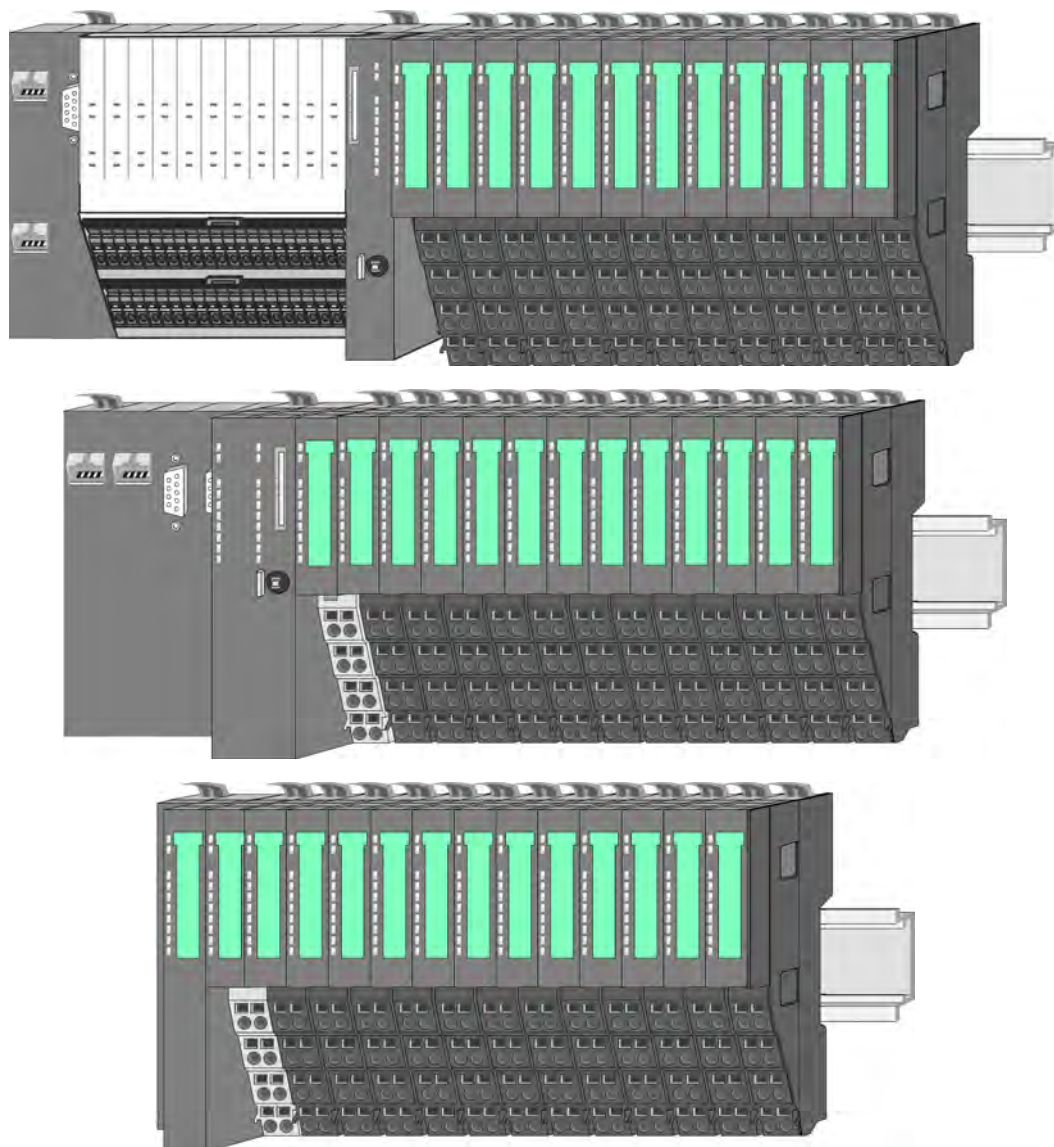

2.2.2 Components

- CPU (head module)
- Bus coupler (head module)
- Line extension
- 8x periphery modules
- 16x periphery modules
- Power modules
- Accessories



CAUTION!

Only Yaskawa modules may be combined. A mixed operation with third-party modules is not allowed!

CPU 01xC

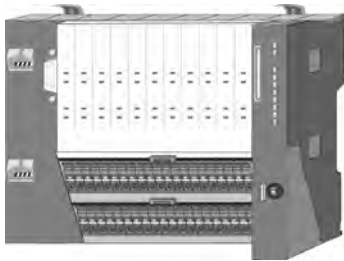

With the CPU 01xC electronic, input/output components and power supply are integrated to one casing. In addition, up to 64 periphery modules of the System SLIO can be connected to the backplane bus. As head module via the integrated power module for power supply CPU electronic and the I/O components are supplied as well as the electronic of the periphery modules, which are connected via backplane bus. To connect the power supply of the I/O components and for DC 24V power section supply of via backplane bus connected periphery modules, the CPU has removable connectors. By installing of up to 64 periphery modules at the backplane bus, these are electrically connected, this means these are assigned to the backplane bus, the electronic modules are power supplied and each periphery module is connected to the DC 24V power section supply.

CPU 01x



With this CPU 01x, CPU electronic and power supply are integrated to one casing. As head module, via the integrated power module for power supply, CPU electronic and the electronic of the connected periphery modules are supplied. The DC 24V power section supply for the linked periphery modules is established via a further connection of the power module. By installing of up to 64 periphery modules at the backplane bus, these are electrically connected, this means these are assigned to the backplane bus, the electronic modules are power supplied and each periphery module is connected to the DC 24V power section supply.



CAUTION!

CPU part and power module may not be separated!
Here you may only exchange the electronic module!

Bus coupler



With a bus coupler bus interface and power module is integrated to one casing. With the bus interface you get access to a subordinated bus system. As head module, via the integrated power module for power supply, bus interface and the electronic of the connected periphery modules are supplied. The DC 24V power section supply for the linked periphery modules is established via a further connection of the power module. By installing of up to 64 periphery modules at the bus coupler, these are electrically connected, this means these are assigned to the backplane bus, the electronic modules are power supplied and each periphery module is connected to the DC 24V power section supply.



CAUTION!

Bus interface and power module may not be separated!
Here you may only exchange the electronic module!

Line extension

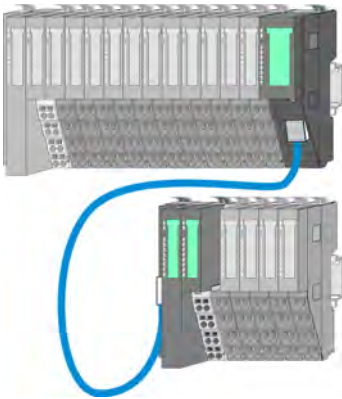

In the System SLIO there is the possibility to place up to 64 modules in on line. By means of the line extension you can divide this line into several lines. Here you have to place a line extension master at each end of a line and the subsequent line has to start with a line extension slave. Master and slave are to be connected via a special connecting cable. In this way, you can divide a line on up to 5 lines. For each line extension the maximum number of pluggable modules at the System SLIO bus is decreased by 1. To use the line extension no special configuration is required.



Please note that some modules do not support line extensions due to the system. For more information, see the 'System SLIO - Compatibility List' at www.yaskawa.eu.com

Periphery modules

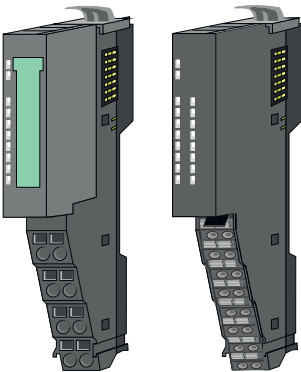

The periphery modules are available in the following 2 versions, whereby of each the electronic part can be replaced with standing wiring:

- 8x periphery module for a maximum of 8 channels.
- 16x periphery module for a maximum of 16 channels.

8x periphery modules

Each 8x periphery module consists of a *terminal* and an *electronic module*.

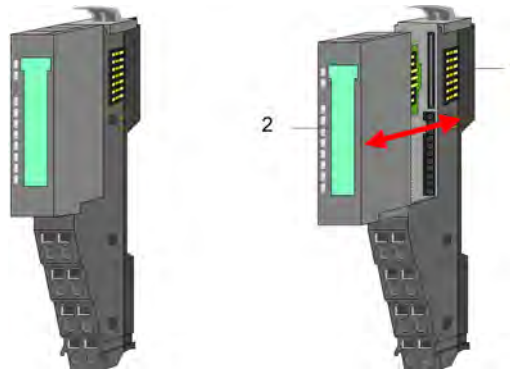

- 1 Terminal module
- 2 Electronic module

Terminal module



The *terminal* module serves to carry the electronic module, contains the backplane bus with power supply for the electronic, the DC 24V power section supply and the staircase-shaped terminal for wiring. Additionally the terminal module has a locking system for fixing at a mounting rail. By means of this locking system your system may be assembled outside of your switchgear cabinet to be later mounted there as whole system.

Electronic module



The functionality of a periphery module is defined by the *electronic module*, which is mounted to the terminal module by a sliding mechanism. With an error the defective electronic module may be exchanged for a functional module with standing installation. At the front side there are LEDs for status indication. For simple wiring each module shows corresponding connection information at the front and at the side.

16x periphery modules

Each 16x periphery module consists of an *electronic unit* and a *terminal block*.

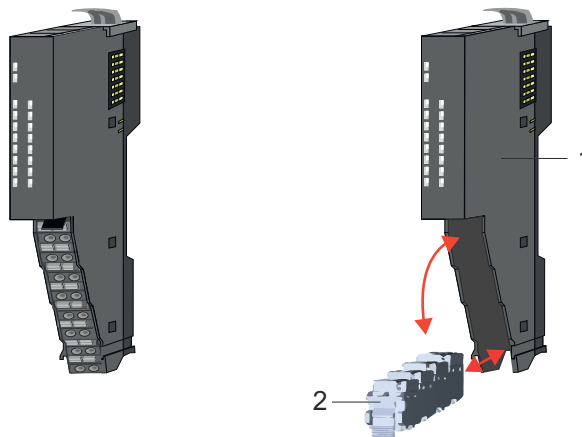

- 1 Electronic unit
- 2 Terminal block

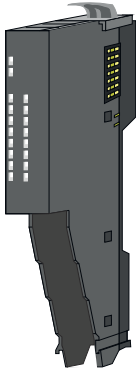
Electronic unit

The functionality of a 16x periphery module is defined via the terminal block, which is connected to the *electronic unit* via a secure flap mechanism. In the case of an error you can exchange the defective electronic unit for a functional unit with standing wiring. At the front side there are LEDs for status indication. For easy wiring each electronic unit shows corresponding connection information at the side. The electronic unit provides the slot for the terminal block for the wiring and contains the backplane bus with power supply for the electronic and the connection to the DC 24V power section supply. Additionally the electronic unit has a locking system for fixing it at a mounting rail. By means of this locking system your system may be assembled outside of your switchgear cabinet to be later mounted there as whole system.

Terminal block

The *terminal block* provides the electrical interface for the signalling and supplies lines of the module. When mounting the terminal block, it is attached to the bottom of the electronic unit and turned towards the electronic unit until it clicks into place. With the wiring a "push-in" spring-clip technique is used. This allows a quick and easy connection of your signal and supply lines. The clamping off takes place by means of a screwdriver.

Power module

In the System SLIO the power supply is established by power modules. These are either integrated to the head module or may be installed between the periphery modules. Depending on the power module isolated areas of the DC 24V power section supply may be defined respectively the electronic power supply may be extended with 2A. For better recognition the colour of the power modules are contrasting to the periphery modules.

2.2.3 Accessories**Shield bus carrier**

Please note that a shield bus carrier cannot be mounted on a 16x periphery module!



The shield bus carrier (order no.: 000-0AB00) serves to carry the shield bus (10mm x 3mm) to connect cable shields. Shield bus carriers, shield bus and shield fixings are not in the scope of delivery. They are only available as accessories. The shield bus carrier is mounted underneath the terminal of the terminal module. With a flat mounting rail for adaptation to a flat mounting rail you may remove the spacer of the shield bus carrier.

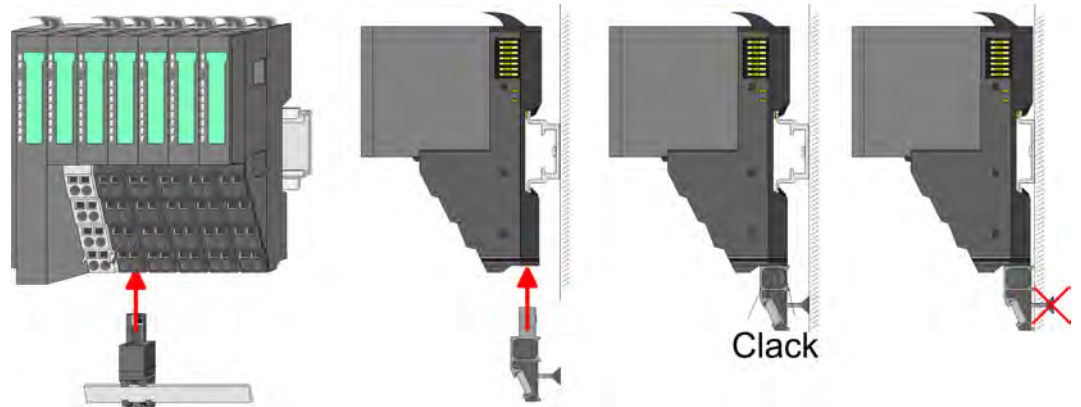

Bus cover

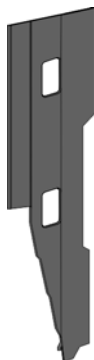

With each head module, to protect the backplane bus connectors, there is a mounted bus cover in the scope of delivery. You have to remove the bus cover of the head module before mounting a System SLIO module. For the protection of the backplane bus connector you always have to mount the bus cover at the last module of your system again. The bus cover has the order no. 000-0AA00.

Coding pins



Please note that a coding pin cannot be installed on a 16x periphery module! Here you have to make sure that the associated terminal block is plugged again when the electronics unit is replaced.

There is the possibility to fix the assignment of electronic and terminal module. Here coding pins (order number 000-0AC00) can be used. The coding pin consists of a coding jack and a coding plug. By combining electronic and terminal module with coding pin, the coding jack remains in the electronic module and the coding plug in the terminal module. This ensures that after replacing the electronic module just another electronic module can be plugged with the same encoding.

2.2.4 Hardware revision

Hardware revision on the front

- The hardware revision is printed on every System SLIO module.
- Since a System SLIO 8x peripheral module consists of a terminal and electronic module, you will find a hardware revision printed on each of them.
- Authoritative for the hardware revision of a System SLIO module is the hardware revision of the electronic module. This is located under the labeling strip of the corresponding electronic module.
- Depending on the module type, there are the following 2 variants e.g. to indicate hardware revision 1:
 - Current modules have a 1 on the front.
 - With earlier modules, the 1 is marked with 'X' on a number grid.

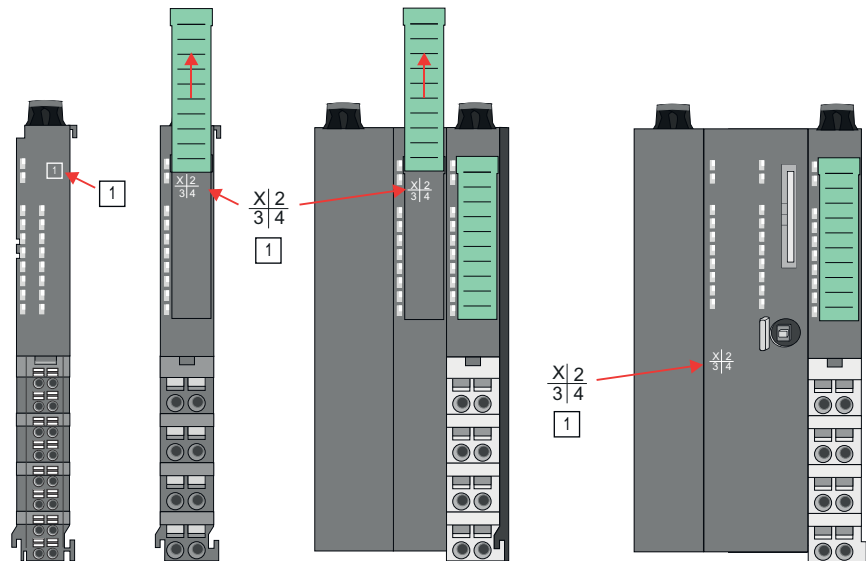

Hardware revision via web server

On the CPUs and some bus couplers, you can check the hardware revision 'HW Revision' via the integrated web server.

2.3 Dimensions

CPU 01xC

All dimensions are in mm.

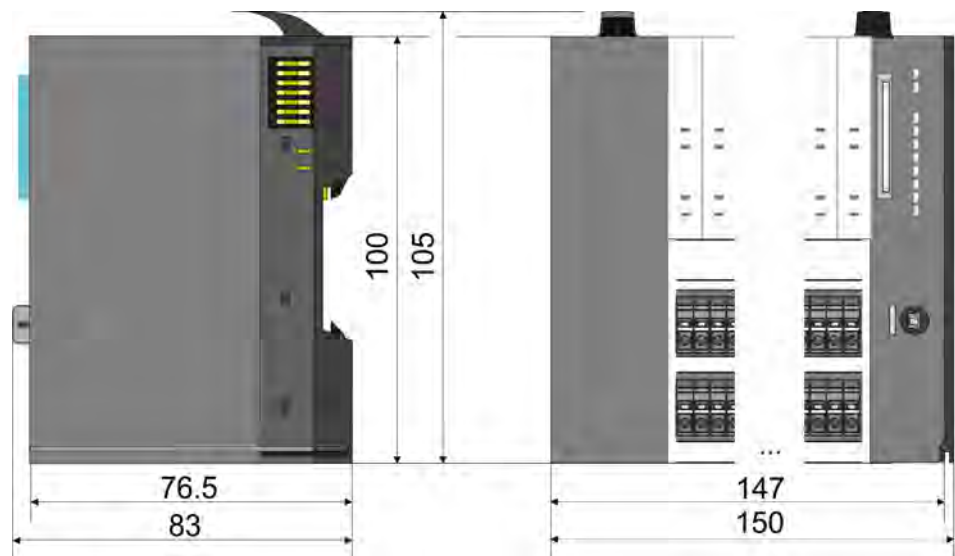

Dimensions

CPU 01x



Bus coupler and line extension slave

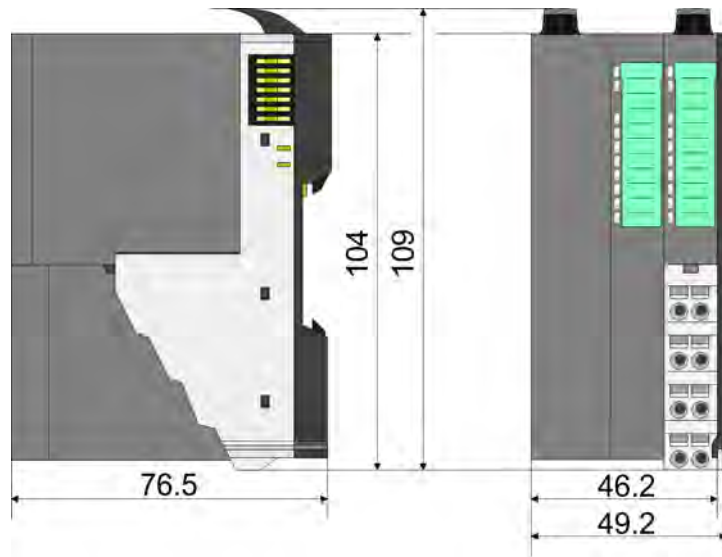

Line extension master

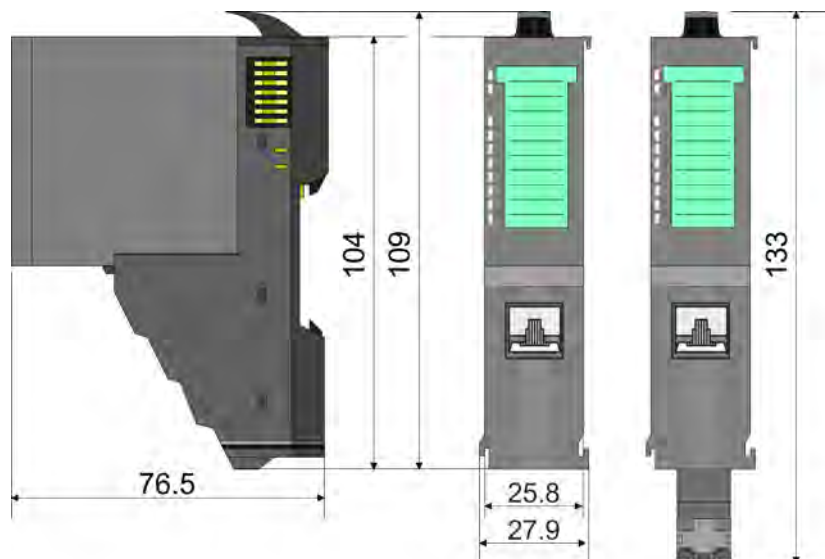

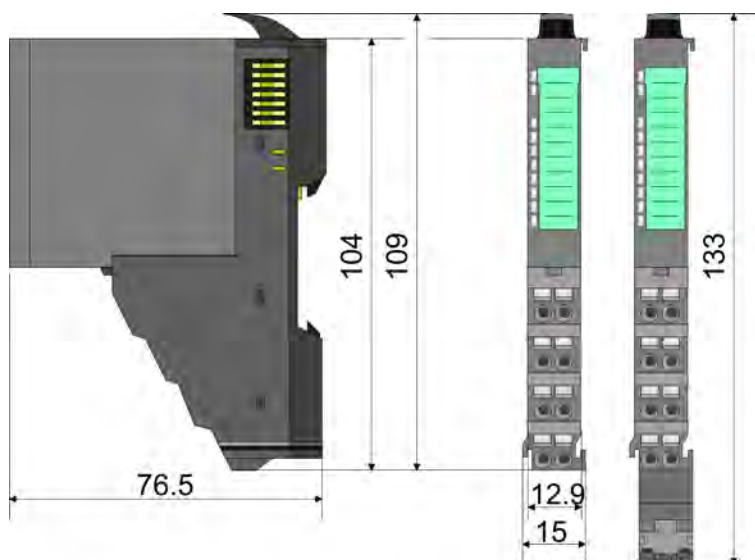
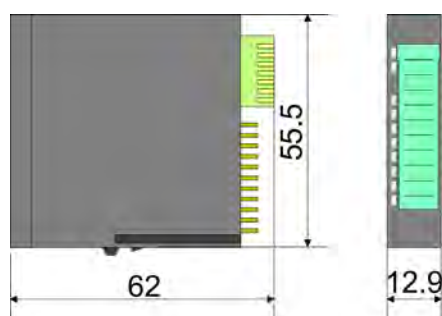
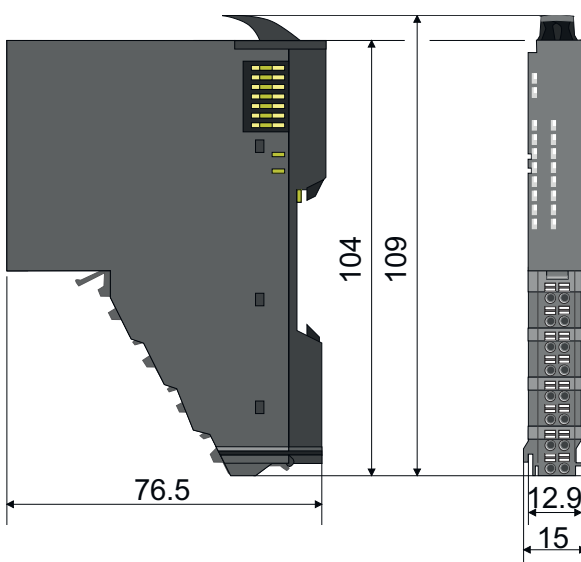
8x periphery module**Electronic module****16x periphery module**

2.4 Mounting bus coupler



CAUTION!

Requirements for UL compliance use

- Use for power supply exclusively SELV/PELV power supplies.
- The System SLIO must be installed and operated in a housing according to IEC 61010-1 9.3.2 c).

There are locking lever at the top side of the bus coupler. For mounting and demounting these locking lever are to be turned upwards until these engage. Place the bus coupler at the mounting rail. The bus coupler is fixed to the mounting rail by pushing downward the locking levers. The bus coupler is directly mounted at a mounting rail. Up to 64 modules may be mounted. The electronic and power section supply are connected via the back-plane bus. Please consider here that the sum current of the electronic power supply does not exceed the maximum value of 3A. By means of the power module 007-1AB10 the current of the electronic power supply may be expanded accordingly.

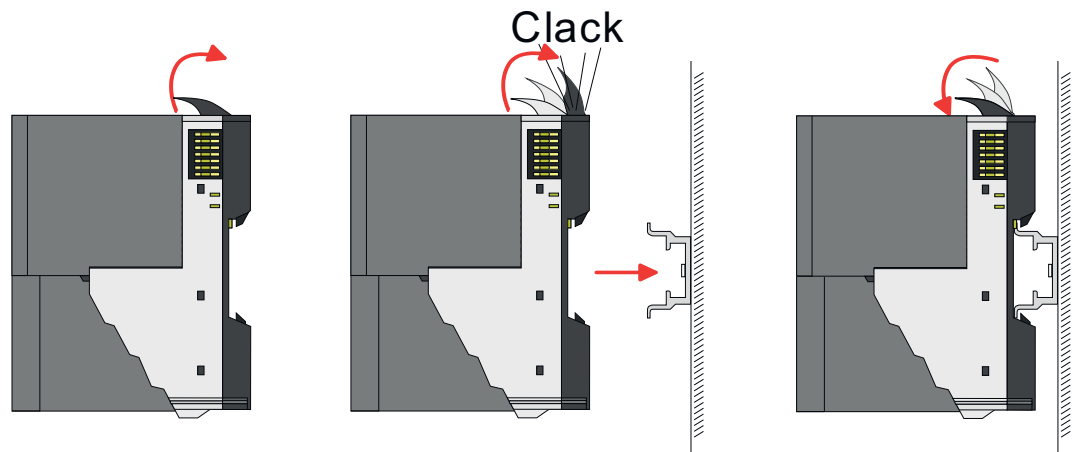

Proceeding

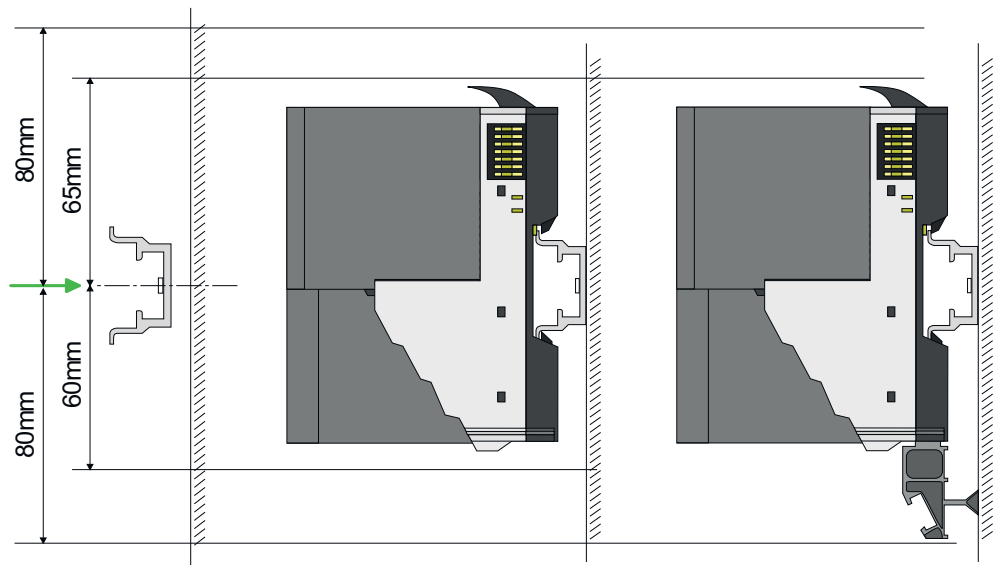

1. ➔ Mount the mounting rail! Please consider that a clearance from the middle of the mounting rail of at least 80mm above and 60mm below, respectively 80mm by deployment of shield bus carriers, exist.

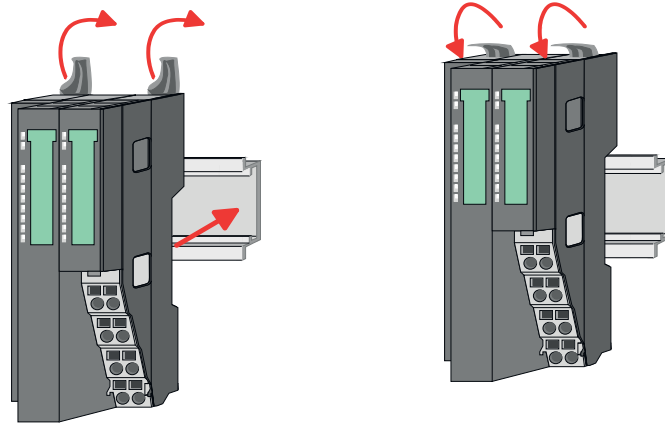

2. Turn the locking lever upwards, place the bus coupler at the mounting rail and turn the lever downward.

Mounting peripheral modules

The procedure is identical for 8x and 16x peripheral modules.

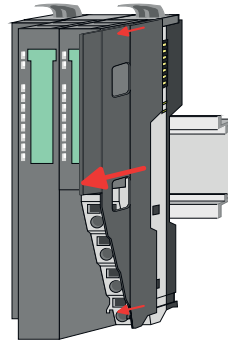

1. Before mounting the peripheral modules you have to remove the bus cover at the right side of the bus coupler by pulling it forward. Keep the cover for later mounting.

Clack

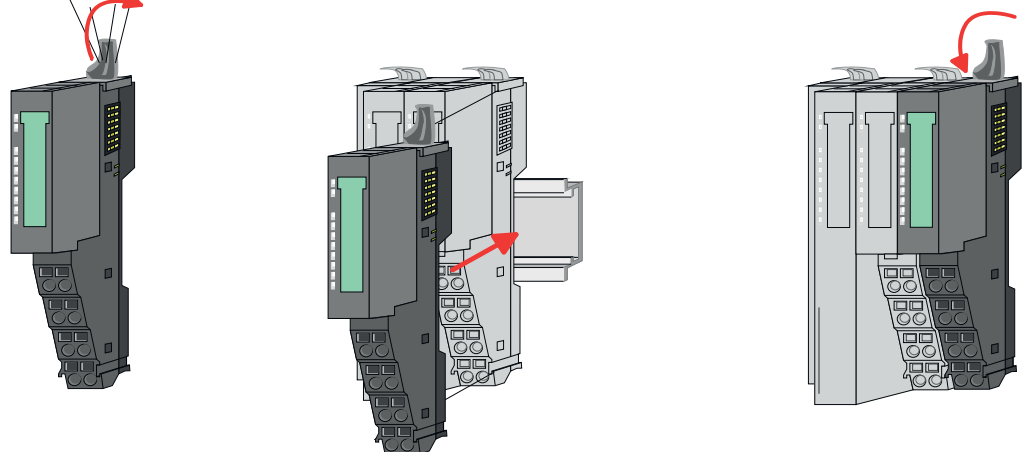

2. Mount the peripheral modules you want.

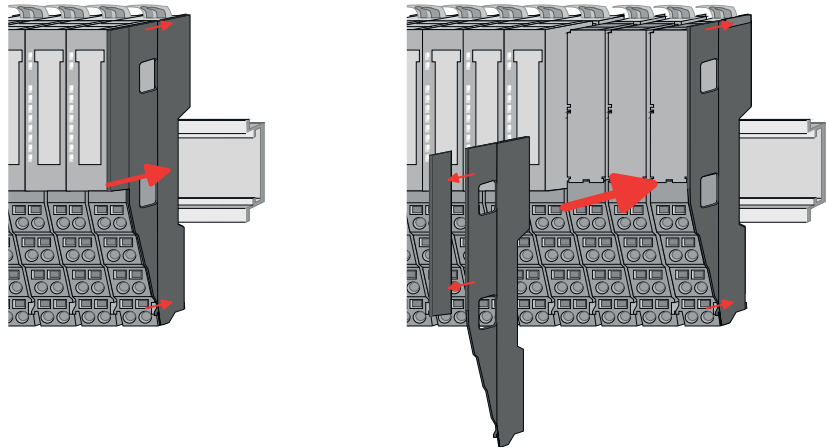

3. After mounting the whole system, to protect the backplane bus connectors at the last module you have to mount the bus cover, now. If the last module is a clamp module, for adaptation the upper part of the bus cover is to be removed.

2.5 Wiring



CAUTION!

Consider temperature for external cables!

Cables may experience temperature increase due to system heat dissipation. Thus the cabling specification must be chosen 5°C above ambient temperature!



CAUTION!

Separate insulation areas!

The system is specified for SELV/PELV environment. Devices, which are attached to the system must meet these specifications. Installation and cable routing other than SELV/PELV specification must be separated from the system's equipment!

2.5.1 Wiring bus coupler

Terminal module terminals

The System SLIO bus coupler have a power module integrated. Terminals with spring clamp technology are used for wiring. The spring clamp technology allows quick and easy connection of your signal and supply lines. In contrast to screw terminal connections this type of connection is vibration proof.

Data

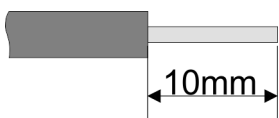

U_{max}	30V DC
I_{max}	10A
Cross section	0.08 ... 1.5mm ² (AWG 28 ... 16)
Stripping length	10mm

Wiring procedure



- 1 Pin number at the connector
- 2 Opening for screwdriver
- 3 Connection hole for wire

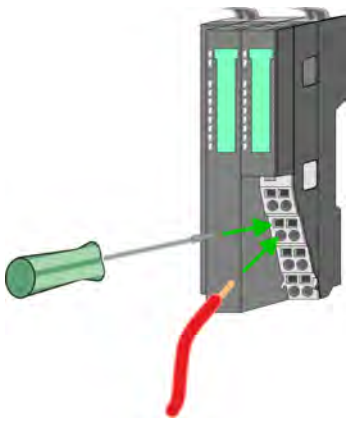
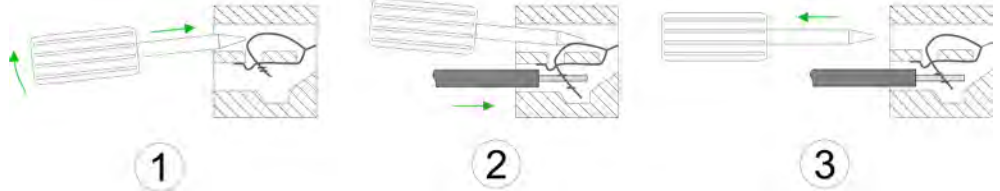

- 1. Insert a suited screwdriver at an angle into the square opening as shown. Press and hold the screwdriver in the opposite direction to open the contact spring.
- 2. Insert the stripped end of wire into the round opening. You can use wires with a cross section of 0.08mm² up to 1.5mm²
- 3. By removing the screwdriver, the wire is securely fixed via the spring contact to the terminal.

Standard wiring

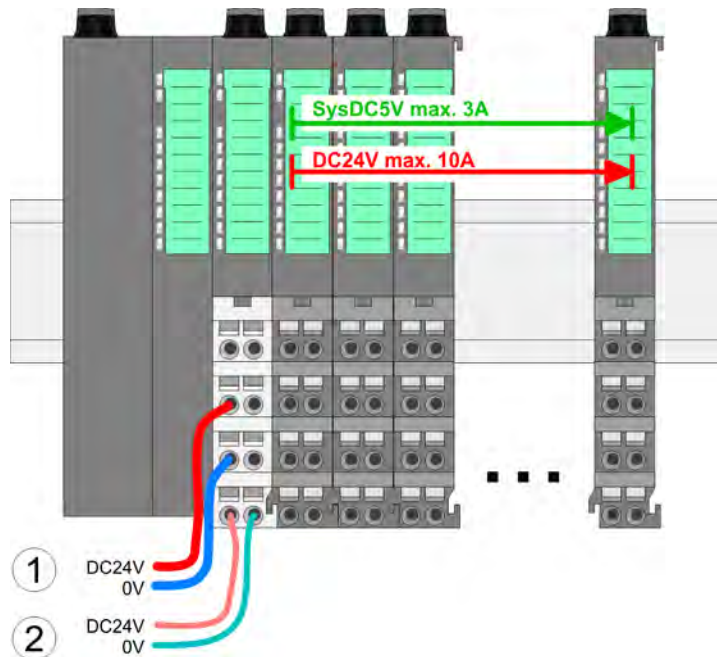

- (1) DC 24V for power section supply I/O area (max. 10A)
- (2) DC 24V for electronic power supply bus coupler and I/O area

PM - Power module

For wires with a core cross-section of 0.08mm² up to 1.5mm².

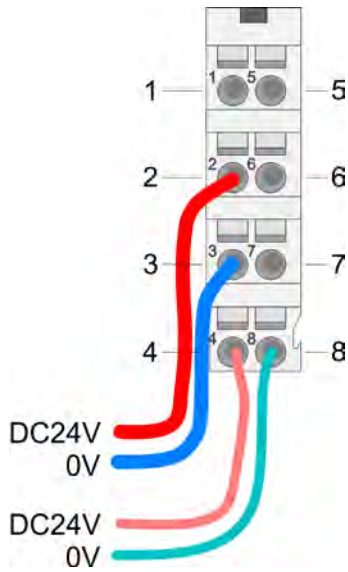

Pos.	Function	Type	Description
1	---	---	not connected
2	DC 24V	I	DC 24V for power section supply
3	0V	I	GND for power section supply
4	Sys DC 24V	I	DC 24V for electronic section supply
5	---	---	not connected
6	DC 24V	I	DC 24V for power section supply
7	0V	I	GND for power section supply
8	Sys 0V	I	GND for electronic section supply

I: Input



CAUTION!

Since the power section supply is not internally protected, it is to be externally protected with a fuse, which corresponds to the maximum current. This means max. 10A is to be protected by a 10A fuse (fast) respectively by a line circuit breaker 10A characteristics Z!



The electronic power section supply is internally protected against higher voltage by fuse. The fuse is within the power module. If the fuse releases, its electronic module must be exchanged!

Fusing

- The power section supply is to be externally protected with a fuse, which corresponds to the maximum current. This means max. 10A is to be protected with a 10A fuse (fast) respectively by a line circuit breaker 10A characteristics Z!
- It is recommended to externally protect the electronic power supply for bus coupler and I/O area with a 2A fuse (fast) respectively by a line circuit breaker 2A characteristics Z.
- The electronic power supply for the I/O area of the power module 007-1AB10 should also be externally protected with a 1A fuse (fast) respectively by a line circuit breaker 1A characteristics Z.

State of the electronic power supply via LEDs

After PowerON of the System SLIO the LEDs RUN respectively MF get on so far as the sum current does not exceed 3A. With a sum current greater than 3A the LEDs may not be activated. Here the power module with the order number 007-1AB10 is to be placed between the peripheral modules.

Shield attachment

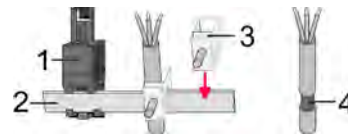

- 1 Shield bus carrier
- 2 Shield bus (10mm x 3mm)
- 3 Shield clamp
- 4 Cable shield

To attach the shield the mounting of shield bus carriers are necessary. The shield bus carrier (available as accessory) serves to carry the shield bus to connect cable shields.

1. ➤ Each System SLIO module has a carrier hole for the shield bus carrier. Push the shield bus carrier, until they engage into the module. With a flat mounting rail for adaptation to a flat mounting rail you may remove the spacer of the shield bus carrier.
2. ➤ Put your shield bus into the shield bus carrier.

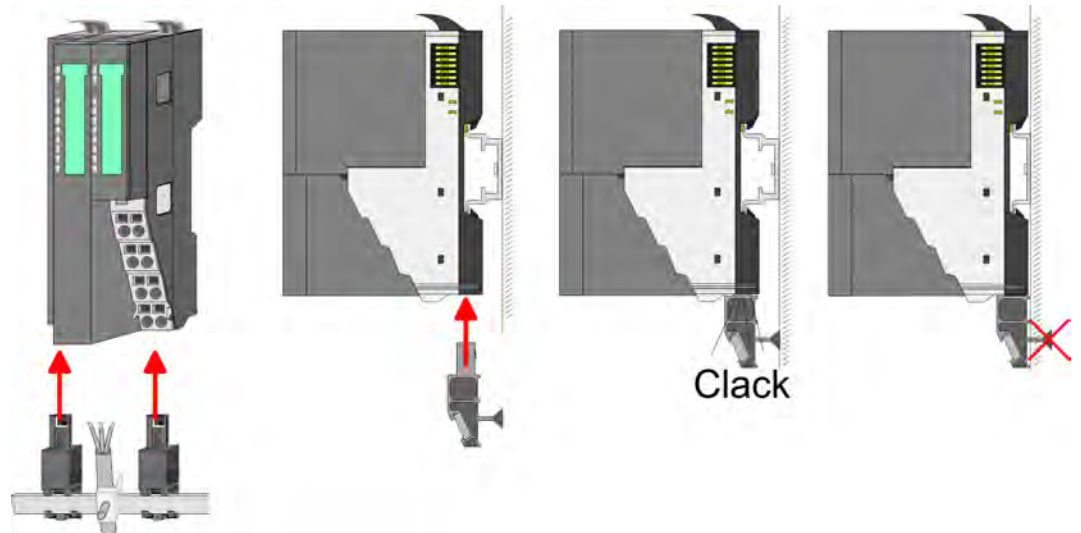

3. ➤ Attach the cables with the accordingly stripped cable screen and fix it by the shield clamp with the shield bus.

2.5.2 Wiring 8x periphery modules

Terminal module terminals

**CAUTION!****Do not connect hazardous voltages!**

If this is not explicitly stated in the corresponding module description, hazardous voltages are not allowed to be connected to the corresponding terminal module!

- With wiring the terminal modules, terminals with spring clamp technology are used for wiring. The spring clamp technology allows quick and easy connection of your signal and supply lines. In contrast to screw terminal connections this type of connection is vibration proof.

Data

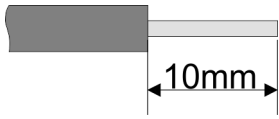

U_{max} 240V AC / 30V DC
 I_{max} 10A
 Cross section 0.08 ... 1.5mm² (AWG 28 ... 16)
 Stripping length 10mm

Wiring procedure



- 1 Pin number at the connector
- 2 Opening for screwdriver
- 3 Connection hole for wire

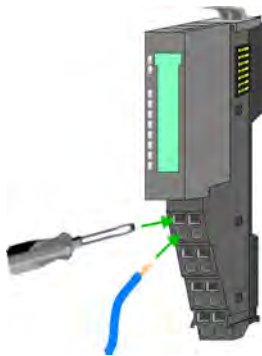
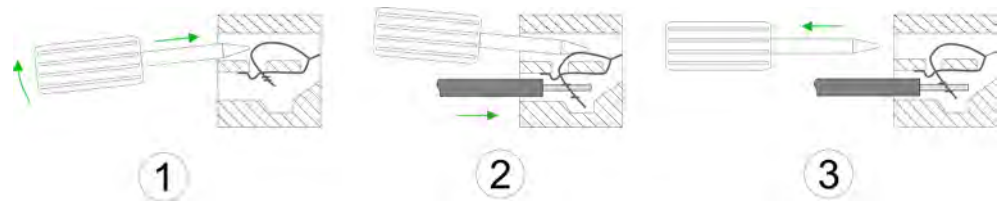

1. Insert a suited screwdriver at an angle into the square opening as shown. Press and hold the screwdriver in the opposite direction to open the contact spring.
2. Insert the stripped end of wire into the round opening. You can use wires with a cross section of 0.08mm² up to 1.5mm²
3. By removing the screwdriver, the wire is securely fixed via the spring contact to the terminal.

Shield attachment

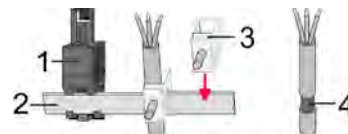

- 1 Shield bus carrier
- 2 Shield bus (10mm x 3mm)
- 3 Shield clamp
- 4 Cable shield

To attach the shield the mounting of shield bus carriers are necessary. The shield bus carrier (available as accessory) serves to carry the shield bus to connect cable shields.

1. Each System SLIO 8x periphery module has a carrier hole for the shield bus carrier. Push the shield bus carrier, until they engage into the module. With a flat mounting rail for adaptation to a flat mounting rail you may remove the spacer of the shield bus carrier.
2. Put your shield bus into the shield bus carrier.

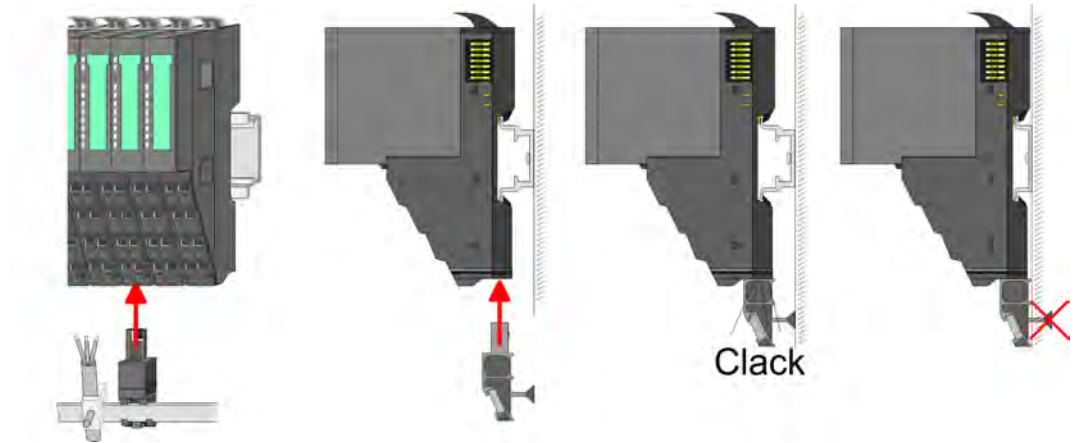

3. Attach the cables with the accordingly stripped cable screen and fix it by the shield clamp with the shield bus.

2.5.3 Wiring 16x periphery modules

Terminal block connectors



CAUTION!

Do not connect hazardous voltages!

If this is not explicitly stated in the corresponding module description, hazardous voltages are not allowed to be connected to the corresponding terminal block!

- The 16x periphery module has a removable terminal block for wiring.
- With the wiring of the terminal block a "push-in" spring-clip technique is used. This allows a quick and easy connection of your signal and supply lines.
- The clamping off takes place by means of a screwdriver.
- Please use copper wire only!

Data

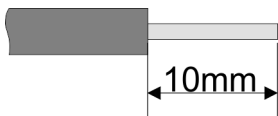

U_{max}	30V DC
I_{max}	10A
Cross section solid wire	0.25 ... 0.75mm ²
Cross section with ferrule	0.14 ... 0.75mm ²
Wire type	CU
AWG	24 ... 16
Stripping length	10mm

Wiring procedure



- 1 Release area
- 2 Connection hole for wire

Insert wire

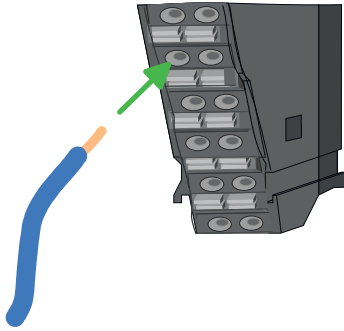

The wiring happens without a tool.

1. Determine according to the casing labelling the connection position.
2. Insert through the round connection hole of the according contact your prepared wire until it stops, so that it is fixed.
 - ⇒ By pushing the contact spring opens, thus ensuring the necessary contact pressure.

Remove wire

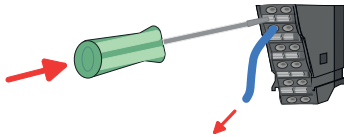

The wire is to be removed by means of a screwdriver with 2.5mm blade width.

1. Press with your screwdriver vertically at the release button.
 - ⇒ The contact spring releases the wire.
2. Pull the wire from the round hole.

2.5.4 Wiring power modules

Terminal module terminals

Power modules are either integrated to the head module or may be installed between the periphery modules. With power modules, terminals with spring clamp technology are used for wiring. The spring clamp technology allows quick and easy connection of your signal and supply lines. In contrast to screw terminal connections this type of connection is vibration proof.

Data

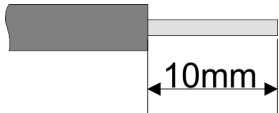

U_{max}	30V DC
I_{max}	10A
Cross section	0.08 ... 1.5mm ² (AWG 28 ... 16)
Stripping length	10mm

Wiring procedure



- 1 Pin number at the connector
- 2 Opening for screwdriver
- 3 Connection hole for wire

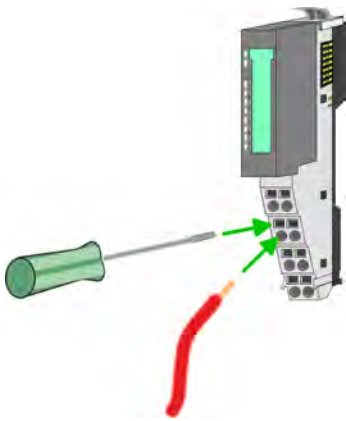
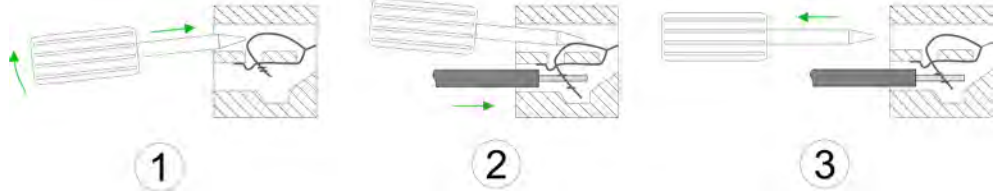

- 1. Insert a suited screwdriver at an angle into the square opening as shown. Press and hold the screwdriver in the opposite direction to open the contact spring.
- 2. Insert the stripped end of wire into the round opening. You can use wires with a cross section of 0.08mm² up to 1.5mm²
- 3. By removing the screwdriver, the wire is securely fixed via the spring contact to the terminal.

Standard wiring

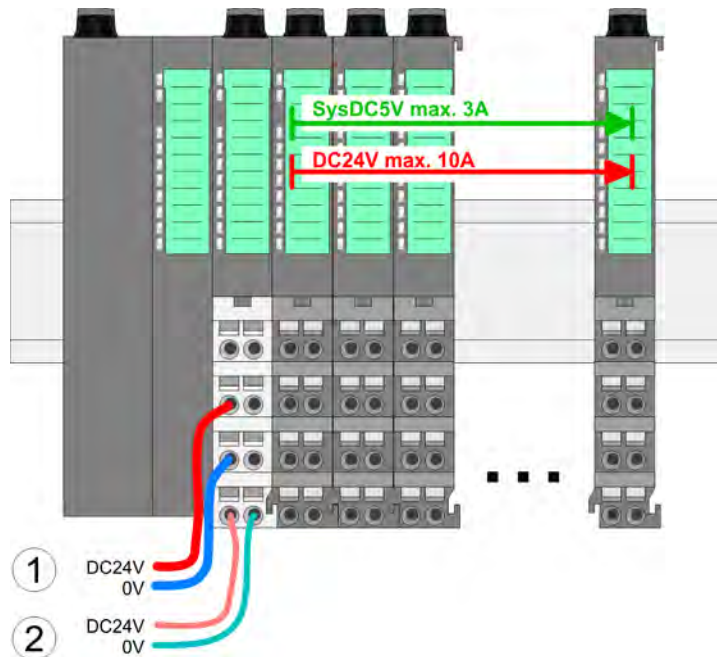

- (1) DC 24V for power section supply I/O area (max. 10A)
- (2) DC 24V for electronic power supply bus coupler and I/O area

PM - Power module

For wires with a core cross-section of 0.08mm² up to 1.5mm².

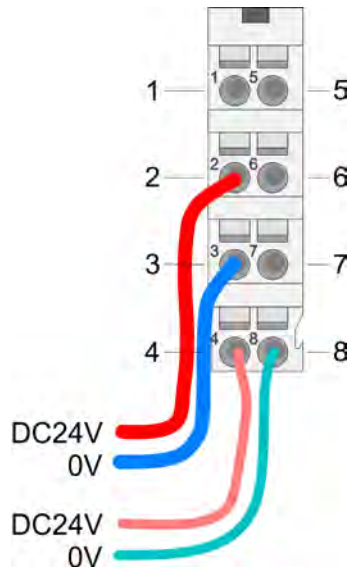

Pos.	Function	Type	Description
1	---	---	not connected
2	DC 24V	I	DC 24V for power section supply
3	0V	I	GND for power section supply
4	Sys DC 24V	I	DC 24V for electronic section supply
5	---	---	not connected
6	DC 24V	I	DC 24V for power section supply
7	0V	I	GND for power section supply
8	Sys 0V	I	GND for electronic section supply

I: Input



CAUTION!

Since the power section supply is not internally protected, it is to be externally protected with a fuse, which corresponds to the maximum current. This means max. 10A is to be protected by a 10A fuse (fast) respectively by a line circuit breaker 10A characteristics Z!



The electronic power section supply is internally protected against higher voltage by fuse. The fuse is within the power module. If the fuse releases, its electronic module must be exchanged!

Fusing

- The power section supply is to be externally protected with a fuse, which corresponds to the maximum current. This means max. 10A is to be protected with a 10A fuse (fast) respectively by a line circuit breaker 10A characteristics Z!
- It is recommended to externally protect the electronic power supply for head modules and I/O area with a 2A fuse (fast) respectively by a line circuit breaker 2A characteristics Z.
- The electronic power supply for the I/O area of the power module 007-1AB10 should also be externally protected with a 1A fuse (fast) respectively by a line circuit breaker 1A characteristics Z.

State of the electronic power supply via LEDs

After PowerON of the System SLIO the LEDs RUN respectively MF get on so far as the sum current does not exceed 3A. With a sum current greater than 3A the LEDs may not be activated. Here the power module with the order number 007-1AB10 is to be placed between the peripheral modules.

Deployment of the power modules

- If the 10A for the power section supply is no longer sufficient, you may use the power module with the order number 007-1AB00. So you have also the possibility to define isolated groups.
- The power module with the order number 007-1AB10 is to be used if the 3A for the electronic power supply at the backplane bus is no longer sufficient. Additionally you get an isolated group for the DC 24V power section supply with max. 4A.
- By placing the power module 007-1AB10 at the following backplane bus modules may be placed with a sum current of max. 2A. Afterwards a power module is to be placed again. To secure the power supply, the power modules may be mixed used.

Power module 007-1AB00

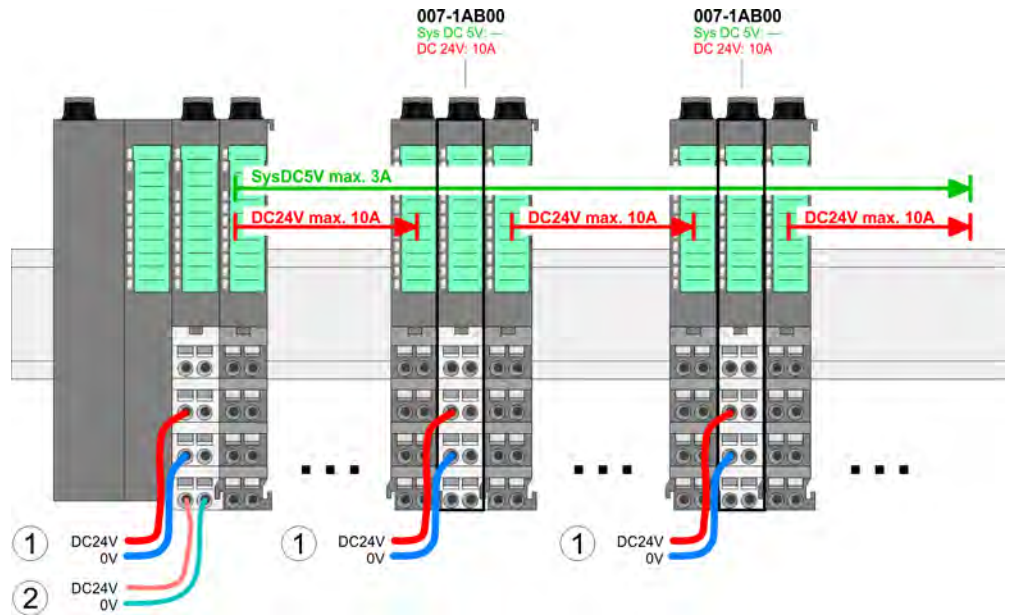

Power module 007-1AB10

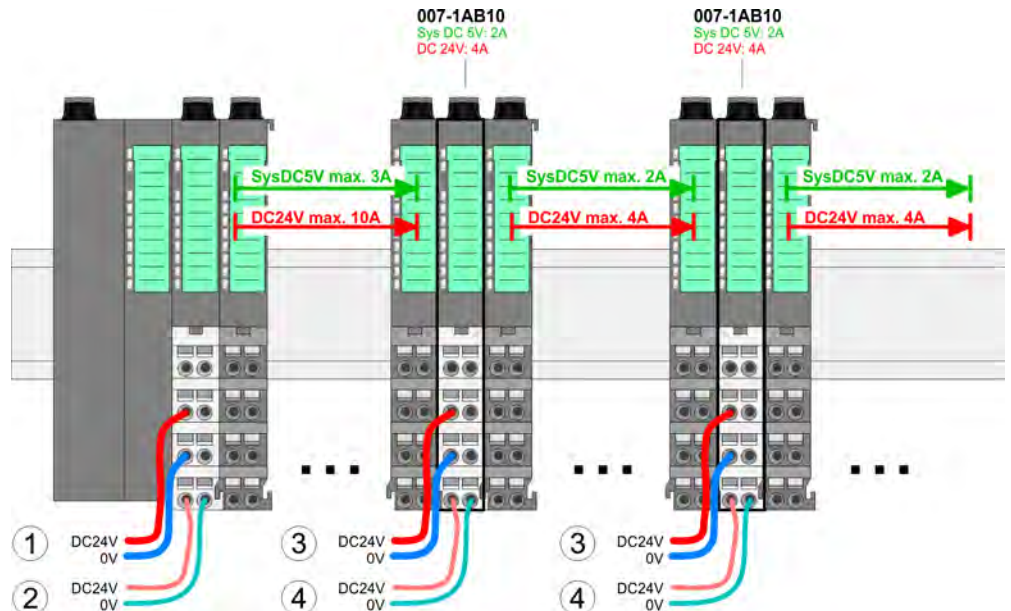

- (1) DC 24V for power section supply I/O area (max. 10A)
- (2) DC 24V for electronic power supply bus coupler and I/O area
- (3) DC 24V for power section supply I/O area (max. 4A)
- (4) DC 24V for electronic power supply I/O area

Shield attachment

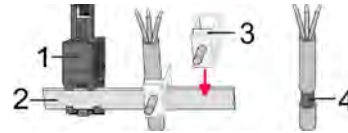

- 1 Shield bus carrier
- 2 Shield bus (10mm x 3mm)
- 3 Shield clamp
- 4 Cable shield

To attach the shield the mounting of shield bus carriers are necessary. The shield bus carrier (available as accessory) serves to carry the shield bus to connect cable shields.

- 1. Each System SLIO 8x peripheral module has a carrier hole for the shield bus carrier. Push the shield bus carrier, until they engage into the module. With a flat mounting rail for adaptation to a flat mounting rail you may remove the spacer of the shield bus carrier.
- 2. Put your shield bus into the shield bus carrier.

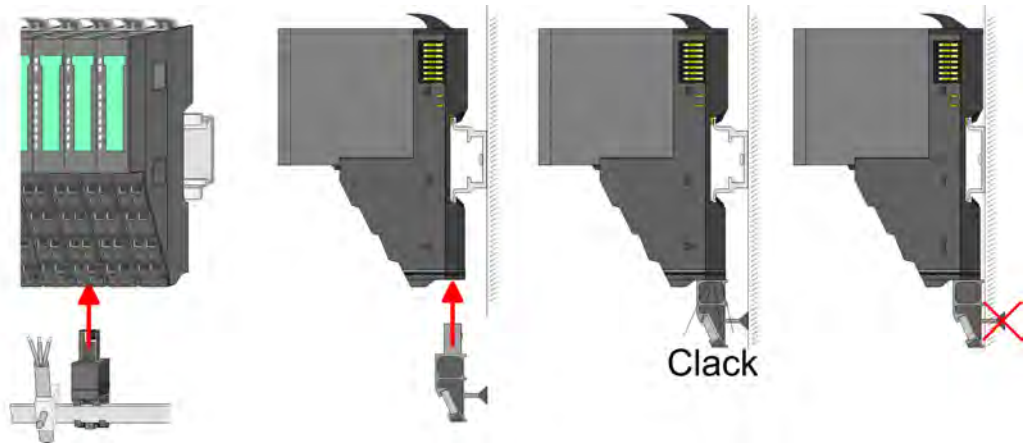

- 3. Attach the cables with the accordingly stripped cable screen and fix it by the shield clamp with the shield bus.

2.6 Demounting

2.6.1 Demounting bus coupler

Proceeding



CAUTION!

Bus interface and power module may not be separated! Here you may only exchange the electronic module!

- 1. Power-off your system.
- 2. Remove if exists the wiring of the bus coupler.
- 3.



For demounting and exchange of a (head) module or a group of modules, due to mounting reasons you always have to remove the electronic module right beside. After mounting it may be plugged again.

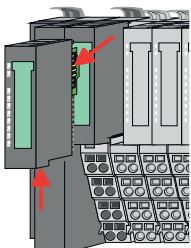

Press the unlocking lever at the lower side of the just mounted right module near the bus coupler and pull it forward.

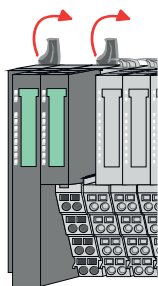

4. Turn all the locking lever of the bus coupler to be exchanged upwards.

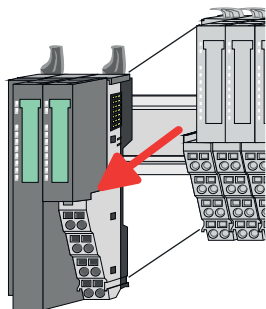

5. Pull the bus coupler forward.

6. For mounting turn all the locking lever of the bus coupler to be exchanged upwards.

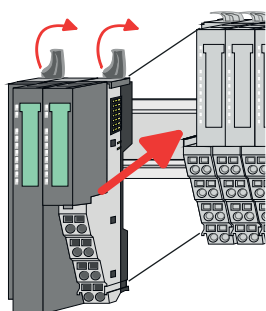

7. To mount the bus coupler put it to the left periphery module and push it, guided by the stripes, to the mounting rail.

8. Turn all the locking lever downward, again.

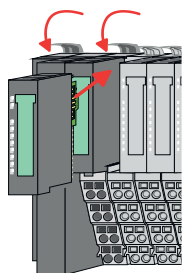

9. Plug again the electronic module, which you have removed before.

10. Wire your bus coupler.

⇒ Now you can bring your system back into operation.

2.6.2 Demounting 8x periphery modules

Proceeding

Exchange of an electronic module

1. ➤ Power-off your system.

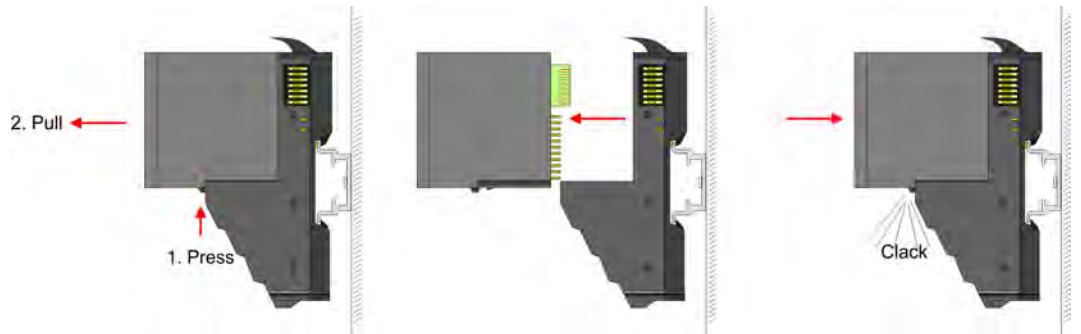

2. ➤ For the exchange of a electronic module, the electronic module may be pulled forward after pressing the unlocking lever at the lower side of the module.
3. ➤ For installation plug the new electronic module guided by the strips at the lower side until this engages to the terminal module.
 - ⇒ Now you can bring your system back into operation.



Easy Maintenance

'Easy Maintenance' means the support for adding and removing electronic modules during operation without having to restart the system. If this is supported by your head module, you will find more detailed information on this in the "Deployment" chapter.

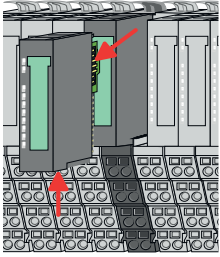
Exchange of a periphery module

1. ➤ Power-off your system.
2. ➤ Remove if exists the wiring of the module.
3. ➤



For demounting and exchange of a (head) module or a group of modules, due to mounting reasons you always have to remove the electronic module right beside. After mounting it may be plugged again.

Press the unlocking lever at the lower side of the just mounted right module and pull it forward.

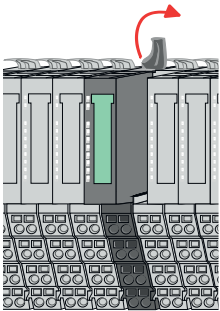

4. ➤ Turn the locking lever of the module to be exchanged upwards.

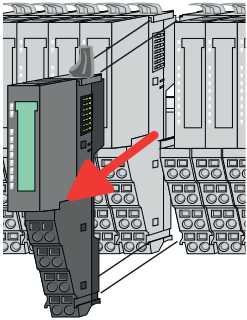

5. ➤ Pull the module.
6. ➤ For mounting turn the locking lever of the module to be mounted upwards.

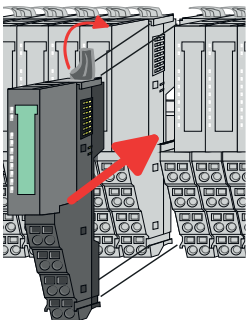

7. ➤ To mount the module put it to the gap between the both modules and push it, guided by the stripes at both sides, to the mounting rail.
8. ➤ Turn the locking lever downward, again.

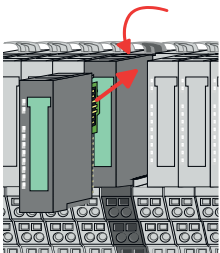

9. ➤ Plug again the electronic module, which you have removed before.
10. ➤ Wire your module.
 - ⇒ Now you can bring your system back into operation.

Exchange of a module group

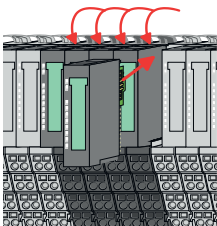
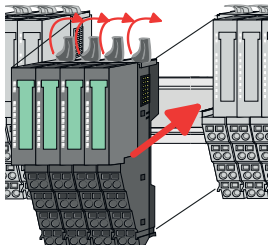
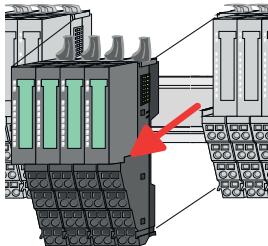
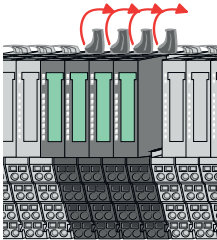
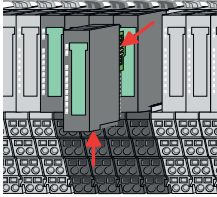

1. ➤ Power-off your system.
2. ➤ Remove if exists the wiring of the module group.

3. ➤

i For demounting and exchange of a (head) module or a group of modules, due to mounting reasons you always have to remove the electronic module *right beside*. After mounting it may be plugged again.

Press the unlocking lever at the lower side of the just mounted right module near the module group and pull it forward.

4. ➤ Turn all the locking lever of the module group to be exchanged upwards.

5. ➤ Pull the module group forward.

6. ➤ For mounting turn all the locking lever of the module group to be mounted upwards.

7. ➤ To mount the module group put it to the gap between the both modules and push it, guided by the stripes at both sides, to the mounting rail.

8. ➤ Turn all the locking lever downward, again.

9. ➤ Plug again the electronic module, which you have removed before.

10. ➤ Wire your module group.

⇒ Now you can bring your system back into operation.

2.6.3 Demounting 16x periphery modules

Proceeding

Exchange of an electronic unit

1. ➤ Power-off your system.
2. ➤ To replace an electronic unit, you can push down and pull off the terminal block after releasing the lock.

To mount the terminal block, place it horizontally on the lower side of the electronic unit and push it towards the electronic unit until it clicks into place.

⇒ Now you can bring your system back into operation.

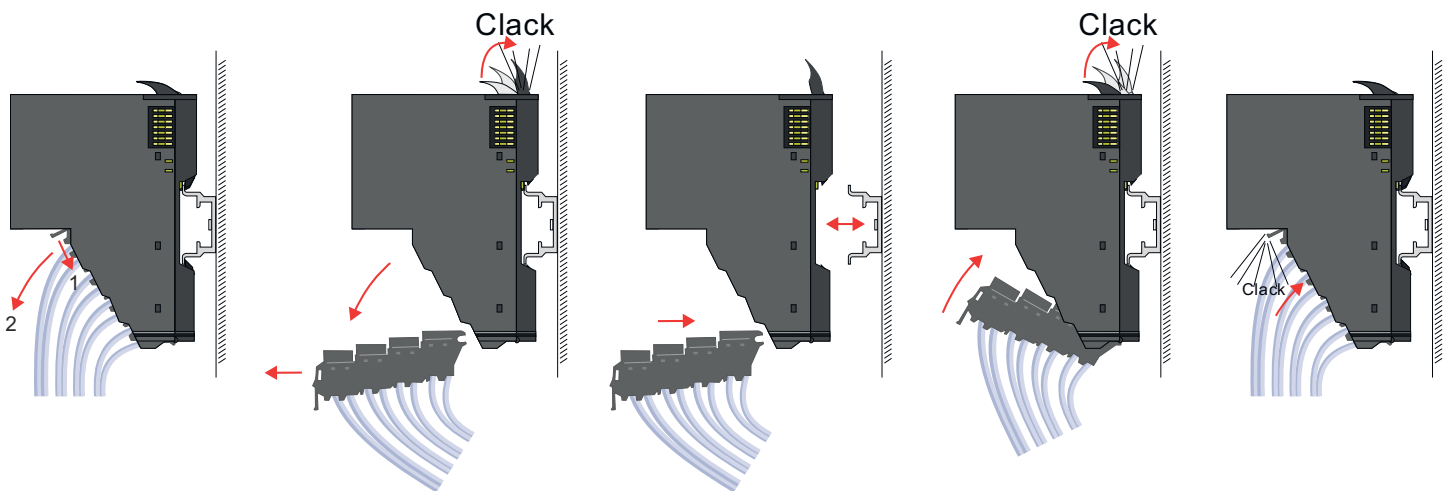

Exchange of a 16x periphery module

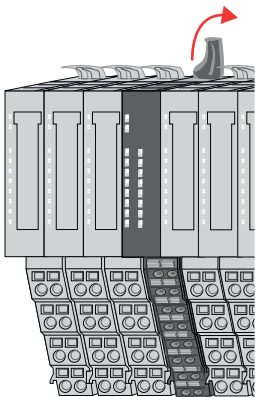

1. ➤ Power-off your system.
2. ➤ Remove if exists the wiring of the module respectively the wired terminal block.
3. ➤



In contrast to 8x periphery modules, you can directly demount and mount 16x periphery modules.

Turn the locking lever of the module to be exchanged upwards.

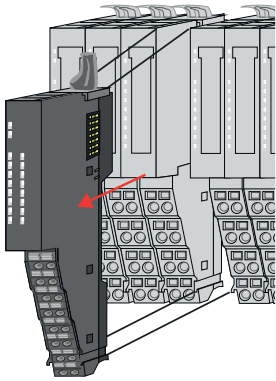

4. ➤ Pull the module.
5. ➤ For mounting turn the locking lever of the module to be mounted upwards.

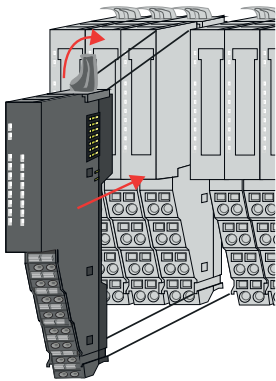

6. ➤ To mount the module put it to the gap between the both modules and push it, guided by the stripes at both sides, to the mounting rail.

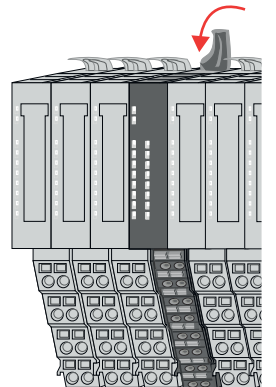

7. ➤ Turn the locking lever downward, again.
8. ➤ Wire your module respectively plug the wired terminal block again.
 - ⇒ Now you can bring your system back into operation.

Exchange of a module group

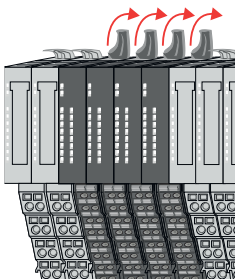

1. ➤ Power-off your system.
2. ➤ Remove if exists the wiring of the module group respectively the wired terminal blocks.
3. ➤

i *In contrast to 8x periphery modules, you can directly demount and mount 16x periphery modules.*

Turn all the locking lever of the module group to be exchanged upwards.

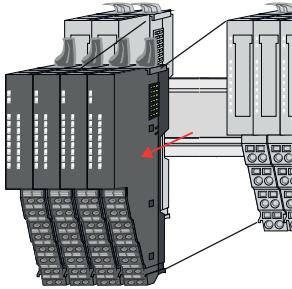

4. ➤ Pull the module group forward.
5. ➤ For mounting turn all the locking lever of the module group to be mounted upwards.

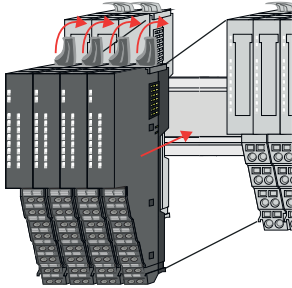

6. ➤ To mount the module group put it to the gap between the both modules and push it, guided by the stripes at both sides, to the mounting rail.

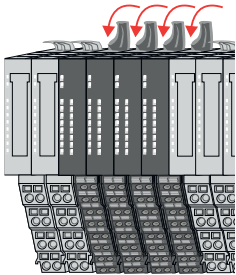

7. ➤ Turn all the locking lever downward, again.
8. ➤ Wire your module group respectively plug the wired terminal blocks again.
⇒ Now you can bring your system back into operation.

2.7 Trouble shooting - LEDs

General

Each module has the LEDs RUN and MF on its front side. Errors or incorrect modules may be located by means of these LEDs.

In the following illustrations flashing LEDs are marked by ☼.

Sum current of the electronic power supply exceeded



Behaviour: After PowerON the RUN LED of each module is off and the MF LED of each module is sporadically on.

Reason: The maximum current for the electronic power supply is exceeded.

Remedy: As soon as the sum current of the electronic power supply is exceeded, always place the power module 007-1AB10. ↪ Chap. 2.5.4 'Wiring power modules' page 26

Error in configuration

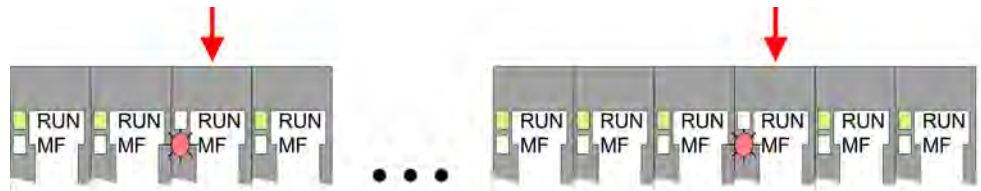

Behaviour: After PowerON the MF LED of one module respectively more modules flashes. The RUN LED remains off.

Reason: At this position a module is placed, which does not correspond to the configured module.

Remedy: Match configuration and hardware structure.

Module failure

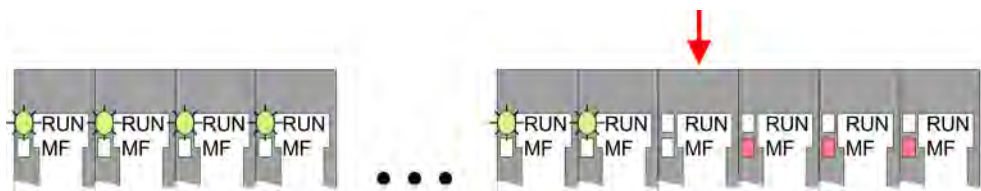

Behaviour: After PowerON all of the RUN LEDs up to the defective module are flashing. With all following modules the MF LED is on and the RUN LED is off.

Reason: The module on the right of the flashing modules is defective.

Remedy: Replace the defective module.

2.8 Industrial security and installation guidelines

2.8.1 Industrial security in information technology

Latest version

This chapter can also be found as a guide '*Industrial IT Security*' at www.yaskawa.eu.com

Hazards

The topic of data security and access protection has become increasingly important in the industrial environment. The increased networking of entire industrial systems to the network levels within the company together with the functions of remote maintenance have all served to increase vulnerability. Hazards can arise from:

- Internal manipulation such as technical errors, operating and program errors and deliberate program or data manipulation.
- External manipulation such as software viruses, worms and Trojans.
- Human carelessness such as password phishing.

Precautions

The most important precautions to prevent manipulation and loss of data security in the industrial environment are:

- Encrypting the data traffic by means of certificates.
- Filtering and inspection of the traffic by means of VPN - "Virtual Private Networks".
- Identification of the user by "Authentication" via safe channels.
- Segmenting in protected automation cells, so that only devices in the same group can exchange data.
- Deactivation of unnecessary hardware and software.

Further Information

You can find more information about the measures on the following websites:

- Federal Office for Information Technology www.bsi.bund.de
- Cybersecurity & Infrastructure Security Agency us-cert.cisa.gov
- VDI / VDE Society for Measurement and Automation Technology www.vdi.de

2.8.1.1 Protection of hardware and applications

Precautions

- Do not integrate any components or systems into public networks.
 - Use VPN "Virtual Private Networks" for use in public networks. This allows you to control and filter the data traffic accordingly.
- Always keep your system up-to-date.
 - Always use the latest firmware version for all devices.
 - Update your user software regularly.
- Protect your systems with a firewall.
 - The firewall protects your infrastructure internally and externally.
 - This allows you to segment your network and isolate entire areas.
- Secure access to your plants via user accounts.
 - If possible, use a central user management system.
 - Create a user account for each user for whom authorization is essential.
 - Always keep user accounts up-to-date and deactivate unused user accounts.
- Secure access to your plants via secure passwords.
 - Change the password of a standard login after the first start.
 - Use strong passwords consisting of upper/lower case, numbers and special characters. The use of a password generator or manager is recommended.
 - Change the passwords according to the rules and guidelines that apply to your application.
- Deactivate inactive communication ports respectively protocols.
 - Only the communication ports that are used for communication should be activated.
 - Only the communication protocols that are used for communication should be activated.
- Consider possible defence strategies when planning and securing the system.
 - The isolation of components alone is not sufficient for comprehensive protection. An overall concept is to be drawn up here, which also provides defensive measures in the event of a cyber attack.
 - Periodically carry out threat assessments. Among others, a comparison is made here between the protective measures taken and those required.
- Limit the use of external storage media.
 - Via external storage media such as USB memory sticks or SD memory cards, malware can get directly into a system while bypassing a firewall.
 - External storage media or their slots must be protected against unauthorized physical access, e.g. by using a lockable control cabinet.
 - Make sure that only authorized persons have access.
 - When disposing of storage media, make sure that they are safely destroyed.
- Use secure access paths such as HTTPS or VPN for remote access to your plant.
- Enable security-related event logging in accordance with the applicable security policy and legal requirements for data protection.

2.8.1.2 Protection of PC-based software

Precautions

Since PC-based software is used for programming, configuration and monitoring, it can also be used to manipulate entire systems or individual components. Particular caution is required here!

- Use user accounts on your PC systems.
 - If possible, use a central user management system.
 - Create a user account for each user for whom authorization is essential.
 - Always keep user accounts up-to-date and deactivate unused user accounts.
- Protect your PC systems with secure passwords.
 - Change the password of a standard login after the first start.
 - Use strong passwords consisting of upper/lower case, numbers and special characters. The use of a password generator or manager is recommended.
 - Change the passwords according to the rules and guidelines that apply to your application.
- Enable security-related event logging in accordance with the applicable security policy and legal requirements for data protection.
- Protect your PC systems by security software.
 - Install virus scanners on your PC systems to identify viruses, trojans and other malware.
 - Install software that can detect phishing attacks and actively prevent them.
- Always keep your software up-to-date.
 - Update your operating system regularly.
 - Update your software regularly.
- Make regular backups and store the media at a safe place.
- Regularly restart your PC systems. Only boot from storage media that are protected against manipulation.
- Use encryption systems on your storage media.
- Perform security assessments regularly to reduce the risk of manipulation.
- Use only data and software from approved sources.
- Uninstall software which is not used.
- Disable unused services.
- Activate a password-protected screen lock on your PC systems.
- Always lock your PC systems as soon as you leave your PC workstation.
- Do not click any links that come from unknown sources. If necessary ask, e.g. on e-mails.
- Use secure access paths such as HTTPS or VPN for remote access to your PC system.

2.8.2 Installation guidelines

General

The installation guidelines contain information about the interference free deployment of a PLC system. There is the description of the ways, interference may occur in your PLC, how you can make sure the electromagnetic compatibility (EMC), and how you manage the isolation.

What does EMC mean?

Electromagnetic compatibility (EMC) means the ability of an electrical device, to function error free in an electromagnetic environment without being interfered respectively without interfering the environment.

The components are developed for the deployment in industrial environments and meets high demands on the EMC. Nevertheless you should project an EMC planning before installing the components and take conceivable interference causes into account.

Possible interference causes

Electromagnetic interferences may interfere your control via different ways:

- Electromagnetic fields (RF coupling)
- Magnetic fields with power frequency
- Bus system
- Power supply
- Protected earth conductor

Depending on the spreading medium (lead bound or lead free) and the distance to the interference cause, interferences to your control occur by means of different coupling mechanisms.

There are:

- galvanic coupling
- capacitive coupling
- inductive coupling
- radiant coupling

Basic rules for EMC

In the most times it is enough to take care of some elementary rules to guarantee the EMC. Please regard the following basic rules when installing your PLC.

- Take care of a correct area-wide grounding of the inactive metal parts when installing your components.
 - Install a central connection between the ground and the protected earth conductor system.
 - Connect all inactive metal extensive and impedance-low.
 - Please try not to use aluminium parts. Aluminium is easily oxidizing and is therefore less suitable for grounding.
- When cabling, take care of the correct line routing.
 - Organize your cabling in line groups (high voltage, current supply, signal and data lines).
 - Always lay your high voltage lines and signal respectively data lines in separate channels or bundles.
 - Route the signal and data lines as near as possible beside ground areas (e.g. suspension bars, metal rails, tin cabinet).
- Proof the correct fixing of the lead isolation.
 - Data lines must be shielded.
 - Analog lines must be shielded. When transmitting signals with small amplitudes the one sided laying of the isolation may be favourable.
 - Cables for frequency inverters, servo and stepper motors must be shielded.
 - Lay the line isolation extensively on an isolation/protected earth conductor rail directly after the cabinet entry and fix the isolation with cable clamps.
 - Make sure that the isolation/protected earth conductor rail is connected impedance-low with the cabinet.
 - Use metallic or metallised plug cases for isolated data lines.
- In special use cases you should appoint special EMC actions.
 - Consider to wire all inductivities with erase links.
 - Please consider luminescent lamps can influence signal lines.
- Create a homogeneous reference potential and ground all electrical operating supplies when possible.
 - Please take care for the targeted employment of the grounding actions. The grounding of the PLC serves for protection and functionality activity.
 - Connect installation parts and cabinets with your PLC in star topology with the isolation/protected earth conductor system. So you avoid ground loops.
 - If there are potential differences between installation parts and cabinets, lay sufficiently dimensioned potential compensation lines.

Isolation of conductors

Electrical, magnetically and electromagnetic interference fields are weakened by means of an isolation, one talks of absorption. Via the isolation rail, that is connected conductive with the rack, interference currents are shunt via cable isolation to the ground. Here you have to make sure, that the connection to the protected earth conductor is impedance-low, because otherwise the interference currents may appear as interference cause.

When isolating cables you have to regard the following:

- If possible, use only cables with isolation tangle.
- The hiding power of the isolation should be higher than 80%.
- Normally you should always lay the isolation of cables on both sides. Only by means of the both-sided connection of the isolation you achieve high quality interference suppression in the higher frequency area. Only as exception you may also lay the isolation one-sided. Then you only achieve the absorption of the lower frequencies. A one-sided isolation connection may be convenient, if:
 - the conduction of a potential compensating line is not possible.
 - analog signals (some mV respectively μA) are transferred.
 - foil isolations (static isolations) are used.
- With data lines always use metallic or metallised plugs for serial couplings. Fix the isolation of the data line at the plug rack. Do not lay the isolation on the PIN 1 of the plug bar!
- At stationary operation it is convenient to strip the insulated cable interruption free and lay it on the isolation/protected earth conductor line.
- To fix the isolation tangles use cable clamps out of metal. The clamps must clasp the isolation extensively and have well contact.
- Lay the isolation on an isolation rail directly after the entry of the cable in the cabinet. Lead the isolation further on to your PLC and don't lay it on there again!

**CAUTION!****Please regard at installation!**

At potential differences between the grounding points, there may be a compensation current via the isolation connected at both sides.

Remedy: Potential compensation line

2.9 General data for the System SLIO**Conformity and approval**

Conformity		
CE	2014/35/EU	Low-voltage directive
	2014/30/EU	EMC directive
Approval		
UL	-	Refer to Technical data
Others		
RoHS	2011/65/EU	Restriction of the use of certain hazardous substances in electrical and electronic equipment

General data for the System SLIO

Protection of persons and device protection

Type of protection	-	IP20
Electrical isolation		
to the field bus	-	electrically isolated
to the process level	-	electrically isolated
Insulation resistance	-	-
Insulation voltage to reference earth		
Inputs / outputs	-	AC / DC 50V, test voltage AC 500V
Protective measures	-	against short circuit

Environmental conditions to EN 61131-2

Climatic		
Storage / transport	EN 60068-2-14	-25...+70°C
Operation		
Horizontal installation hanging	EN 61131-2	0...+60°C
Horizontal installation lying	EN 61131-2	0...+55°C
Vertical installation	EN 61131-2	0...+50°C
Air humidity	EN 60068-2-30	RH1 (without condensation, rel. humidity 10...95%)
Pollution	EN 61131-2	Degree of pollution 2
Installation altitude max.	-	2000m
Mechanical		
Oscillation	EN 60068-2-6	1g, 9Hz ... 150Hz
Shock	EN 60068-2-27	15g, 11ms

Mounting conditions

Mounting place	-	In the control cabinet
Mounting position	-	Horizontal and vertical

EMC	Standard	Comment	
Emitted interference	EN 61000-6-4	Class A (Industrial area)	
Noise immunity zone B	EN 61000-6-2	Industrial area	
		EN 61000-4-2	ESD 8kV at air discharge (degree of severity 3), 4kV at contact discharge (degree of severity 2)
		EN 61000-4-3	HF field immunity (casing) 80MHz ... 1000MHz, 10V/m, 80% AM (1kHz) 1.4GHz ... 2.0GHz, 3V/m, 80% AM (1kHz) 2GHz ... 2.7GHz, 1V/m, 80% AM (1kHz)
		EN 61000-4-6	HF conducted 150kHz ... 80MHz, 10V, 80% AM (1kHz)
		EN 61000-4-4	Burst, degree of severity 3
	EN 61000-4-5	Surge, degree of severity 3 ¹	

1) Due to the high-energetic single pulses with Surge an appropriate external protective circuit with lightning protection elements like conductors for lightning and overvoltage is necessary.

2.9.1 Use in difficult operating conditions



Without additional protective measures, the products must not be used in locations with difficult operating conditions; e.g. due to:

- *dust generation*
- *chemically active substances (corrosive vapors or gases)*
- *strong electric or magnetic fields*

3 Hardware description

3.1 Properties

053-1ML00

- Field bus: MECHATROLINK-III according to IEC 61158, IEC 61784
- MECHATROLINK-III coupler for max. 64 periphery modules
- Supports standard I/O profile (16byte and 64byte mode)
- Multi slave node with max. 9 stations
 - 1 coupler (address extension 00h)
 - Periphery module (from address 01h)
- Max. 492byte input and 492byte output data
 - Coupler: 12byte input and 12byte output data
 - Periphery module: 480byte input and 480byte output data
- Integrated DC 24V power supply for power and electronic section supply of the periphery modules
- Integrated web server
- Configuration is done via software tool respectively web server

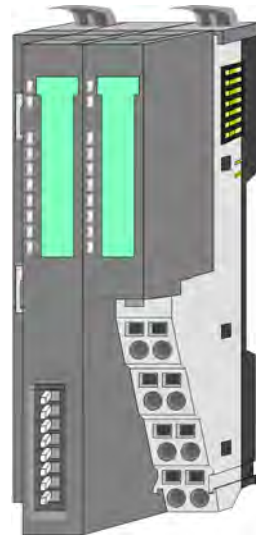

Ordering data

Type	Order number	Description
IM 053ML	053-1ML00	MECHATROLINK-III coupler for System SLIO

3.2 Structure

053-1ML00

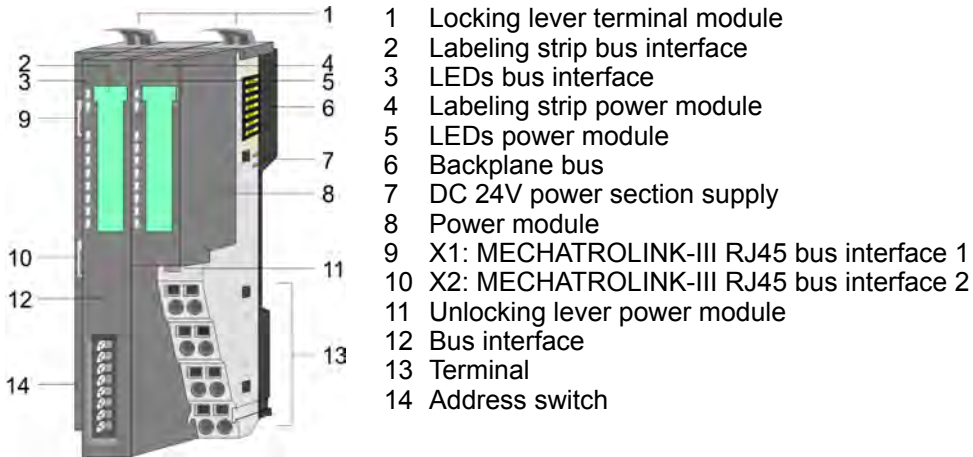

3.2.1 Interfaces

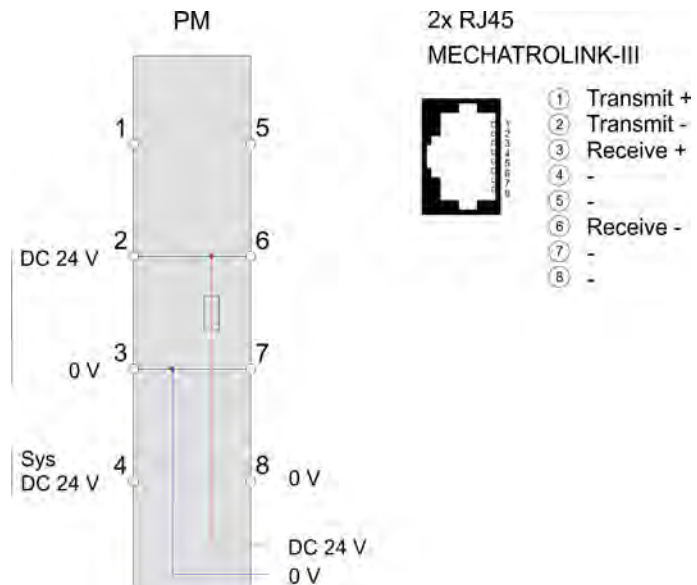

CAUTION!

Bus interface and power module of the bus coupler may not be separated!

Here you may only exchange the electronic module!

PM - Power module

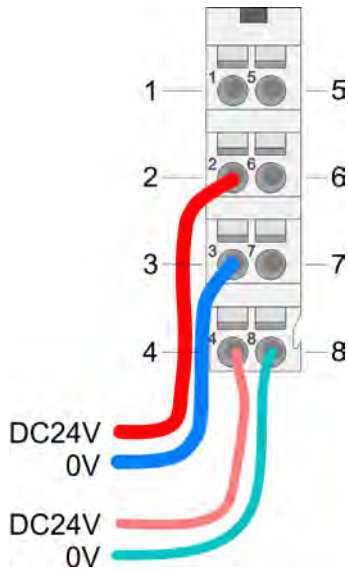

For wires with a core cross-section of 0.08mm² up to 1.5mm².

Pos.	Function	Type	Description
1	---	---	not connected
2	DC 24V	I	DC 24V for power section supply
3	0V	I	GND for power section supply
4	Sys DC 24V	I	DC 24V for electronic section supply
5	---	---	not connected
6	DC 24V	I	DC 24V for power section supply
7	0V	I	GND for power section supply
8	Sys 0V	I	GND for electronic section supply

I: Input

X1/X2: MECHATROLINK-III interface

RJ45 jacks

- MECHATROLINK-III connection via 2 RJ45 jacks (2 ports) by means of a MECHATROLINK cable
- MECHATROLINK-III master (C1 or C2) in the network required for operation
- Cascade and star topology are possible

3.2.2 LEDs

LEDs power module

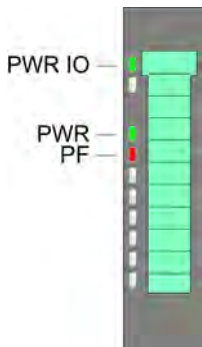





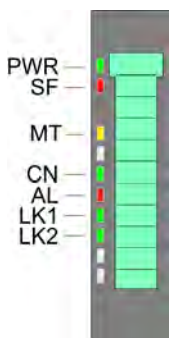





































PWR IO	PWR	PF	Description
■ green	■ green	■ red	
■	X	□	Power section supply OK
■	■	□	Electronic section supply OK
X	X	■	Fuse electronic section supply defective
not relevant: X			

LEDs bus interface



LED	Color	Description
PWR	■ green	Bus interface is power supplied
SF	■ red	System error: Error on System SLIO bus
MT	■ yellow	MECHATROLINK-III mode status (maintenance mode)
CN	■ green	MECHATROLINK-III connection status
AL	■ red	MECHATROLINK-III error status
LK1	■ green	Link port 1: Physical connection to MECHATROLINK-III
LK2	■ green	Link port 2: Physical connection to MECHATROLINK-III

PWR  green	SF  red	MT  yellow	CN  green	AL  red	LK1  green	LK2  green	Description
	X	X	X	X	X	X	The MECHATROLINK-III coupler is power supplied.
		X	X	X	[]	[]	No connection can be established to the MECHATROLINK-III master, but there is a physical connection. LK1 or LK2 is on.
		X					There is no physical connection to Ethernet. LK1 and LK2 is off.
		X	X	X	X	X	<ul style="list-style-type: none"> ■ An unacknowledged diagnostic message is pending. ■ Error on the backplane bus (e.g. module failure, bus faulted). ■ Error during firmware update (shortly visible, then restart).
	 1Hz		X	X	X	X	<ul style="list-style-type: none"> ■ Error in the configuration ■ At least one module does not match the configuration ■ The outputs of all output modules are disabled
	 2Hz		X	X	X	X	<ul style="list-style-type: none"> ■ There is a module with an FPGA version lower than V 228 ■ There is a module which is not supported ■ The outputs of all output modules are disabled
	 1Hz	 1Hz	X	X	X	X	A firmware update is in progress.
			X	X	X	X	MECHATROLINK-III coupler is in <i>maintenance mode</i> and can be configured
			X	X	X	X	MECHATROLINK-III coupler is in <i>standard mode</i>
	X	X	X	 1Hz	X	X	MECHATROLINK-III communication error An error occurred during communication via MECHATROLINK-III
	X	X	X	 2Hz	X	X	MECHATROLINK-III address error The address set on the MECHATROLINK-III coupler is incorrect or invalid
	X	X	X	X		X	Port 1 is physically linked to MECHATROLINK-III
	X	X	X	X	X		Port 2 is physically linked to MECHATROLINK-III

Option: [] | not relevant: X

3.2.3 Address switch

Address switch



An address may only be assigned once in the MECHATROLINK-III network! Changes of the address switch were only recognized after PowerON or a Reset!

The address set on the address switch must always be identical to the device address in your configuration tool!

The address switch serves for the following settings:

- Selection of the operating mode
- Adaptation of the MECHATROLINK-III address

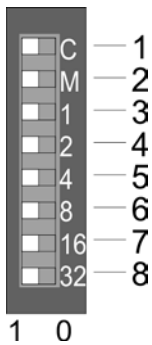

Position	Designation	Description
1	C	Operating mode <ul style="list-style-type: none"> ■ 0: <i>Standard mode</i> (default) <ul style="list-style-type: none"> – Default setting – I/O data transfer and configuration are possible via MECHATROLINK-III – MECHATROLINK-III address selectable via DIP switch (0x03 ... 0x3F) ■ 1: <i>Maintenance mode</i> <ul style="list-style-type: none"> – In this mode, the module can be configured. – Configuration is only possible via the integrated web page or via the configuration tool – Octet of the MECHATROLINK-III address 192.168.1.x selectable via DIP switch (x: 1 ... 63) Please change the operating mode only when powered off!
2	M	Reserved - leave the switch position at 0.
3	$2^0 = 1$	MECHATROLINK-III address: <ul style="list-style-type: none"> ■ Standard mode <ul style="list-style-type: none"> – Address range 0x03 ... 0x3F – Hexadecimal value from position 3 ... 8 – Is the address in the range 0x00 ... 0x02, the address 0x03 is used ■ Maintenance mode <ul style="list-style-type: none"> – Octet of the IP address 192.168.1.x with x: 1 ... 63 – x = decimal value from position 3 ... 8 – If the address 192.168.1.0 is set, the address 192.168.1.1 is used.
4	$2^1 = 2$	
5	$2^2 = 4$	
6	$2^3 = 8$	
7	$2^4 = 16$	
8	$2^5 = 32$	

0 = disabled, 1 = enabled

3.3 Technical data

Order no.	053-1ML00
Type	IM 053ML - MECHATROLINK
Module ID	-
Technical data power supply	
Power supply (rated value)	DC 24 V
Power supply (permitted range)	DC 20.4...28.8 V
Reverse polarity protection	✓
Current consumption (no-load operation)	95 mA
Current consumption (rated value)	0.95 A
Inrush current	3.9 A
I^2t	0.14 A ² s
Max. current drain at backplane bus	3 A
Max. current drain load supply	10 A
Power loss	3 W
Status information, alarms, diagnostics	
Status display	yes
Interrupts	yes, parameterizable
Process alarm	yes, parameterizable
Diagnostic interrupt	yes, parameterizable
Diagnostic functions	yes, parameterizable
Diagnostics information read-out	possible
Supply voltage display	green LED
Service Indicator	yellow LED
Group error display	red SF LED
Channel error display	none
Hardware configuration	
Racks, max.	1
Modules per rack, max.	64
Number of digital modules, max.	64
Number of analog modules, max.	64
Communication	
Fieldbus	MECHATROLINK-III
Type of interface	Ethernet 100 MBit
Connector	2 x RJ45
Topology	-
Electrically isolated	✓

Technical data

Order no.	053-1ML00
Number of participants, max.	-
Node addresses	-
Transmission speed, min.	100 Mbit/s
Transmission speed, max.	100 Mbit/s
Address range inputs, max.	492 Byte
Address range outputs, max.	492 Byte
Number of TxPDOs, max.	-
Number of RxPDOs, max.	-
Functionality MECHATROLINK-III slave	
Supported profile	Standard I/O profiles
Supported transfer cycle	125us, 250us, 500us, 750us, 1ms.... 8ms (every 500us)
Cyclic data size per node	16byte (slave), 64byte (peripheral)
Max. Number of nodes	9 (00h : for slave, 01h-08h for modules)
Supported communication method	Cyclic, Event driven, Message
Supported command "Cyclic"	NOP, ID_RD, CONFIG, ALM_RD, ALM_CLR, SYNC_SET, CONNECT, DISCONNECT, DATA_RWA, DATA_RWS
Supported command "Event driven"	NOP, ID_RD, CONNECT, DISCONNECT
Supported command "Message"	Memory read , Read max message size, Download request, Download data, Download complete
Datasizes	
Input bytes	492
Output bytes	492
Parameter bytes	-
Diagnostic bytes	-
Housing	
Material	PPE / PPE GF10
Mounting	Profile rail 35 mm
Mechanical data	
Dimensions (WxHxD)	48.5 mm x 109 mm x 76.5 mm
Net weight	167.5 g
Weight including accessories	167.5 g
Gross weight	185 g
Environmental conditions	
Operating temperature	0 °C to 60 °C
Storage temperature	-25 °C to 70 °C
Certifications	

Order no.	053-1ML00
UL certification	in preparation
KC certification	in preparation

4 Deployment

4.1 Basics MECHATROLINK-III

Transfer medium

MECHATROLINK-III is compatible to Ethernet in accordance with the IEEE standards. Connection can be either point-to-point or in *cascade* or *star* topology. For use in star topology, always use a *hub module*. The specification of MECHATROLINK-III is listed below.

Parameter	Properties
Transfer cable	CAT5e STP (shielded twisted-pair cable) - crossover Ethernet cable
Connection	RJ45 or industrial miniature I/O connector
Max. network expansion	6300m
Max. distance between 2 stations	100m
Number of connected stations	C1 master station: 1, C2 master station: max. 62 For a cascade topology max. 19 stations can be connected.
Transfer rate	100Mbps
Channel coding	4B/5B MLT-3
Station types	C1 master: Network management station C2 master: Message master station Slave/multi-slave: Passive station
Access control	Master - slave
Number of bytes in the information field	8/16/32/48/64 bytes (can be mixed)
Electrical isolation between device and network	Isolation transformer



- *It is a crossover Ethernet cable to be used.*
- *For a cascaded connection, the number of couplers to be synchronized must be 19 or less.*

4.2 MECHATROLINK-III installation guidelines

Generals to data security

- The topic of data security and access protection have become increasingly important in the industrial environment. The increased networking of entire industrial systems to the network levels within the company together with the functions of remote maintenance have all served to increase vulnerability.
- Threats can arise from internal manipulation like technical errors, operator and program errors respectively from external manipulation like software viruses and worms, trojans and password phishing.

Precautions

The most important precautions to prevent manipulation and loss of data security in the industrial environment are:

- Encrypting the data traffic by means of certificates.
- Filtering and inspection of the traffic by means of VPN - "Virtual Private Networks".
- Identification of the nodes by "Authentication" via save channels.
- Segmenting in protected automation cells, so that only devices in the same group can exchange data.

Guidelines for information security

- With the "VDI/VDE 2182 sheet 1", Information Security in the Industrial Automation - General procedural model, VDI guidelines, the VDI/VDE society for measuring and automation engineering has published a guide for implementing a security architecture in the industrial environment. The guideline can be found at www.vdi.de

Industrial Ethernet

- Due to the open standard of MECHATROLINK-III standard Ethernet components may be used. For industrial environment and due to the high transfer rate of 100MBit/s your MECHATROLINK-III system should consist of Industrial Ethernet components.
- All the devices interconnected to MECHATROLINK-III are located in one and the same network. All the devices in a network can communicate directly with each other.
- A network is physically limited by a router. If devices need to communicate beyond the limits of a network, you have to configure the router so that it allows this communication to take place.

4.2.1 Topology

Cascade

- With the cascade structure all the communication devices are connected via a linear bus topology. Here, the line structure is realized via the RJ45 jacks (port 1/2), which are already integrated in the MECHATROLINK-III devices.
- If a communication member fails, the communication across the failed member is not possible.

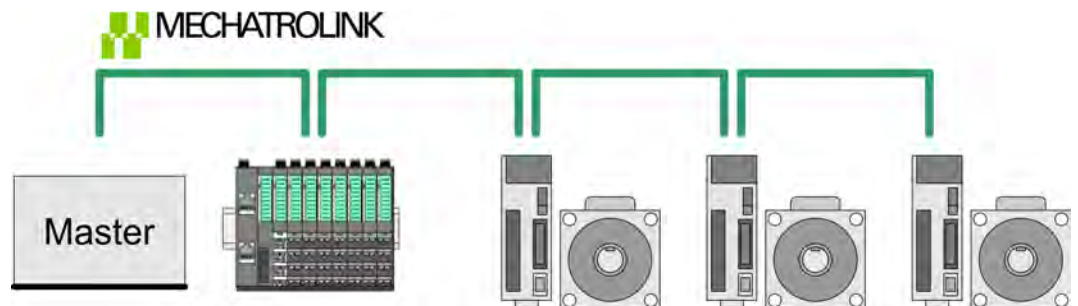

Star

- If you connect communication devices to a *Hub module* like YASKAWA JEPMC-MT2000-E with more than 2 MECHATROLINK-III interfaces, you automatically create a star network topology.
- If an individual MECHATROLINK-III device fails, this does not automatically lead to failure of the entire network, in contrast to other structures. Here, only the subnetwork that contains the faulty MECHATROLINK-III device fails.

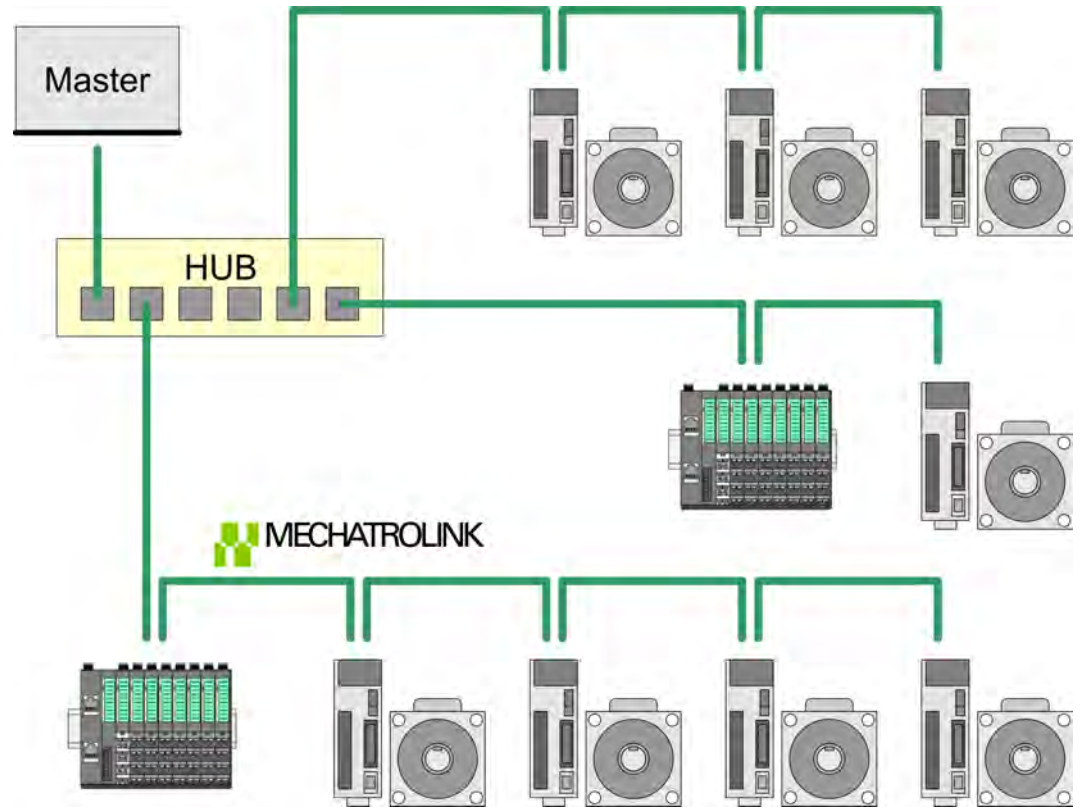

4.3 Accessing the System SLIO

4.3.1 Supported modules

Hardware revision

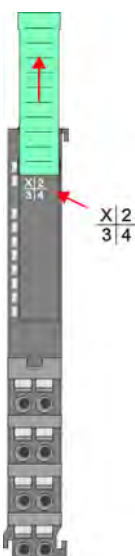

- Please note that modules are only supported which are starting from the specified hardware revision. This corresponds to the FPGA version V228 or higher of the module.
- Modules, which are not listed in the table below, are not supported.
- If there is a module with an older hardware revision or there is a not supported module, the outputs are disabled and the SF LED starts blinking.

Since a module consists of a terminal and electronic module, you will also find information about the hardware revision at the terminal module. This is not relevant here.

- Information about the hardware revision of a module can exclusively be found on the front of the electronic module under the labeling strip. The hardware revision (here 1) is labelled with an X.
- You can also use the web server to determine the hardware revision. ↪ [Chap. 4.6 'Web server' page 64](#)

Order no.	Description	HW rev.
Digital input modules		
021-1BB00	2 inputs	2
021-1BB10	2 fast inputs, input filter, time delay parametrizable	2
021-1BD00	4 inputs	2
021-1BD10	4 fast inputs, input filter, time delay parametrizable	2
021-1BD40	4 inputs, connect 2/3-wire	2
021-1BD50	4 inputs, NPN	2
021-1BF00	8 inputs	2
021-1BF01	8 inputs, 0.5ms	1
021-1BF50	8 inputs, NPN	2
021-1DF00	8 inputs, diagnosis	1

Digital output modules		HW rev.
022-1BB00	2 outputs, output current 0.5A	2
022-1BB90	2 outputs, PWM	2
022-1BD00	4 outputs, output current 0.5A	2
022-1BD20	4 outputs, output current 2A	2
022-1BD50	4 outputs, NPN, output current 0.5A	2
022-1BF00	8 outputs, output current 0.5A	2
022-1BF50	8 outputs, NPN, output current 0.5A	2
022-1HB10	2 relay outputs, DC 30V / AC 230V, output current 3A	4
022-1HD10	4 relay outputs, DC 30V / AC 230V, output current 1.8A	4
022-1DF00	8 outputs, output current 0.5A, diagnosis	1

Analog input modules		HW rev.
031-1BB10	2 inputs 12bit, current 0(4) ... 20mA, 2 wire	2
031-1BB30	2 inputs 12bit, voltage 0 ... 10V	2
031-1BB40	2 inputs 12bit, current 0(4) ... 20mA	2
031-1BB60	2 inputs 12bit, current 0(4) ... 20mA, 2 wire	1
031-1BB70	2 inputs 12bit, voltage -10 ... +10V	2
031-1BB90	2 inputs 16bit Thermocouple, voltage -80mV ... +80mV	4
031-1BD30	4 inputs 12bit, voltage 0 ... 10V	2
031-1BD40	4 inputs 12bit, current 0(4) ... 20mA	2
031-1BD70	4 inputs 12bit, voltage -10 ... +10V	2
031-1CA20	1 input 16(24)bit, DMS and load cells	1
031-1CB30	2 inputs 16bit, voltage 0 ... 10V	2
031-1CB40	2 inputs 16bit, current 0(4) ... 20mA	2
031-1CB70	2 inputs 16bit, voltage -10 ... +10V	2
031-1CD30	4 inputs 16bit, voltage 0 ... 10V	2
031-1CD35	4 inputs 16bit, voltage 0 ... 10V	1
031-1CD40	4 inputs 16bit, current 0(4) ... 20mA	2
031-1CD45	4 inputs 16bit, current 0(4) ... 20mA	1
031-1CD70	4 inputs 16bit, voltage -10 ... +10V	2
031-1LB90	2 inputs 16bit Thermocouple, voltage -80mV ... +80mV (less parameters)	2
031-1PA00	Energy measurement terminal 1/3 phase 230 / 400V, 1A	1
031-1PA10	Energy measurement terminal 1/3 phase 230 / 400V, 5A	2
Analog output modules		HW rev.
032-1BB30	2 outputs 12bit, voltage 0 ... 10V	2
032-1BB40	2 outputs 12bit, current 0(4) ... 20mA	2
032-1BB70	2 outputs 12bit, voltage -10 ... +10V	2
032-1BD30	4 outputs 12bit, voltage 0 ... 10V	2
032-1BD40	4 outputs 12bit, current 0(4) ... 20mA	2
032-1BD70	4 outputs 12bit, voltage -10 ... +10V	2
032-1CB30	2 outputs 16bit, voltage 0 ... 10V	2
032-1CB40	2 outputs 16bit, current 0(4) ... 20mA	1
032-1CB70	2 outputs 16bit, voltage -10 ... +10V	2
032-1CD30	4 outputs 16bit, voltage 0 ... 10V	2
032-1CD40	4 outputs 16bit, current 0(4) ... 20mA	2
032-1CD70	4 outputs 16bit, voltage -10 ... +10V	2
Counter modules		HW rev.
050-1BA00	1 Counter 32bit (AB), DC 24V	2
050-1BA10	1 Counter 32bit (AB), DC 5V (difference signal)	2

Counter modules		HW rev.
050-1BB00	2 Counter 32bit (AB), DC 24V	2
050-1BB30	2 Counter 32bit (AB), DC 24V	2
050-1BB40	Frequency measurement, 2 channels 24Bit, DC 24V	2
050-1BS00	SSI module	3
Power supply modules		HW rev.
007-1AB00	Power supply DC 24V, 10A	1
007-1AB10	Power supply DC 24V, 4A, backplane bus 5V, 2A	1
Distribution modules		HW rev.
001-1BA00	8 * DC 24V	1
001-1BA10	8 * DC 0V	1
001-1BA20	4 * DC 24V, 4 * DC 0V	1
Line extension modules		HW rev.
060-1AA00	IM 060 Line extension (master)	1
061-1BA00	IM 061 Line extension (slave)	1

4.3.2 Overview

After switching on, the coupler automatically detects the modules on the backplane bus and assigns their I/O areas to I/O groups. The assignment happens with the following proceeding:

- The coupler IM 053ML uses the address extension 00h
- The coupler IM 053ML automatically determines the peripheral modules and combines their I/O areas to 60byte groups.
- Each I/O group is assigned to an address extension starting from 01h to max. 08h.
- The offset is always 2bytes.
- If the maximum size of 60bytes is exceeded when assigning an input or output area of a peripheral module, the corresponding I/O area is assigned to the next I/O group. This group gets the next higher address extension.



- *Information concerning the allocation of these areas may be found in the description of the corresponding System SLIO module.*
- *Please consider the System SLIO power and clamp modules do not have any module ID. These may not be recognized by the MECHATROLINK-III coupler and so are not listed respectively considered during slot allocation.*

4.3.3 Example

System

In the following an example of accessing to the System SLIO is shown.

Slot:	0	1	2	3	4	5	6	7
	IM 053ML	SM 021 DI 4x	SM 021 DI 4x	FM 050 Counter	FM 050 Counter	FM 050 Counter	FM 050 Counter	FM 050 Counter
OUT:	Bytes: 12	Bytes: 1	Bytes: 1	Bytes: 12	Bytes: 12	Bytes: 12	Bytes: 12	Bytes: 12
IN:	Bytes: 12			Bytes: 4	Bytes: 4	Bytes: 4	Bytes: 4	Bytes: 4

Coupler 053-1ML00

The coupler 053-1ML00 uses 12bytes each and uses the address extension 00h

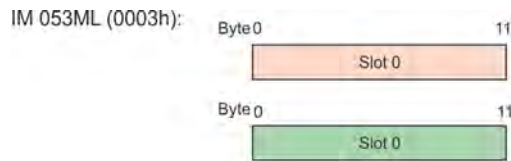

Periphery modules

The coupler 053-1ML00 automatically determines the peripheral modules and combines their I/O areas to 60byte groups.

The 1. I/O group gets the address extension 01h

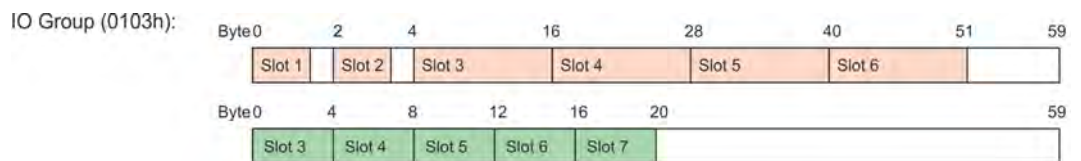

The 2. I/O group is required because the 12bytes no longer fit into group 1 for input.

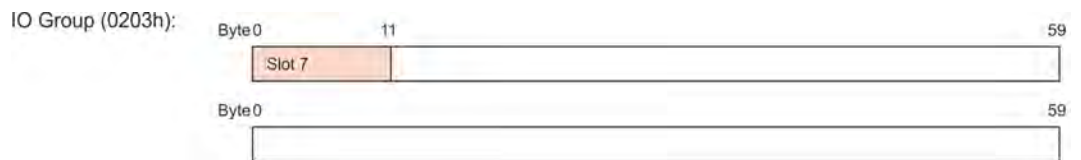

4.4 Communication with the MECHATROLINK-III master

- In the MECHATROLINK-III master the coupler IM 053ML is handled as a multi-slave coupler.
- The master has the address 01h.
- The I/O areas of the periphery modules are accessed via the coupler address (here address 03) and the address extension of the corresponding I/O group.

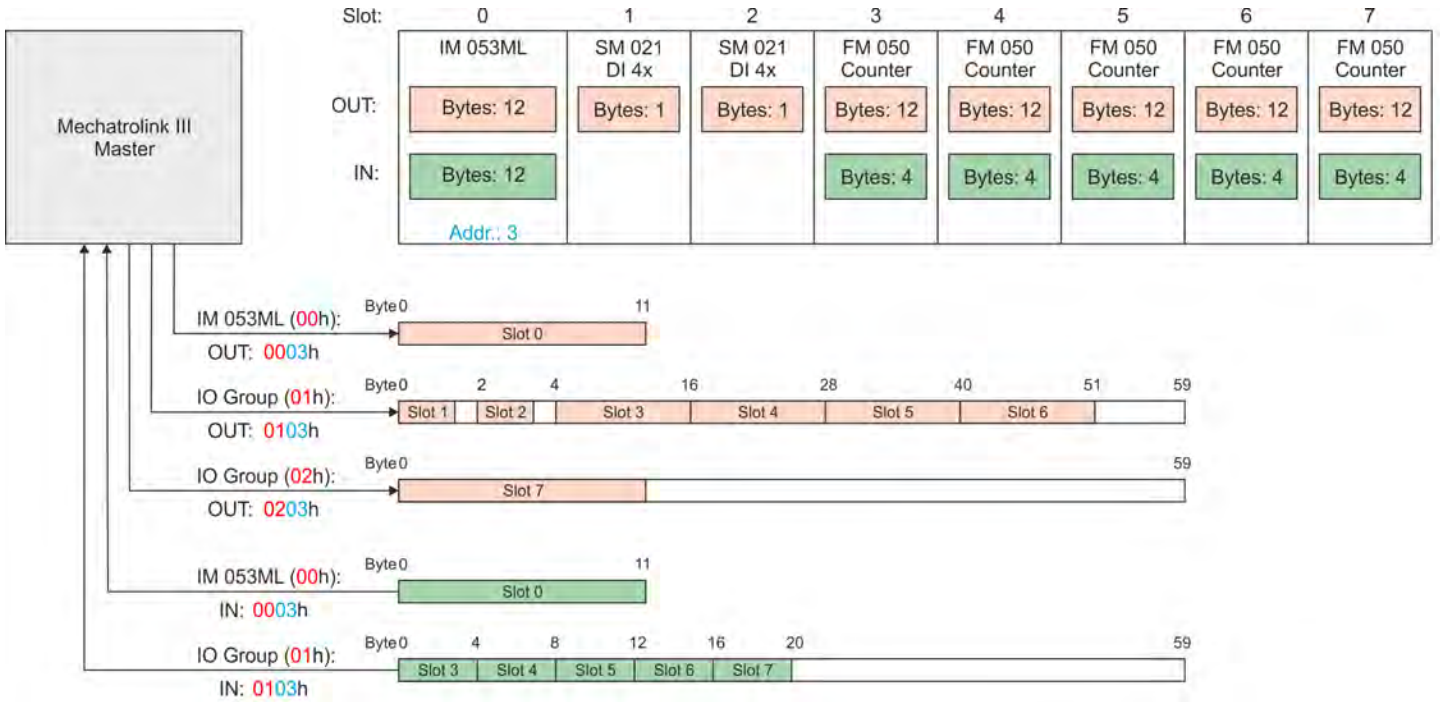

4.5 I/O area of the IM 053ML

Structure

The bus coupler uses 12bytes for input data and 12bytes for output data. In cyclic communication you can access the I/O area via *DATA_RWA* (20h) respectively *DATA_RWS* (21h). The I/O area has the following structure:

Byte	Output data	Input data
0 ... 1	Reserved	Status
2	<i>Coupler command</i>	<i>Command response</i>
3	<i>Command ID</i>	<i>Response ID</i>
4 ... 11	<i>Command data</i>	<i>Response data</i>

Status

Byte	Description
0	<ul style="list-style-type: none"> ■ Bit 0: An error occurred while processing <i>Coupler command</i>. ■ Bit 1: <i>Coupler command</i> is currently being processed.
1	Reserved

Coupler command and *Command response*

For sending a command via *Coupler command*, you receive the command code via *Command response* as confirmation.

Code	Name	Description
0x00	Read interrupt counter	Read the hardware / diagnostic interrupt counter
0x01	Read hardware interrupt slot	Read the hardware interrupt data of a module
0x02	Read diagnostic interrupt slot	Read the diagnostic interrupt data of a module
0x03	Reset interrupt data	Delete the interrupt data of a module
0x04	Read memory	Read the virtual memory
0x05	Write parameter	Write module parameter

Command ID and *Response ID*

ID of the coupler command for identification, if you want to use the command multiple times.

Command data and *Response data*

Use and structure of the data areas depends on the command used.

Read interrupt counter (0x00)

Byte	Command data	Response data
4 ... 7	-	Counter hardware interrupt
8 ... 11	-	Counter diagnostic interrupt

Read hardware interrupt slot (0x01)

Byte	Command data	Response data
4 ... 11	-	Hardware interrupt status <ul style="list-style-type: none"> ■ Bit 0: Slot 1 ■ Bit 1: Slot 2 ■ ... ■ Bit 63: Slot 64

Read diagnostic interrupt slot (0x02)

Byte	Command data	Response data
4 ... 11	-	Diagnostic interrupt status <ul style="list-style-type: none"> ■ Bit 0: Slot 1 ■ Bit 1: Slot 2 ■ ... ■ Bit 63: Slot 64

Reset diagnostic data (0x03)

Byte	Command data	Response data
4 ... 5	Slot number (1 ... 64)	Slot number as response
6 ... 11	-	0 (fix)

Read memory (0x04)

Byte	Command data	Response data
4	Byte size (0 ... 8)	Depends on the virtual memory
5		
6 ... 7	Reserved	
8 ... 11	Offset	

Write parameter (0x05)

Byte	Command data	Response data
4	Parameter ID as value of SX from the manual of the module.	<ul style="list-style-type: none"> ■ 0: no error ■ 1: Module or parameter does not exist ■ 2: Faulty parameter size ■ 3: Parameter can not be overwritten at runtime
5	Slot number (1 ... 64)	
6 ... 7	Size of parameter data in bytes (1 ... 4)	
8 ... 11	Parameter data	

4.6 Web server

Access via IP address

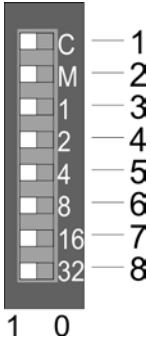

On delivery, the web server is deactivated. The activation happens with the following proceeding:

1. ➤ Switch off the power supply of the *MECHATROLINK-III* coupler.
2. ➤ Set at the address switch the *operating mode 'C'* (position 1) 1: *Maintenance mode*.
3. ➤ At the address switch, set the *MECHATROLINK-III* address as the IP address.
 ↳ *Chap. 3.2.3 'Address switch' page 50*
4. ➤ Switch on the power supply of the *MECHATROLINK-III* coupler.
 - ⇒ The coupler is now in maintenance mode. The integrated web server may be accessed via the following IP address:
 - Subnet mask: 255.255.255.0
 - IP address: 192.168.1.x
with x = decimal value of position 2...8 of the address switch

Structure of the web page

The web page is built dynamically and depends on the number of modules, which are connected to the *MECHATROLINK-III* coupler.



Please consider the System SLIO power and clamp modules do not have any module ID. These may not be recognized by the MECHATROLINK-III coupler and so are not listed respectively considered during slot allocation.



- [1] Module list: *MECHATROLINK-III* coupler and System SLIO modules in plugged order
- [2] Functions for the module, which is selected in the *module list*
- [3] Information respectively input field for the according function



For fast diagnostic missing or incorrectly configured modules are shown after updating the web page in the module list in red. The modules in blue are modules with or without configuration.

**Web page with selected
MECHATROLINK-III coupler**



• Device (... 053-1ML00) ←
 [A] Module 1 (... 021-1BD00)
 [A] Module 2 (... 022-1BD00)

Info Data Parameter Diagnosis Security IP Firmware Configuration

Device (... 053-1ML00) information

Name	Value
Ordering Info	053-1ML00
Serial	00101272
Version	01V10.001
HW Revision	01
Software	01

Info Here order number, serial number and the version of firmware and hardware of the *MECHATROLINK-III* coupler are listed.

Data The size of the process output and the process input image and the offset are shown here.

Parameter This functionality is currently not supported.

Diagnosis In this register diagnostic messages are shown. Please note that some diagnostic messages may be triggered due to an outdated firmware version. The following diagnostic messages are supported:

Code	Description
E000 00YYh	Error at access to the module at slot YY. Please retry after reboot.
E010 00YYh	Error accessing the retentive memory of the module at slot YY. Please try again after a restart respectively delete the parameters in the retentive memory and restart or carry out a firmware update.
A000 00YYh	The module version on slot YY is not supported.
A010 00YYh	
A020 00YYh	The assembled module in slot YY does not match the configured module in the retentive memory.
A030 00YYh	The module in slot YY has been configured and stored in retentive memory but not mounted.
A040 00YYh	Error writing parameter of the module at slot YY. Check your module parameters.

Security This functionality is currently not supported.

IP Here you get the current IP address of the *MECHATROLINK-III* coupler.

Web server

Firmware

With this function you can bring in a firmware update. You can get the appropriate firmware file from Yaskawa. During the firmware update, SF and MT are blinking alternately. When the update is finished, all the red LEDs are switched ON! After this perform a power cycle.

Configuration

In this dialog box, you have the option to save the current module configuration of your *MECHATROLINK-III* coupler externally or to load a saved one. Before saving the module configuration you should delete an existing one.

Web page with selected module

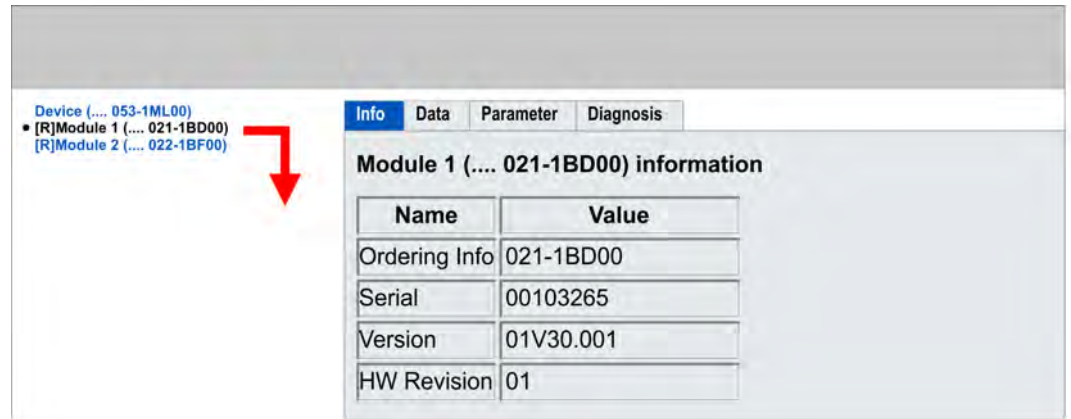

Info

Here product name, order number, serial number, firmware version and hardware state number of the according module are listed.

Data

At *Data* the states of the inputs respectively outputs are listed.

Parameter

If available the parameter data of the corresponding module may be shown and possibly be changed.

Diagnosis

If available the diagnosis data of the selected module can be shown here.

4.7 Virtual memory

Values are transferred in little-endian format, i.e. least significant byte first. These areas are only readable with the ID_RD command code. ↵ 83

Virtual memory has the following structure.

ID area

ID codes	Address	Byte size	Description	Value
-	0000 0000h	4	Reserved	All 0
01h	0000 0004h	4	Vendor ID code	0000 075Ch
02h	0000 0008h	4	Device code	0A04 0C04h
03h	0000 000Ch	4	Device version	0000 0100h
04h	0000 0010h	4	Device definition file version	0000 1000h
05h	0000 0014h	4	Extended address	1 - 9 (Depends on constitution of the modules)
-	0000 0018h	32	Serial no.	Not supported (0 fix)
-	0000 0038h	4	Reserved	0000 0000h
-	0000 003Ch	4	Reserved	0000 0000h
10h	0000 0040h	4	Profile type1	0000 0030h (standard I/O)
11h	0000 0044h	4	Profile version 1	0000 0100h
12h	0000 0048h	4	Profile type 2	0000 00FFh
13h	0000 004Ch	4	Profile version 2	0000 0000h
14h	0000 0050h	4	Profile type 3	0000 00FFh
15h	0000 0054h	4	Profile version 3	0000 0000h
16h	0000 0058h	4	Minimum transmission cycle	12500 (125µs) *
17h	0000 005Ch	4	Maximum transmission cycle	800000 (8ms)
18h	0000 0060h	4	Granularity of transmission cycle	0000 0003h The following values are supported: 125µs, 250µs, 500µs, 750µs, 1...32ms in steps of 0.5ms
19h	0000 0064h	4	Minimum communication cycle	12500 (125µs) *
1Ah	0000 0068h	4	Maximum communication cycle	3200000 (32ms)
1Bh	0000 006Ch	4	Number of transmission bytes	0000 0002h (for bus coupler) 0000 0010h (for peripheral module)
1Ch	0000 0070h	4	Number of transmission bytes (current value)	0000 0002h (for bus coupler) 0000 0010h (for peripheral module)
1Dh	0000 0074h	4	Profile type (current value)	The profile specified by the CONNECT command is output: 0030h at cyclical communication 0001h at acyclic communication
-	0000 0078h	4	Reserved	All 0
-	0000 007Ch	4	Reserved	All 0

Virtual memory

ID codes	Address	Byte size	Description	Value
20h	0000 0080h	4	Supported communication mode	0000 0007h The following modes are supported: Message mode, cyclic and event driven mode
-	0000 0084h	10	MAC address	Not supported (All 0)
-	0000 008Ch	52	Reserved	All 0
30h	0000 00C0h	32	List of supported main commands	0000 0003 6000 E079h The following commands are supported: NOP, ID_RD, CONFIG, ALM_RD, ALM_CLR, SYNC_SET, CONNECT, DISCONNECT, DATA_RWA, DATA_RWS
38h	0000 00E0h	32	List of supported subcommands	All 0
40h	0000 0100h	32	List of supported common parameters	All 0
-	0000 0120h	96	Reserved	All 0
60h	0000 0180	32	List of supported MECHATROLINK message communication sub functions	000E 0000 0002 0042h The following sub functions are supported: memory read, read max. message size, download request, download data, download complete
68h	0000 01A0h	4	Message relay support	0003 0001h The 3-step message relay is supported.
69h	0000 01A4h	4	Timeout period	5 (5s)
6Ah	0000 01A8h	4	Timeout period (for file access commands)	5 (5s)
-	0000 01ACh	84	Reserved	All 0
80h	0000 0200h	32	Name of main device	"IM 053ML"
-	0000 0220h	32	Reserved	All 0
-	0000 0240h	32	Name of sub device 1	Not supported (All 0)
-	0000 0260h	4	Version of sub device 1	Not supported (All 0)
-	0000 0264h	28	Reserved	All 0
-	0000 0280h	32	Name of sub device 2	Not supported (All 0)
-	0000 02A0h	4	Version of sub device 2	Not supported (All 0)
-	0000 02A4h	28	Reserved	All 0
-	0000 02C0h	32	Name of sub device 3	Not supported (All 0)
-	0000 02E0h	4	Version of sub device 3	Not supported (All 0)
-	0000 02E4h	28	Reserved	All 0

*) This value depends on the processing of the corresponding module. 125µs are only possible in asynchronous mode.

Vendor specific area

Address	Byte size	Description	Value
0000 0300h	4	Using number of slot	0 - 64
0000 0304h	28	Reserved	All 0
0000 0320h	32	Slot 0 device name	"0531ML00"

Address	Byte size	Description	Value
0000 0340h	4	Slot 0 input extended address	0
0000 0344h	4	Slot 0 input data start offset	0
0000 0348h	4	Slot 0 input data byte size	12
0000 034Ch	4	Slot 0 output extended address	0
0000 0350h	4	Slot 0 output data start offset	0
0000 0354h	4	Slot 0 output data byte size	12
0000 0358h	4	Slot 0 parameter data size	0
0000 035Ch	4	Reserved	All 0
0000 0360h	32	Slot 1 device name	Value depends on device
0000 0380h	4	Slot 1 input extended address	Value depends on device
0000 0384h	4	Slot 1 input data start offset	Value depends on device
0000 0388h	4	Slot 1 input data byte size	Value depends on device
0000 038Ch	4	Slot 1 output extended address	Value depends on device
0000 0390h	4	Slot 1 output data start offset	Value depends on device
0000 0394h	4	Slot 1 output data byte size	Value depends on device
0000 0398h	4	Slot 1 parameter data size	Value depends on device
0000 039Ch	4	Reserved	All 0
...
0000 1320h	32	Slot 64 device name	Value depends on device
0000 1340h	4	Slot 64 input extended address	Value depends on device
0000 1344h	4	Slot 64 input data start offset	Value depends on device
0000 1348h	4	Slot 64 input data byte size	Value depends on device
0000 134Ch	4	Slot 64 output extended address	Value depends on device
0000 1350h	4	Slot 64 output data start offset	Value depends on device
0000 1354h	4	Slot 64 output data byte size	Value depends on device
0000 1358h	4	Slot 64 parameter data size	Value depends on device

Module information area

Address	Byte size	Description
8000 0000h	256	Slot 0 module information (coupler)
8000 0100h	256	Slot 1 module information
8000 0200h	256	Slot 2 module information
...
8000 3F00h	256	Slot 63 module information
8000 4000h	256	Slot 64 module information

Virtual memory

Address information slot x

Address offset	Description	Size	Value example
+0000h	Device name	32	"YASKAWA 053xxxxx"
+0020h	HW version	8	"Vxxx"
+0028h	FPGA version	8	"V105"
+0030h	SW version	16	"V1.0.0.0"
+0040h	Serial number	32	"12345678"
+0060h	MxFile	16	"Mx000060.105"
+0070h	Product version	16	"V1.2.3.4"
+0080h	Order code	16	"053xxxxx"
+0090h	Module ID	4	12345678h
+0094h	-	108	All 0

Parameter data area

Address	Byte size	Description
8000 5000h	256	Reserved
8000 5100h	256	Slot 1 parameter, depends on module specification.
8000 5200h	256	Slot 2 parameter, depends on module specification.
...
8000 8F00h	256	Slot 63 parameter, depends on module specification.
8000 9000h	256	Slot 64 parameter, depends on module specification.

Diagnostic data area

Address	Byte size	Description
8000 A000h	4byte	Cycle over counter <ul style="list-style-type: none"> ■ Initial value is 0 ■ The counter is incremented if the time for the data exchange is greater than the time for the transmission. ■ If there are timeouts, you must increase the cycle time for data transmission.
8000 A004h	4byte	Current process time for data exchange [μs]
8000 A008h	4byte	Maximum process time for data exchange [μs]
8000 A00Ch	4byte	Reserved
8000 A010h	4byte	Coupler status <ul style="list-style-type: none"> ■ Bit 0: Coupler command error ■ Bit 1: Coupler command busy ■ Bit 2 ... 3: reserved ■ Bit 4: Cycle over error ■ Bit 5 ... 31: reserved

Address	Byte size	Description
8000 A014h	4byte	Last diagnostics message <ul style="list-style-type: none"> Initial value is 0 Please note that some diagnostic messages may be triggered due to an outdated firmware version. Diagnostic messages ↗ 72
8000 A018h	104byte	Reserved
8000 A080h	4byte	Hardware interrupt counter <ul style="list-style-type: none"> Initial value is 0 With each process interrupt, the counter is incremented by 1. With the command <i>Reset diagnostic data</i> (0x03) the counter can be reset. ↗ Chap. 4.5 'I/O area of the IM 053ML' page 62
8000 A084h	4byte	Diagnostic interrupt counter <ul style="list-style-type: none"> Initial value is 0 With each diagnostics interrupt, the counter is incremented by 1. With the command <i>Reset diagnostic data</i> (0x03) the counter can be reset. ↗ Chap. 4.5 'I/O area of the IM 053ML' page 62
8000 A088h	8byte	Hardware interrupt status <ul style="list-style-type: none"> Bit 0: Slot 1 Bit 1: Slot 2 ... Bit 63: Slot 64 With the command <i>Reset diagnostic data</i> (0x03) the status can be reset. ↗ Chap. 4.5 'I/O area of the IM 053ML' page 62
8000 A090h	8byte	Diagnostics interrupt status <ul style="list-style-type: none"> Bit 0: Slot 1 Bit 1: Slot 2 ... Bit 63: Slot 64 With each PowerON a diagnostic interrupt is generated. With the command <i>Reset diagnostic data</i> (0x03) the status can be reset. ↗ Chap. 4.5 'I/O area of the IM 053ML' page 62
8000 A098h	8byte	Reserved
8000 A0A0h	16byte	Hardware interrupt data of slot 1
8000 A0B0h	16byte	Hardware interrupt data of slot 2
...
8000 A490h	16byte	Hardware interrupt data of slot 64
8000 A4A0h	32byte	Diagnostic data of slot 1
8000 A4C0h	32byte	Diagnostic data of slot 2
8000 A4E0h	32byte	Diagnostic data of slot 3
...	...	:
8000 AC80h	32byte	Diagnostic data of slot 64
8000 ACA0h	4byte	1. (latest) diagnostics entry
...
8000 ACDCh	4byte	16. diagnostics entry

Alarms and warnings

Diagnostic messages

Code	Description
E000 00YYh	Error at access to the module at slot YY. Please retry after reboot.
E010 00YYh	Error accessing the retentive memory of the module at slot YY. Please try again after a restart respectively delete the parameters in the retentive memory and restart or carry out a firmware update.
A000 00YYh	The module version on slot YY is not supported.
A010 00YYh	
A020 00YYh	The assembled module in slot YY does not match the configured module in the retentive memory.
A030 00YYh	The module in slot YY has been configured and stored in retentive memory but not mounted.
A040 00YYh	Error writing parameter of the module at slot YY. Check your module parameters.

4.8 Alarms and warnings

Alarm list

Category	Alarm code	COMM_ ALM	Meaning	Remedy
Communication setting error	0E41h	0	<p>The received data size does not match the data size at the local station. After the start of the communication, the status of data reception is abnormal.</p> <ul style="list-style-type: none"> ■ Alarm acknowledgement: possible ■ Output behavior: All is 0 	Check the number of transmission bytes. Check the communication setting of the controller.
Communication establishment error	0E40h	B	<p>When receiving a CONNECT command, an unsupported transfer cycle was set.</p> <ul style="list-style-type: none"> ■ Alarm acknowledgement: impossible ■ Output behavior: All is 0 	Check the communication cycle setting of the controller.
Communication error	0E60h	9	<p>Data reception errors occurred twice in a row after the execution of the CONNECT command was completed. (Influence of noise etc.)</p> <ul style="list-style-type: none"> ■ Alarm acknowledgement: possible ■ Output behavior: All is 0 	Check the communication settings of the controller. Take countermeasures against faults. To clear the alarm state, send the command ALM_CLR. If the alarm persists, replace the coupler.
	0E62h	8	<p>FCS errors occurred twice in a row after completing the CONNECT command. (Influence of noise etc.)</p> <ul style="list-style-type: none"> ■ Alarm acknowledgement: possible ■ Output behavior: All is 0 	Check the communication settings of the controller. Take countermeasures against faults. To clear the alarm state, send the command ALM_CLR.

Category	Alarm code	COMM_ ALM	Meaning	Remedy
	0E63h	A	The synchronous frame not received state was detected twice consecutively after completing the execution of the CONNECT command. (Influence of noise etc.) <ul style="list-style-type: none"> ■ Alarm acknowledgement: possible ■ Output behavior: All is 0 	
System error	0B6Ah	0	The initialization process of the communication LSI failed. <ul style="list-style-type: none"> ■ Alarm acknowledgement: impossible ■ Output behavior: All is 0 	Replace the coupler.

List of Warnings - Communication error (COMM_ALM)

Category	Warning Code	COMM_ ALM	Meaning	Remedy
Communication warnings	0960h	2	Communication error <ul style="list-style-type: none"> ■ Alarm acknowledgement: necessary ■ Output behavior: Values still remain 	Check the communication settings. Take countermeasures against faults.
	0962h	1	FCS error <ul style="list-style-type: none"> ■ Alarm acknowledgement: necessary ■ Output behavior: Values still remain 	
	0963h	3	The time for the cyclic data exchange has exceeded the time for the data transfer. <ul style="list-style-type: none"> ■ Alarm acknowledgement: necessary ■ Output behavior: Values still remain 	Increase the cycle time for data transfer.

List of Warnings - Command error (CMD_ALM)

Category	Warning code	CMD_ALM	Meaning	Remedy
Warning for data setting	094Ah	9	Parameter numbers or data addresses are faulty. <ul style="list-style-type: none"> ■ Alarm acknowledgement: automatic ■ Output behavior: Values still remain 	Check the contents of the command data sent by the controller. (Check the setting for each command and parameter.)
	094Bh	9	The data in the command are invalid. <ul style="list-style-type: none"> ■ Alarm acknowledgement: automatic ■ Output behavior: Values still remain 	
Command warning	095Bh	8	An unsupported command was received. <ul style="list-style-type: none"> ■ Alarm acknowledgement: automatic ■ Output behavior: Values still remain 	Check the command transmission sequence of the controller. (See the conditions for each command.)

Alarms and warnings

Category	Warning code	CMD_ALM	Meaning	Remedy
	095Fh	8	An invalid command was received. <ul style="list-style-type: none">■ Alarm acknowledgement: automatic■ Output behavior: Values still remain	
	097Ah	C	A command that is not allowed in this communication phase has been received. <ul style="list-style-type: none">■ Alarm acknowledgement: automatic■ Output behavior: Values still remain	

4.9 MECHATROLINK-III specification

4.9.1 Phases of the communication

4.9.1.1 State machine

Each MECHATROLINK-III slave implements a state machine for communication. Here the following phases and transitions are defined.

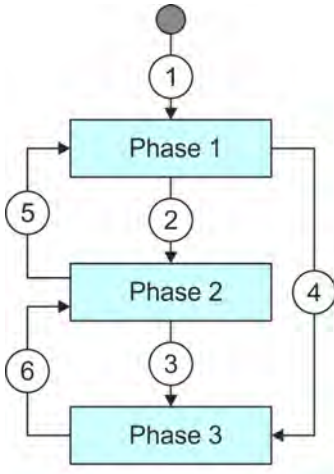

Phase 1 Device is waiting for communication set-up

Phase 2 Asynchronous communication - the device is in maintenance mode and can be configured.

Phase 3 Synchronous communication - the device is in synchronous data exchange.

1 Automatic transition to *phase 1* with PowerON.

2 Transition to *phase 2* with CONNECT ↵ 87

3 Transition to *phase 3* with SYNC_SET ↵ 87

4 Transition to *phase 3* with CONNECT and set SYNCMODE ↵ 87

5 Transition to *phase 1* with DISCONNECT ↵ 89

6 Interrupts triggers transition to *phase 2*.

4.9.1.2 Time chart I/O data

General

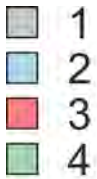

In the bus coupler the following processes are executed based on transmission cycle.

- 1 Network process
- 2 Output to modules
- 3 Input from modules
- 4 Internal process

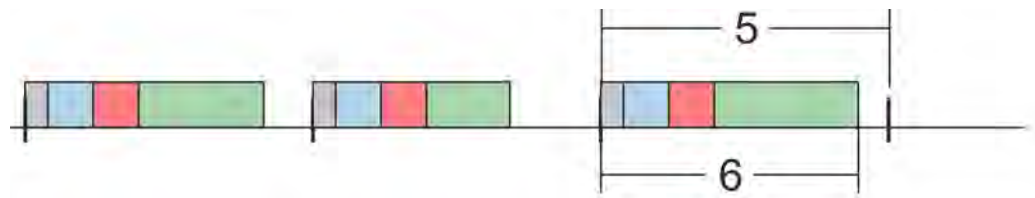

- 5 Transmission cycle
- 6 Process time

Process time exceeds transmission time

In case of the process time exceeds the transmission time (called cycle over), the next cycle is skipped and the process is executed again by the next transmission interrupt.

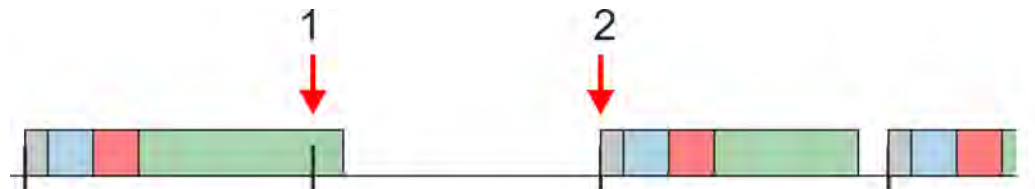

- 1 Transmission cycle exceeds process time - the next cycle is skipped.
- 2 Process is executed by next transmission interrupt

Behavior of the input data If cycle over occurred, the input data are delayed one transmission cycle.

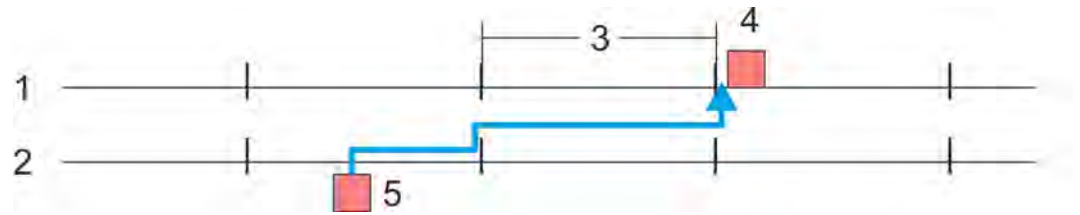

- 1 MECHATROLINK-III master
- 2 MECHATROLINK-III coupler
- 3 Transmission cycle
- 4 Application detects input
- 5 Input from modules

Behavior of the output data If cycle over occurred, the output data are delayed one transmission cycle.

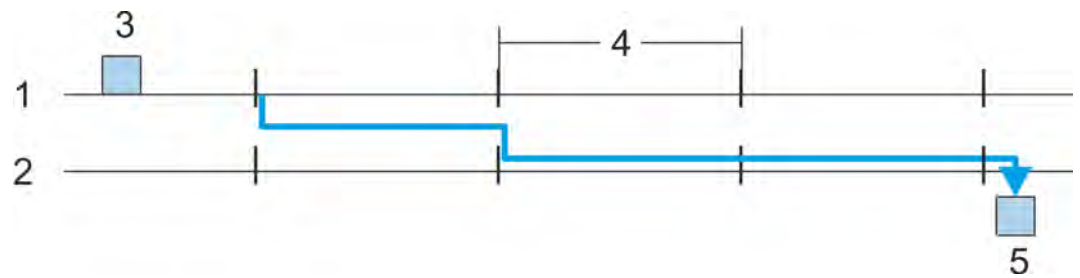

- 1 MECHATROLINK-III master
- 2 MECHATROLINK-III coupler
- 3 Output value in application is set
- 4 Transmission cycle
- 5 Output at module

Asynchronous communication In asynchronous communication (phase 2), the communication is not influenced by a cycle over. The transmission cycle can be smaller than the maximum process time.

Synchronous communication In synchronous communication (phase 3), with an cycle over a warning is triggered (A.980) and the phase is changed to phase 2. To avoid this you have to preset the transmission cycle time, which is bigger than the maximum process time.

4.9.2 Standard IO profile

4.9.2.1 Standard I/O profile command format

4.9.2.1.1 Overview

The MECHATROLINK-III communication specifications specify the standard I/O profile for data exchange with the System SLIO. The following table shows the command types, which are applied in the standard I/O profile and indicates whether the command is supported by the corresponding System SLIO module.

Byte	Command	Response	Reference
0	CMD	RCMD	↪ Chap. 4.9.2.1.2 'Command Code (CMD/RCMD)' page 77
1	WDT	RWDT	↪ Chap. 4.9.2.1.3 'Watchdog Data (WDT/RWDT)' page 78
2	CMD_CTRL	CMD_STAT	↪ Chap. 4.9.2.1.4 'Command Control (CMD_CTRL)' page 78
3			↪ Chap. 4.9.2.1.5 'CMD_STAT' page 79
4 ... 63	CMD_DATA	RSP_DATA	↪ Chap. 4.9.4 'Command detail' page 83

4.9.2.1.2 Command Code (CMD/RCMD)

The following table lists the commands, which are applied in the standard I/O profile and indicates, whether or not each command is supported by the System SLIO.

Profile	Command Code	Command	Operation	Supported by System SLIO
Common commands	00h	NOP	No operation ↪ 83	Yes
	01h	PRM_RD	Read parameter	No
	02h	PRM_WR	Write parameter	No
	03h	ID_RD	Read ID ↪ 83	Yes
	04h	CONFIG	Device setup request ↪ 84	Yes
	05h	ALM_RD	Read alarm/warning ↪ 85	Yes
	06h	ALM_CLR	Clear alarm/warning state ↪ 86	Yes
	0Dh	SYNC_SET	Request for establishing synchronization ↪ 87	Yes
	0Eh	CONNECT	Request for establishing connection ↪ 87	Yes
	0Fh	DISCONNECT	Request for releasing connection ↪ 89	Yes
	1Bh	PPRM_RD	Read memory	No
	1Ch	PPRM_WR	Write memory	No
	1Dh	MEM_RD	Read stored parameter ↪ 89	Yes
1Eh	MEM_WR	Write stored parameter ↪ 91	Yes	
Standard I/O commands	20h	DATA_RWA	Data read/write command (asynchronous) ↪ 92	Yes
	21h	DATA_RWS	Data read/write command (synchronous) ↪ 93	Yes

4.9.2.1.3 Watchdog Data (WDT/RWDT)

During synchronous communications, the C1 master station exchanges synchronous data with its slave stations every communication cycle. These synchronous data are called watchdog data. Watchdog data are used for the detection of synchronous communication establishment and imperfect synchronization.

Data format

The *WDT* and *RWDT* field of the C1 master station and each slave station are used. MN data come from C1 master and RSN data from slave station. The data format of each field is as shown below.

WDT - Command data

Bit 7 ... Bit 4	Bit 3 ... Bit 0
SN: The <i>RSN</i> value of <i>RWDT</i> to be copied	MN: Incremented by one for each communication

RWDT - Response data

Bit 7 ... Bit 4	Bit 3 ... Bit 0
RSN: Incremented by one for each communication	MN value of <i>WDT</i> to be copied

Error detection

If the watchdog data of the remote station is other than the previous value incremented by 1 during the synchronous communication, an error will be detected except in the following cases:

- The C1 master station transmits a *DISCONNECT* command, as request to release connection, in the next communication cycle.
- A communication error or transmission error has already been detected.

4.9.2.1.4 Command Control (CMD_CTRL)

The following describes the 2 bytes *CMD_CTRL* as part of the MECHATROLINK-III command format. The *CMD_CTRL* area is specified as shown below by the communication specification. Note that the designation in this field is valid even when a *CMD_ALM* has occurred.

CMD_CTRL

Bit 15 ... 8	Bit 7 ... 6	Bit 5 ... 4	Bit 3	Bit 2 ... 0
Reserved	CMD_ID	Reserved	ALM_CLR	Reserved

ALM_CLR: Clear communication alarm/warning

Value	Reference
0	Clear alarm/warning disabled.
1	Clear alarm/warning triggered.

- Clears the alarm/warning state with edge 0-1.
- The same processing as when *ALM_CLR_MODE* = 0 for the *ALM_CLR* command (the current alarm/warning state is cleared) is performed.
- The *ALM_CLR* bit is used effectively to clear the *COMM_ALM* warning state.

CMD_ID: Command ID

- This is not used with standard I/O profile commands.

4.9.2.1.5 CMD_STAT

The following describes the 2 bytes *CMD_STAT* as part of the MECHATROLINK-III command format. The *CMD_STAT* area is specified as shown below by the communication specification. Note that the designation in this field is valid even when a *CMD_ALM* has occurred.

Bit 15 ... 12	Bit 11 ... 8	Bit 7 ... 6	Bit 5 ... 4	Bit 3	Bit 2	Bit 1	Bit 0
COMM_ALM	CMD_ALM	RCMD_ID	Reserved	ALM_CLR_CMP	CMDRDY	D_WAR	D_ALM

D_ALM

Value	Reference
1	The device is in the alarm state.
0	Other (includes the states corresponding to <i>COMM_ALM</i> or <i>CMD_ALM</i>)

- When a device-specific alarm other than the alarm state specified by *COMM_ALM* and *CMD_ALM* has occurred, the *D_ALM* status bit is set to 1.
- *D_ALM* is independent of *COMM_ALM* and *CMD_ALM*.
- When the slave station shifts from the device alarm state to the normal state as a result of the execution of the *ALM_CLR* command and *CMD_CTRL.ALM_CLR*, this bit is set to 0.

D_WAR

Value	Reference
1	The device is in the warning state.
0	Other (includes the states corresponding to <i>COMM_ALM</i> or <i>CMD_ALM</i>)

- The bit that indicates the device warning state of the slave station. When a device-specific warning other than the warning state specified by *COMM_ALM* or *CMD_ALM* has occurred, the *D_WAR* status bit is set to 1.
- *D_WAR* is independent of *COMM_ALM* and *CMD_ALM*.
- When the slave station shifts from the device warning state to the normal state as a result of the execution of the *ALM_CLR* command and *CMD_CTRL.ALM_CLR*, this bit is set to 0.

CMDRDY

Value	Reference
1	Command reception enabled.
0	Other

- *CMDRDY* = 0 means that command processing is in progress. While *CMDRDY* = 0, the System SLIO continues to process the current command, so the System SLIO will discard new commands received while *CMDRDY* = 0.
- Only the *DISCONNECT* command is executed immediately regardless of the *CMDRDY* value.
- Completion of command execution is confirmed in accordance with the completion confirmation method of each command.
- The hold time for *CMDRDY* = 0 is specified by individual commands.
- If command execution is possible despite an alarm or warning state, *CMDRDY* is set to 1.

ALM_CLR_CMP

Value	Reference
1	Completion of execution of <i>ALM_CLR</i> .
0	Other

- *ALM_CLR_CMP* = 1 means that *CMD_CTRL.ALM_CLR* = 1 has been received and alarm clear processing has been completed.
- *ALM_CLR_CMP* can be cancelled by setting "0" for *CMD_CTRL.ALM_CLR*.

RCMD_ID

- This is not used in the standard I/O profile.

CMD_ALM

Code	Contents	Remark	
	0	Normal	-
Warning	1	-	These do not occur with this module.
	2	-	
	3	-	
	4	-	
	5	-	
	6	-	
	7	-	
Alarm	8	Unsupported command received	System SLIO notifies the alarm state and the command is not executed.
	9	Invalid data	
	A	-	
	B	-	
	C	Phase error	
	D	-	
	E	-	
	F	-	

Notifies the command error state.

- The code that indicates a command error. *CMD_ALM* is independent of *COMM_ALM*, *D_ALM* and *D_WAR*.
- If a normal command is received after the occurrence of a command error, *CMD_ALM* is automatically cleared.
- The phase doesn't change even if the status of *CMD_ALM* is not "0". ↪ *Chap. 4.9.1 'Phases of the communication' page 75*

COMM_ALM

Code	Contents	Remark	
	0	Normal	-
Warning	1	FCS error	Occurs when an error is detected once.
	2	Command data not received	
	3	Synchronous frame not received	
	4	-	
	5	-	
	6	-	
	7	-	
Alarm	8	FCS error	Occurs if an error is detected twice consecutively using the error detection method for warning 1, described above.
	9	Command data not received	
	A	Synchronous frame not received	
	B	Synchronization time interval error	
	C	Phase error	
	D	WDT error	
	E	-	
	F	-	

Notifies the command error state.

- The code that indicates the error state of MECHATROLINK-III communication.
- *COMM_ALM* is cleared with edge 0-1 of *CMD_CTRL.ALM_CLR* or by the *ALM_CLR* command.

4.9.2.1.6 Command to extended address

When the following commands are commanded to any extended addresses, they are all processed as commands to the coupler module. If you want to command to peripheral modules, you have to use the *Coupler command* area. ↪ *Chap. 4.5 'I/O area of the IM 053ML' page 62*

- The commands that are processed on extended address
 - NOP
 - CONNECT
 - DISCONNECT
- The commands that are processed as the command of coupler module
 - ID_RD
 - CONFIG
 - ALM_RD
 - ALM_CLR
 - SYNC_SET
 - MEM_RD
 - MEM_WR

4.9.3 ID information acquisition profile

Data format

Byte	Command	Response	Reference
0	CMD	RCMD	↪ <i>Chap. 4.9.3.1 'Command Code (CMD/RCMD)' page 82</i>
1	WDT	RWDT	This function is currently not supported.
2	CMD_CTRL	CMD_START	↪ <i>Chap. 4.9.2.1.4 'Command Control (CMD_CTRL)' page 78</i>
3			↪ <i>Chap. 4.9.2.1.5 'CMD_STAT' page 79</i>
4 ... 15	CMD_DATA	RSP_DATA	↪ <i>Chap. 4.9.3.1 'Command Code (CMD/RCMD)' page 82</i>

4.9.3.1 Command Code (CMD/RCMD)

The following table shows the command types, which are applied in the ID information acquisition profile and indicates whether the command is supported by the corresponding System SLIO module.

Command code	Command	Operation	Supported by System SLIO
00h	NOP	No operation ↪ 83	Yes
03h	ID_RD	Read ID ↪ 83	Yes
0Eh	CONNECT	Request for establishing connection ↪ 87	Yes
0Fh	DISCONNECT	Request for releasing connection ↪ 89	Yes
1Dh	MEM_RD	Read stored parameter ↪ 89	No

4.9.4 Command detail

4.9.4.1 No operation command *NOP* (00h)

The *NOP* command is used for network control. The current state is returned as a response.

Confirmation of completion

- Confirm that $RCMD = NOP$ (00h) and $CMD_STAT.CMDRDY = 1$.
- When $CMD_STAT.D_ALM$ or $CMD_STAT.D_WAR = 1$, use *ALM_RD* to read out the current alarm code and take appropriate action.
- When $CMD_STAT.CMD_ALM$ or $CMD_STAT.COMM_ALM \neq 1$, take appropriate action according to the codes. ↪ *Chap. 4.9.2.1.5 'CMD_STAT' page 79*

Command classification

- Device group: Common command group
- Communication type: Asynchronous communication command

Data format

Byte	Command	Response	Reference
0	NOP (00h)	NOP (00h)	
1	WDT	RWDT	↪ <i>Chap. 4.9.2.1.3 'Watchdog Data (WDT/RWDT)' page 78</i>
2	CMD_CTRL	CMD_STAT	↪ <i>Chap. 4.9.2.1.4 'Command Control (CMD_CTRL)' page 78</i>
3			↪ <i>Chap. 4.9.2.1.5 'CMD_STAT' page 79</i>
4 ... 63	Reserved (0)	Reserved (0)	

4.9.4.2 Read ID command *ID_RD* (03h)

The *ID_RD* command is used to read the ID of a device. This command reads the product information as ID data. The ID data is selected in detail by specifying *ID_CODE*.

Confirmation of completion

- Confirm that $RCMD = ID_RD$ (03h) and $CMD_STAT.CMDRDY = 1$ and also the setting for *ID_CODE*, *OFFSET* and *SIZE* of the response.
- When $CMD_STAT.D_ALM$ or $CMD_STAT.D_WAR = 1$, use *ALM_RD* to read out the current alarm code and take appropriate action.
- When $CMD_STAT.CMD_ALM$ or $CMD_STAT.COMM_ALM \neq 0$, take appropriate action according to the codes. ↪ *Chap. 4.9.2.1.5 'CMD_STAT' page 79*

Command classification

- Device group: Common command group
- Communication type: Asynchronous communication command

Data format

Byte	Command	Response	Reference
0	ID_RD (03h)	ID_RD (03h)	
1	WDT	RWDT	↪ <i>Chap. 4.9.2.1.3 'Watchdog Data (WDT/RWDT)' page 78</i>
2	CMD_CTRL	CMD_STAT	↪ <i>Chap. 4.9.2.1.4 'Command Control (CMD_CTRL)' page 78</i>
3			↪ <i>Chap. 4.9.2.1.5 'CMD_STAT' page 79</i>
4	ID_CODE	ID_CODE	ID_Code ↪ <i>Chap. 4.7 'Virtual memory' page 67</i>

Byte	Command	Response	Reference
5	OFFSET	OFFSET	<ul style="list-style-type: none"> Can be used in <i>phases 2 and 3</i>. ↪ <i>Chap. 4.9.1 'Phases of the communication' page 75</i> When the <i>ID_CODE</i> data is invalid, 9h is set for <i>CMD_ALM</i>. When the <i>OFFSET</i> data is invalid, 9h is set for <i>CMD_ALM</i>. When the <i>SIZE</i> data does not match, 9h is set for <i>CMD_ALM</i>. When <i>CMD_ALM</i> = 9h occurs, the ID becomes an indefinite value.
6	SIZE	SIZE	
7			
8 ... 63	Reserved (0)	ID	

4.9.4.3 Setup device command CONFIG (04h)

This command is used to set up devices. The contents of the processing to be executed are specified by the product specifications. A product that does not have the corresponding functions must immediately return a response for process completion.

Confirmation of completion

- Confirm that *RCMD* = *CONFIG* (04h) and *CMD_STAT.CMDRDY* = 1 and also the setting for the *CONFIG_MOD* of the response.
- When *CMD_STAT.D_ALM* or *CMD_STAT.D_WAR* = 1, use *ALM_RD* to read out the current alarm or warning codes and take appropriate action.
- When *CMD_STAT.CMD_ALM* or *CMD_STAT.CMD_COMM* ≠ 0, take appropriate action according to the codes. ↪ *Chap. 4.9.2.1.5 'CMD_STAT' page 79*

Command classification

- Device group: Common command group
- Communication type: Asynchronous communication command

Data format

Byte	Command	Response	Reference
0	CONFIG (04h)	CONFIG (04h)	
1	WDT	RWDT	↪ <i>Chap. 4.9.2.1.3 'Watchdog Data (WDT/RWDT)' page 78</i>
2	CMD_CTRL	CMD_STAT	↪ <i>Chap. 4.9.2.1.4 'Command Control (CMD_CTRL)' page 78</i>
3			↪ <i>Chap. 4.9.2.1.5 'CMD_STAT' page 79</i>
4	CONFIG_MOD	CONFIG_MOD	<ul style="list-style-type: none"> Can be used in <i>phases 2 and 3</i>. ↪ <i>Chap. 4.9.1 'Phases of the communication' page 75</i> When the <i>CONFIG_MOD</i> data is invalid, 9h is set for <i>CMD_ALM</i>.
5 ... 63	Reserved (0)	ID	

CONFIG_MOD: Configuration mode

Value	Reference
0	Parameter re-calculation and setup
1	Common parameter batch writing into nonvolatile memory (not supported)
2	Parameter initialization to factory defaults

Status during execution of CONFIG command

Status	Before Execution	During Execution	After Execution
ALM	current status	current status	current status
CMDRDY	1	0	1
Other	current status	not defined	current status

- The table shows each status before, during, and after the execution of *CONFIG* command.

4.9.4.4 Read alarm or warning command ALM_RD (05h)

The *ALM_RD* command is used to read the alarm or warning state. The current alarm or warning state is read to *ALM_DATA* as an alarm or warning code.

Confirmation of completion

- Confirm that *RCMD* = *ALM_RD* (05h) and *CMD_STAT.CMDRDY* = 1 and also the setting for the *ALM_RD_MOD* and *ALM_INDEX* of the response.

Command classification

- Device group: Common command group
- Communication type: Asynchronous communication command

Data format

Byte	Command	Response	Reference
0	ALM_RD (05h)	ALM_RD (05h)	
1	WDT	RWDT	↪ Chap. 4.9.2.1.3 'Watchdog Data (WDT/RWDT)' page 78
2	CMD_CTRL	CMD_STAT	↪ Chap. 4.9.2.1.4 'Command Control (CMD_CTRL)' page 78
3			↪ Chap. 4.9.2.1.5 'CMD_STAT' page 79
4	ALM_RD_MOD	ALM_RD_MOD	<ul style="list-style-type: none"> ■ Can be used in phases 2 and 3. ↪ Chap. 4.9.1 'Phases of the communication' page 75 ■ If the <i>ALM_RD_MOD</i> data is invalid, 9 is set for <i>CMD_ALM</i>. ■ If the <i>ALM_INDEX</i> data is invalid, 9 is set for <i>CMD_ALM</i>.
5			
6	ALM_INDEX	ALM_INDEX	
7			
9 ... 63	Reserved (0)	ALM_DATA	

ALM_RD_MOD: Read mode

Value	Reference
0	<ul style="list-style-type: none"> ■ Reads the current alarm/warning state ■ Max. 12 alarms/warnings (2 bytes / 1 alarm or warning, byte 8 to 31) ■ When the number of alarms/warnings is less than 12, 0 is set to the <i>ALM_DATA</i> part where there is no alarm/warning.
1	<ul style="list-style-type: none"> ■ Reads the alarm/warning history ■ Max. 12 records (2 bytes / record, byte 8 to 31) ■ When the number of alarm/warning records is less than 12, 0 is set to the <i>ALM_DATA</i> part where there is no alarm/warning.

Value	Reference
2	Individually reads the current alarm/warning details (not supported).
3	Individually reads the alarm/warning history details (not supported).

- *ALM_INDEX*: Alarm index (not supported)
Set to 0.
- *ALM_DATA*: Alarm/warning code

4.9.4.5 Clear alarm or warning command *ALM_CLR* (06h)

The *ALM_CLR* command is used to clear the alarm or warning state. It changes the state of a slave station, but does not eliminate the cause of the alarm or warning. *ALM_CLR* should be used to clear the state after the cause of the alarm or warning has been eliminated. When a communication error (reception error) or synchronous communication error (watchdog data error) occurs during synchronous communications, use *SYNC_SET* to restore synchronous communications after executing *ALM_CLR*.

Confirmation of completion

- Confirm that *RCMD* = *ALM_CLR* (06h) and *CMD_STAT.CMDRDY* = 1 and also the setting for the *ALM_CLR_MOD* of the response.
- When *CMD_STAT.D_ALM* or *CMD_STAT.D_WAR* = 1, use *ALM_RD* to read out the current alarm code and take appropriate action.
- When *CMD_STAT.CMD_ALM* or *CMD_STAT.COMM_ALM* ≠ 0, take appropriate action according to the codes. ↪ [Chap. 4.9.2.1.5 'CMD_STAT' page 79](#)

Command classification

- Device group: Common command group
- Communication type: Asynchronous communication command

Data format

Byte	Command	Response	Reference
0	<i>ALM_CLR</i> (06h)	<i>ALM_CLR</i> (06h)	
1	WDT	RWDT	↪ Chap. 4.9.2.1.3 'Watchdog Data (WDT/RWDT)' page 78
2	<i>CMD_CTRL</i>	<i>CMD_STAT</i>	↪ Chap. 4.9.2.1.4 'Command Control (CMD_CTRL)' page 78
3			↪ Chap. 4.9.2.1.5 'CMD_STAT' page 79
4	<i>ALM_CLR_MOD</i>	<i>ALM_CLR_MOD</i>	<ul style="list-style-type: none"> ■ Can be used in <i>phases</i> 2 and 3. ↪ Chap. 4.9.1 'Phases of the communication' page 75 ■ If the <i>ALM_CLR_MOD</i> data is invalid, 9 is set for <i>CMD_ALM</i>.
5			
6 ... 63	Reserved (0)	Reserved (0)	

ALM_CLR_MOD: Clear alarm mode

Value	Reference
0	Clears the current alarm/warning state.
1	Clears the alarm/warning history.

4.9.4.6 Establish synchronous communication command SYNC_SET (0Dh)

The *SYNC_SET* command is used to start synchronous communications. Synchronous communications start at the completion of execution of this command. When synchronous communication is reset to asynchronous communication because of occurrence of an error, such as a communication error, use this command to restore the synchronous communications. Synchronization is established on the base of the edge change of the watchdog data (WDT) in this command. The C1 master station holds this command until the completion of processing of this command. After the completion of execution of this command, the watchdog data error detection will start.

Confirmation of completion

- Confirm that *RCMD* = *SYNC_SET* (0Dh) and *CMD_STAT.CMDRDY* = 1.
- When *CMD_STAT.D_ALM* or *CMD_STAT.D_WAR* = 1, use *ALM_RD* to read out the current alarm code and take appropriate action.
- When *CMD_STAT.CMD_ALM* or *CMD_STAT.COMM_ALM* ≠ 0, take appropriate action according to the codes. ↪ *Chap. 4.9.2.1.5 'CMD_STAT' page 79*

Command classification

- Device group: Common command group
- Communication type: Asynchronous communication command

Data format

Byte	Command	Response	Reference
0	SYNC_SET (0Dh)	SYNC_SET (0Dh)	
1	WDT	RWDT	↪ <i>Chap. 4.9.2.1.3 'Watchdog Data (WDT/RWDT)' page 78</i>
2	CMD_CTRL	CMD_STAT	↪ <i>Chap. 4.9.2.1.4 'Command Control (CMD_CTRL)' page 78</i>
3			↪ <i>Chap. 4.9.2.1.5 'CMD_STAT' page 79</i>
4 ... 63	Reserved (0)	Reserved (0)	<ul style="list-style-type: none"> ■ In <i>phase 3</i>, this command is ignored. ↪ <i>Chap. 4.9.1 'Phases of the communication' page 75</i> ■ When <i>COMM_ALM</i> = 8h (FCS error) or 9h (no response) occurs, send this command to restart synchronous communications.

4.9.4.7 Establish connection command CONNECT (0Eh)

The *CONNECT* command is used to establish a MECHATROLINK connection. When the command has been completed, the control of slave stations is started by means of MECHATROLINK communication.

Confirmation of completion

- Confirm that *RCMD* = *CONNECT* (0Eh) and *CMD_STAT.CMDRDY* = 1 and also the setting for *VER*, *COM_MODE*, *COM_TIM* and *PROFILE_TYPE* of the response.
- When *CMD_STAT.D_ALM* or *CMD_STAT.D_WAR* = 1, use *ALM_RD* to read out the current alarm code and take appropriate action.
- When *CMD_STAT.CMD_ALM* or *CMD_STAT.COMM_ALM* ≠ 0, take appropriate action according to the codes. ↪ *Chap. 4.9.2.1.5 'CMD_STAT' page 79*

Command classification

- Device group: Common command group
- Communication type: Asynchronous communication command

Data format

Byte	Command	Response	Reference
0	CONNECT (0Eh)	CONNECT (0Eh)	
1	WDT	RWDT	↪ Chap. 4.9.2.1.3 'Watchdog Data (WDT/RWDT)' page 78
2	CMD_CTRL	CMD_STAT	↪ Chap. 4.9.2.1.4 'Command Control (CMD_CTRL)' page 78
3			↪ Chap. 4.9.2.1.5 'CMD_STAT' page 79
4	VER	VER	<ul style="list-style-type: none"> ■ Can be used in <i>phase 1</i>. ↪ Chap. 4.9.1 'Phases of the communication' page 75 ■ In <i>phases 2</i> and <i>3</i>, this command is ignored. ■ If the <i>VER</i> data is invalid, 1 or 9 is set for <i>CMD_ALM</i>. ■ If the <i>COM_TIM</i> data is invalid, 1 or 9 is set for <i>CMD_ALM</i>. ■ If the <i>PROFILE_TYPE</i> data is invalid, 1 or 9 is set for <i>CMD_ALM</i>.
5	COM_MOD	COM_MOD	
6	COM_TIM	COM_TIM	
7	PROFILE_TYPE	PROFILE_TYPE	
8 ... 63	Reserved (0)	Reserved (0)	

- *VER*: MECHATROLINK application layer version
VER = 30h

COM_MOD: Communication mode

Bit 7	Bit 6	Bit 5	Bit 4	Bit 3	Bit 2	Bit 1	Bit 0
SUBCMD	Reserved (0)			DTMODE		SYNC-MODE	Reserved (0)

SYNCMODE: Synchronous communication setting

Value	Reference
1	Starts synchronous communications (Watchdog data error detection enabled. Possible to use synchronous communication commands.)
0	Starts asynchronous communications (Watchdog data error detection disabled. Impossible to use synchronous communication commands.)

DTMODE: Communication method

Value	Reference
00	Single transmission
01	Sequential transmission (not supported)
10	Reserved
11	Reserved

SUBCMD: Subcommand setting

Value	Reference
0	Subcommand disabled

COM_TIM: Communication cycle setting

Value	Reference
0	Sets multiples of the transmission cycle as the communication cycle. Example: The transmission cycle is 0.5 ms and the communication cycle is 2 ms, then $COM_TIM = 4$ ($2/0.5 = 4$)

- **PROFILE_TYPE**: Profile type setting
Sets the profile type to be used.
 - 00h: ID Information Acquisition Profile
 - 30h: Standard I/O profile

4.9.4.8 Release connection command DISCONNECT (0Fh)

When terminating a communication connection, the C1 master station transmits the *DISCONNECT* command for two or more communication cycles. At this time, the slave station interrupts current processing and then performs the initialization required to reestablish the connection. It then waits for the connect establishment request from the C1 master station. The *DISCONNECT* command can be sent regardless of the state of the *CMD_STAT.CMDRDY* bit. If the *DISCONNECT* command is sent when the *CMD_STAT.CMDRDY* state bit is 0, processing is interrupted and this command is processed.

Confirmation of completion

- Control with the command sending time of the C1 master station as two or more communication cycles.

Command classification

- Device group: Common command group
- Communication type: Asynchronous communication command

Data format

Byte	Command	Response	Reference
0	DISCONNECT (0Fh)	DISCONNECT (0Fh)	<ul style="list-style-type: none"> ■ Can be used in all <i>phases</i>. ↪ <i>Chap. 4.9.1 'Phases of the communication' page 75</i> ■ Upon receipt of the <i>DISCONNECT</i> command, operation shifts to <i>phase 1</i>. ■ When the control power is turned OFF at the same time the <i>DISCONNECT</i> command is sent, the response data is indefinite.
1 ... 63	Reserved (0)	Reserved (0)	

4.9.4.9 Read memory content command MEM_RD (1Dh)

The *MEM_RD* command is used to read the data on the virtual memory by specifying the starting address and the data size of the virtual memory. If the reading is not successfully completed due to an incorrect designation, such as invalid starting address or data size, a warning will be created. When a warning is detected, the warning bit and warning code are set in the response. The *ADDRESS* and *SIZE* in the response are the values specified in the command, whether or not the reading has been completed. ↪ *Chap. 4.7 'Virtual memory' page 67*

Confirmation of completion

- Confirm that *RCMD* = *MEM_RD* (1Dh), *CMD_STAT.CMDRDY* = 1 and also the setting for *ADDRESS* and *SIZE* of the response.
- When *CMD_STAT.ALM* or *CMD_STAT.WAR* = 1, use *ALM_RD* to read out the current alarm or warning code and take appropriate action.
- When *CMD_STAT.CMD_ALM* or *CMD_STAT.COMM_ALM* ≠ 0, take appropriate action according to the codes. ↪ *Chap. 4.9.2.1.5 'CMD_STAT' page 79*

Command classification

- Device group: Common command group
- Communication type: Asynchronous communication command

Data format

Byte	Command	Response	Reference
0	MEM_RD (1Dh)	MEM_RD (1Dh)	
1	WDT	RWDT	↪ <i>Chap. 4.9.2.1.3 'Watchdog Data (WDT/RWDT)' page 78</i>
2	CMD_CTRL	CMD_STAT	↪ <i>Chap. 4.9.2.1.4 'Command Control (CMD_CTRL)' page 78</i>
3			↪ <i>Chap. 4.9.2.1.5 'CMD_STAT' page 79</i>
4	Reserved (0)	Reserved (0)	<ul style="list-style-type: none"> ■ Can be used in <i>phases 2</i> and <i>3</i>. ↪ <i>Chap. 4.9.1 'Phases of the communication' page 75</i> ■ If any of the command errors below occur, 9 is set for <i>CMD_ALM</i> <ul style="list-style-type: none"> – The <i>MODE</i> data is invalid – The <i>DATA_TYPE</i> data is invalid – <i>SIZE</i> > 4 – The <i>ADDRESS</i> data is invalid. ■ For errors other than the above, an alarm can be specified in the product specifications Example: By allocating the reserved area to read alarms, etc.
5	MODE/ DATA_TYPE	MODE/ DATA_TYPE	
6	SIZE	SIZE	
7			
8 ... 63	Reserved (0)	Reserved (0)	

MODE/DATA_TYPE: Mode/Data type

Bit 7	Bit 6	Bit 5	Bit 4	Bit 3	Bit 2	Bit 1	Bit 0
MODE				DATA_TYPE			

MODE: Read mode

Value	Reference
0	Reserved by system
1	Volatile memory Reads from a volatile memory such as SRAM.
2	Nonvolatile memory (not supported) Reads from a nonvolatile memory such as E ² PROM
3 ... F	Reserved by system

DATA_TYPE: Data type

Value	Reference
0	Reserved by system
1	Byte type (not supported)
2	Short type
3	Long type
4	Long long type (not supported)
5 ... F	Reserved by system

- **SIZE:** Number of data to read
- **ADDRESS:** Starting address to read
- **DATA:** Data

4.9.4.10 Write memory content command MEM_WR (1Eh)

The *MEM_WR* command is used to write data to the virtual memory by specifying the starting address, data size, and the virtual memory date. If the writing processing is not successfully completed due to an incorrect designation such as invalid starting address and data size, a warning is created. When a warning is detected, the warning bit and warning code are set in the response. The *DATA* in the response is the value specified in the command, whether or not the writing has been completed. ↪ *Chap. 4.7 'Virtual memory' page 67*

Confirmation of completion

- Confirm that *RCMD = MEM_WR (1Eh)*, *CMD_STAT.CMDRDY = 1* and also the setting for *ADDRESS*, *SIZE* and *DATA* of the response.
- When *CMD_STAT.ALM* or *CMD_STAT.D_WAR = 1*, use *ALM_RD* to read out the current alarm or warning code and take appropriate action.
- When *CMD_STAT.CMD_ALM* or *CMD_STAT.COMM_ALM ≠ 0*, take appropriate action according to the codes. ↪ *Chap. 4.9.2.1.5 'CMD_STAT' page 79*

Command classification

- Device group: Common command group
- Communication type: Asynchronous communication command

Data format

Byte	Command	Response	Reference
0	MEM_WR (1Eh)	MEM_WR (1Eh)	
1	WDT	RWDT	↪ <i>Chap. 4.9.2.1.3 'Watchdog Data (WDT/RWDT)' page 78</i>
2	CMD_CTRL	CMD_STAT	↪ <i>Chap. 4.9.2.1.4 'Command Control (CMD_CTRL)' page 78</i>
3			↪ <i>Chap. 4.9.2.1.5 'CMD_STAT' page 79</i>
4	Reserved (0)	Reserved (0)	<ul style="list-style-type: none"> ■ Can be used in <i>phases 2</i> and <i>3</i>. ↪ <i>Chap. 4.9.1 'Phases of the communication' page 75</i> ■ If any of the command errors below occur, 9 is set for <i>CMD_ALM</i> <ul style="list-style-type: none"> – The <i>MODE</i> data is invalid – The <i>DATA_TYPE</i> data is invalid – <i>SIZE > 4</i> – The <i>ADDRESS</i> data is invalid. ■ For errors other than the above, an alarm can be specified in the product specifications
5	MODE/ DATA_TYPE	MODE/ DATA_TYPE	
6	SIZE	SIZE	
7			

Byte	Command	Response	Reference
8 ... 11	ADDRESS	ADDRESS	Example: By allocating the reserved area to read alarms, etc.
12 ... 63	DATA	DATA	

MODE/DATA_TYPE: Mode/Data type

Bit 7	Bit 6	Bit 5	Bit 4	Bit 3	Bit 2	Bit 1	Bit 0
MODE				DATA_TYPE			

MODE: Write mode

Value	Reference
0	Reserved by system
1	Volatile memory Writes to a volatile memory such as SRAM.
2	Nonvolatile memory (not supported) Writes to a nonvolatile memory such as E ² PROM
3 ... F	Reserved by system

DATA_TYPE: Data type

Value	Reference
0	Reserved by system
1	Byte type (not supported)
2	Short type
3	Long type
4	Long long type (not supported)
5 ... F	Reserved by system

- *SIZE*: Number of data to write
- *ADDRESS*: Starting address to write
- *DATA*: Data

4.9.4.11 Data READ/WRITE_A (Asynchronous) command DATA_RWA (20h)

This command updates (asynchronously) I/O data.

Confirmation of completion

- Confirm that *RCMD* = *DATA_RWA* (20h) and *CMD_STAT.COMDRDY* = 1.
- When *CMD_STAT.D_ALM* or *CMD_STAT.D_WAR* = 1, use *ALM_RD* to read out the current alarm code and take appropriate action.
- When *CMD_STAT.CMD_ALM* or *CMD_STAT.COMM_ALM* ≠ 0, take appropriate action according to the codes. ↪ *Chap. 4.9.2.1.5 'CMD_STAT' page 79*

Command classification

- Device group: I/O command group
- Communication type: Asynchronous communication command

Data format

Byte	Command	Response	Reference
0	DATA_RWA (20h)	DATA_RWA (20h)	
1	WDT	RWDT	↪ Chap. 4.9.2.1.3 'Watchdog Data (WDT/RWDT)' page 78
2	CMD_CTRL	CMD_STAT	↪ Chap. 4.9.2.1.4 'Command Control (CMD_CTRL)' page 78
3			↪ Chap. 4.9.2.1.5 'CMD_STAT' page 79
4 ... 63	OUTPUT data	INPUT data	<ul style="list-style-type: none"> ■ INPUT data are always updated. ■ Can be used in phases 2 and 3. ↪ Chap. 4.9.1 'Phases of the communication' page 75

4.9.4.12 Data READ/WRITE_S (Synchronous) command DATA_RWS (21h)

This command updates (synchronously) I/O data.

Confirmation of completion

- Confirm that $RCMD = DATA_RWS$ (21h) and $CMD_STAT.CMDRDY = 1$
- When $CMD_STAT.D_ALM$ or $CMD_STAT.D_WAR = 1$, use ALM_RD to read out the current alarm code and take appropriate action
- When $CMD_STAT.CMD_ALM$ or $CMD_STAT.COMM_ALM \neq 0$, take appropriate action according to the codes ↪ Chap. 4.9.2.1.5 'CMD_STAT' page 79

Command classification

- Device group: I/O command group
- Communication type: Synchronous communication command

Data format

Byte	Command	Response	Reference
0	DATA_RWS (21h)	DATA_RWS (21h)	
1	WDT	RWDT	↪ Chap. 4.9.2.1.3 'Watchdog Data (WDT/RWDT)' page 78
2	CMD_CTRL	CMD_STAT	↪ Chap. 4.9.2.1.4 'Command Control (CMD_CTRL)' page 78
3			↪ Chap. 4.9.2.1.5 'CMD_STAT' page 79
4 ... 63	OUTPUT data	INPUT data	<ul style="list-style-type: none"> ■ In phase 2, Ch is set for COM_ALM. ■ Can be used in phase 3. ↪ Chap. 4.9.1 'Phases of the communication' page 75

4.9.5 MECHATROLINK message communication sub functions

Sub functions

Function code	Sub function	Operation	Option
42h	01h	Memory read	-
	11h	Read max. message size	-
	31h	Download request	Only for configuration tool
	32h	Download data	Only for configuration tool
	33h	Download complete	Only for configuration tool

Sub function detail - memory read (01h)

Byte	Command	Normal response	Error response
0	Slave address	MEM_RD (1Dh)	Slave address
1	Function code (42h)	Function code (42h)	Function code (42h) + 80h (C2h)
2	Extended address	Extended address	Extended address
3	Command status	Response status	Response status
4	Sub function code (01h)	Sub function code (01h)	Sub function code (01h)
5	MODE/ DATA_TYPE (11h)	MODE/ DATA_TYPE (11h)	Error code <ul style="list-style-type: none"> ■ 02h: Address error ■ 04h: Data type error
6	Number of data bytes	Number of data bytes	Reserved (00h)
7			
8 ... n	Start address	1. data	Error detected address
...		...	
n		n. data	

MODE/DATA_TYPE: Mode/Data type

Bit 7	Bit 6	Bit 5	Bit 4	Bit 3	Bit 2	Bit 1	Bit 0
MODE				DATA_TYPE			

MODE: Read mode

Value	Reference
0	Reserved by system
1	Volatile memory Reads from a volatile memory such as SRAM
2	Nonvolatile memory (not supported) Reads from a nonvolatile memory such as E ² PROM
3 ... F	Reserved by system

DATA_TYPE: Data type

Value	Reference
0	Reserved by system
1	Byte type
2	Short type
3	Long type
4	Long long type
5 ... F	Reserved by system

Sub function detail - read max. message size (11h)

Byte	Command	Normal response	Error response
0	Slave address	MEM_RD (1Dh)	Slave address
1	Function code (42h)	Function code (42h)	Function code (42h) + 80h (C2h)
2	Extended address	Extended address	Extended address
3	Command status	Response status	Response status
4	Sub function code (11h)	Sub function code (11h)	Sub function code (01h)
5	Reserved (00h)	Reserved (00h)	Reserved (00h)
6	Reserved (00h)	Reserved (00h)	Reserved (00h)
7			
8 ... n		Max. message size <ul style="list-style-type: none"> ■ C1 message: 960byte ■ C2 message: 260byte 	When the reserved data ≠ 0, you will get an error response.

4.9.6 Command sequence

The following figure shows the basic flow of commands to communicate with the System SLIO.

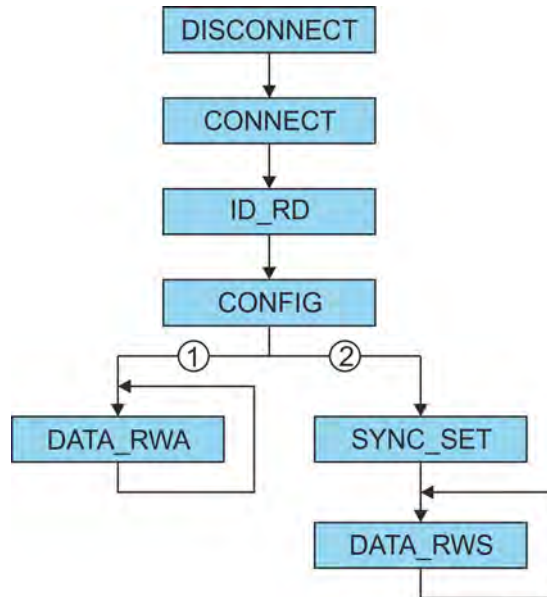

- 1 Asynchronous communication
- 2 Synchronous communication

All of the above commands must be commanded to all stations including extended addresses. The next command must be commanded after confirming the completion of all stations including the extended addresses. ↪ [Chap. 4.9.4 'Command detail' page 83](#)

4.10 Sample application

4.10.1 Overview

Activation of the web server

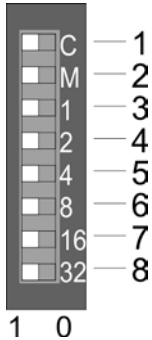

Below, the operation of a system of a IM 053-1ML00 together with a YASKAWA MP3000 series is shown.

1. ➤ To activate the web server at the bus coupler switch off the power supply of the *MECHATROLINK-III* coupler.
2. ➤ Set the *Operating mode 'C'* (position 1) at the address switch to 1: *Maintenance mode*.
3. ➤ At the address switch, set the *MECHATROLINK-III* address as the IP address. For the IP address 192.168.1.1 set the switch '1' (position 3) to 1 and the switches '2' ... '32' (pos. 4 ... 8) to 0. ↪ *Chap. 3.2.3 'Address switch' page 50*
4. ➤ Switch on the power supply of the *MECHATROLINK-III* coupler.
 - ⇒ The coupler is now in maintenance mode. The integrated web server may be accessed via the following IP address:
 - Subnet mask: 255.255.255.0
 - IP address: 192.168.1.1

Setting Parameters

1. ➤ Start your web browser and open the web side of the *MECHATROLINK-III* coupler.
2. ➤ Here you can change default parameters of the modules, if necessary. For this, click at '*Parameter*' of the according module.
3. ➤ To save the configuration, click at the *MECHATROLINK-III* coupler and save the configuration via the dialog '*Configuration*'.
4. ➤ Close you web browser.
5. ➤ PowerOFF and disconnect your *MECHATROLINK-III* coupler

Configuration of the MP3000 series

1. ➤ Define I/O area to SVC definition as multi slave by using the station number with the following parameters:

...	ADR	ExADR	VENDOR	DEVICE	PROFILE	BYTE	...
	03h	00h	***Vendor	Wild Card Device	Standard I/O	16	
	03h	01h	***Vendor	Wild Card Device	Standard I/O	64	

2. ➤ Save the MPE720 project

Starting communication

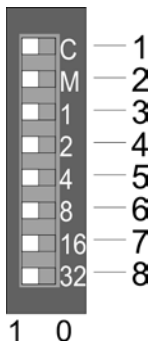

1. ➤ Set the *Operating mode 'C'* (position 1) at the address switch to 0: *Standard mode*.
2. ➤ For the *MECHATROLINK-III* address 03h set switch '1' (position 3) and switch '2' (position 4) to 1. Leave the switches '4' ... '32' (position 5 ... 8) at 0. ↪ *Chap. 3.2.3 'Address switch' page 50*
3. ➤ Connect the *MECHATROLINK-III* coupler with the MP3000 by a *MECHATROLINK-III* cable.
4. ➤ PowerON the *MECHATROLINK-III* coupler and the MP3000.
5. ➤ Transfer the MPE720 project to the MP3000.
6. ➤ Check the connection status and the I/O data transfer.

Supported SVC I/O commands

Code	Command name	Coupler Station	Peripheral Station
0	Data I/O	Yes	Yes
1	Read alarms/warnings	Yes	Yes
2	Clear alarms/warnings	Yes	Yes
3	Read parameters	-	-
4	Write parameters	-	-
5	Read non-volatile parameters	-	-
6	Write non-volatile parameters	-	-
7	Read memory	-	-
8	Write memory	-	-
9 ... 14	Reserved	-	-
15	Communication reset	Yes	Yes
16	Network reset	Yes	Yes

4.10.2 Sequence of coupler commands

4.10.2.1 Read diagnostic data - 16 byte from slot 1

Proceeding

1. **1.** Confirm coupler command = 0 and response command = 0
⇒ Response: 0
2. **2.** Read byte 1 at the same MECHATROLINK-III cycle:
 - Set command data
 - Byte size: Byte 4 ... 5: 8
 - Reserved: Byte 6 .. 7: 0
 - Offset: Byte 8 ... 11: 0x8000 8520
 - Set coupler command 1 (read memory)
 - Set command ID = 0
3. **3.** Wait until response command = 1 (read memory) and command ID = 0
4. **4.** Confirm response data (byte 4 ... 11)
5. **5.** Read byte 2 at the same MECHATROLINK-III cycle:
 - Set command data
 - Byte size: Byte 4 ... 5: 8
 - Reserved: Byte 6 ... 7: 0
 - Offset: Byte 8 ... 11: 0x8000 8528
 - Set coupler command = 1 (read memory)
 - Set command ID = 1
6. **6.** Wait until response command = 1 (read memory) and command ID = 1
7. **7.** Confirm response data (byte 4 ... 11)
8. **8.** NOP at the same MECHATROLINK-III cycle:
 - Set coupler command = 0 (NOP)
 - Set command ID = 0
9. **9.** Wait until response command = 0 (NOP) and command ID = 0

4.10.2.2 Reset diagnostic data - reset slot 1 and slot 2

Proceeding

1. **1.** Confirm coupler command = 0 and response command = 0
2. **2.** For slot 1 at the same MECHATROLINK-III cycle:
 - Set command data
 - Slot number: Byte 4 ... 5: 1
 - Set coupler command = 2 (reset diagnostic data)
 - Set command ID = 0
3. **3.** Wait until response command = 2 (reset diagnostic data) and command ID = 0
4. **4.** Confirm response data (byte 4 ... 5)
5. **5.** For slot 2 at the same MECHATROLINK-III cycle:
 - Set command data
 - Slot number: Byte 4 ... 5: 2
 - Set coupler command = 2 (Reset diagnostic data)
 - Set command ID = 1
6. **6.** Wait until response command = 2 (reset diagnostic data) and command ID = 1
7. **7.** Confirm response data (byte 4 ... 5)

8. → NOP at the same MECHATROLINK-III cycle:
 - Set coupler command = 0 (NOP)
 - Set command ID = 0
9. → Wait until response command = 0 (NOP) and command ID = 1

4.10.3 Communication structure

Standard Operation

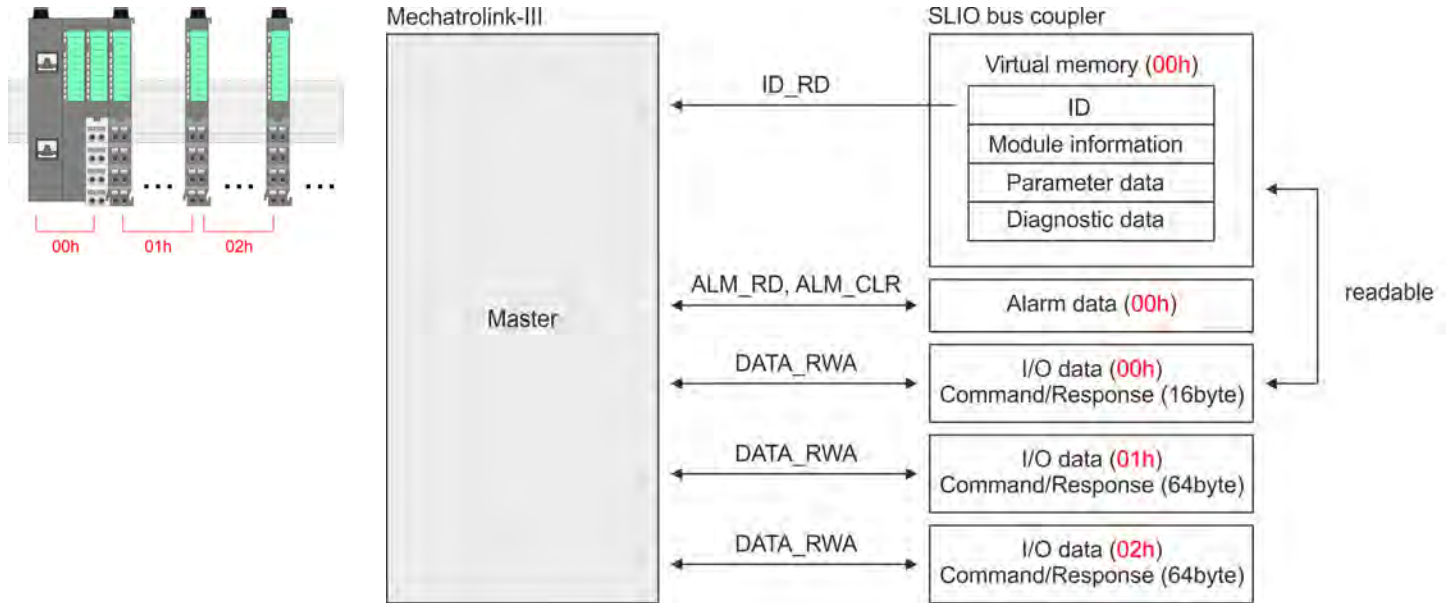

Appendix

Content

A	History of changes.....	103
----------	--------------------------------	------------

A History of changes

Rev.	Changes
18-42	The manual was created.
19-40	General <ul style="list-style-type: none">■ CI adjustment was made. Chapter "Basics and Mounting" <ul style="list-style-type: none">■ Description "Hardware revision" was added. Chapter "Deployment" <ul style="list-style-type: none">■ Description of "Accessing the System SLIO" was changed.
22-30	CI adjustment was made. Chapter "General" <ul style="list-style-type: none">■ The chapter was restructured. Chapter "Basics and Mounting" <ul style="list-style-type: none">■ Description "Industrial security and installation guidelines" was changed.■ Description "Use in difficult operating conditions" was added.