

VIPA System SLIO IM 053IP

IM | 053-1IP00 | Manual

HB300 | IM | 053-1IP00 | GB | 15-33

VIPA GmbH
Ohmstr. 4
91074 Herzogenaurach
Telephone: +49 9132-744-0
Fax: +49 9132-744-1864
Email: info@vipa.com
Internet: www.vipa.com

Table of contents

1	General	4
1.1	Copyright © VIPA GmbH	4
1.2	About this manual.....	5
1.3	Safety information.....	6
2	Basics and Assembly	8
2.1	Safety information for users.....	8
2.2	System conception.....	9
2.3	Dimensions.....	13
2.4	Installation.....	15
2.5	Demounting and module exchange.....	19
2.6	Wiring.....	23
2.7	Trouble shooting - LEDs.....	27
2.8	Installation guidelines.....	27
2.9	General data.....	30
3	Hardware description	32
3.1	Properties.....	32
3.2	Structure.....	33
3.2.1	Interfaces.....	33
3.2.2	Address switch.....	34
3.2.3	LEDs.....	35
3.3	Technical data.....	36
4	Deployment	38
4.1	Basics EtherNet/IP.....	38
4.2	Basics - IP address and subnet.....	39
4.3	Setting the IP address.....	41
4.4	Operating modes.....	42
4.5	Web server.....	43
4.6	Accessing the System SLIO.....	48
4.6.1	Overview.....	48
4.6.2	Accessing I/O area	49
4.6.3	Accessing the parameter data.....	51
4.6.4	Accessing diagnostics data.....	53
4.7	Deployment of FORWARD_OPEN.....	53
4.7.1	Command IDs.....	54
4.8	EtherNet/IP - Objects.....	58
4.8.1	Standardized EtherNet/IP Objects.....	58
4.8.2	VIPA specific EtherNet/IP objects.....	59
4.9	Examples.....	67
4.9.1	Configuration at a Yaskawa MWIEC scanner.....	67
4.9.2	Configuration at a Rockwell scanner.....	74

1 General

1.1 Copyright © VIPA GmbH

All Rights Reserved

This document contains proprietary information of VIPA and is not to be disclosed or used except in accordance with applicable agreements.

This material is protected by the copyright laws. It may not be reproduced, distributed, or altered in any fashion by any entity (either internal or external to VIPA), except in accordance with applicable agreements, contracts or licensing, without the express written consent of VIPA and the business management owner of the material.

For permission to reproduce or distribute, please contact: VIPA, Gesellschaft für Visualisierung und Prozessautomatisierung mbH Ohmstraße 4, D-91074 Herzogenaurach, Germany

Tel.: +49 9132 744 -0

Fax.: +49 9132 744-1864

E-Mail: info@vipa.de

<http://www.vipa.com>



Every effort has been made to ensure that the information contained in this document was complete and accurate at the time of publishing. Nevertheless, the authors retain the right to modify the information.

This customer document describes all the hardware units and functions known at the present time. Descriptions may be included for units which are not present at the customer site. The exact scope of delivery is described in the respective purchase contract.

CE Conformity Declaration

Hereby, VIPA GmbH declares that the products and systems are in compliance with the essential requirements and other relevant provisions. Conformity is indicated by the CE marking affixed to the product.

Conformity Information

For more information regarding CE marking and Declaration of Conformity (DoC), please contact your local VIPA customer service organization.

Trademarks

VIPA, SLIO, System 100V, System 200V, System 300V, System 300S, System 400V, System 500S and Commander Compact are registered trademarks of VIPA Gesellschaft für Visualisierung und Prozessautomatisierung mbH.

SPEED7 is a registered trademark of profichip GmbH.

SIMATIC, STEP, SINEC, TIA Portal, S7-300 and S7-400 are registered trademarks of Siemens AG.

Microsoft and Windows are registered trademarks of Microsoft Inc., USA.

Portable Document Format (PDF) and Postscript are registered trademarks of Adobe Systems, Inc.

All other trademarks, logos and service or product marks specified herein are owned by their respective companies.

Information product support

Contact your local VIPA Customer Service Organization representative if you wish to report errors or questions regarding the contents of this document. If you are unable to locate a customer service centre, contact VIPA as follows:

VIPA GmbH, Ohmstraße 4, 91074 Herzogenaurach, Germany

Telefax: +49 9132 744-1204

E-Mail: documentation@vipa.de

Technical support

Contact your local VIPA Customer Service Organization representative if you encounter problems with the product or have questions regarding the product. If you are unable to locate a customer service centre, contact VIPA as follows:

VIPA GmbH, Ohmstraße 4, 91074 Herzogenaurach, Germany

Tel.: +49 9132 744-1150 (Hotline)

E-Mail: support@vipa.de

1.2 About this manual**Objective and contents**

This manual describes the IM 053-1IP00 of the System SLIO from VIPA. It contains a description of the structure, project engineering and deployment. This manual is part of the documentation package with order number VIPA HB300E_IM and relevant for:

Product	Order no.	as of state:	
		HW	FW
IM 053IP	053-1IP00	01	V2.10

Target audience

The manual is targeted at users who have a background in automation technology.

Structure of the manual

The manual consists of chapters. Every chapter provides a self-contained description of a specific topic.

- Guide to the document** The following guides are available in the manual:
- An overall table of contents at the beginning of the manual
 - References with page numbers
- Availability** The manual is available in:
- printed form, on paper
 - in electronic form as PDF-file (Adobe Acrobat Reader)
- Icons Headings** Important passages in the text are highlighted by following icons and headings:

**DANGER!**

Immediate or likely danger. Personal injury is possible.

**CAUTION!**

Damages to property is likely if these warnings are not heeded.



Supplementary information and useful tips.

1.3 Safety information

Applications conforming with specifications

The system is constructed and produced for:

- communication and process control
- industrial applications
- operation within the environmental conditions specified in the technical data
- installation into a cubicle

**DANGER!**

This device is not certified for applications in
– in explosive environments (EX-zone)

Documentation

The manual must be available to all personnel in the

- project design department
- installation department
- commissioning
- operation

**CAUTION!**

The following conditions must be met before using or commissioning the components described in this manual:

- Hardware modifications to the process control system should only be carried out when the system has been disconnected from power!
- Installation and hardware modifications only by properly trained personnel.
- The national rules and regulations of the respective country must be satisfied (installation, safety, EMC ...)

Disposal

National rules and regulations apply to the disposal of the unit!

2 Basics and Assembly

2.1 Safety information for users

Handling of electrostatic sensitive modules

VIPA modules make use of highly integrated components in MOS-Technology. These components are extremely sensitive to over-voltages that can occur during electrostatic discharges. The following symbol is attached to modules that can be destroyed by electrostatic discharges.



The Symbol is located on the module, the module rack or on packing material and it indicates the presence of electrostatic sensitive equipment. It is possible that electrostatic sensitive equipment is destroyed by energies and voltages that are far less than the human threshold of perception. These voltages can occur where persons do not discharge themselves before handling electrostatic sensitive modules and they can damage components thereby, causing the module to become inoperable or unusable. Modules that have been damaged by electrostatic discharges can fail after a temperature change, mechanical shock or changes in the electrical load. Only the consequent implementation of protection devices and meticulous attention to the applicable rules and regulations for handling the respective equipment can prevent failures of electrostatic sensitive modules.

Shipping of modules

Modules must be shipped in the original packing material.

Measurements and alterations on electrostatic sensitive modules

When you are conducting measurements on electrostatic sensitive modules you should take the following precautions:

- Floating instruments must be discharged before use.
- Instruments must be grounded.

Modifying electrostatic sensitive modules you should only use soldering irons with grounded tips.



CAUTION!

Personnel and instruments should be grounded when working on electrostatic sensitive modules.

2.2 System conception

Overview

System SLIO is a modular automation system for assembly on a 35mm mounting rail. By means of the peripheral modules with 2, 4 or 8 channels this system may properly be adapted matching to your automation tasks. The wiring complexity is low, because the supply of the DC 24V power section is integrated to the backplane bus and defective modules may be replaced with standing wiring. By deployment of the power modules in contrasting colours within the system, further isolated areas may be defined for the DC 24V power section supply, respectively the electronic power supply may be extended with 2A.

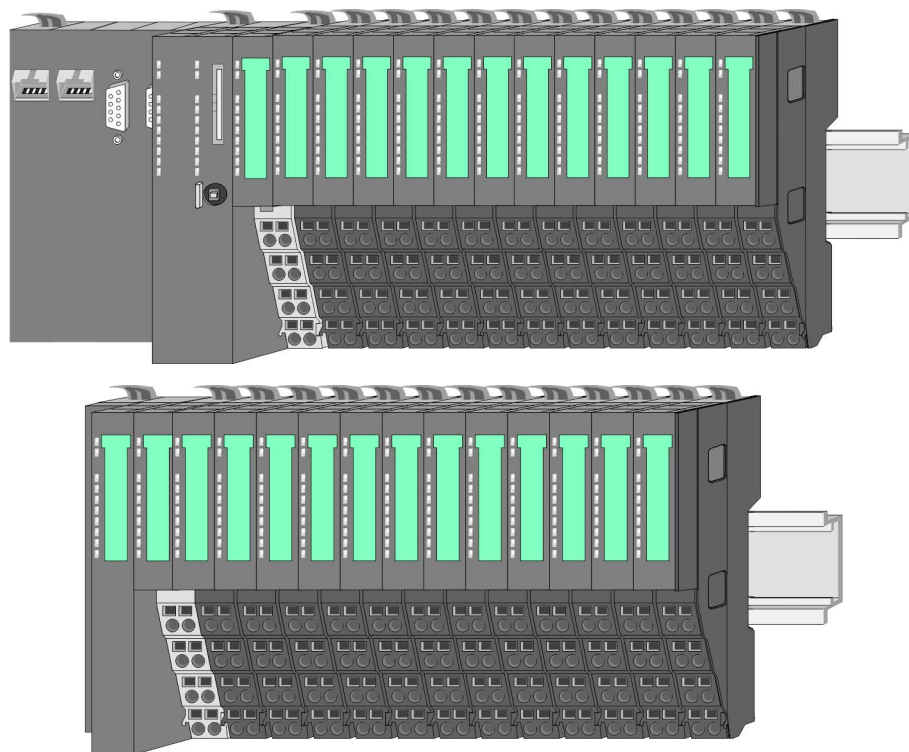

Components

- CPU (head module)
- Bus coupler (head module)
- Periphery modules
- Power modules
- Accessories



CAUTION!

Only modules of VIPA may be combined. A mixed operation with third-party modules is not allowed!

System conception

CPU



With a CPU, CPU electronic and power module are integrated to one casing. As head module via the integrated power module for power supply the CPU electronic is supplied as well as the electronic of the connected periphery modules. The DC 24 power section supply for the linked periphery modules is established via a further connection at the power module. By installing of up to 64 periphery modules at the CPU, these are electrically connected, this means these are assigned to the backplane bus, the electronic modules are power supplied and each periphery module is connected to the DC 24V power section supply.



CAUTION!

CPU part and power module of a CPU may not be separated! Here you may only exchange the electronic module!

Bus coupler

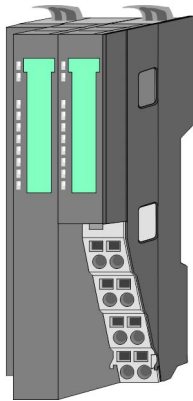

With a bus coupler bus interface and power module are integrated to one casing. With the bus interface you get access to a subordinated bus system. As head module via the integrated power module for power supply the bus interface is supplied as well as the electronic of the connected periphery modules. The DC 24 power section supply for the linked periphery modules is established via a further connection at the power module. By installing of up to 64 periphery modules at the bus coupler, these are electrically connected, this means these are assigned to the backplane bus, the electronic modules are power supplied and each periphery module is connected to the DC 24V power section supply.



CAUTION!

Bus interface and power module of the bus coupler may not be separated! Here you may only exchange the electronic module!

Periphery modules

Each periphery module consists of a *terminal* and an *electronic module*.

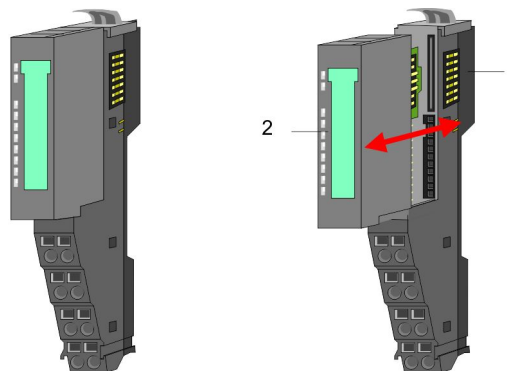

- 1 Terminal module
- 2 Electronic module

Terminal module

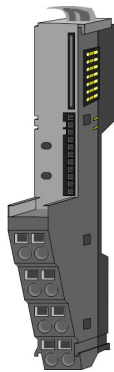

The *terminal module* serves to carry the electronic module, contains the backplane bus with power supply for the electronic, the DC 24V power section supply and the staircase-shaped terminal for wiring. Additionally the terminal module has a locking system for fixing at a mounting rail. By means of this locking system your SLIO system may be assembled outside of your switchgear cabinet to be later mounted there as whole system.

Electronic module

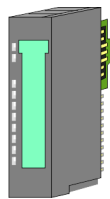

The functionality of a SLIO periphery module is defined by the *electronic module*, which is mounted to the terminal module by a safe sliding mechanism. With an error the defective module may be exchanged for a functional module with standing installation.

At the front side there are LEDs for status indication. For simple wiring each module shows a corresponding connection diagram at the front and at the side.

Power module

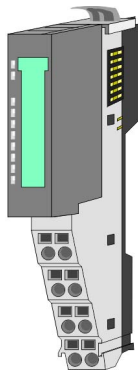

In the System SLIO the power supply is established by power modules. These are either integrated to the head module or may be installed between the periphery modules. Depending on the power module isolated areas of the DC 24V power section supply may be defined respectively the electronic power supply may be extended with 2A. For better recognition the colour of the power modules are contrasting to the periphery modules.

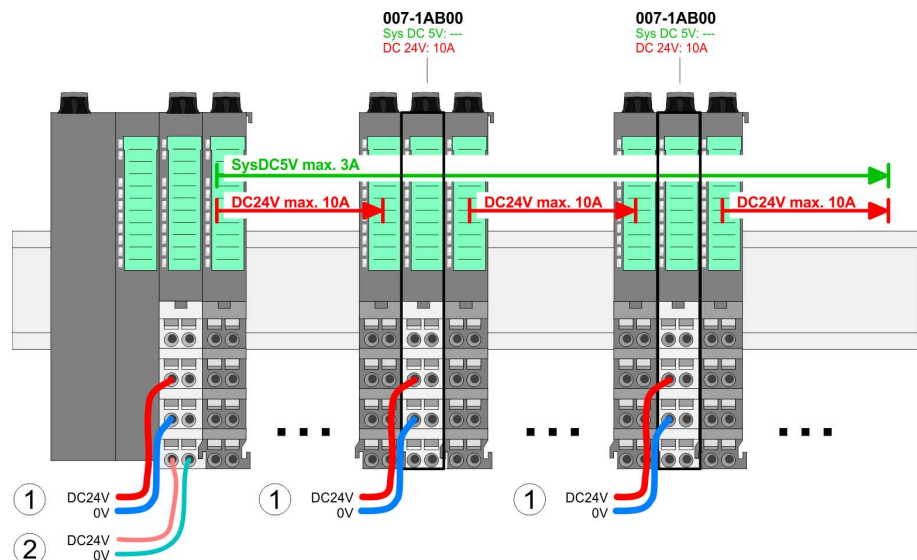

System conception

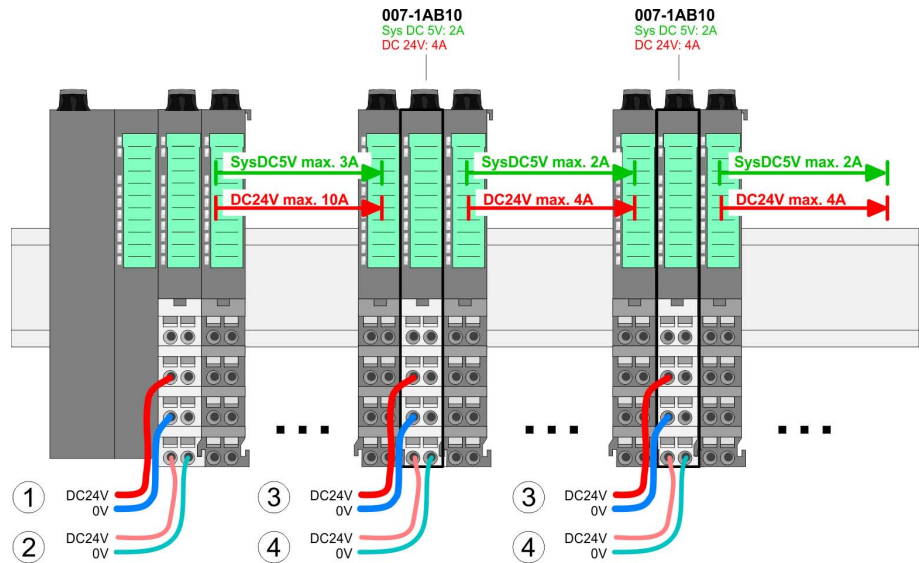

- (1) DC 24V for power section supply I/O area (max. 10A)
- (2) DC 24V for electronic power supply bus coupler and I/O area
- (3) DC 24V for power section supply I/O area (max. 4A)
- (4) DC 24V for electronic power supply I/O area

Accessories

Shield bus carrier



The shield bus carrier (order no. 000-0AB00) serves to carry the shield bus (10mm x 3mm) to connect cable shields. Shield bus carriers, shield bus and shield fixings are not in the scope of delivery. They are only available as accessories. The shield bus carrier is mounted underneath the terminal of the terminal module. With a flat mounting rail for adaption to a flat mounting rail you may remove the spacer of the shield bus carrier.

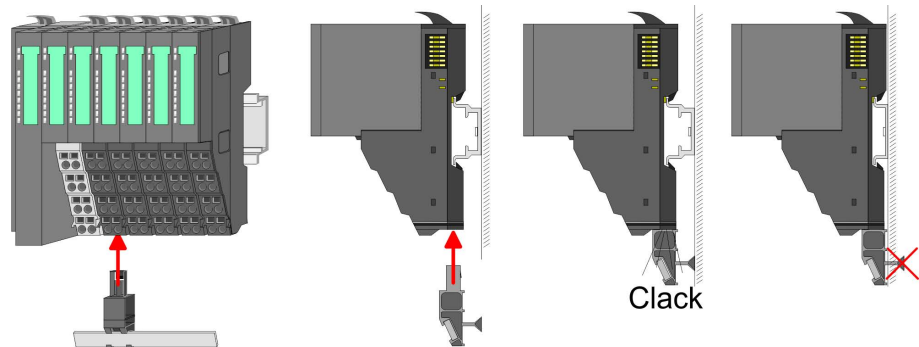

Bus cover

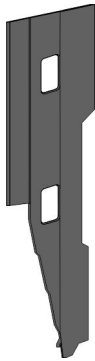

With each bus coupler, to protect the backplane bus connectors, there is a mounted bus cover in the scope of delivery. You have to remove the bus cover of the bus coupler before mounting a SLIO module. For the protection of the backplane bus connector you always have to mount the bus cover at the last module of your system again.

The bus cover has the order no. 000-0AA00.

Coding pins



There is the possibility to fix the assignment of electronic and terminal module. Here coding pins (order number 000-0AC00) from VIPA can be used. The coding pin consists of a coding jack and a coding plug. By combining electronic and terminal module with coding pin, the coding jack remains in the electronic module and the coding plug in the terminal module. This ensures that after replacing the electronics module just another electronic module can be plugged with the same encoding.

2.3 Dimensions

Dimensions CPU

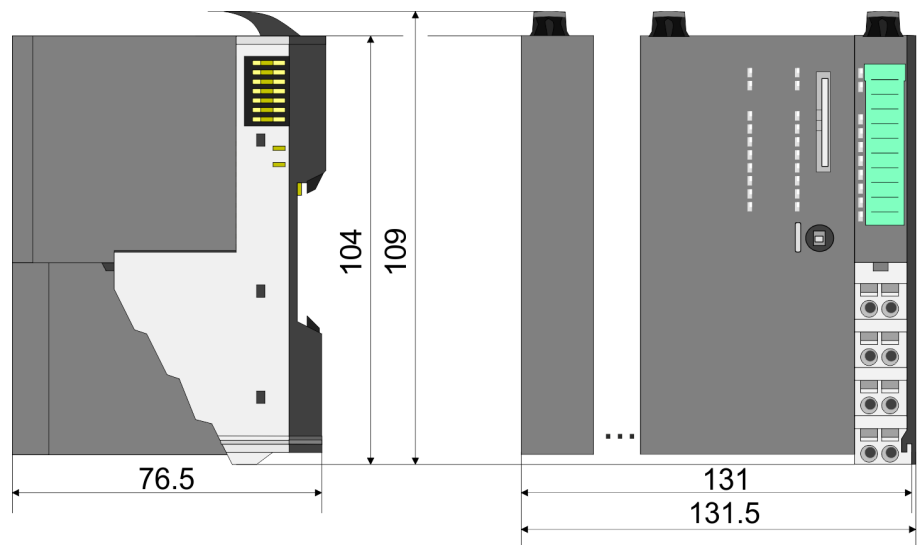

Dimensions

Dimensions bus coupler

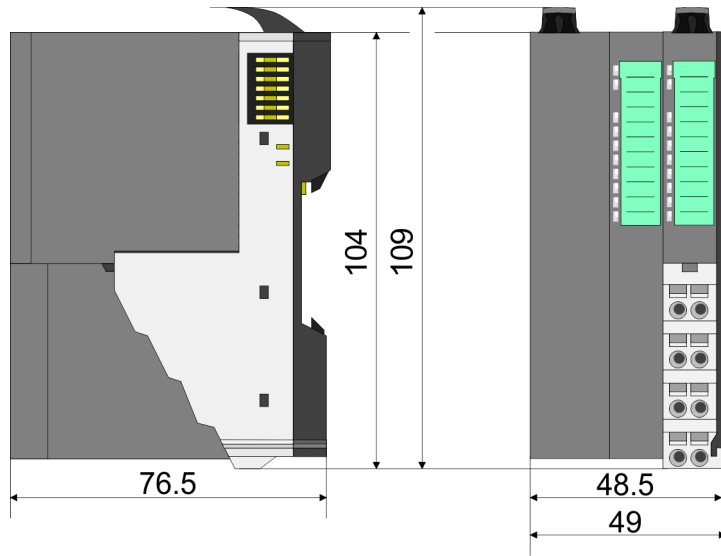

Dimensions periphery module

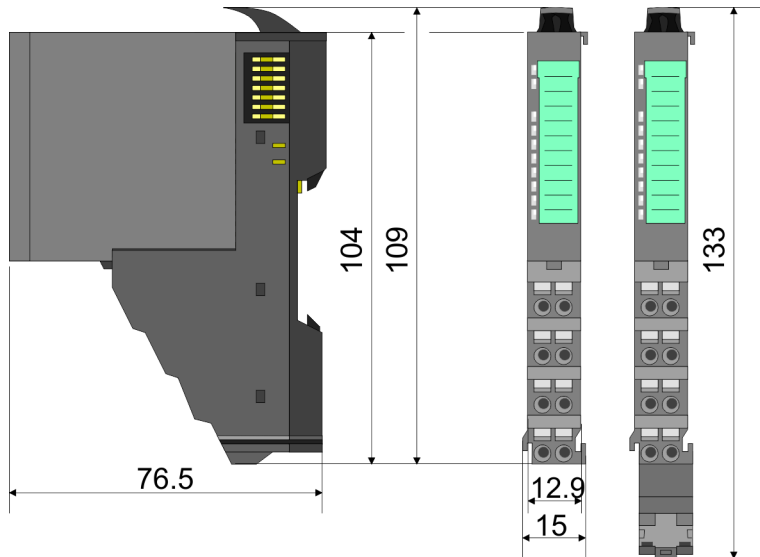

Dimensions electronic module

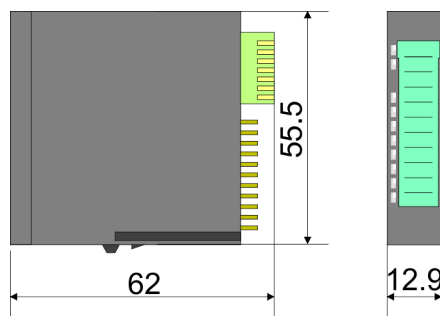

Dimensions in mm

2.4 Installation

Functional principle

There is a locking lever at the top side of the terminal module. For mounting and demounting this locking lever is to be turned upwards until this engages audible. Now the module may be pulled forward. For mounting plug the module to the module installed before and push the module to the mounting rail guided by the strips at the upper and lower side of the module. The module is fixed to the mounting rail by pushing downward the locking lever. The modules may either separately be mounted to the mounting rail or as block. Here is to be considered that each locking lever is opened.

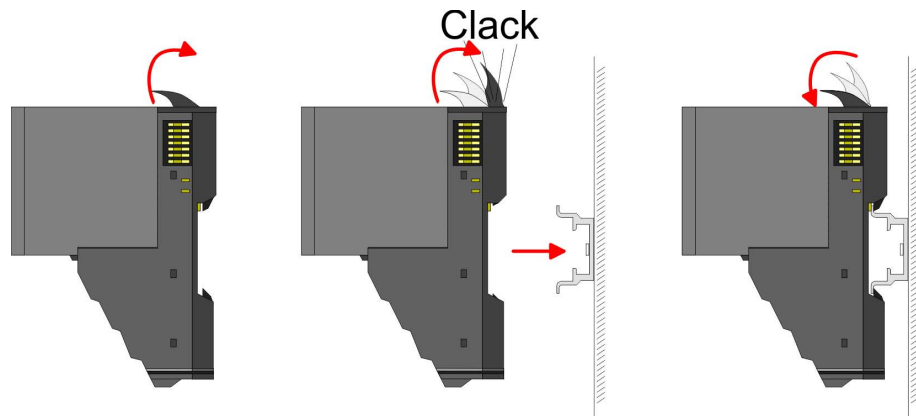

For the exchange of a electronic module, the electronic module may be pulled forward after pressing the unlocking lever at the lower side of the module. For installation plug the electronic module guided by the strips at the lower side until this engages audible to the terminal module.

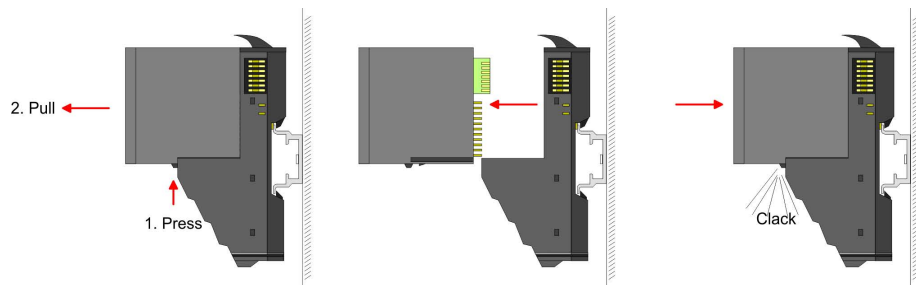

Coding



There is the possibility to fix the assignment of electronic and terminal module. Here coding pins (order number 000-0AC00) from VIPA can be used. The coding pin consists of a coding jack and a coding plug. By combining electronic and terminal module with coding pin, the coding jack remains in the electronic module and the coding plug in the terminal module. This ensures that after replacing the electronics module just another electronic module can be plugged with the same encoding.

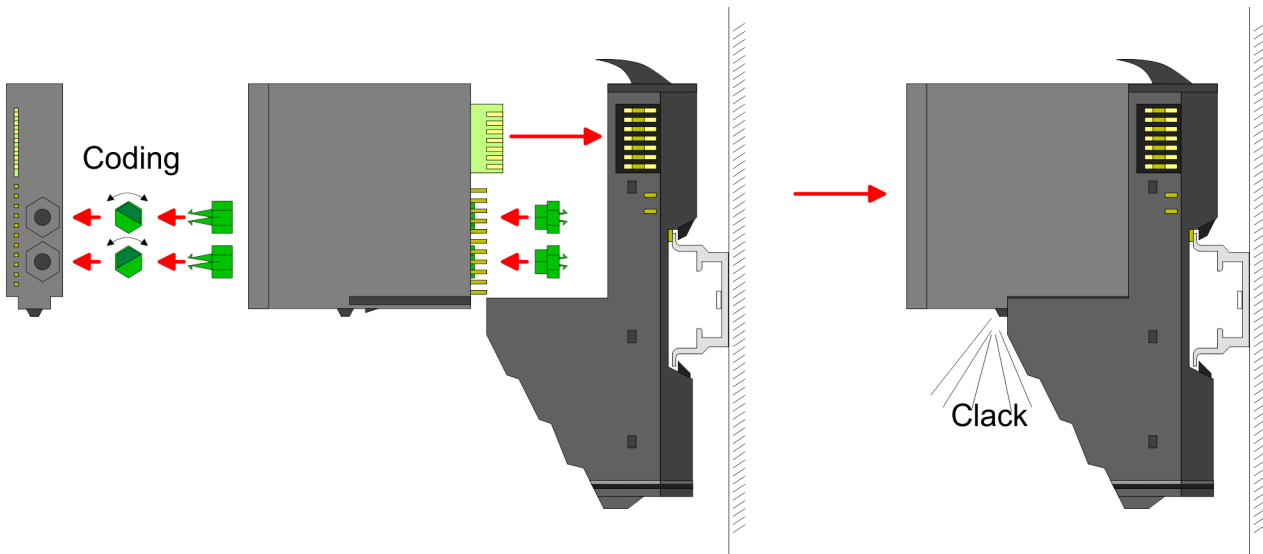

Each electronic module has on its back 2 coding sockets for coding jacks. Due to the characteristics, with the coding jack 6 different positions can be plugged, each. Thus there are 36 possible combinations for coding with the use of both coding sockets.

1. ► Plug, according to your coding, 2 coding jacks in the coding sockets of your electronic module until they lock.
2. ► Now plug the according coding plugs into the coding jacks.
3. ► To fix the coding put both the electronic and terminal module together until they lock.



CAUTION!

Please consider that when replacing an already coded electronic module, this is always be replaced by an electronic module with the same coding.

Even with an existing coding on the terminal module, you can plug an electronic module without coding. The user is responsible for the correct usage of the coding pins. VIPA assumes no liability for incorrectly attached electronic modules or for damages which arise due to incorrect coding!

Mounting Proceeding

The modules were directly be mounted to the mounting rail and so connected to the backplane bus and the power supply for the electronic and power section. Up to 64 modules may be mounted. Please consider here that the sum current of the electronic power supply does not exceed the maximum value of 3A. By means of the power module 007-1AB10 the current of the electronic power supply may be expanded with 2A. ↪ *Chapter 2.6 'Wiring' on page 23*

Mounting rail

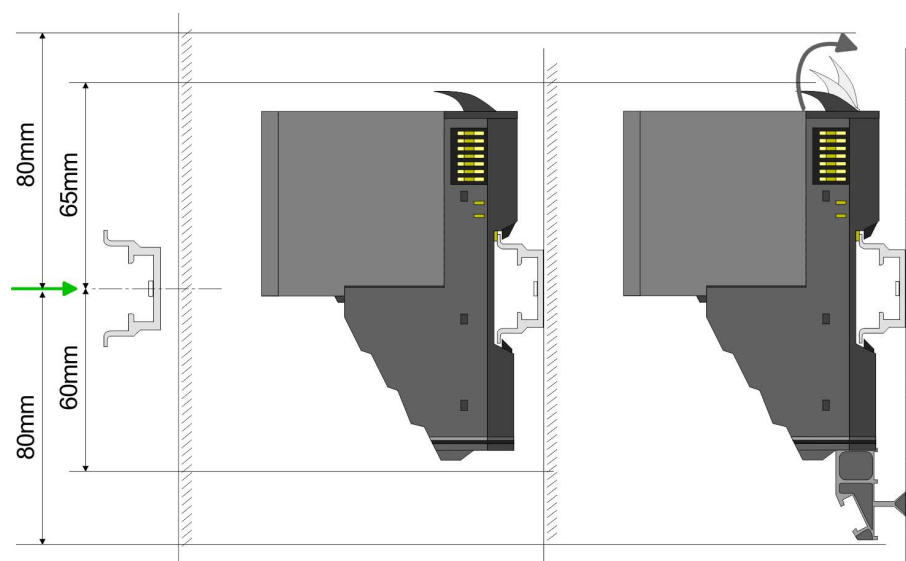

- ➔ Mount the mounting rail! Please consider that a clearance from the middle of the mounting rail of at least 80mm above and 60mm below, respectively 80mm by deployment of shield bus carriers, exist.

Mounting Head module (e.g. bus coupler)

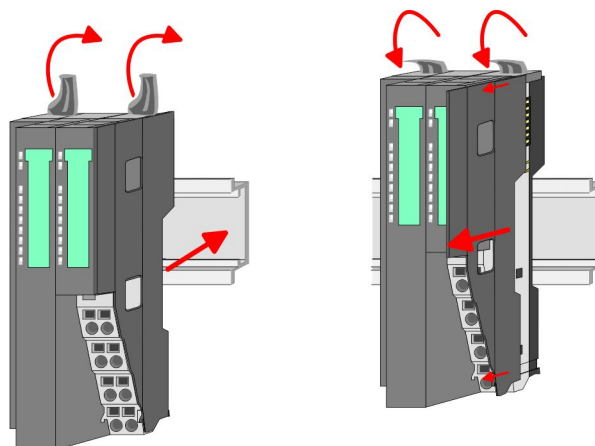

- ➔ Start at the left side with the head module (e.g. bus coupler). For this turn both locking lever upwards, put the head module to the mounting rail and turn both locking lever downward.
- ➔ Before mounting the periphery modules you have to remove the bus cover at the right side of the Head module by pulling it forward. Keep the cover for later mounting.

Mounting periphery modules

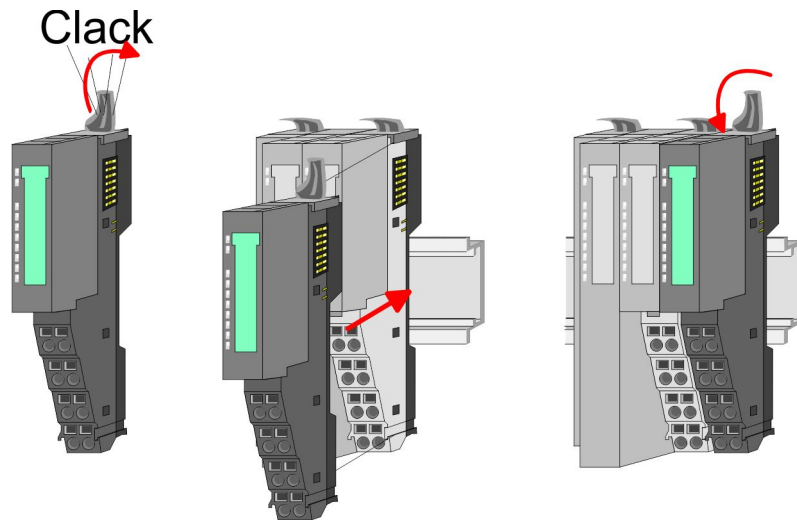

➔ Mount the periphery modules you want.

Mounting the bus cover

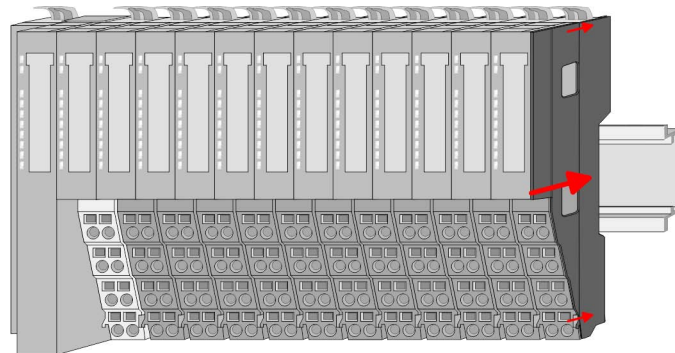

➔ After mounting the whole system, to protect the backplane bus connectors at the last module you have to mount the bus cover, now.

Mounting the bus cover at a clamp module

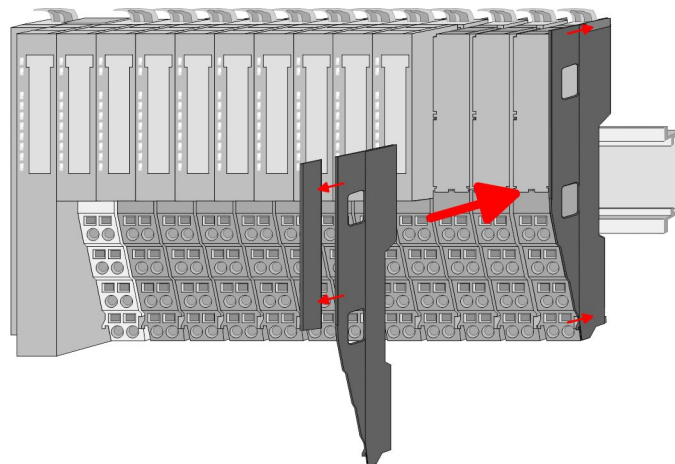

➔ If the last module is a clamp module, for adaptation the upper part of the bus cover is to be removed

Mounting shield bus carrier

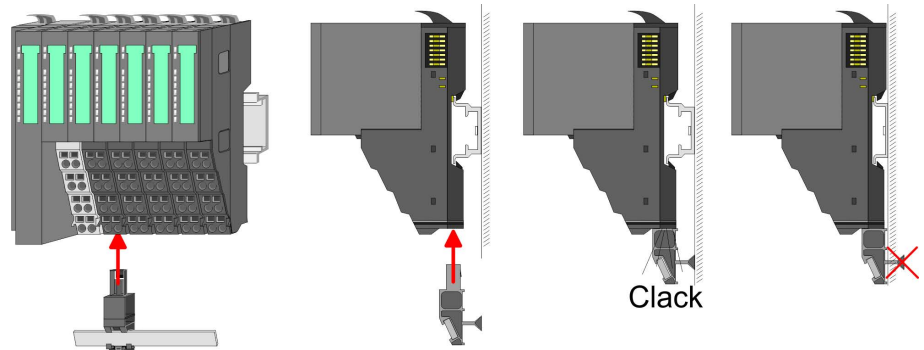

➔ The shield bus carrier (available as accessory) serves to carry the shield bus to connect cable shields. The shield bus carrier is mounted underneath the terminal of the terminal module. With a flat mounting rail for adaption to a flat mounting rail you may remove the spacer of the shield bus carrier.

2.5 Demounting and module exchange

Proceeding

With demounting and exchange of a module, head module (e.g. bus coupler) or a group of modules for mounting reasons you have always to remove the electronic module of the just mounted right module. After the mounting it may be plugged again.

Exchange of an electronic module

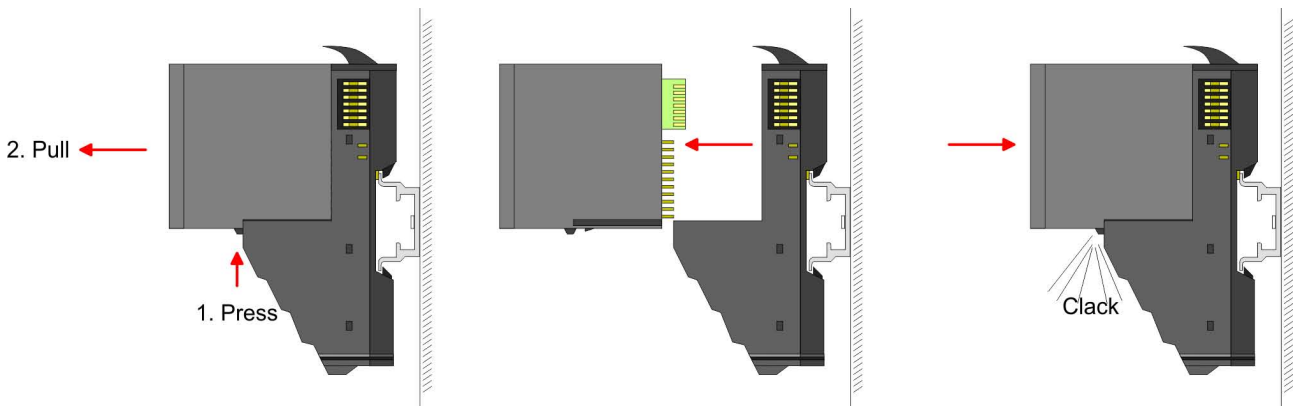

1. ➔ For the exchange of an electronic module, the electronic module may be pulled forward after pressing the unlocking lever at the lower side of the module.
2. ➔ For installation plug the electronic module guided by the strips at the lower side until this engages audible to the terminal module.

Exchange of a module

1. ▶ Remove if exists the wiring. ↪ *Chapter 2.6 'Wiring' on page 23.*

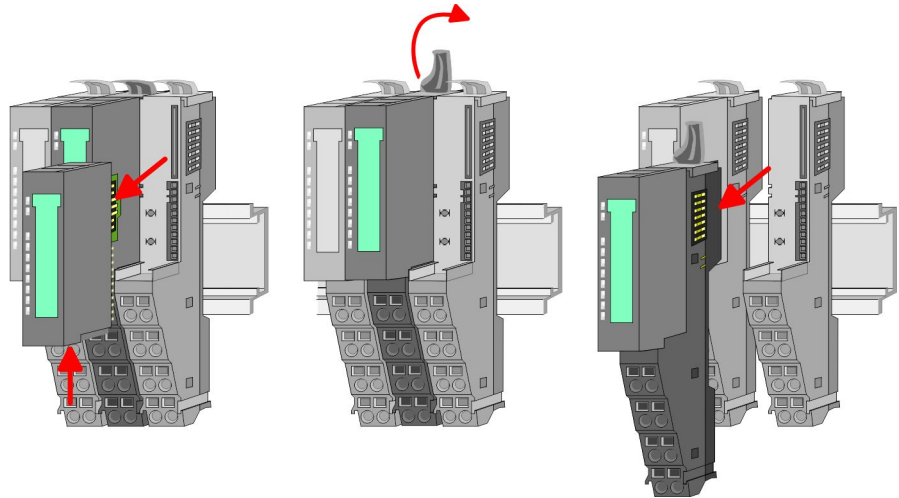

2. ▶ Press the unlocking lever at the lower side of the just mounted right module and pull it forward.
3. ▶ Turn the locking lever of the module to be exchanged upwards.
4. ▶ Pull the module forward.

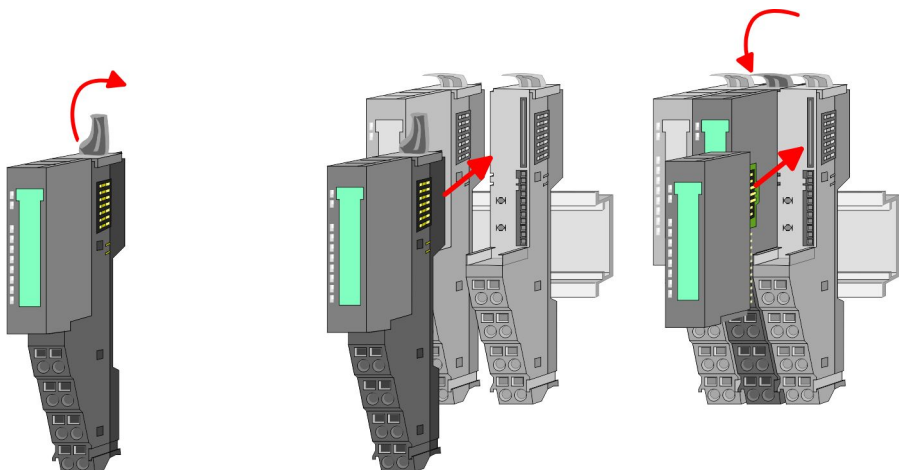

5. ▶ For mounting turn the locking lever of the module to be mounted upwards.
6. ▶ To mount the module put it to the gap between the both modules and push it, guided by the stripes at both sides, to the mounting rail.
7. ▶ Turn the locking lever downward again.
8. ▶ Plug again the electronic module, which you have removed before.

Exchange of a head module (e.g. bus coupler)

**CAUTION!**

Bus interface and power module of a head module may not be separated!

Here you may only exchange the electronic module!

1. ➤ Remove if exists the wiring of the head module. ↪ *Chapter 2.6 'Wiring' on page 23.*

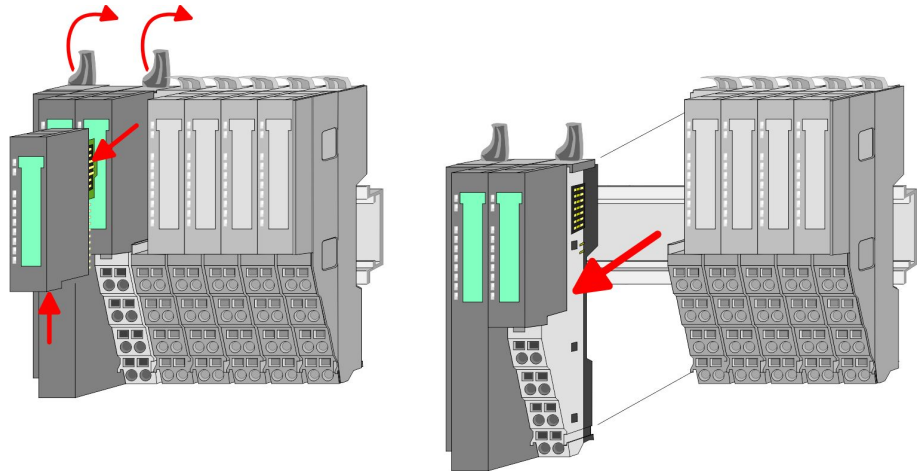

2. ➤ Press the unlocking lever at the lower side of the just mounted right module and pull it forward.
3. ➤ Turn all the locking lever of the head module to be exchanged upwards.
4. ➤ Pull the head module forward.

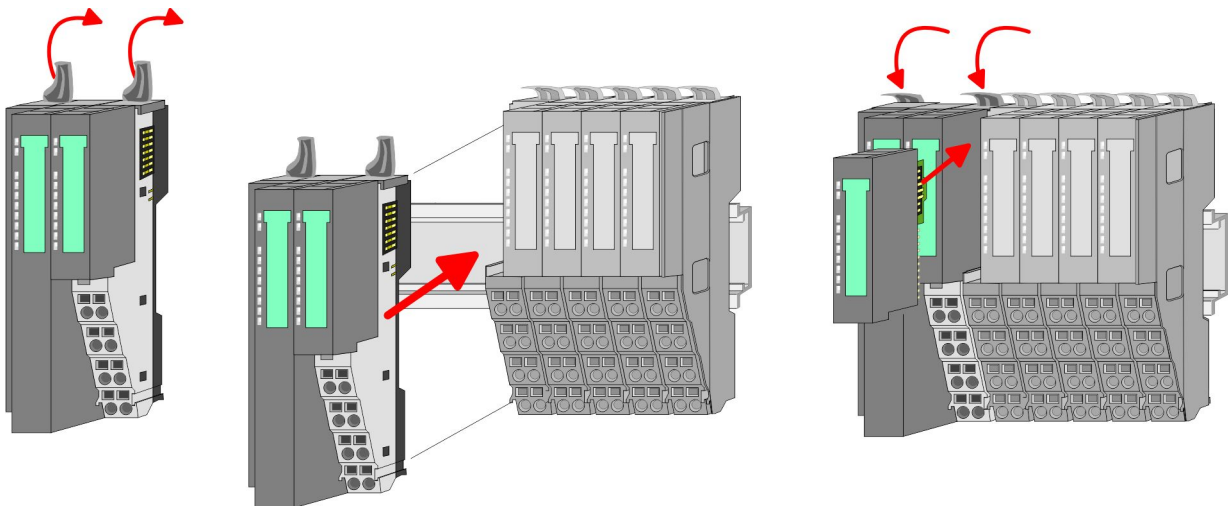

5. ➤ For mounting turn all the locking lever of the head module to be mounted upwards.
6. ➤ To mount the head module put it to the left module and push it, guided by the stripes, to the mounting rail.
7. ➤ Turn all the locking lever downward again.
8. ➤ Plug again the electronic module, which you have removed before.

Exchange of a module group

1. ▶ Remove if exists the wiring of the module group. ↪ *Chapter 2.6 'Wiring' on page 23.*

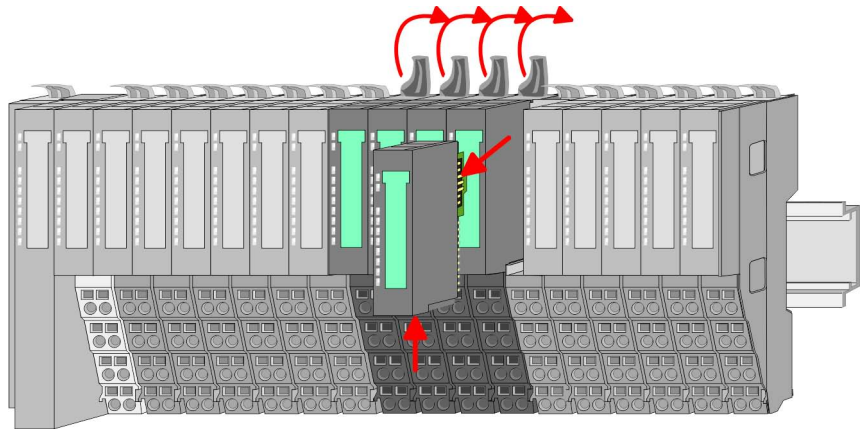

2. ▶ Press the unlocking lever at the lower side of the just mounted right module of the module group and pull it forward.

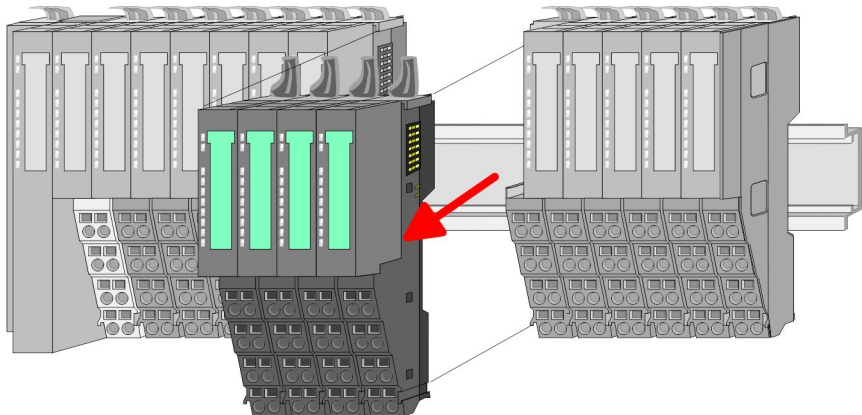

3. ▶ Turn all the locking lever of the module group to be exchanged upwards.

4. ▶ Pull the module group forward.

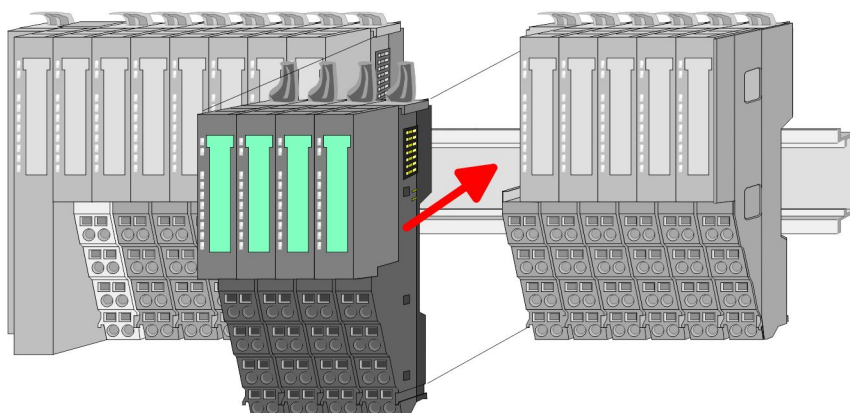
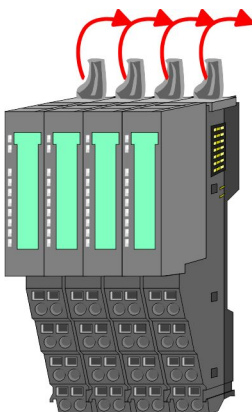

5. ▶ For mounting turn all the locking lever of the module group to be mounted upwards.

6. ▶ To mount the module group put it to the gap between the both modules and push it, guided by the stripes at both sides, to the mounting rail.

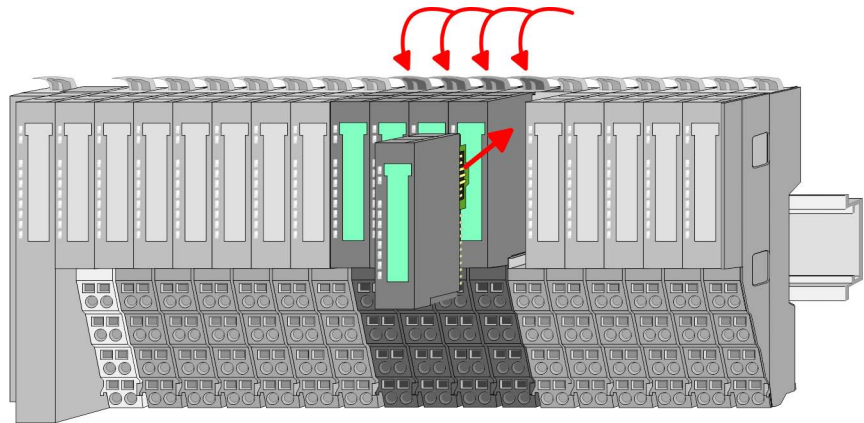

7. Turn all the locking lever downward again.
8. Plug again the electronic module, which you have removed before.

2.6 Wiring Connectors

Terminals with spring clamp technology are used for wiring.

The spring clamp technology allows quick and easy connection of your signal and supply lines.

In contrast to screw terminal connections this type of connection is vibration proof.

Data

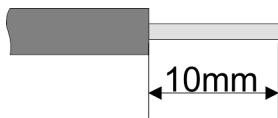

U_{max} : 240V AC / 30V DC

I_{max} : 10A

Cross section: 0.08 ... 1.5mm² (AWG 28 ... 16)

Stripping length: 10mm

Wiring procedure

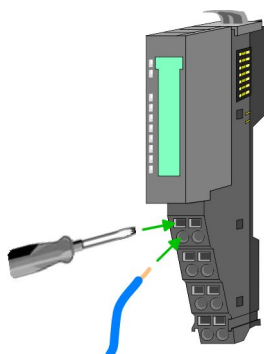
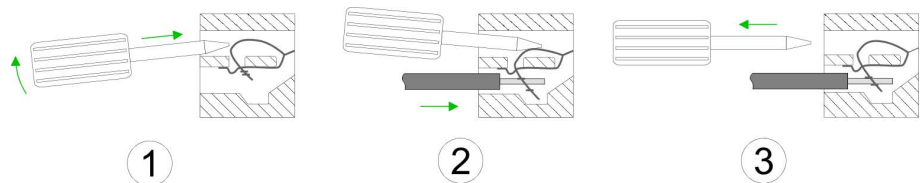

1. Insert a suited screwdriver at an angle into the square opening as shown. Press and hold the screwdriver in the opposite direction to open the contact spring.
2. Insert the stripped end of wire into the round opening. You can use wires with a cross section of 0.08mm² to 1.5mm².
3. By removing the screwdriver, the wire is securely fixed via the spring contact to the terminal.

Standard wiring

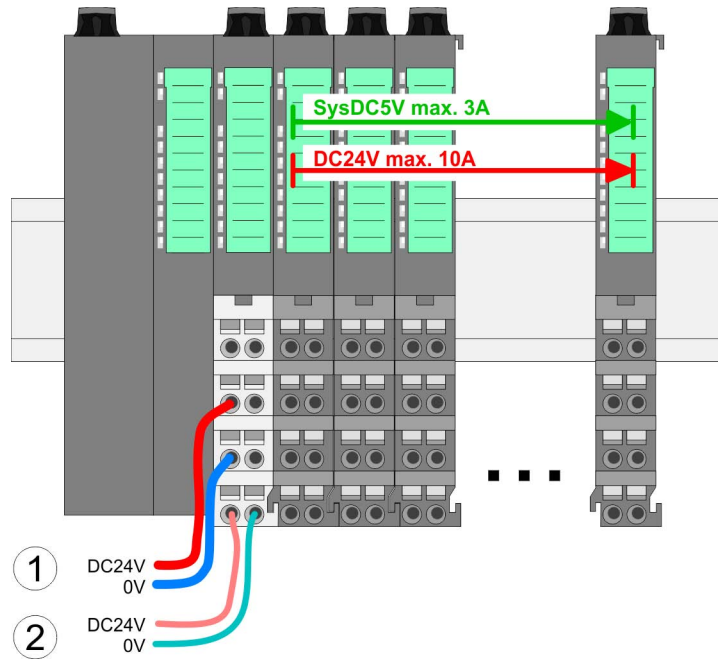

- (1) DC 24V for power section supply I/O area (max 10A)
- (2) DC 24V for electronic power supply bus coupler and I/O area

PM - Power module

For wires with a core cross-section of 0.08mm² up to 1.5mm².

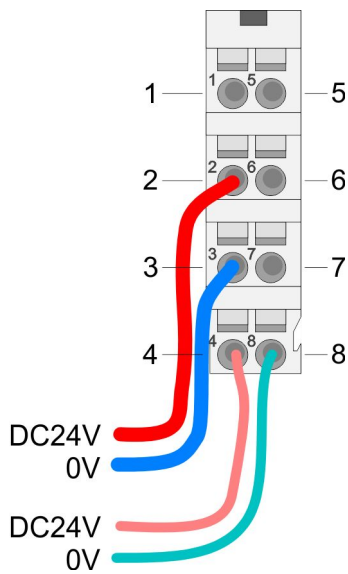

Pos.	Function	Type	Description
1	---	---	not connected
2	DC 24V	I	DC 24V for power section supply
3	0V	I	GND for power section supply
4	Sys DC 24V	I	DC 24V for electronic section supply
5	---	---	not connected
6	DC 24V	I	DC 24V for power section supply
7	0V	I	GND for power section supply
8	Sys 0V	I	GND for electronic section supply

I Input



CAUTION!

Since the power section supply is not internally protected, it is to be externally protected with a fuse, which corresponds to the maximum current. This means max. 10A is to be protected by a 10A fuse (fast) respectively by a line circuit breaker 10A characteristics Z!



The electronic power section supply is internally protected against higher voltage by fuse. The fuse is within the power module. If the fuse releases, its electronic module must be exchanged!

Fusing

- The power section supply is to be externally protected with a fuse, which corresponds to the maximum current. This means max. 10A is to be protected with a 10A fuse (fast) respectively by a line circuit breaker 10A characteristics Z!
- It is recommended to externally protect the electronic power supply for bus coupler and I/O area with a 2A fuse (fast) respectively by a line circuit breaker 2A characteristics Z.
- The electronic power supply for the I/O area of the power module 007-1AB10 should also be externally protected with a 1A fuse (fast) respectively by a line circuit breaker 1A characteristics Z.

State of the electronic power supply via LEDs

After PowerON of the System SLIO the LEDs RUN respectively MF get on so far as the sum current does not exceed 3A.

With a sum current greater than 3A the LEDs may not be activated.

Here the power module with the order number 007-1AB10 is to be placed between the peripheral modules.

Deployment of the power modules

If the 10A for the power section supply is no longer sufficient, you may use the power module from VIPA with the order number 007-1AB00. So you have also the possibility to define isolated groups.

The power module with the order number 007-1AB10 is to be used if the 3A for the electronic power supply at the backplane bus is no longer sufficient. Additionally you get an isolated group for the DC 24V power section supply with 4A.

By placing the power module 007-1AB10 at the following backplane bus modules may be placed with a sum current of max. 2A. Afterwards the power module 007-1AB10 is to be placed again. To secure the power supply, the power modules may be mixed used.

Power module 007-1AB00

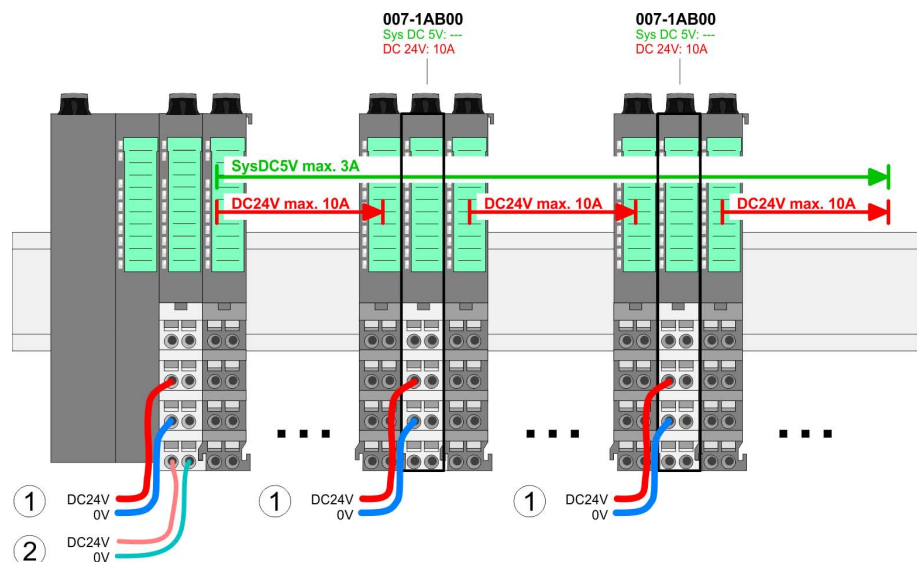

**Power module
007-1AB10**

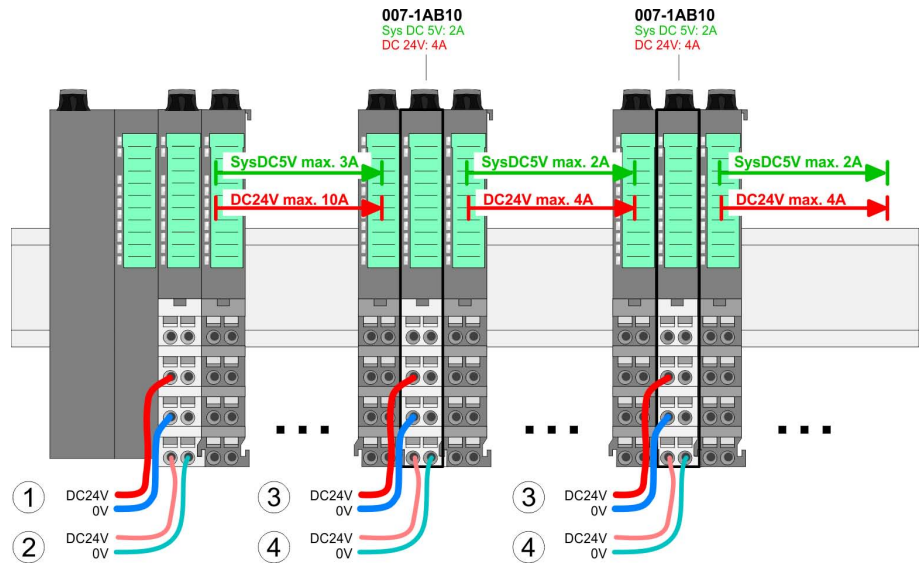

- (1) DC 24V for power section supply I/O area (max. 10A)
- (2) DC 24V for electronic power supply bus coupler and I/O area
- (3) DC 24V for power section supply I/O area (max. 4A)
- (4) DC 24V for electronic power supply I/O area

Shield attachment

To attach the shield the mounting of shield bus carriers are necessary.

The shield bus carrier (available as accessory) serves to carry the shield bus to connect cable shields.

The shield bus carrier is mounted underneath the terminal of the terminal module. With a flat mounting rail for adaption to a flat mounting rail you may remove the spacer of the shield bus carrier.

After mounting the shield bus carrier with the shield bus, the cables with the accordingly stripped cable screen may be attached and fixed by the shield clamp.

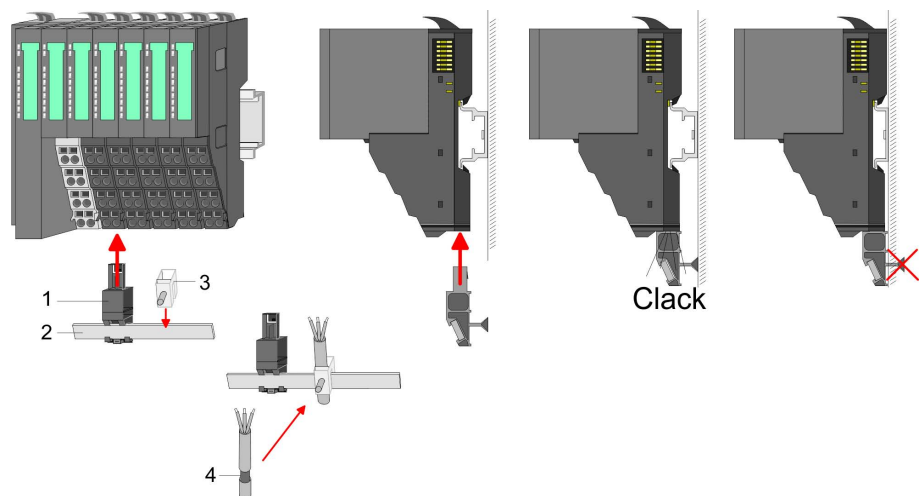

- 1 Shield bus carrier
- 2 Shield bus (10mm x 3mm)
- 3 Shield clamp
- 4 Cable shield

2.7 Trouble shooting - LEDs

General

Each module has the LEDs RUN and MF on its front side. Errors or incorrect modules may be located by means of these LEDs.

In the following illustrations flashing LEDs are marked by ☼.

Sum current of the electronic power supply exceeded

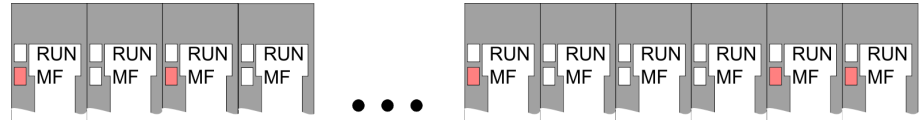

Behaviour: After PowerON the RUN LED of each module is off and the MF LED of each module is sporadically on.

Reason: The maximum current for the electronic power supply is exceeded.

Remedy: As soon as the sum current of the electronic power supply is exceeded, always place the power module 007-1AB10. ☞ Chapter 2.6 'Wiring' on page 23.

Error in configuration

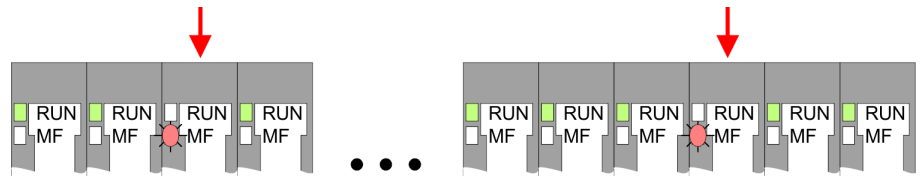

Behaviour: After PowerON the MF LED of one module respectively more modules flashes. The RUN LED remains off.

Reason: At this position a module is placed, which does not correspond to the configured module.

Remedy: Match configuration and hardware structure.

Module failure

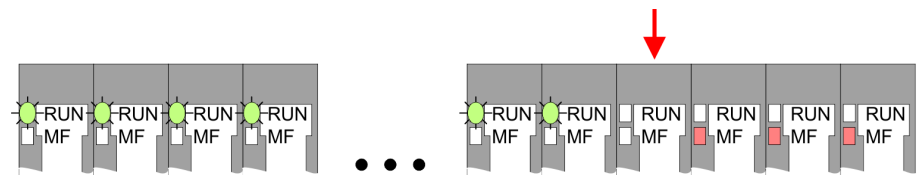

Behaviour: After PowerON all of the RUN LEDs up to the defective module are flashing. With all following modules the MF LED is on and the RUN LED is off.

Reason: The module on the right of the flashing modules is defective.

Remedy: Replace the defective module.

2.8 Installation guidelines

General

The installation guidelines contain information about the interference free deployment of a PLC system. There is the description of the ways, interference may occur in your PLC, how you can make sure the electromagnetic compatibility (EMC), and how you manage the isolation.

- What does EMC mean?** Electromagnetic compatibility (EMC) means the ability of an electrical device, to function error free in an electromagnetic environment without being interfered respectively without interfering the environment.
- The components of VIPA are developed for the deployment in industrial environments and meets high demands on the EMC. Nevertheless you should project an EMC planning before installing the components and take conceivable interference causes into account.
- Possible interference causes** Electromagnetic interferences may interfere your control via different ways:
- Electromagnetic fields (RF coupling)
 - Magnetic fields with power frequency
 - Bus system
 - Power supply
 - Protected earth conductor
- Depending on the spreading medium (lead bound or lead free) and the distance to the interference cause, interferences to your control occur by means of different coupling mechanisms.
- There are:
- galvanic coupling
 - capacitive coupling
 - inductive coupling
 - radiant coupling
- Basic rules for EMC** In the most times it is enough to take care of some elementary rules to guarantee the EMC. Please regard the following basic rules when installing your PLC.
- Take care of a correct area-wide grounding of the inactive metal parts when installing your components.
 - Install a central connection between the ground and the protected earth conductor system.
 - Connect all inactive metal extensive and impedance-low.
 - Please try not to use aluminium parts. Aluminium is easily oxidizing and is therefore less suitable for grounding.
 - When cabling, take care of the correct line routing.
 - Organize your cabling in line groups (high voltage, current supply, signal and data lines).
 - Always lay your high voltage lines and signal respectively data lines in separate channels or bundles.
 - Route the signal and data lines as near as possible beside ground areas (e.g. suspension bars, metal rails, tin cabinet).
 - Proof the correct fixing of the lead isolation.
 - Data lines must be laid isolated.
 - Analog lines must be laid isolated. When transmitting signals with small amplitudes the one sided laying of the isolation may be favourable.
 - Lay the line isolation extensively on an isolation/protected earth conductor rail directly after the cabinet entry and fix the isolation with cable clamps.
 - Make sure that the isolation/protected earth conductor rail is connected impedance-low with the cabinet.
 - Use metallic or metallised plug cases for isolated data lines.

- In special use cases you should appoint special EMC actions.
 - Consider to wire all inductivities with erase links.
 - Please consider luminescent lamps can influence signal lines.
- Create a homogeneous reference potential and ground all electrical operating supplies when possible.
 - Please take care for the targeted employment of the grounding actions. The grounding of the PLC serves for protection and functionality activity.
 - Connect installation parts and cabinets with your PLC in star topology with the isolation/protected earth conductor system. So you avoid ground loops.
 - If there are potential differences between installation parts and cabinets, lay sufficiently dimensioned potential compensation lines.

Isolation of conductors

Electrical, magnetically and electromagnetic interference fields are weakened by means of an isolation, one talks of absorption. Via the isolation rail, that is connected conductive with the rack, interference currents are shunt via cable isolation to the ground. Here you have to make sure, that the connection to the protected earth conductor is impedance-low, because otherwise the interference currents may appear as interference cause.

When isolating cables you have to regard the following:

- If possible, use only cables with isolation tangle.
- The hiding power of the isolation should be higher than 80%.
- Normally you should always lay the isolation of cables on both sides. Only by means of the both-sided connection of the isolation you achieve high quality interference suppression in the higher frequency area. Only as exception you may also lay the isolation one-sided. Then you only achieve the absorption of the lower frequencies. A one-sided isolation connection may be convenient, if:
 - the conduction of a potential compensating line is not possible.
 - analog signals (some mV respectively μA) are transferred.
 - foil isolations (static isolations) are used.
- With data lines always use metallic or metallised plugs for serial couplings. Fix the isolation of the data line at the plug rack. Do not lay the isolation on the PIN 1 of the plug bar!
- At stationary operation it is convenient to strip the insulated cable interruption free and lay it on the isolation/protected earth conductor line.
- To fix the isolation tangles use cable clamps out of metal. The clamps must clasp the isolation extensively and have well contact.
- Lay the isolation on an isolation rail directly after the entry of the cable in the cabinet. Lead the isolation further on to your PLC and don't lay it on there again!



CAUTION!

Please regard at installation!

At potential differences between the grounding points, there may be a compensation current via the isolation connected at both sides.

Remedy: Potential compensation line

General data

2.9 General data

Conformity and approval		
Conformity		
CE	2006/95/EG	Low-voltage directive
	2004/108/EG	EMC directive
Approval		
UL	UL 508	Approval for USA and Canada
others		
RoHS	2011/65/EU	Product is lead-free; Restriction of the use of certain hazardous substances in electrical and electronic equipment

Protection of persons and device protection		
Type of protection	-	IP20
Electrical isolation		
to the field bus	-	electrically isolated
to the process level	-	electrically isolated
Insulation resistance		-
Insulation voltage to reference earth		
Inputs / outputs	-	AC / DC 50V, test voltage AC 500V
Protective measures	-	against short circuit

Environmental conditions to EN 61131-2		
Climatic		
Storage / transport	EN 60068-2-14	-25...+70°C
Operation		
Horizontal installation	EN 61131-2	0...+60°C
Vertical installation	EN 61131-2	0...+60°C
Air humidity	EN 60068-2-30	RH1 (without condensation, rel. humidity 10... 95%)
Pollution	EN 61131-2	Degree of pollution 2
Mechanical		
Oscillation	EN 60068-2-6	1g, 9Hz ... 150Hz
Shock	EN 60068-2-27	15g, 11ms

Mounting conditions

Mounting place	-	In the control cabinet
Mounting position	-	Horizontal and vertical

EMC	Standard	Comment	
Emitted interference	EN 61000-6-4	Class A (Industrial area)	
Noise immunity zone B	EN 61000-6-2	Industrial area	
		EN 61000-4-2	ESD 8kV at air discharge (degree of severity 3), 4kV at contact discharge (degree of severity 2)
		EN 61000-4-3	HF field immunity (casing) 80MHz ... 1000MHz, 10V/m, 80% AM (1kHz) 1.4GHz ... 2.0GHz, 3V/m, 80% AM (1kHz) 2GHz ... 2.7GHz, 1V/m, 80% AM (1kHz)
		EN 61000-4-6	HF conducted 150kHz ... 80MHz, 10V, 80% AM (1kHz)
		EN 61000-4-4	Burst, degree of severity 3
		EN 61000-4-5	Surge, installation class 3 *

*) Due to the high-energetic single pulses with Surge an appropriate external protective circuit with lightning protection elements like conductors for lightning and overvoltage is necessary.

3 Hardware description

3.1 Properties

Features

- Ethernet coupler with EtherNet/IP for max. 64 peripheral modules
- I/O access of up to 8 stations
- Online configuration via integrated Web server
- RJ45 jack 100BaseTX, 10BaseTX
- Automatic polarity and speed recognition (auto negotiation)
- Automatic recognition of parallel or crossed cable (auto crossover)
- Network LEDs for link/activity
- Status LEDs for Ready and Error

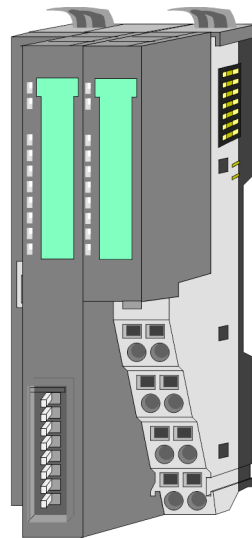

Order data

Type	Order number	Description
IM 053IP	053-1IP00	EtherNet/IP Ethernet coupler for System SLIO

3.2 Structure

053-1IP00

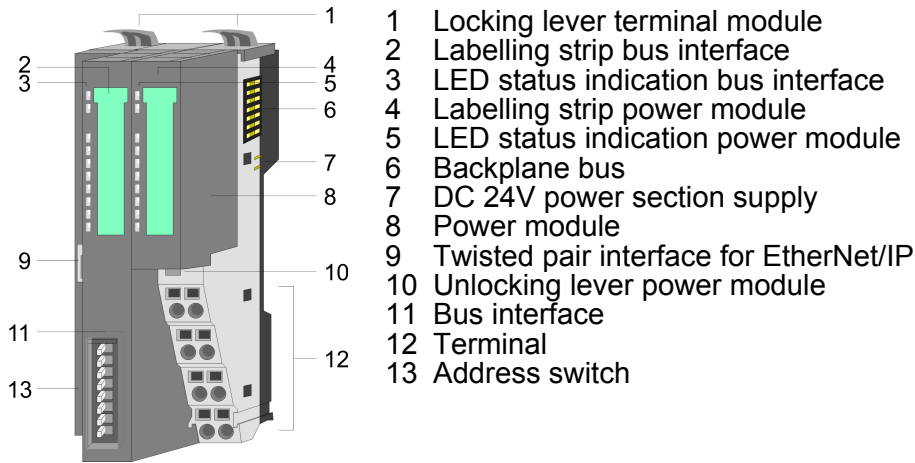

3.2.1 Interfaces

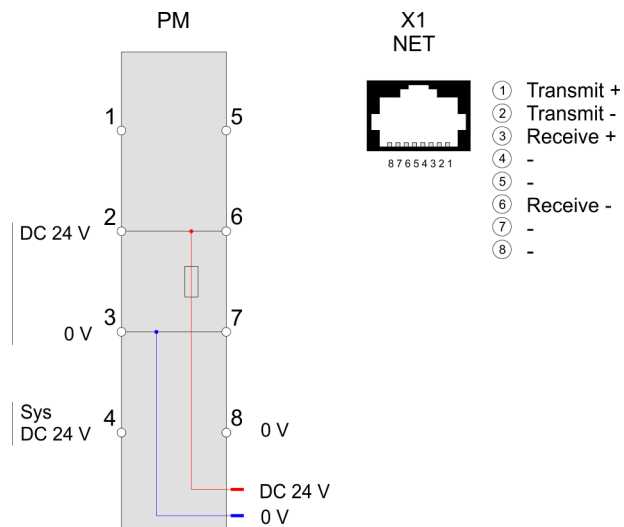

CAUTION!
 Bus interface and power module of the bus coupler may not be separated!
 Here you may only exchange the electronic module!

PM - Power module

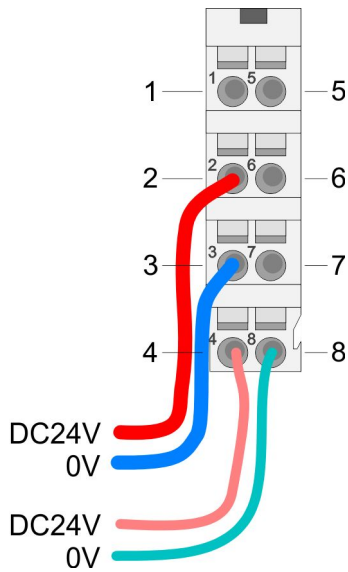

For wires with a core cross-section of 0.08mm² up to 1.5mm².

Pos.	Function	Type	Description
1	---	---	not connected
2	DC 24V	I	DC 24V for power section supply
3	0V	I	GND for power section supply
4	Sys DC 24V	I	DC 24V for electronic section supply
5	---	---	not connected
6	DC 24V	I	DC 24V for power section supply
7	0V	I	GND for power section supply
8	Sys 0V	I	GND for electronic section supply

I Input

EtherNet/IP interface X1

EtherNet/IP interface to connect to a EtherNet/IP network. EtherNet/IP can be operated in star topology via an already existing company network. To operate an EtherNet/IP network at least 1 scanner (master) is required.

3.2.2 Address switch

Setting the IP address via address switch

The address switch serves for the configuration of the IP address. On delivery the switch 2 (position 2) is switched to "1". Here the EtherNet/IP coupler has the following IP address data:

- Subnet mask: 255.255.255.0
- IP address: 192.168.1.1

The address switch has the following assignment:

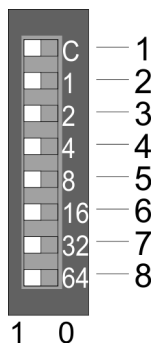

No.	Description
1	0 = DHCP off 1 = DHCP on
	4. Octet (x) of the IP address 192.168.1.x (max. value for x = 127)
2	2 ⁰ = 1 (default switched to "1")
3	2 ¹ = 2
4	2 ² = 4
5	2 ³ = 8
6	2 ⁴ = 16
7	2 ⁵ = 32
8	2 ⁶ = 64



- Changes of the IP address only take effect on PowerON or an automatic reset. Changes during operation are not recognized!
- The IP configuration via the address switch is dominant. Configurations, which are set by EtherNet/IP respectively web server, are valid/active when all the switches of the address switch are in position "0"!

3.2.3 LEDs

Bus-Interface

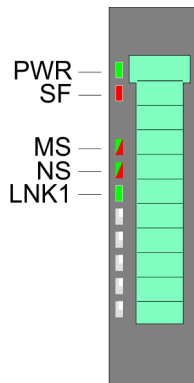

LED	Description		
PWR green	•	Bus interface is power supplied	
SF red	•	Error at Ethernet or at the System SLIO bus. Please perform a power cycle.	
	BB	Unrecoverable error - Please contact the VIPA hotline	
MS (module state) green/red	•	○	Module state: Operational
	BB	○	Module state: Standby (Idle) - BASP activated
	○	•	Unrecoverable error ¹ . Please perform a power cycle.
	○	BB	Recoverable error (e.g. error in configuration)
	BB	BB	Module state: Selftest
NS (network state) green/red	•	○	EtherNet/IP communication: RUN
	BB	○	There is no connection to a Scanner
	○	BB	Recoverable Ethernet/IP error
	BB	BB	Module state: Selftest
LNK1 green	BB		Network activity
	○		No network activity

on: • | off: ○ | blinking (2Hz): BB | not relevant: X

1) Please contact VIPA.

LEDs power module

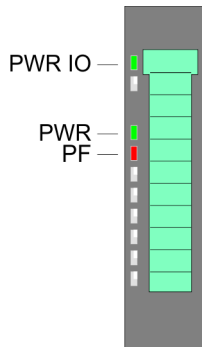

PWR IO	PWR	PF	Description
green ■	green ■	red ■	
●	X	○	Power section supply OK
●	●	○	Electronic section supply OK
X	X	●	Fuse electronic section supply defective
on: ● off: ○ not relevant: X			

3.3 Technical data

Order no.	053-1IP00
Type	IM 053IP
Module ID	-
Technical data power supply	
Power supply (rated value)	DC 24 V
Power supply (permitted range)	DC 20.4...28.8 V
Reverse polarity protection	✓
Current consumption (no-load operation)	95 mA
Current consumption (rated value)	0.95 A
Inrush current	3.9 A
I²t	0.14 A²s
Max. current drain at backplane bus	3 A
Max. current drain load supply	10 A
Power loss	3 W
Status information, alarms, diagnostics	
Status display	yes
Interrupts	yes, parameterizable
Process alarm	yes, parameterizable
Diagnostic interrupt	yes, parameterizable
Diagnostic functions	yes, parameterizable
Diagnostics information read-out	possible
Supply voltage display	green LED
Service Indicator	Bicolour green/red LED
Group error display	red SF LED
Channel error display	none
Hardware configuration	

Order no.	053-1IP00
Racks, max.	1
Modules per rack, max.	64
Number of digital modules, max.	64
Number of analog modules, max.	64
Communication	
Fieldbus	EtherNet/IP
Type of interface	Ethernet 10/100 MBit
Connector	RJ45
Topology	Star topology
Electrically isolated	✓
Number of participants, max.	-
Node addresses	IP V4 address
Transmission speed, min.	10 Mbit/s
Transmission speed, max.	100 Mbit/s
Address range inputs, max.	1 KB
Address range outputs, max.	1 KB
Number of TxPDOs, max.	-
Number of RxPDOs, max.	-
Housing	
Material	PPE / PPE GF10
Mounting	Profile rail 35 mm
Mechanical data	
Dimensions (WxHxD)	48.5 mm x 109 mm x 76.5 mm
Weight	155 g
Environmental conditions	
Operating temperature	0 °C to 60 °C
Storage temperature	-25 °C to 70 °C
Certifications	
UL certification	yes

4 Deployment

4.1 Basics EtherNet/IP

General

EtherNet/IP (Ethernet Industrial Protocol) is an open standard for industrial networks, which is real-time capable. EtherNet/IP is developed by ODVA (Open DeviceNet Vendor Association) and is standardized in IEC 61158. Especially in the U.S. market EtherNet/IP is a standard in communication.

EtherNet/IP

EtherNet/IP bases on TCP/IP. As user protocol CIP (Common Industrial Protocol) is used. CIP bases on a object model, which consists of classes, attributes, methods, states and instances. In contrast to the classical source-destination model, EtherNet/IP uses a modern producer/consumer model that requires data packets with identifier fields for the identification of the data. This approach caters for multiple priority levels, more efficient transfers of I/O data and multiple consumers for the data. A device that has data to send produces the data on the network together with an identifier. All devices requiring data listen for messages. When devices recognize a suitable identifier, they act and consume the respective data.

Via EtherNet/IP 2 types of messages are transported:

- Implicit communication - Messages for time-critical and control-oriented data, which are exchanged in a single or multiple cyclic connections. This connection is especially used for I/O data. For this the UDP protocol is used.
- Explicit communication - Here multipurpose point-to-point communication paths between two devices can be established. These are used in the configuration of the physical coupler and for diagnostics. This data are transferred with the TCP/IP protocol.

EtherNet/IP in the ISO/OSI layer model

The so called ISO/OSI layer model is generally accepted for the standardization of computer communication. The layer model is based upon seven layers with guidelines for the deployment of hard- and software.

Layer	Function	Protocols	
Layer 7	Application Layer (application)	CIP	
Layer 6	Presentation Layer (presentation)		
Layer 5	Session Layer (session)		
Layer 4	Transport Layer (transport)	TCP	UDP
Layer 3	Network Layer (network)	IP	
Layer 2	Data Link Layer (security)	Ethernet MAC	
Layer 1	Physical Layer (bit transfer)	Ethernet	

- Transfer medium** EtherNet/IP uses as transfer medium Ethernet cable.
 EtherNet/IP can be operated in star topology via an already existing company network. To operate an EtherNet/IP network at least 1 scanner (master) is required.
 The number of EtherNet/IP interface modules (slaves) is only limited by the number of available IP addresses and the performance of the scanner.
- Addressing** All stations of the network must be uniquely identified by means of an IP address. Every EtherNet/IP device has addressing facilities.
- EDS file** From VIPA there is an EDS (Electronic Data Sheet) files for the EtherNet/IP coupler available. There the scanner can find all the information to establish a communication connection to the EtherNet/IP coupler. This file may be found in the service area of www.vipa.com. Please install the EDS file in your configuration tool. Details on the installation of the EDS file are available from the manual supplied with your configuration tool.

4.2 Basics - IP address and subnet

- IP address structure** Exclusively supported is IPv4. At IPv4 the IP address is a 32bit address that must be unique within the network and consists of 4 numbers that are separated by a dot. Every IP address is a combination of a *Net-ID* and a *Host-ID* and has the following structure: **xxx.xxx.xxx.xxx**
 Range: 000.000.000.000 to 255.255.255.255
- Net-ID, Host-ID** The **Network-ID** identifies a network res. a network controller that administrates the network. The *Host-ID* marks the network connections of a participant (host) to this network.
- Subnet mask** The *Host-ID* can be further divided into a *Subnet-ID* and a new *Host-ID* by using a bit for bit AND assignment with the Subnet mask.
 The area of the original *Host-ID* that is overwritten by 1 of the Subnet mask becomes the *Subnet-ID*, the rest is the new *Host-ID*.

Subnet mask	binary all "1"		binary all "0"
IPv4 address	Net-ID	Host-ID	
Subnet mask and IPv4 address	Net-ID	Subnet-ID	new Host-ID

- Subnet** A TCP-based communication via point-to-point, hub or switch connection is only possible between stations with identical Network-ID and Subnet-ID! Different area must be connected with a router. The subnet mask allows you to sort the resources following your needs. This means e.g. that every department gets an own subnet and thus does not interfere another department.

Address classes

For IPv4 addresses there are five address formats (class A to class E) that are all of a length of 4byte = 32bit.

Class A	0	Network-ID (1+7bit)	Host-ID (24bit)
Class B	10	Network-ID (2+14bit)	Host-ID (16bit)
Class C	110	Network-ID (3+21bit)	Host-ID (8bit)
Class D	1110	Multicast group	
Class E	11110	Reserved	

The classes A, B and C are used for individual addresses, class D for multicast addresses and class E is reserved for special purposes. The address formats of the 3 classes A, B, C are only differing in the length of Network-ID and Host-ID.

Private IP networks

These addresses can be used as net-ID by several organizations without causing conflicts, for these IP addresses are neither assigned in the Internet nor are routed in the Internet. To build up private IP-Networks within the Internet, RFC1597/1918 reserves the following address areas:

Network class	from IP	to IP	Standard subnet mask
A	10.0.0.0	10.255.255.255	255.0.0.0
B	172.16.0.0	172.31.255.255	255.255.0.0
C	192.168.0.0	192.168.255.255	255.255.255.0

(The Host-ID is underlined.)

Reserved Host-IDs

Some Host-IDs are reserved for special purposes.

Host-ID = "0"	Identifier of this network, reserved!
Host-ID = maximum (binary complete "1")	Broadcast address of this network



Never choose an IP address with Host-ID=0 or Host-ID=maximum! (e.g. for class B with subnet mask = 255.255.0.0, the "172.16.0.0" is reserved and the "172.16.255.255" is occupied as local broadcast address for this network.)

4.3 Setting the IP address

Setting possibilities

- Setting the IP address via web server
- Setting the IP address via address switch
- Setting the IP address via standard object class



With the EtherNet/IP coupler you should always use a static IP address. Please consider when using a DHCP server that the IP address assignment (lease) is not changed in the DHCP server. Otherwise, after a restart of the EtherNet/IP coupler the coupler can not be found by the EtherNet/IP scanner.

Setting the IP address via web server

On delivery the EtherNet/IP coupler has the following IP address data:

Subnet mask:	255.255.255.0
IP address:	192.168.1.1

With this IP address the integrated web server can be accessed. There the IP address can be changed.

Setting the IP address via address switch

The address switch serves for the configuration of the IP address. On delivery the switch 2 (position 2) is switched to "1". Here the EtherNet/IP coupler has the following IP address data:

- Subnet mask: 255.255.255.0
- IP address: 192.168.1.1

The address switch has the following assignment:

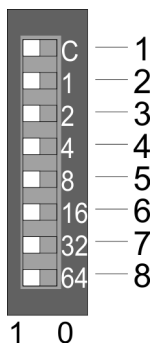

No.	Description
1	0 = DHCP off 1 = DHCP on
	4. Octet (x) of the IP address 192.168.1.x (max. value for x = 127)
2	$2^0 = 1$ (default switched to "1")
3	$2^1 = 2$
4	$2^2 = 4$
5	$2^3 = 8$
6	$2^4 = 16$
7	$2^5 = 32$
8	$2^6 = 64$



- Changes of the IP address only take effect on PowerON or an automatic reset. Changes during operation are not recognized!
- The IP configuration via the address switch is dominant. Configurations, which are set by EtherNet/IP respectively web server, are valid/active when all the switches of the address switch are in position "0"!

Setting the IP address via standard object class

The EtherNet/IP coupler supports the setting of the IP address by means of the standard object class TCP/IP (0xF5).
 ↪ further information on page 58



The setting of the IP address with the class 0xF5 is not possible if the IP address was configured via the address switches. First you have to disable DHCP, if you want to assign a static IP address via EtherNet/IP and DHCP was enabled by means of EtherNet/IP or web server, before!

4.4 Operating modes

Overview

The EtherNet / IP coupler can take the following operating states: which are described below:

- *Selftest* mode
- *Idle* mode
- *Operational* mode
- *Error* mode

Run/Idle header functionality is supported. Here you have the possibility to establish and release a communication connection by means of the scanner software.

Selftest mode

After PowerON the EtherNet/IP coupler executes a selftest in the *Selftest* mode. With a successful test the EtherNet/IP coupler automatically switches to the *Idle* mode and shows this by the blinking green MS LED.

Idle mode

In the *Idle* mode the EtherNet/IP coupler is in standby. The coupler waits for scanner connections. In Idle mode BASP (**B**efehls**a**usgab**e**s**p**er**r**e i.e. command output lock) is activated, this means all the module outputs are switched off and the inputs are not read.

Operational mode

As soon as at least one scanner establishes a communication connection to the EtherNet/IP coupler, the coupler switches to *Operational* mode. In *Operational* mode BASP is de-activated. The coupler copies the output data received from the scanner to its outputs and transmits the input values to the scanners.

Error-Mode

As soon as an error occurs during startup or operation the EtherNet/IP coupler switches to *Error* mode and shows this via LEDs. Here BASP is activated.

Transitions

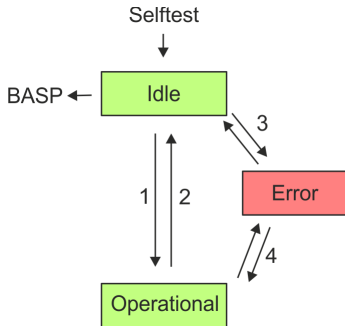

- 1 Transition from *Idle* to *Operational*: As soon as a communication connection to at least one scanner exists respectively at least one scanner is in "Run mode".
- 2 Transition *Operational* to *Idle*: As soon there is no communication connection to a scanner respectively every scanner is in "Idle mode". With the release of the last communication connection by the scanner, the EtherNet/IP coupler automatically switches to *Idle* mode.
- 3 With a configuration error e.g. in the FORDWARD_OPEN Config Assembly, the EtherNet/IP coupler switches directly from *Idle* mode to *Error* mode and shows this by the blinking red MS LED.
- 4 If e.g. the Ethernet cable is removed during operation the EtherNet/IP coupler switches directly from *Operational* mode to *Error* mode. BASP is activated. By plugging the Ethernet cable the EtherNet/IP coupler automatically return to *Operational* mode, if an communication connection to a scanner still exists. Otherwise it switches to *Idle* mode.

4.5 Web server

Access via IP address

The integrated web server can be accessed by means of this IP address data and these may be changed there. On delivery the EtherNet/IP coupler has the following IP address data:

Subnet mask:	255.255.255.0
IP address:	192.168.1.1



Please consider the System SLIO power and clamp modules do not have any module ID. These may not be recognized by the EtherNet/IP coupler and so are not listed and considered during slot allocation. Further within EtherNet/IP the slots are designated a 'EtherNet/IP-Slot'. The counting always begins with 0.

Structure of the web page

The web page is built dynamically and depends on the number of modules, which are connected to the EtherNet/IP coupler.

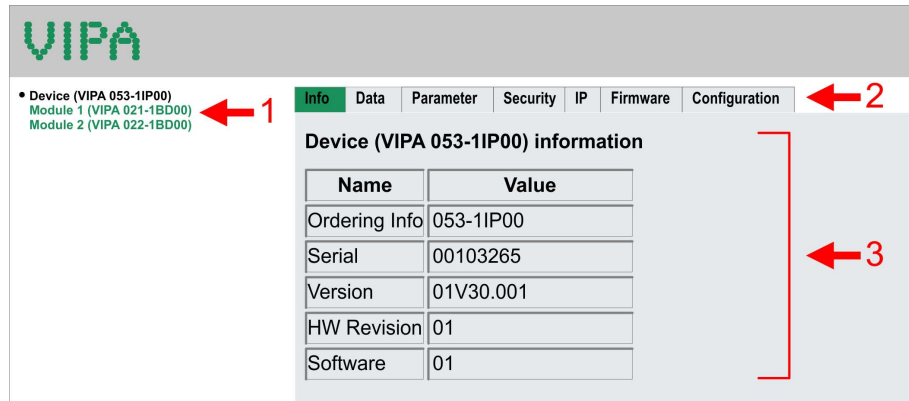

- [1] Module list: EtherNet/IP coupler and System SLIO modules in installed order
- [2] Functions for the module selected in the *module list*
- [3] Information respectively input area of the corresponding function



For fast diagnostics, missing or wrong configured modules are represented red coloured in the module list after refreshing the web page.

Web page of the selected EtherNet/IP coupler

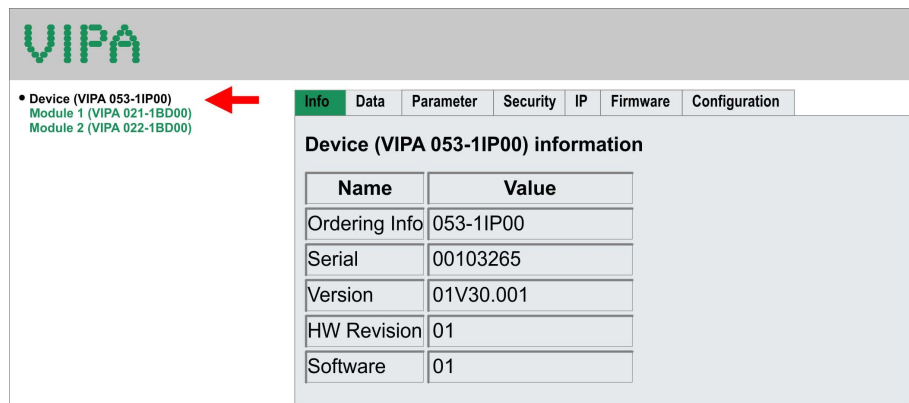

Info

Here order number, serial number and the version of firmware and hardware of the EtherNet/IP coupler are listed.

Data

Here the size of the process output and process input image is shown. The size information can be used when using dynamic assemblies. ↪ 'Instanz-ID 0x32 (50) to 0x3B (59) - Setpoint values (dynamic)' on page 64

Parameter

If there is an active connection between the EtherNet/IP coupler and the scanner, the current state of the parameter is displayed. If the EtherNet/IP coupler is not connected, you can see here the parameters stored internally as set points respectively web configuration.

Ignore Web Config - If this parameter is enabled, when editing the module parameter changes immediately with "Save" in the selection window adopted or enter values with the return.

If this parameter is disabled, during the start-up of the EtherNet/IP coupler, the configuration, which was stored in the Flash memory is shown.

Always send transmit address - If this parameter is enabled, in FORWARD_OPEN the EtherNet/IP coupler always responds with $\bar{T} \rightarrow O$ IP Address. You should enable this parameter with the deployment of a scanner, which was specified for an older standard.

Discard a single connection on timeout - With enabling this function the EtherNet/IP coupler automatically rejects a connection as soon as a timeout lasts longer than 10 seconds. This parameter can also be activated via FORWARD_OPEN. ↪ 'Discard On Timeout (0x0A)' on page 58

Security

All functions for the writing access to the EtherNet/IP coupler can be secured by a password.

IP

Here you can enter IP address data for the EtherNet/IP coupler. Only if the bus is in BASP, an input is possible, this means no scanner is connected or every connected scanner is in Idle mode. Otherwise the input fields are de-activated but the settings are shown. For valid IP address data please contact your system administrator. Directly after entering the IP address will be accepted; the web server can now only be reached via the new IP address.

Firmware

With this function you can bring in a firmware update. You can get the appropriate firmware file from VIPA. During the firmware update, SF and MS (red) are blinking alternately. When the update is finished all the red LEDs are switched ON. Then you have to perform a power cycle.

Configuration

In this dialog field you have the possibility to store the current module configuration or to import a module configuration. With [Delete] the parameterization of all the modules may be deleted in the EtherNet/IP coupler.

- Export Station Configuration - With [Save] a window is opened and shows the configuration as XML. Select File > Save as and save the current configuration as XML file.
- Import Station and Modules Configuration - Select with [Search...] the according XML file and load this with [Load]. While loading the parameters of the EtherNet/IP coupler and the modules are loaded.
- Import Modules Configuration - Select with [Search...] the according XML file and load this with [Load]. While loading only the parameters of the modules are loaded. The parameters of the EtherNet/IP coupler further exist.
- Save Configuration of all Modules - With [Save] the current configuration is retentive stored in the EtherNet/IP coupler. If the current module ID deviates from the just configured module ID after a connection establishment, the EtherNet/IP coupler does not go into RUN and shows the error on its web page.
- Delete Configuration of all Modules - With [Delete] the configuration in the EtherNet/IP coupler may be deleted.



Please consider that a retentive saved configuration is only loaded when a scanner has set up a connection. Otherwise, you see the default parameters after a reboot.

Only there is a configuration for a module, this may be used to check preset and current configuration. If the current configuration differs from the preset (e.g. module was removed) the system reports an error and does not go to RUN. If the current configuration is changed during operation by plugging respectively removing a module, the EtherNet/IP coupler switches to STOP. Then a power cycle is necessary.

Web page with selected module

The screenshot shows the VIPA web interface. On the left sidebar, there is a tree view with the following items:

- Device (VIPA 053-1IP00)
- Module 1 (VIPA 021-1BD00) - This item is selected, indicated by a red arrow pointing to it.
- Module 2 (VIPA 022-1BD00)

 The main content area has tabs for 'Info', 'Data', and 'Parameter'. The 'Info' tab is active, showing 'Module 1 (VIPA 021-1BD00) information'. Below this is a table with the following data:

Name	Value
Ordering Info	021-1BD00
Serial	00103265
Version	01V30.001
HW Revision	01

Info

Here product name, order number, serial number, firmware version and hardware state number of the according module are listed.

Data

At *Data* the states of the inputs respectively outputs are listed. In addition, you can directly control the outputs of the corresponding module.

Parameter

If available the parameter data of the corresponding module may be shown and changed if necessary. Here BASP must be activated the EtherNet/IP coupler. ↪ *'Idle mode'* on page 42

With [Save], the parameters are not retentive written to the module and are active. With a reboot of the coupler the parameters are deleted.

To store the parameters permanently you have to save the configuration with *'Configuration → Save current Device Parameters → Module Parameters into remanent memory'* afterwards. ↪ *'Configuration'* on page 46

4.6 Accessing the System SLIO

4.6.1 Overview

- The EtherNet/IP coupler can control maximally 64 system SLIO modules.
- A system SLIO module can contain 1 ... 60byte I/O data.
- For the transport of this data stream, the data must be divided into EtherNet/IP packages and encapsulated.
 - Each package starts with the interrupt flags (1byte). With a pending hardware interrupt respectively diagnostics interrupt the according flag is set.
 - Behind the interrupt flags there is the length ModLen located in the data stream followed by the I/O data of the modules in plugged sequence. Information concerning the allocation of the I/O area of a module may be found in the description of the corresponding System SLIO module.

From VIPA you may receive an EDS file (Electronic Data Sheet) for your EtherNet/IP coupler. The file may be found in the service area at www.vipa.com. Please install the EDS file in your configuration tool. Details on the installation of the EDS file are available in the manual supplied with your configuration tool.



Should there be unstable connections due to timeouts, so you can make the following settings after installing the EDS file:

- *Input T → O change to 'point2point'*
- *Output O → T change to 'point2point'*

Example Rockwell:

- *Assembly Instance 'Input' T → O: 20decimal, Size: 496byte*
- *Assembly Instance 'Output' O → T: 10decimal, Size: 496byte*
- *Assembly Instance 'Configuration': 30decimal, Size: 400byte*

In the following you will find the description of accessing I/O area, parameter data and diagnostics data of the System SLIO via EtherNet/IP. Here '*I stream*' is according to assembly class with Instance-ID 0x0A and '*O stream*' is according to assembly class with instance-ID 0x14. ↪ '*Instance ID 0x14 (20) to 0x1D (29) - Actual values (496byte)*' on page 64

You can start the communication with a *Class1 connection*. This should be a point-to-point connection in both directions. Here the frame size depends on the configured *assembly class*.

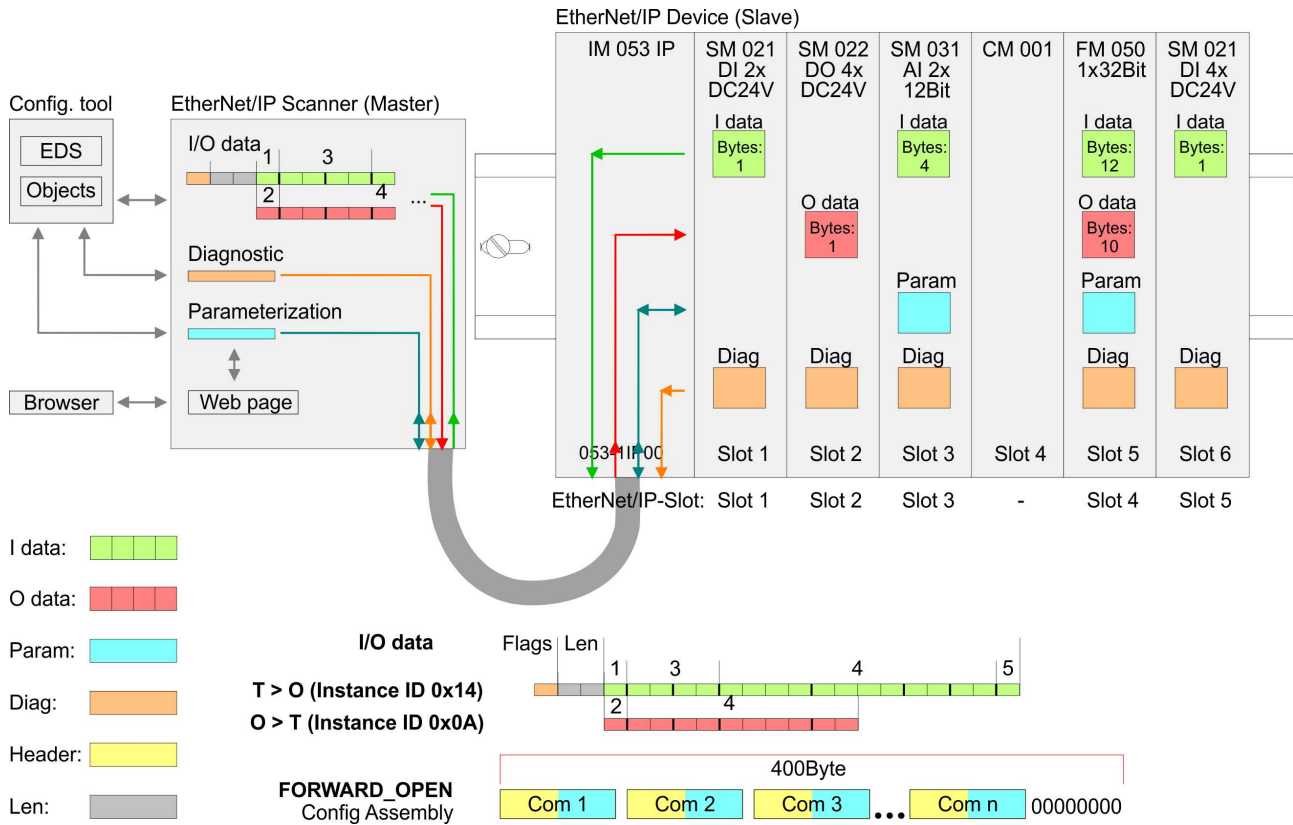

i Please consider the System SLIO power and clamp modules do not have any module ID. These may not be recognized by the EtherNet/IP coupler and so are not listed and considered during slot allocation.

Further within EtherNet/IP the slots are designated as EtherNet/IP-Slot. The counting always begins with 1.

4.6.2 Accessing I/O area

The EtherNet/IP coupler determines automatically the modules on the System SLIO bus and generates from this the number of input and output bytes. Information concerning the I/O allocation of a module may be found in the corresponding manual. The position (offset) of the input respectively output bytes within the input respectively output data results from the order of the modules (EtherNet/IP-Slot 1 ... 64). By means of the base address, which is to be preset in the EtherNet/IP scanner for the bus coupler and the offset you may access the input or output data of a module. During operation the EtherNet/IP coupler cyclically reads the input data of the peripheral modules and serves for the last state of these data for the EtherNet/IP scanner. Output data, which the EtherNet/IP coupler has received from the EtherNet/IP scanner, were directly transferred to the modules, as soon as they were received.

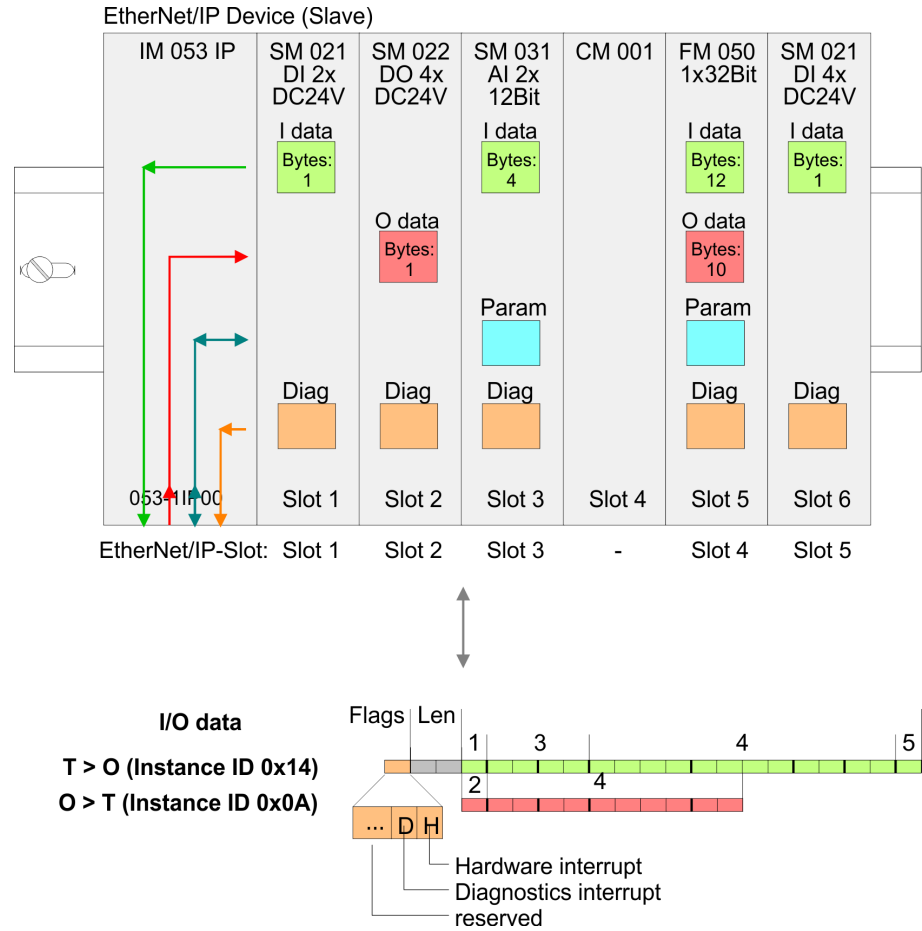

Structure of the Input data (Instance ID 0x14)

Byte	Structure	Field name	Data type	Field value
0	Header	Interrupt-Flags	USINT	Interrupt and diagnostics flags. An interrupt is pending when the corresponding bit is set. Bit 0: Hardware interrupt Bit 1: Diagnostics interrupt Bit 7 ... 2: reserved
1		ModLen	UINT	Length of the module data
3	Module packages	ModData	ARRAY of USINT	Module data (see manual System SLIO module)

4.6.3 Accessing the parameter data

For the parameterization of the System SLIO modules you have the following possibilities:

- Parameterization via web page
- Parameterization via FORWARD_OPEN

Parameterization via the web page

When power cycle the coupler, parameterizable modules can be operated with their default parameters. If you want to change parameters the EtherNet/IP coupler respectively the corresponding modules may be parameterized via the integrated Web page. Here by means of the corresponding *EtherNet/IP-Slot* parameter may be viewed and changed.

Parameterization via 'FORWARD_OPEN'

With this method the EtherNet/IP scanner passes in the FORWARD_OPEN call a *config assembly* to the EtherNet/IP coupler. The *config assembly* is a collection of commands and has a fixed size of 400byte.

Here the corresponding System SLIO module can be parameterized with the command *SetModParam* by specifying the *EtherNet/IP-Slot* at '*Pos*' and the module parameters at '*Param*'. ↪ [Chapter 4.7 'Deployment of FORWARD_OPEN' on page 53.](#)

The description of the parameters can be found in the manual of the according System SLIO module.

Error codes

Code	Description
0x0000	Command has been executed without error.
0x0001	Configuration in FORWARD_OPEN could not be read.
0x0002	Unknown command in <i>config assembly</i> .
0x0003	Length in <i>config assembly</i> is not correct.
0x0004	Data missing for the command.
0x0005	<i>SetIOStart</i> twice in <i>config assembly</i> .
0x0006	<i>SetModCnt</i> twice in <i>config assembly</i> .
0x0007	<i>SetModCnt</i> overflows max available number of modules.
0x0008	<i>SetModType</i> overflows max available number of modules.
0x0009	<i>SetModType</i> for same module twice in <i>config assembly</i> .
0x000A	<i>NoFwdOpenCfg</i> twice in <i>config assembly</i> .
0x000B	<i>IgnoreWebCfg</i> twice in <i>config assembly</i> .
0x000C	<i>UseExistingCfg</i> twice in <i>config assembly</i> .
0x000D	<i>SetModCnt</i> underflows min. available modules.
0x000E	<i>SetModCnt</i> doesn't match EtherNet/IP coupler module count.
0x000F	System SLIO Bus could not return the module ID.
0x0010	<i>SetModType</i> found wrong-plugged module.
0x0011	<i>DeleteWebCfg</i> twice in <i>config assembly</i> .
0x0012	This function is not supported.
0x0013	<i>SlioModGetParameterLength</i> is wrong in <i>SetModParam</i> .
0x0014	The length of <i>SetModParam</i> differs to the expected length of the module.
0x0015	<i>SlioModSetParameters</i> faulty in <i>SetModParam</i> .
0x0016	<i>SetModParam</i> is greater than the max. possible number of modules.
0x0017	<i>SetIOStart</i> could not find assembly information.
0x0018	<i>SetIOStart</i> : The assembly has the wrong type.
0x0019	<i>SetIOStart</i> is behind the available data length of the module.
0x001A	Initialization: <i>ClientStart</i> was faulty.
0x001B	Initialization: Assembly with input data could not be added.
0x001C	Initialization: Assembly with output data could not be added.
0x001D	Initialization: <i>Config assembly</i> could not be added.
0x001E	Initialization: Identity object could not be initialized.
0x001F	Initialization: Identity object could not be set.
0x0022	<i>SetModTypeRange</i> : There were more modules configured as exist.
0x0023	<i>SetModTypeRange</i> : A wrong plugged module was found.
0x0024	Initialization: Initialization could not be executed.

4.6.4 Accessing diagnostics data

As soon as a module reports an interrupt via the backplane bus, this is automatically recognized by the EtherNet/IP coupler.

By setting the according interrupt bit in the I/O data stream the EtherNet/IP coupler reports this to the EtherNet/IP scanner. In the EtherNet/IP scanner you can adequately respond to the alarm.

Parts of the diagnostics data can be accessed by means of EtherNet/IP objects. ↪ Chapter 4.8 'EtherNet/IP - Objects' on page 58

4.7 Deployment of FORWARD_OPEN

Structure

The FORWARD_OPEN *config assembly* can be combined by various commands and has the following structure:

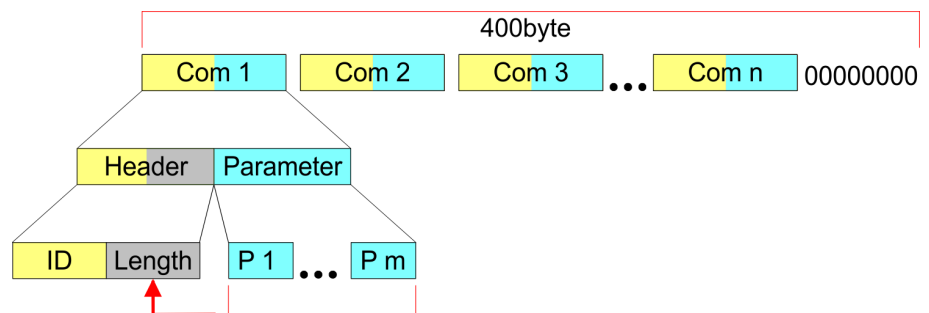

- The length of the *config assembly* is always 400byte. Unused areas are to be zeroed.
- The *config assembly* is always to be finished with END_OF_CFG!
- The data within the *config assembly* always consist of a collection of *commands*.
- A command always consists of *command header* and *command parameter*.
- A command header always consists of a *command ID* and a *length* (number bytes of command parameters).
- In *command parameter* the command specific data are specified.

Example

Here an example of FWD_OPEN:

CMD 1: Ignore Webconfig: 01 00

CMD 2: Number of modules (5): 03 01 05

CMD 3: SetModuleType yy to Pos 3: 04 05 y4 y3 y2 y1 03

The specification for the type has to take place here in the little-endian format (least-significant byte first)

CMD 4: End of Config: 00

CMD 1...4: 01 00 | 03 01 05 | 04 05 y4 y3 y2 y1 03 | 00

→ FWD_OPEN command: 010003010405y4y3y2y10300

4.7.1 Command IDs

Below there is a list of all the commands, which can be used in a FORWARD_OPEN *config assembly*. Please configure that the *config assembly* can be limited any time by means of the command *EndOfCfg*. After you insert the command *EndOfCfg* all subsequent commands are ignored.

Elementary data types

Name	Description	Area	
		Minimum	Maximum
BOOL	Boolean	0: False	1: True
SINT	Short integer	-128	127
INT	Integer	-32768	32767
DINT	Double integer	-2 ³¹	2 ³¹ -1
LINT	Long integer	-2 ⁶³	2 ⁶³ -1
USINT	Unsigned short integer	0	255
UINT	Unsigned integer	0	65535
UDINT	Unsigned double integer	0	2 ³² -1
ULINT	Unsigned long integer	0	2 ⁶⁴ -1
STRING	Character String (1byte per character)	-	-
SHORT_STRING	Character String (1byte per character + 1byte length)	-	-
BYTE	Bit string 8bits	-	-
WORD	Bit string 16bits	-	-
DWORD	Bit string 32bits	-	-
LWORD	Bit string 64bits	-	-

EndOfCfg (0x00)

The command *EndOfCfg* (0x00) specifies that the configuration finishes at the inserted position. The subsequent commands after this command are ignored.

Structure	Field name	Data type	Value	Designation
Command header	ID	USINT	0x00	EndOfCfg
	Length	USINT	0x00	No parameters



The config assembly is always to be finished with END_OF_CFG!

IgnoreWebCfg (0x01)

The command *IgnoreWebCfg* (0x01) specifies that the EtherNet/IP coupler has to ignore an existing web configuration and may only be configured by a FORWARD_OPEN *config assembly*.

Structure	Field name	Data type	Value	Designation
Command header	ID	USINT	0x01	IgnoreWebCfg
	Length	USINT	0x00	No parameters

DeleteWebCfg (0x02)

The command *DeleteWebCfg* (0x02) specifies that the EtherNet/IP coupler has to delete an existing web configuration and may only be configured by a FORWARD_OPEN *config assembly*.

Structure	Field name	Data type	Value	Designation
Command header	ID	USINT	0x02	DeleteWebCfg
	Length	USINT	0x00	No parameters

UseExistingCfg (0x08)

The command *UseExistingCfg* (0x08) commits the EtherNet/IP coupler to use an existing I/O connection for configuration. The command *UseExistingCfg* is mandatory when a second connection to the coupler is to be established. With this command all the configuration parameters in the *config assembly* are ignored, except *SetIOStart* (0x07).

Structure	Field name	Data type	Value	Designation
Command header	ID	USINT	0x08	UseExistingCfg
	Length	USINT	0x00	No parameters

SetIOStart (0x07)

The command *SetIOStart* (0x07) defines the I/O area of the System SLIO bus image, which is to be cyclically transferred in the selected assembly *AsmId*. This is only possible with static Assemblies (0x14 - 0x1D). Since an I/O connection may only transfer max. 496byte I/O data (excluding interrupt header and length), with *SetIOStart* a second connection may be opened to transfer the specified start area. This command can be used e.g. with *UseExistingCfg*.

Structure	Field name	Data type	Value	Designation
Command header	ID	USINT	0x07	SetIOStart
	Length	USINT	0x03	Length of the command data
Command specific data	AsmId	USINT		Number of the assembly
	Start	UINT		Start of the I/O data area of the according assembly

SetModCnt (0x03)

The command *SetModCnt* (0x03) specifies the number of modules by the parameter *ModCnt*.

Structure	Field name	Data type	Value	Designation
Command header	ID	USINT	0x03	SetModCnt
	Length	USINT	0x01	Length of the command data
Command specific data	ModCnt	USINT	1 ... 64	Number of modules

SetModType (0x04)

The command *SetModType* (0x04) specifies the module ID *ModID* of the module at position *Pos*.

Structure	Field name	Data type	Value	Designation
Command header	ID	USINT	0x04	SetModType
	Length	USINT	0x05	Length of the command data
Command specific data	ModID	UDINT		Module ID (see technical data System SLIO)
	POS	USINT	1 ... 64	Module position

SetModTypeRange (0x05)

The command *SetModTypeRange* (0x05) specifies the module ID *ModID* of the modules starting with position *PosStart* to position *PosEnd*.

Structure	Field name	Data type	Value	Designation
Command header	ID	USINT	0x05	SetModTypeRange
	Length	USINT	0x06	Length of the command data
Command specific data	ModID	UDINT		Module ID (see technical data System SLIO)
	PosStart	USINT	1 ... 63	Start position
	PosEnd	USINT	2 ... 64	End position

SetModParam (0x06)

The command *SetModParam* (0x06) specifies the module parameter Para of the module at position Pos. A description of the parameters may be found in the manual of the according System SLIO module.



To get the current parameters as basis record set for parameterization, you can use a 'class3 connection'!

Structure	Field name	Data type	Value	Designation
Command header	ID	USINT	0x06	SetModParam
	Length	USINT	0x01 + n	Length of the command data
Command specific data	Pos	USINT	1 ... 64	Module position
	Param	ARRAY of USINT	n = number	Module parameter

Discard On Timeout (0x0A)

With the command *DiscardOnTimeout* (0x0A) the EtherNet/IP coupler rejects a connection as soon as a timeout lasts longer than 10 seconds.

Structure	Field name	Data type	Value	Designation
Command header	ID	USINT	0x0A	DiscardOnTimeout
	Length	USINT	0x00	No parameters

4.8 EtherNet/IP - Objects

Classes, Objects, Instances and Attributes

'Objects' are specified by their properties. The properties are called attributes. Similar objects are summarized in 'object classes'. An 'object', which was built during run-time of a class is an 'instance'.

The EtherNet/IP coupler supports the following objects:

- Standardized EtherNet/IP objects
- VIPA specified EtherNet/IP objects

4.8.1 Standardized EtherNet/IP Objects

The following standardized object classes are supported by the EtherNet/IP coupler:

Object classes	Description
Message Router (0x02)	Distributed explicit requests to the associated handler
Connection Manager (0x06)	Responsible for different areas of the connection
Port (0x55)	Abstraction of a physical network connection
Identity (0x01)	Provides identification and general information about the device.
Ethernet Link (0xF6)	Shows information about the network interface (Error counter, ...)
TCP/IP (0xF5)	Configuration of the TCP/IP interface (e.g. IP address, Netmask, Gateway)
Assembly (0x04)	Combines more attributes in one I/O connection
Custom Objects	Self-defined objects



More information about the standardized EtherNet/IP object classes may be found in the according EtherNet/IP respectively CIP standard of the ODVA (Open DeviceNet Vendor Association).

4.8.2 VIPA specific EtherNet/IP objects

The following VIPA specific object classes are supported by the EtherNet/IP coupler:

Object class	Description
I/O data (0x64)	Access to the I/O data of the System SLIO
Diagnostics and interrupt (0x65)	Access to the diagnostics and interrupt specific settings
Module (0x66)	Access to the configuration, diagnostics and status data of the modules
Coupler (0x67)	Access to the configuration and status data of the EtherNet/IP coupler
Assembly (0x04)	Access to the I/O and diagnostics data

I/O data class (code: 0x64)

With this class the I/O data, which were configured via FORWARD_OPEN before, may be accessed.

The instances represent the INPUT respectively OUTPUT assemblies. Enter here 0 for the *instance*.

Is the ID assigned to the first INPUT assembly e.g. number 20, so the instance 20 is directly assigned with this assembly.

The attribute IDs of the object class can be found in the following table:

Attribute ID	Access	Name	Data type	Description
0x64	Set	I/O Set	ARRAY of BYTE	Setpoint (outputs)
0x65	Get	I/O Get	ARRAY of BYTE	Actual value (inputs)

Diagnostics and interrupt class (code: 0x65)

With this class the diagnostics and interrupt specific settings can be accessed. If this data have to be manually reset, this happens by the module class.

With *Instance* you can define which System SLIO slot is to be accessed (0: EtherNet/IP coupler, 1: 1. System SLIO module, 2: System SLIO module, etc. ...)



Please consider the System SLIO power and clamp modules do not have any module ID. These may not be recognized by the EtherNet/IP coupler and so are not considered during slot allocation.

The attribute IDs of the object class can be found in the following table:

Attribute ID	Access	Name	Data type	Description
0x64	Get	Status	USINT	Access to the status byte of the I/O data. An interrupt is pending, if the according bit is set: Bit 0: Process interrupt Bit 1: Diagnostics interrupt Bit 7 ... 2: reserved
0x65	Set	Process Reset Config	BYTE	Here is specified when a hardware interrupt is to be reset: 0: Active reset by attribute 0x6D of the module class 1: Automatically after request (standard)
0x66	Set	Diagnostic Reset Config	BYTE	Here is specified when a diagnostics interrupt is to be reset: 0: Active reset by attribute 0x6E of the module class 1: Automatically after request (standard)
0x67	Set	Reset Process and Diagnostic Data	no data	Deletes each available process and diagnostic data (API SlioModClearAllErrors)

Attribute ID	Access	Name	Data type	Description
0x68	Get	Next Process Alarm	see table below	Reads the next available hardware interrupt. Contains the raw data of the interrupt type IO_EVENT_PROCESS_ALARM
0x69	Get	Next Diagnostic Data	see table below	Reads the next available diagnostics interrupt. Contains the raw data of the interrupt type IO_EVENT_DIAGNOSTIC_ALARM

Structure of the interrupt and diagnostic data

Field name	Data type	Field value
Pos	USINT	Module position (1 ... 64)
Length	UINT	Length of the interrupt and diagnostics data
Data	ARRAY of BYTE	Interrupt and diagnostics data in raw format

Module class (code: 0x66)

This class offers access to the configuration, diagnostics and status data of the System SLIO modules. Besides the module descriptive attributes there are the attributes 0x6B and 0x6C to read the module-specific hardware interrupt and diagnostics data. If the manual reset of hardware and diagnostics interrupts is set by the diagnostics and interrupt class, a interrupt can be acknowledged by means of the attributes Attribute 0x6D respectively 0x6E. With *Instance* the System SLIO slot is defined, which is to be accessed.



Please consider the System SLIO power and clamp modules do not have any module ID. These may not be recognized by the EtherNet/IP coupler and so are not considered during slot allocation.

The attribute IDs of the object class can be found in the following table:

Attribute ID	Access	Name	Data type	Description
0x64	Get/Set	Config	ARRAY of BYTE	Module configuration
0x65	Set	ClearCounter	no data	Clear module counter
0x66	Get	GetMDL	WORD	Module MDL read counter
0x67	Get	GetNDL	WORD	Module NDL read counter
0x68	Get	VerFPGA	WORD	FPGA version
0x69	Get	VerFW	ARRAY of BYTE	Firmware version
0x6A	Get	Serial	ARRAY of BYTE	Serial number

Attribute ID	Access	Name	Data type	Description
0x6B	Get	Process Alarm	see table below	Contains the raw data of the interrupt type IIO_EVENT_PROCESS_ALARM
0x6C	Get	Diagnostic Data	see table below	Contains the raw data of the interrupt type IO_EVENT_DIAGNOSTIC_ALARM
0x6D	Set	Process Reset	no data	Reset the hardware interrupt
0x6E	Set	Diagnostic Reset	no data	Reset the diagnostics interrupt

Structure of the interrupt and diagnostics data

Field name	Data type	Field value
Pos	USINT	Module position (1 ... 64)
Length	UINT	Length of the interrupt and diagnostics data
Data	ARRAY of BYTE	Interrupt and diagnostics data in raw format

Coupler class (code: 0x67)

This class offers access to the parameter and status data of the Ethernet/IP coupler. The *Instance* is always 0. The attribute IDs of the object class can be found in the following table:

Attribute ID	Access	Name	Data type	Description
0x64	Get/Set	Config	ARRAY of BYTE	Coupler configuration
0x65	Set	ClearCounter	no data	Clear master counter
0x66	Get	GetMC	BYTE	Read master counter
0x67	Get	GetELE	WORD	Expected length error
0x68	Get	GetTOE	WORD	Time-out error
0x69	Get	GetSBE	WORD	Stop-bit error
0x6A	Get	GetFCSE	WORD	FCS error
0x6B	Get	GetTLE	WORD	Telegram length error
0x6C	Get	GetTTE	WORD	Telegram type error
0x6D	Get	GetARE	WORD	Alarm retry error
0x6E	Get	GetBITE	WORD	Bus idle time error
0x6F	Get	GetWNA	WORD	Wrong node address
0x70	Get	GetTV	WORD	Telegram valid
0x71	Get	GetML	WORD	Master load
0x72	Get	VerSLIO	BYTE	SLIO version

Attribute ID	Access	Name	Data type	Description
0x73	Get	VerFPGA	WORD	FPGA version
0x74	Get	VerBus	WORD	SLIO bus version
0x75	Get	VerFwPkt	DWORD	Firmware packet version
0x76	Get	VerMxFile	STRING	Name and version of the Mx file
0x77	Get	GetModulIDs	ARRAY of BYTE	List of plugged system SLIO modules
0x78	Get/Set	SaveCfg	WORD	Configuration: stored (Get) / store (Set) <ul style="list-style-type: none"> ■ Bit 1: Web configuration ■ Bit 2: Network configuration ■ Bit 3: Module configuration

Coupler configuration

Byte	Content
Byte 0	Bit 0: IgnoreWebConfig Bit 1: Auto Reset ProcessAlarmflag Bit 2: Auto Reset DiagnosticAlarmflag Bit 3: Always Send Transmit Addr Bit 7 ... 4: reserved
Byte 1	Number of plugged modules
Byte 2 - n	4 byte per module, which corresponds to the module ID



Should there be unstable connections due to timeouts, so you can make the following settings after installing the EDS file:

- *Input T → O change to 'point2point'*
- *Output O → T change to 'point2point'*

Example Rockwell:

- *Assembly Instance 'Input' T → O: 20decimal, Size: 496byte*
- *Assembly Instance 'Output' O → T: 10decimal, Size: 496byte*
- *Assembly Instance 'Configuration': 30decimal, Size: 400byte*

4.8.2.1 Assembly instances

Assembly-class (code: 0x04) In the following the VIPA specific instances are listed for R/W access and for read access to the diagnostics data.

Instances

Instance ID 0x0A (10) to 0x13 (19) - Setpoint values (496byte)

Byte	Type	Content
0	ARRAY of BYTE	Setpoint values (outputs) - output assembly (O → T)

Since an connection via output assembly can only transfer a maximum of 496byte I/O data (less interrupt header and length), with *SetIOStart* a second connection can be opened over which the defined start area is transferred. ↪ *'SetIOStart (0x07)' on page 56*

Instance ID 0x14 (20) to 0x1D (29) - Actual values (496byte)

Byte	Type	Content
0	USINT	Header
1	UINT	ModLen
3	ARRAY of BYTE	Actual values (inputs) - input assembly (T → O)

Since an connection via input assembly can only transfer a maximum of 496byte I/O data (less interrupt header and length), with *SetIOStart* a second connection can be opened over which the defined start area is transferred. ↪ *'SetIOStart (0x07)' on page 56*

Instance-ID 0x1E (30) - Config (400byte)

Byte	Type	Content
0	ARRAY of BYTE	ForwardOpen ↪ <i>Chapter 4.7 'Deployment of FORWARD_OPEN' on page 53</i>

Instanz-ID 0x32 (50) to 0x3B (59) - Setpoint values (dynamic)

Byte	Type	Content
0	ARRAY of BYTE	Setpoint values (dyoutputs) - Output Assembly

The value of the size is dynamic and corresponds to the size of the process image of the outputs in byte. ↪ *'Data' on page 44*

Instanz-ID 0x3C (60) to 0x45 (69) - Actual values (dynamic)

Byte	Type	Content
0	USINT	Header
1	UINT	ModLen
3	ARRAY of BYTE	Actual values (inputs) - input assembly (T → O)



For small systems with short cycle times, you should use instances with dynamic values

Instance ID 0x79 (121) - Diagnostics (4byte)

Byte	Type	Content
0	WORD	System diagnostics: Bit 0: Scanner for time x lost Bit 1: Sporadic interrupt Bit 2: Long response time Bit 3: Module permutation Bit 15 ... 4: reserved
2	BYTE	Module diagnostics: Bit 0: Hardware interrupt (group interrupt) Bit 1: Diagnostics interrupt (group interrupt) Bit 7 ... 2: reserved
3	BYTE	reserved

Instance ID 0x7A (122) - Extended diagnostics (20byte)

Byte	Type	Content
0	WORD	System diagnostics: Bit 0: Scanner for time x lost Bit 1: Sporadic interrupt Bit 2: Long response time Bit 3: Module permutation Bit 15 ... 4: reserved
2	WORD	reserved
4	LWORD	Hardware interrupt: Bit 0: Module 1 Bit 1: Module 2 Bit 63 ... 2: reserved
12	LWORD	Diagnostics interrupt: Bit 0: Module 1 Bit 1: Module 2 Bit 63 ... 2: reserved

Instance ID 0x7B (123) - Diagnostics & actual values (500byte)

Byte	Type	Content
0	DWORD	Instance ID 121 (diagnostics)
4	ARRAY of BYTE	Instance ID 120 (actual values) (input assembly 1)

Instance ID 0x7C (124) - Extended Diagnostics & actual values (516byte)

Byte	Type	Content
0	DWORD LWORD LWORD	Instance ID 122 (extended diagnostics)
20	ARRAY of BYTE	Instance ID 120 (actual values) (input assembly 1)

4.9 Examples

4.9.1 Configuration at a Yaskawa MWIEC scanner

Proceeding

1. ▶ Open MotionWorks from Yaskawa with your project.

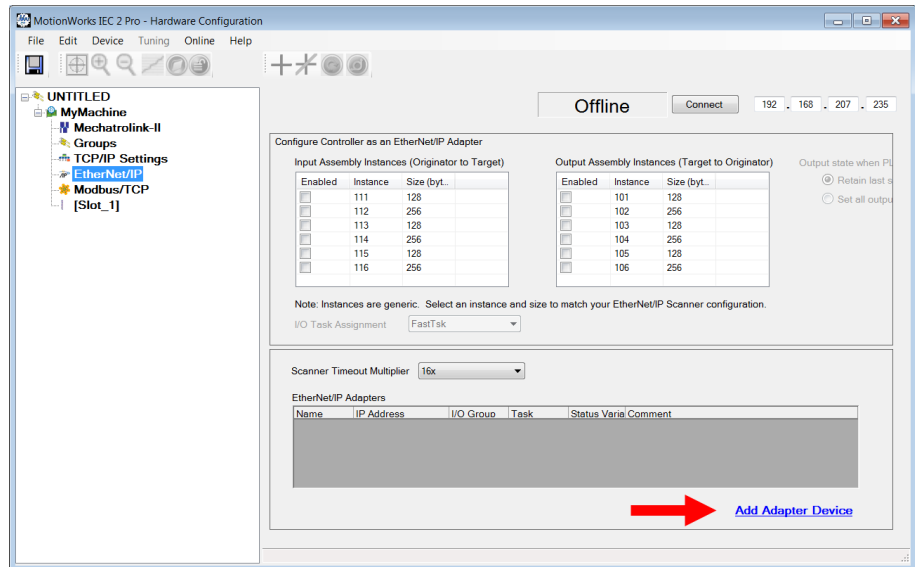

2. ▶ Select 'EtherNet/IP' and click at [Add Adapter Device].
⇒ The following dialog window is opened:

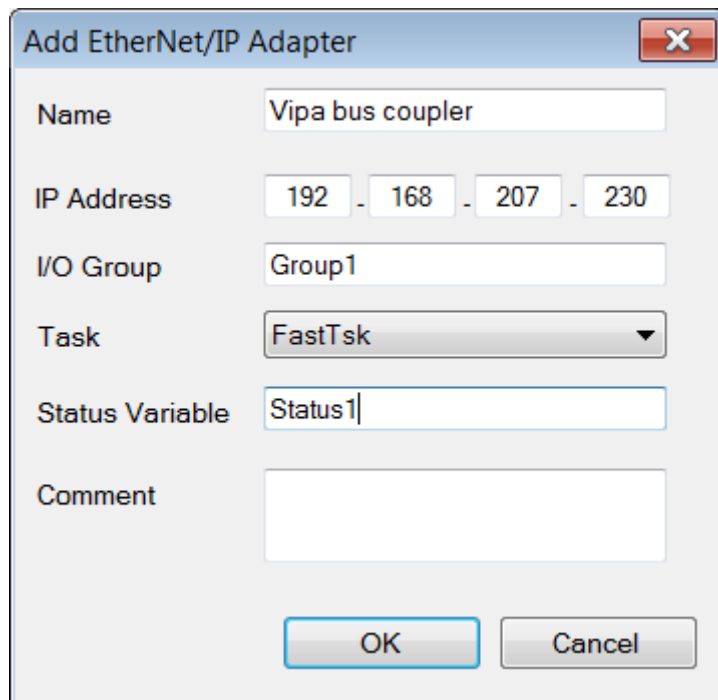

3. ▶ Please enter *Name*, *IP Address*, *I/O Group* and *Status Variable* and click at [OK]. When the configuration is saved, the status variable will be created in the global variable table under I/O group.
⇒ The dialog window is closed and the EtherNet/IP adapter is listed in the 'Hardware Configuration' below 'EtherNet/IP'.

4. ▶ Select 'VIPA bus coupler' and click at [Add Input/Output Assembly].

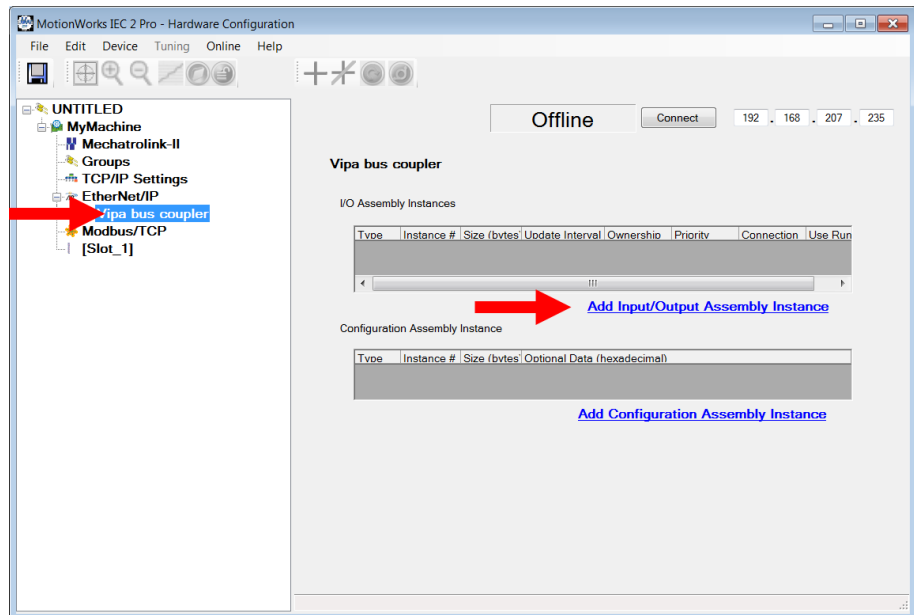

⇒ The following dialog window is opened:

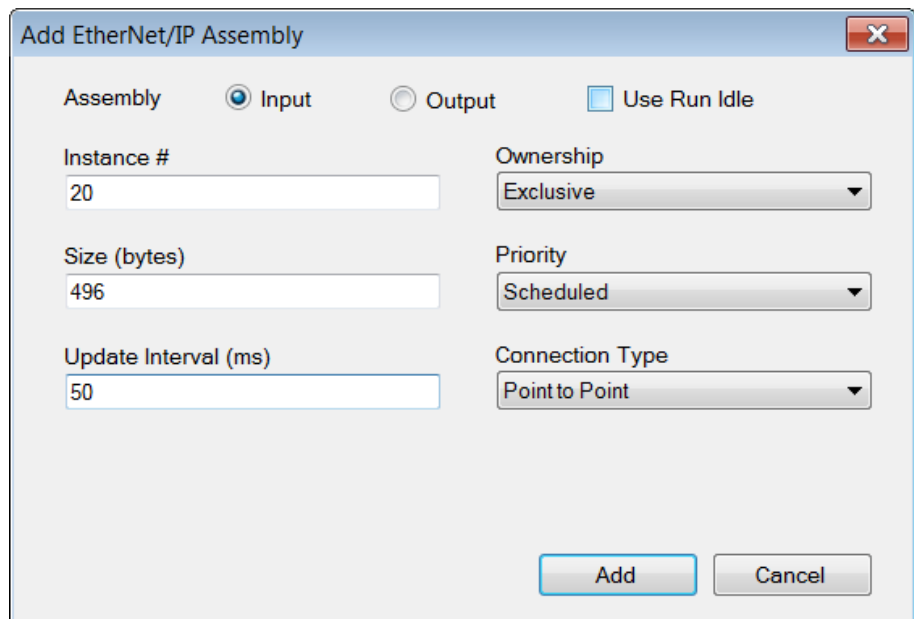

5. ▶ Set the following values and click at [Add]:

- Assembly: Input
- Instance: 20
- Size (byte): 496
- Update Interval (ms): 50
- Connection Type: Point to Point

⇒ The dialog is closed and the new instance is shown in the table.

6. Click at [Add Input/Output Assembly Instance] again.
⇒ The following dialog window is opened:

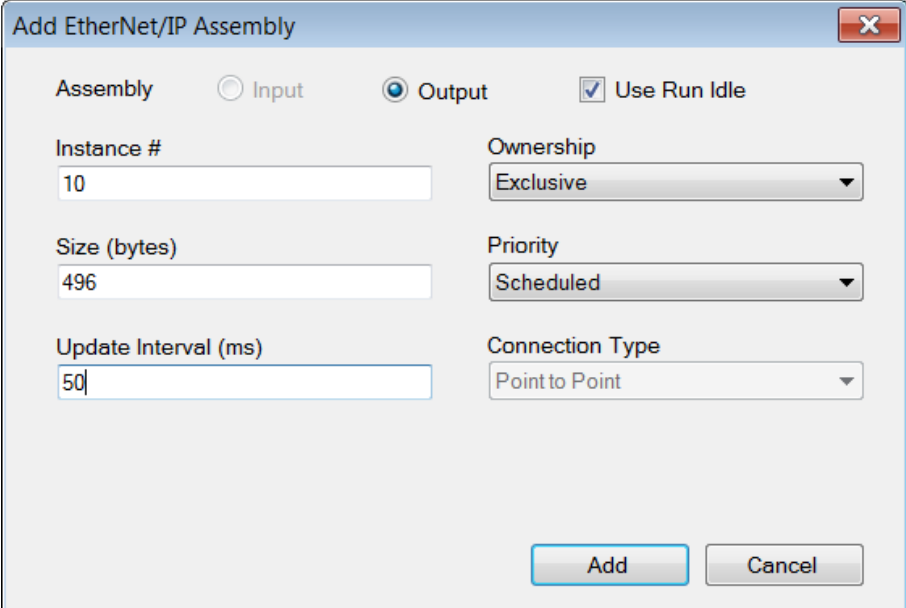

The dialog window is titled "Add EtherNet/IP Assembly". It features a close button in the top right corner. The "Assembly" section has two radio buttons: "Input" (unselected) and "Output" (selected). A checkbox labeled "Use Run Idle" is checked. The "Instance #" field contains the value "10". The "Size (bytes)" field contains "496". The "Update Interval (ms)" field contains "50". The "Ownership" dropdown menu is set to "Exclusive". The "Priority" dropdown menu is set to "Scheduled". The "Connection Type" dropdown menu is set to "Point to Point". At the bottom right, there are "Add" and "Cancel" buttons.

7. Set the following values and click at [Add]:
- Assembly: Output
 - Instance: 10
 - Size (byte): 496
 - Update Interval (ms): 50
- ⇒ The dialog is closed and the new instance is shown in the table.

8. Click at [Add Configuration Assembly Instance].

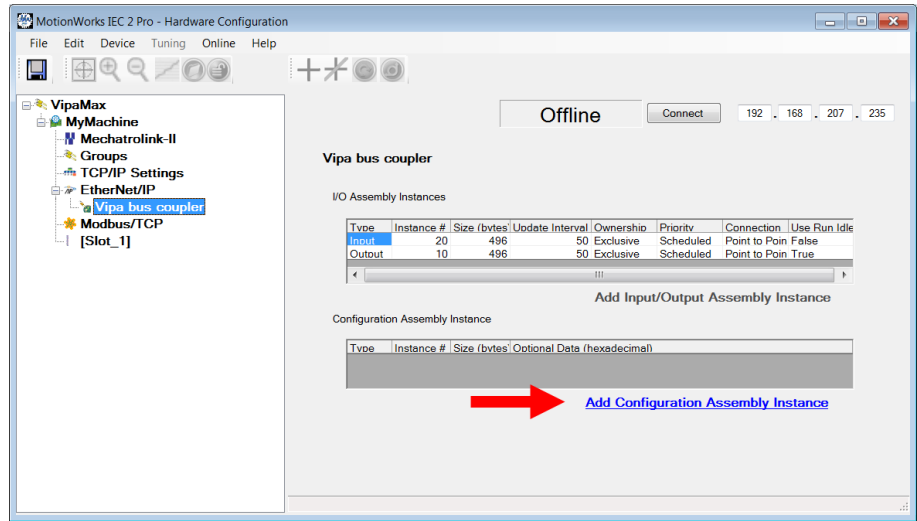

⇒ The following dialog window is opened:

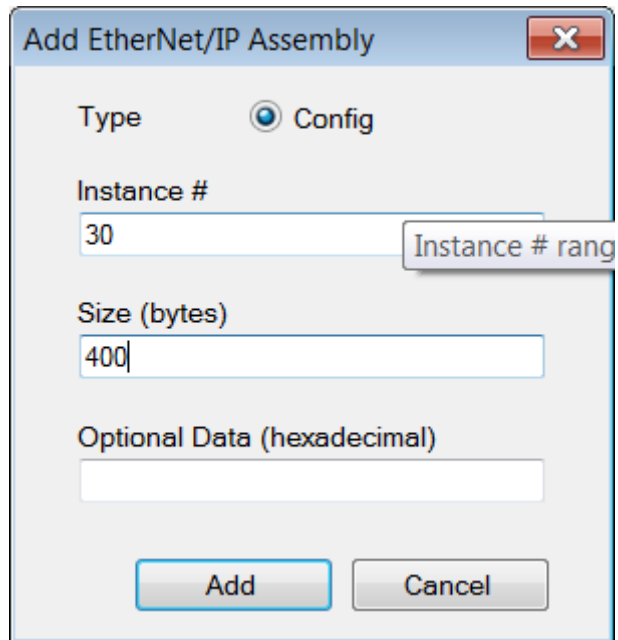

- 12.** Select '*Send offline configuration to controller then reboot controller*' and click at [Execute].

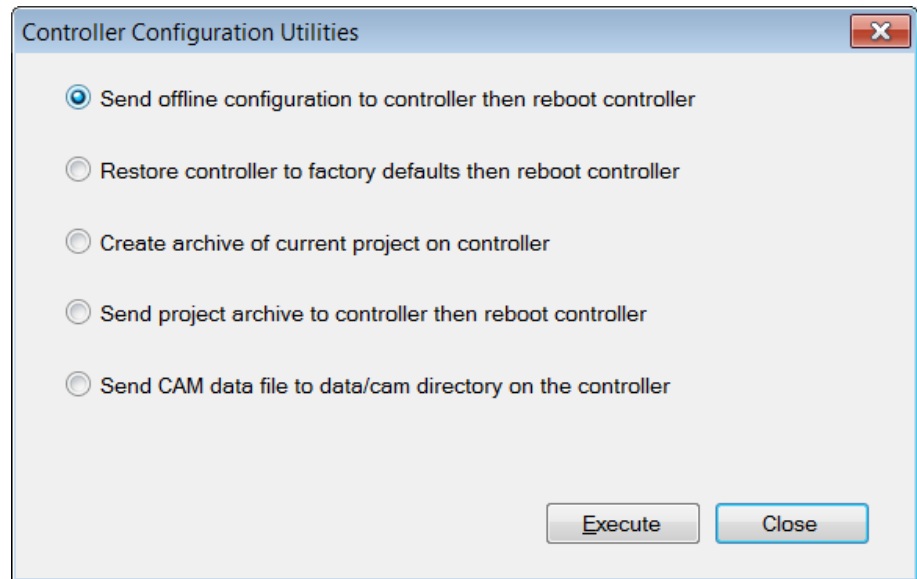

- 13.** Confirm the prompt for reboot with [Yes].

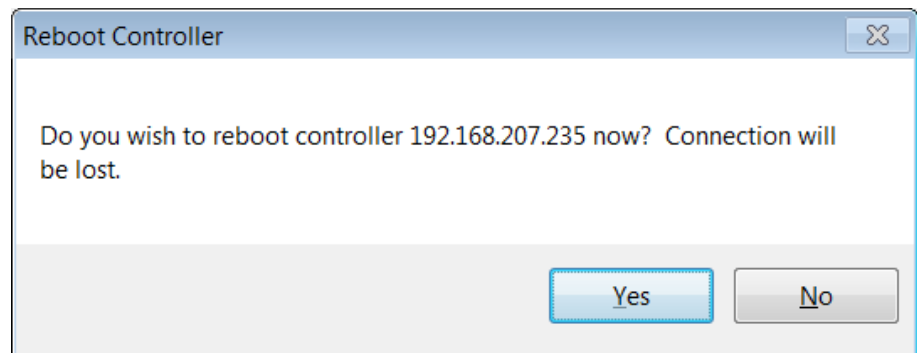

- 14.** Open the web page of the EtherNet/IP coupler.
15. Navigate to the register '*Parameter*'.

16. ➔ Activate the parameters 'Always send Transmit Address' and 'Discard a single connection on Timeout' and click at [Save].

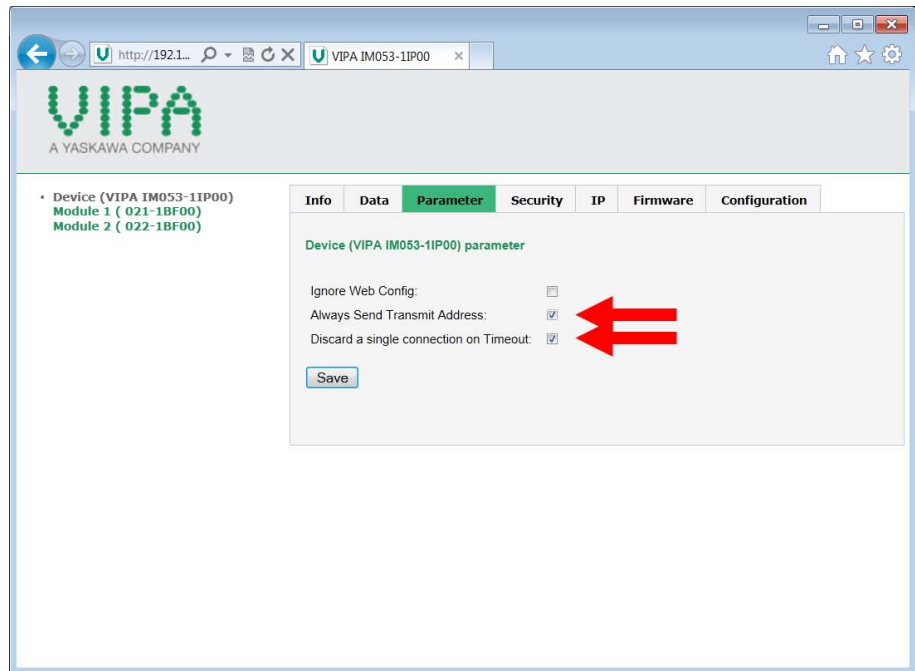

⇒ When the controller powers up, you can find the variable 'Status1' in the global variable table. The value 0x1000 indicates that the controller is connected to the bus coupler.

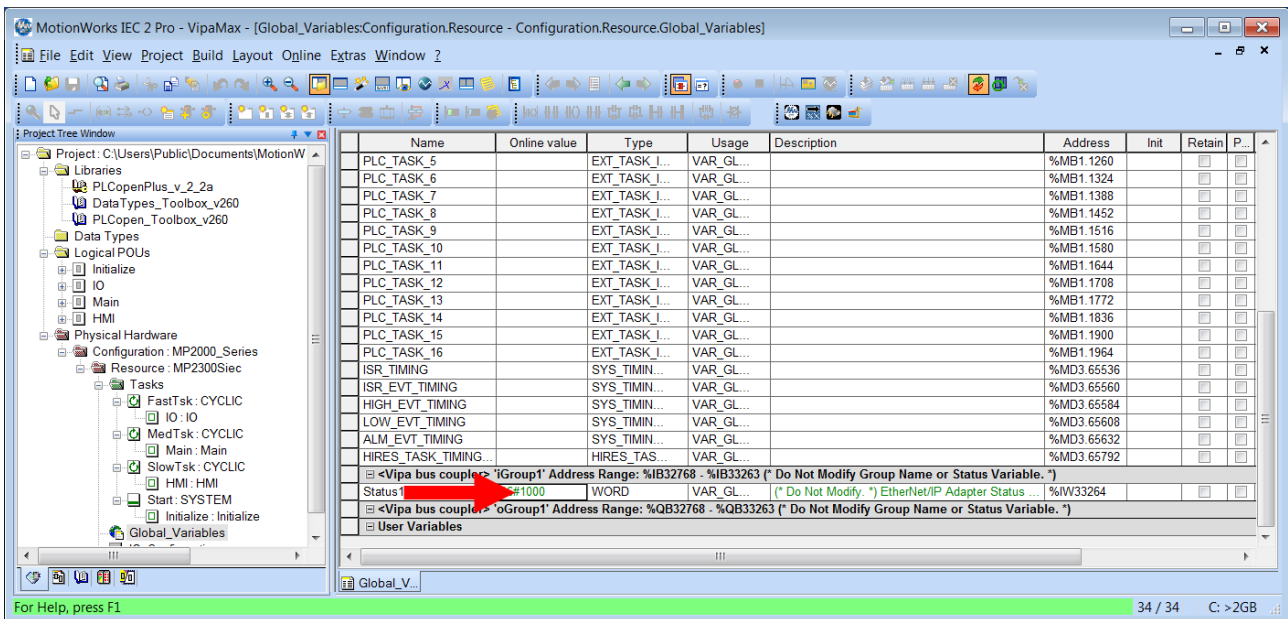

Examples > Configuration at a Rockwell scanner

4.9.2 Configuration at a Rockwell scanner

Configuration

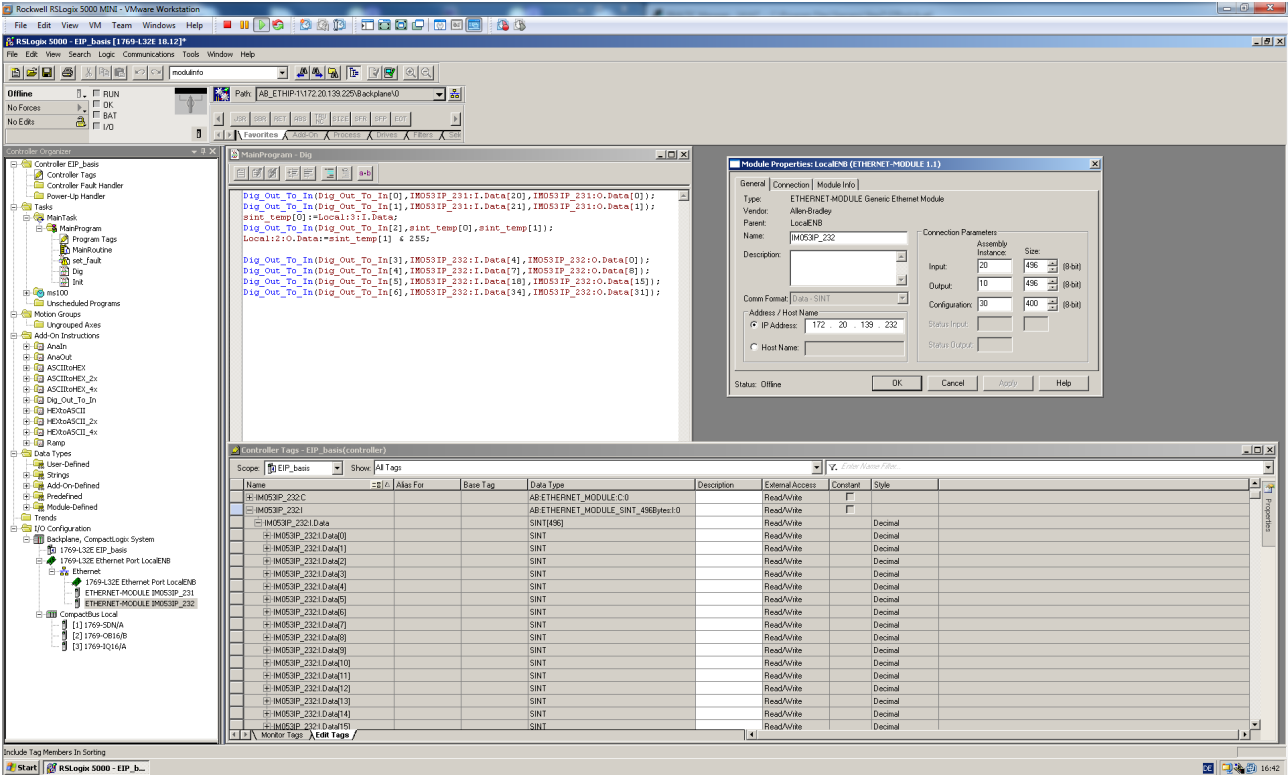

Here the following settings are necessary:

