

VIPA System SLIO

FM | 050-1BA10 | Manual

HB300 | FM | 050-1BA10 | en | 19-35

Counter module 5V differential 1x32Bit - FM 050



VIPA GmbH
Ohmstr. 4
91074 Herzogenaurach
Telephone: 09132-744-0
Fax: 09132-744-1864
Email: info@vipa.com
Internet: www.vipa.com

Table of contents

1	General	4
	1.1 Copyright © VIPA GmbH	4
	1.2 Über dieses Handbuch.....	5
	1.3 Safety information.....	6
2	Basics and mounting	7
	2.1 Safety information for users.....	7
	2.2 System conception.....	8
	2.2.1 Overview.....	8
	2.2.2 Components.....	9
	2.2.3 Accessories.....	11
	2.2.4 Hardware revision.....	12
	2.3 Dimensions.....	12
	2.4 Mounting periphery modules.....	15
	2.5 Wiring periphery modules.....	18
	2.6 Wiring power modules.....	20
	2.7 Demounting periphery modules.....	24
	2.7.1 Easy Maintenance.....	27
	2.8 Trouble shooting - LEDs.....	28
	2.9 Installation guidelines.....	29
	2.10 General data.....	31
3	Hardware description	33
	3.1 Properties.....	33
	3.2 Structure.....	33
	3.3 Technical data.....	36
4	Deployment	39
	4.1 Fast introduction.....	39
	4.2 In-/Output area.....	41
	4.2.1 Input area 8byte	41
	4.2.2 Output area 10byte	43
	4.3 Parameter data.....	44
	4.4 Counter - Functions.....	47
	4.5 Counter additional functions.....	52
	4.6 Diagnostic and interrupt.....	55

1 General

1.1 Copyright © VIPA GmbH

All Rights Reserved

This document contains proprietary information of VIPA and is not to be disclosed or used except in accordance with applicable agreements.

This material is protected by the copyright laws. It may not be reproduced, distributed, or altered in any fashion by any entity (either internal or external to VIPA), except in accordance with applicable agreements, contracts or licensing, without the express written consent of VIPA and the business management owner of the material.

For permission to reproduce or distribute, please contact: VIPA, Gesellschaft für Visualisierung und Prozessautomatisierung mbH Ohmstraße 4, D-91074 Herzogenaurach, Germany

Tel.: +49 9132 744 -0

Fax.: +49 9132 744-1864

E-Mail: info@vipa.de

<http://www.vipa.com>



Every effort has been made to ensure that the information contained in this document was complete and accurate at the time of publishing. Nevertheless, the authors retain the right to modify the information.

This customer document describes all the hardware units and functions known at the present time. Descriptions may be included for units which are not present at the customer site. The exact scope of delivery is described in the respective purchase contract.

EC Conformity Declaration

Hereby, VIPA GmbH declares that the products and systems are in compliance with the essential requirements and other relevant provisions. Conformity is indicated by the CE marking affixed to the product.

Conformity Information

For more information regarding CE marking and Declaration of Conformity (DoC), please contact your local VIPA customer service organization.

Trademarks

VIPA, SLIO, System 100V, System 200V, System 300V, System 300S, System 400V, System 500S and Commander Compact are registered trademarks of VIPA Gesellschaft für Visualisierung und Prozessautomatisierung mbH.

SPEED7 is a registered trademark of profichip GmbH.

SIMATIC, STEP, SINEC, TIA Portal, S7-300, S7-400 and S7-1500 are registered trademarks of Siemens AG.

Microsoft and Windows are registered trademarks of Microsoft Inc., USA.

Portable Document Format (PDF) and Postscript are registered trademarks of Adobe Systems, Inc.

All other trademarks, logos and service or product marks specified herein are owned by their respective companies.

Information product support

Contact your local VIPA Customer Service Organization representative if you wish to report errors or questions regarding the contents of this document. If you are unable to locate a customer service centre, contact VIPA as follows:

VIPA GmbH, Ohmstraße 4, 91074 Herzogenaurach, Germany

Telefax: +49 9132 744-1204

E-Mail: documentation@vipa.de

Technical support

Contact your local VIPA Customer Service Organization representative if you encounter problems with the product or have questions regarding the product. If you are unable to locate a customer service centre, contact VIPA as follows:

VIPA GmbH, Ohmstraße 4, 91074 Herzogenaurach, Germany

Tel.: +49 9132 744-1150 (Hotline)

E-Mail: support@vipa.de

1.2 Über dieses Handbuch

Objective and contents

This manual describes the FM 050-1BA10 of the System SLIO from VIPA. It contains a description of the construction, project implementation and usage.

Product	Order number	as of state:
		HW
FM 050	050-1BA10	01

Target audience

The manual is targeted at users who have a background in automation technology.

Structure of the manual

The manual consists of chapters. Every chapter provides a self-contained description of a specific topic.

Guide to the document

The following guides are available in the manual:

- An overall table of contents at the beginning of the manual
- References with page numbers

Availability

The manual is available in:

- printed form, on paper
- in electronic form as PDF-file (Adobe Acrobat Reader)

Icons Headings

Important passages in the text are highlighted by following icons and headings:

**DANGER!**

Immediate or likely danger. Personal injury is possible.

**CAUTION!**

Damages to property is likely if these warnings are not heeded.



Supplementary information and useful tips.

1.3 Safety information

Applications conforming with specifications

The system is constructed and produced for:

- communication and process control
- general control and automation tasks
- industrial applications
- operation within the environmental conditions specified in the technical data
- installation into a cubicle

**DANGER!**

This device is not certified for applications in

- in explosive environments (EX-zone)

Documentation

The manual must be available to all personnel in the

- project design department
- installation department
- commissioning
- operation

**CAUTION!**

The following conditions must be met before using or commissioning the components described in this manual:

- Hardware modifications to the process control system should only be carried out when the system has been disconnected from power!
- Installation and hardware modifications only by properly trained personnel.
- The national rules and regulations of the respective country must be satisfied (installation, safety, EMC ...)

Disposal

National rules and regulations apply to the disposal of the unit!

2 Basics and mounting

2.1 Safety information for users

Handling of electrostatic sensitive modules

VIPA modules make use of highly integrated components in MOS-Technology. These components are extremely sensitive to over-voltages that can occur during electrostatic discharges. The following symbol is attached to modules that can be destroyed by electrostatic discharges.



The Symbol is located on the module, the module rack or on packing material and it indicates the presence of electrostatic sensitive equipment. It is possible that electrostatic sensitive equipment is destroyed by energies and voltages that are far less than the human threshold of perception. These voltages can occur where persons do not discharge themselves before handling electrostatic sensitive modules and they can damage components thereby, causing the module to become inoperable or unusable. Modules that have been damaged by electrostatic discharges can fail after a temperature change, mechanical shock or changes in the electrical load. Only the consequent implementation of protection devices and meticulous attention to the applicable rules and regulations for handling the respective equipment can prevent failures of electrostatic sensitive modules.

Shipping of modules

Modules must be shipped in the original packing material.

Measurements and alterations on electrostatic sensitive modules

When you are conducting measurements on electrostatic sensitive modules you should take the following precautions:

- Floating instruments must be discharged before use.
- Instruments must be grounded.

Modifying electrostatic sensitive modules you should only use soldering irons with grounded tips.



CAUTION!

Personnel and instruments should be grounded when working on electrostatic sensitive modules.

2.2 System conception

2.2.1 Overview

System SLIO is a modular automation system for assembly on a 35mm mounting rail. By means of the peripheral modules with 2, 4 or 8 channels this system may properly be adapted matching to your automation tasks. The wiring complexity is low, because the supply of the DC 24V power section is integrated to the backplane bus and defective modules may be replaced with standing wiring. By deployment of the power modules in contrasting colors within the system, further isolated areas may be defined for the DC 24V power section supply, respectively the electronic power supply may be extended with 2A.

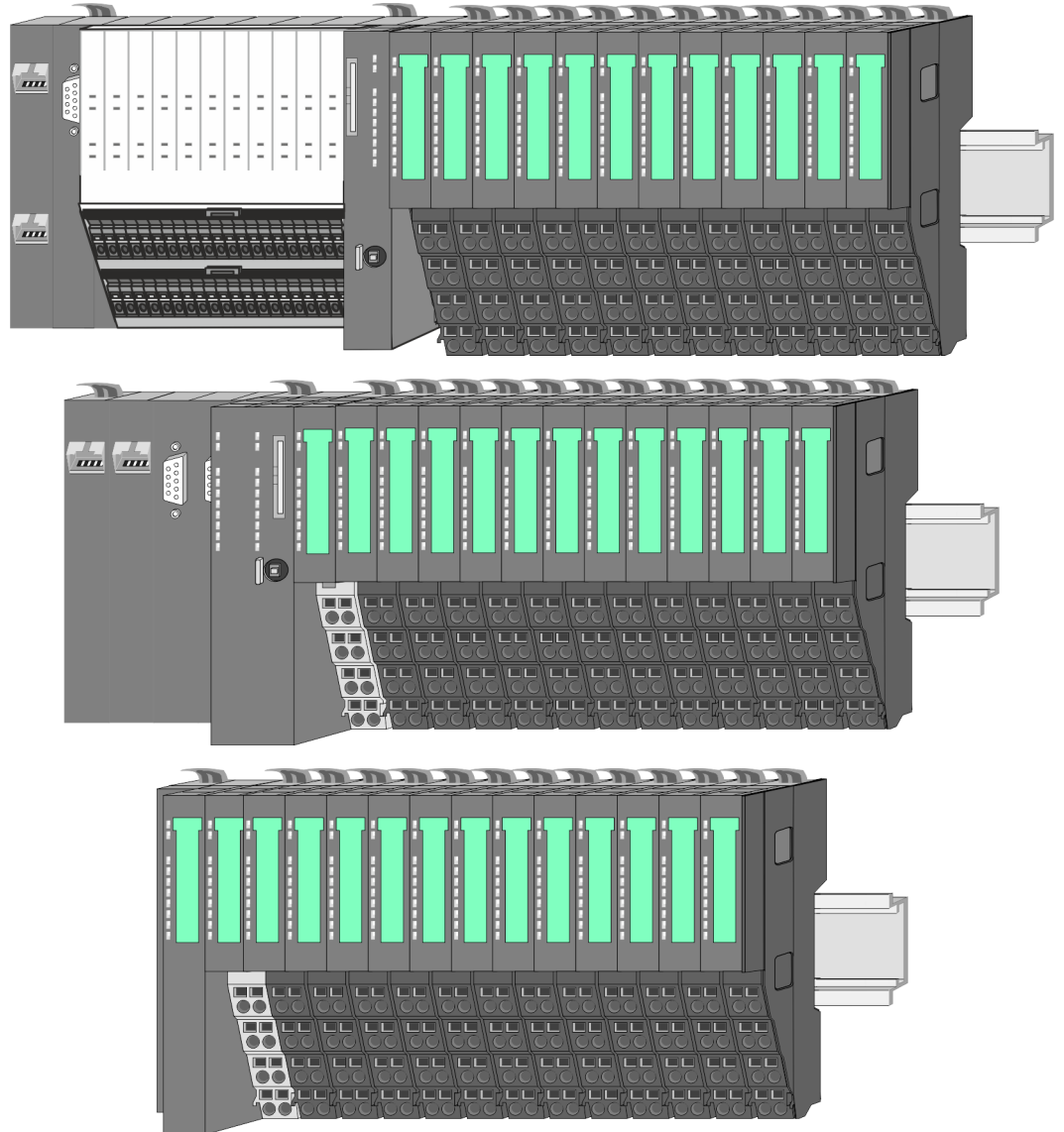

2.2.2 Components

- CPU (head module)
- Bus coupler (head module)
- Line extension
- Periphery modules
- Accessories



CAUTION!

Only modules of VIPA may be combined. A mixed operation with third-party modules is not allowed!

CPU 01xC

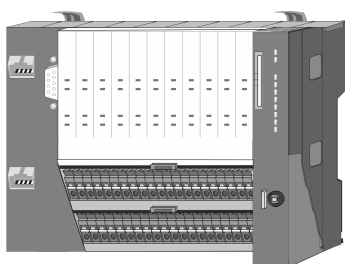

With this CPU 01xC, the CPU electronic, input/output components and power supply are integrated to one casing. In addition, up to 64 periphery modules of the System SLIO can be connected to the backplane bus. As head module via the integrated power supply CPU electronic and the I/O components are power supplied as well as the electronic of the connected periphery modules. To connect the power supply of the I/O components and for DC 24V power supply of via backplane bus connected peripheral modules, the CPU has removable connectors. By installing of up to 64 periphery modules at the backplane bus, these are electrically connected, this means these are assigned to the backplane bus, the electronic modules are power supplied and each periphery module is connected to the DC 24V power section supply.

CPU 01x



With this CPU 01x, the CPU electronic and power supply are integrated to one casing. As head module, via the integrated power module for power supply, CPU electronic and the electronic of the connected periphery modules are supplied. The DC 24 power section supply for the linked periphery modules is established via a further connection of the power module. By installing of up to 64 periphery modules at the backplane bus, these are electrically connected, this means these are assigned to the backplane bus, the electronic modules are power supplied and each periphery module is connected to the DC 24V power section supply.



CAUTION!

CPU part and power module may not be separated!
Here you may only exchange the electronic module!

Bus coupler

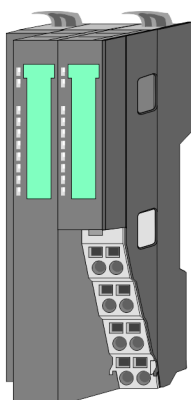

With a bus coupler bus interface and power module is integrated to one casing. With the bus interface you get access to a subordinated bus system. As head module, via the integrated power module for power supply, bus interface and the electronic of the connected periphery modules are supplied. The DC 24 power section supply for the linked periphery modules is established via a further connection of the power module. By installing of up to 64 periphery modules at the bus coupler, these are electrically connected, this means these are assigned to the backplane bus, the electronic modules are power supplied and each periphery module is connected to the DC 24V power section supply.



CAUTION!

Bus interface and power module may not be separated!
Here you may only exchange the electronic module!

Line extension

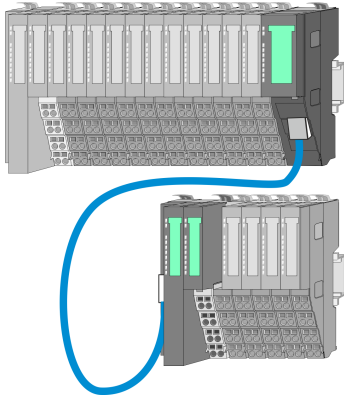

In the System SLIO there is the possibility to place up to 64 modules in on line. By means of the line extension you can divide this line into several lines. Here you have to place a line extension master at each end of a line and the subsequent line has to start with a line extension slave. Master and slave are to be connected via a special connecting cable. In this way, you can divide a line on up to 5 lines. For each line extension the maximum number of pluggable modules at the System SLIO bus is decreased by 1. To use the line extension no special configuration is required.

Periphery modules

Each periphery module consists of a *terminal* and an *electronic module*.

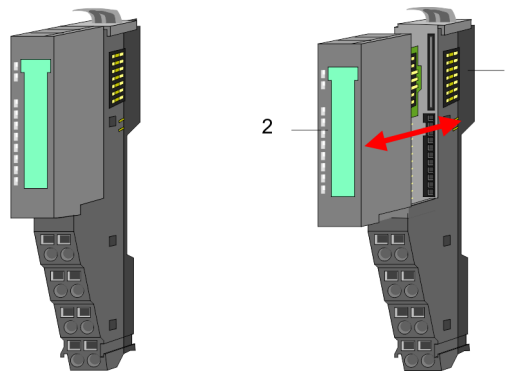

- 1 Terminal module
- 2 Electronic module

Terminal module

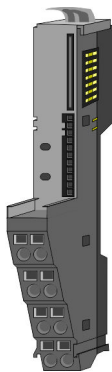

The *terminal* module serves to carry the electronic module, contains the backplane bus with power supply for the electronic, the DC 24V power section supply and the staircase-shaped terminal for wiring. Additionally the terminal module has a locking system for fixing at a mounting rail. By means of this locking system your SLIO system may be assembled outside of your switchgear cabinet to be later mounted there as whole system.

Electronic module

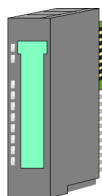

The functionality of a SLIO periphery module is defined by the *electronic* module, which is mounted to the terminal module by a sliding mechanism. With an error the defective module may be exchanged for a functional module with standing installation. At the front side there are LEDs for status indication. For simple wiring each module shows a corresponding connection diagram at the front and at the side.

2.2.3 Accessories

Shield bus carrier



The shield bus carrier (order no.: 000-0AB00) serves to carry the shield bus (10mm x 3mm) to connect cable shields. Shield bus carriers, shield bus and shield fixings are not in the scope of delivery. They are only available as accessories. The shield bus carrier is mounted underneath the terminal of the terminal module. With a flat mounting rail for adaptation to a flat mounting rail you may remove the spacer of the shield bus carrier.

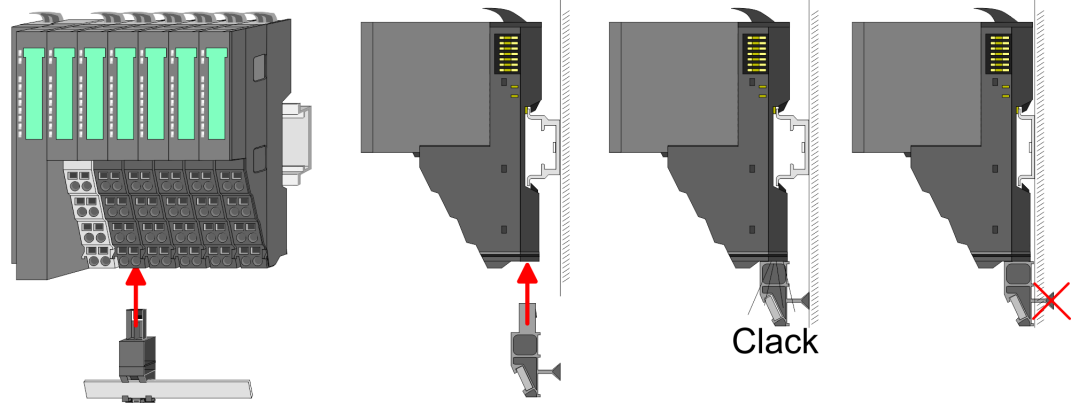

Bus cover

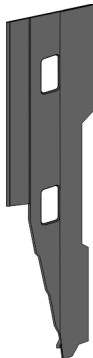

With each head module, to protect the backplane bus connectors, there is a mounted bus cover in the scope of delivery. You have to remove the bus cover of the head module before mounting a System SLIO module. For the protection of the backplane bus connector you always have to mount the bus cover at the last module of your system again. The bus cover has the order no. 000-0AA00.

Coding pins



There is the possibility to fix the assignment of electronic and terminal module. Here coding pins (order number 000-0AC00) from VIPA can be used. The coding pin consists of a coding jack and a coding plug. By combining electronic and terminal module with coding pin, the coding jack remains in the electronic module and the coding plug in the terminal module. This ensures that after replacing the electronics module just another electronic module can be plugged with the same encoding.

2.2.4 Hardware revision

Hardware revision on the front

- The hardware revision version is printed on every System SLIO module.
- Since a System SLIO module consists of a terminal and electronics module, you will find a hardware revision on each of them.
- Authoritative for the hardware revision of a System SLIO module is the hardware revision of the electronic module. This is always located under the labeling strip of the corresponding electronic module.
- On modules without labeling strip, such as CPUs, the hardware revision is printed on the front.

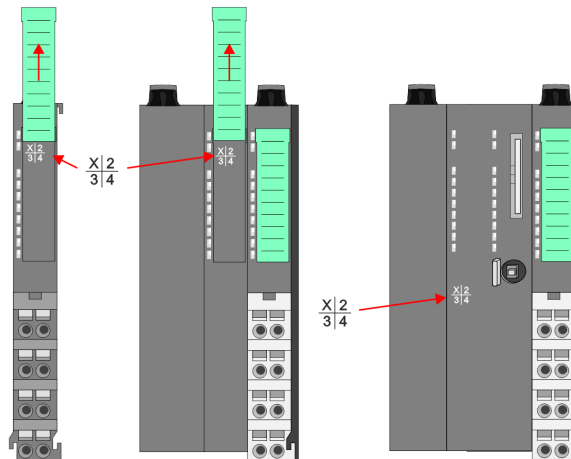

The example here shows the hardware revision 1. 1 is marked with 'X'.

Hardware revision via web server

On the CPUs and some bus couplers, you can output the hardware revision 'HW Revision' via the integrated web server.

2.3 Dimensions

Dimensions CPU 01xC

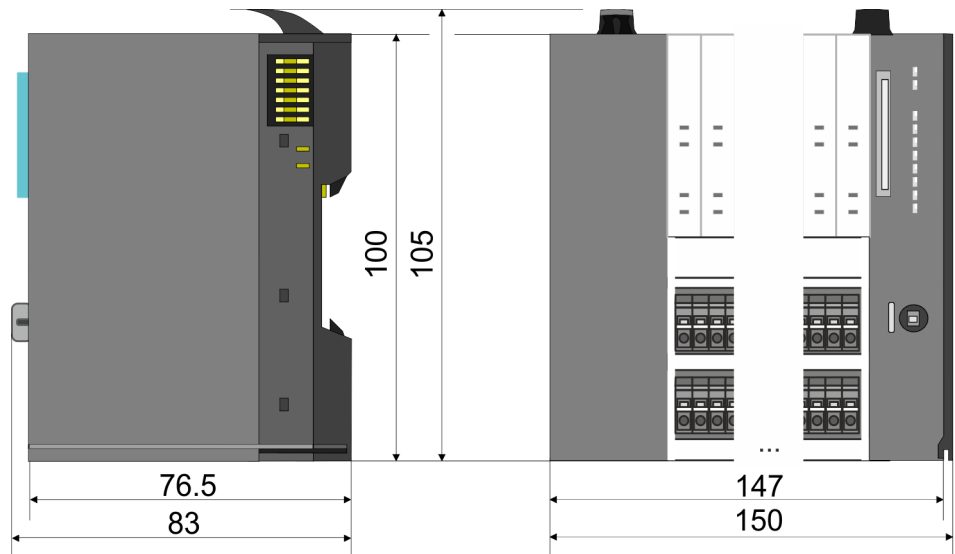

Dimensions CPU 01x

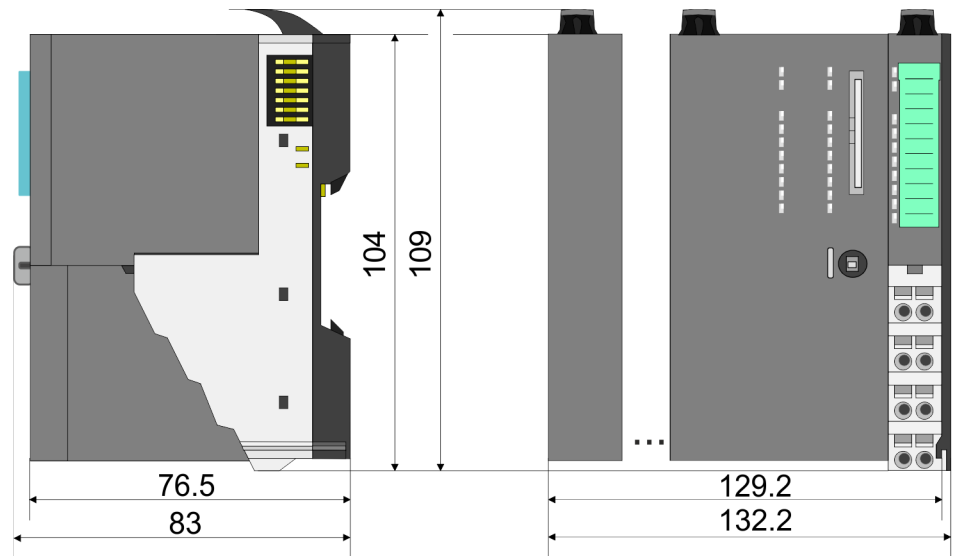

Dimensions bus coupler and line extension slave

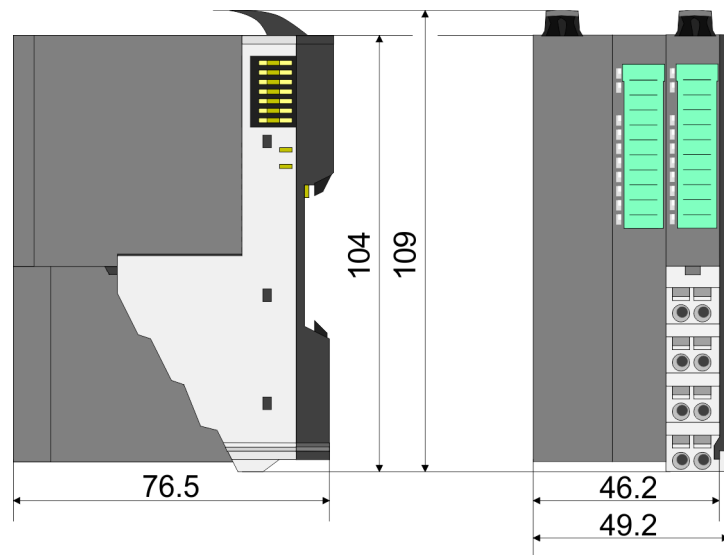

Dimensions line extension master

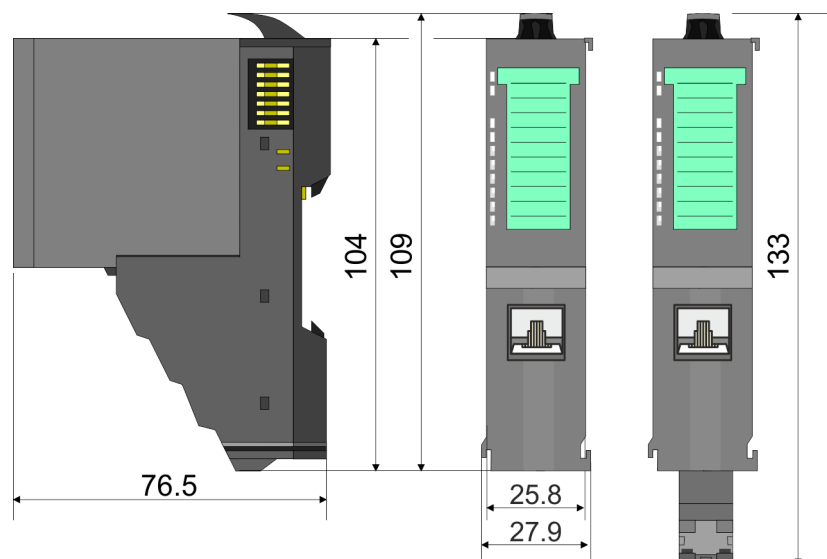

Dimensions

Dimension periphery module

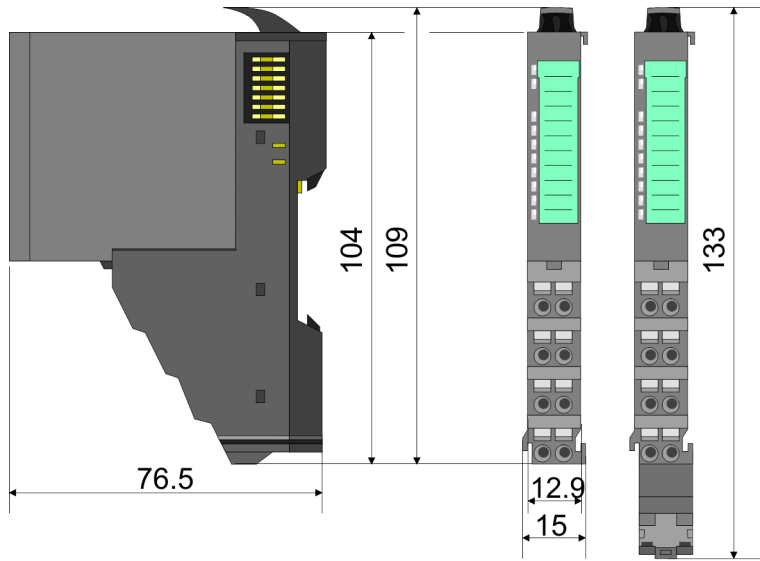

Dimensions electronic module

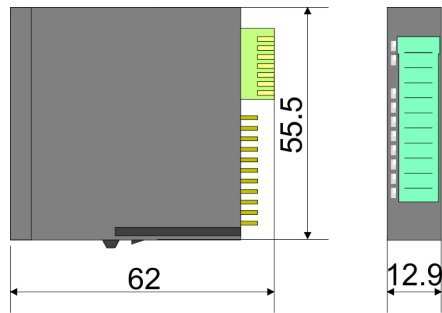

Dimensions in mm

2.4 Mounting periphery modules



Requirements for UL compliance use

- Use for power supply exclusively SELV/PELV power supplies.
- The System SLIO must be installed and operated in a housing according to IEC 61010-1 9.3.2 c).

There is a locking lever at the top side of the module. For mounting and demounting this locking lever is to be turned upwards until this engages. For mounting place the module to the module installed before and push the module to the mounting rail guided by the strips at the upper and lower side of the module. The module is fixed to the mounting rail by pushing downward the locking lever. The modules may either separately be mounted to the mounting rail or as block. Here is to be considered that each locking lever is opened. The modules are each installed on a mounting rail. The electronic and power section supply are connected via the backplane bus. Up to 64 modules may be mounted. Please consider here that the sum current of the electronic power supply does not exceed the maximum value of 3A. By means of the power module 007-1AB10 the current of the electronic power supply may be expanded accordingly.

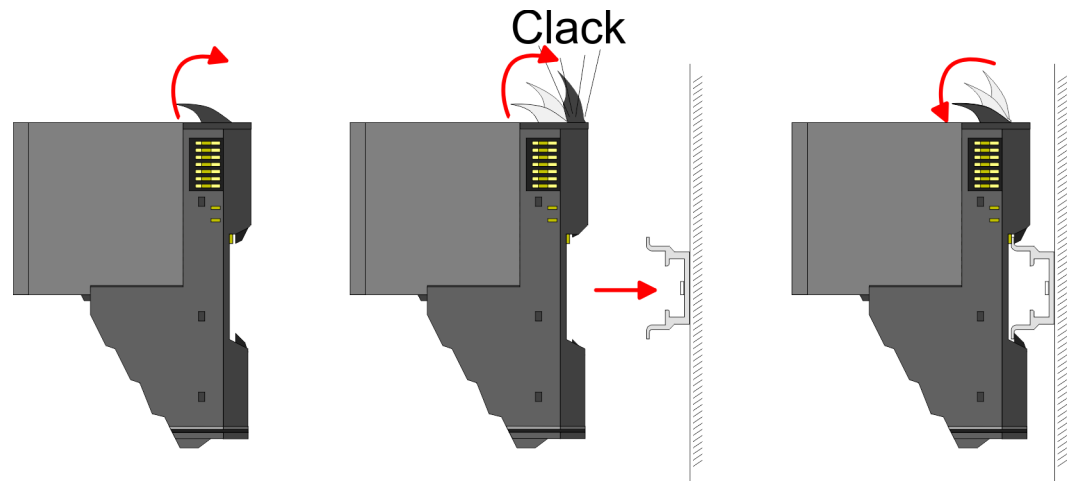

Terminal and electronic module

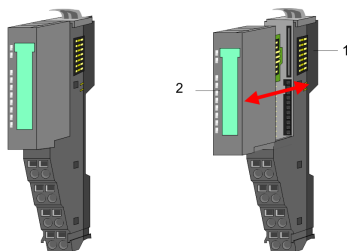

Each periphery module consists of a *terminal* and an *electronic module*.

- 1 Terminal module
- 2 Electronic module

For the exchange of a electronic module, the electronic module may be pulled forward after pressing the unlocking lever at the lower side of the module. For installation plug the electronic module guided by the strips at the lower side until this engages audible to the terminal module.

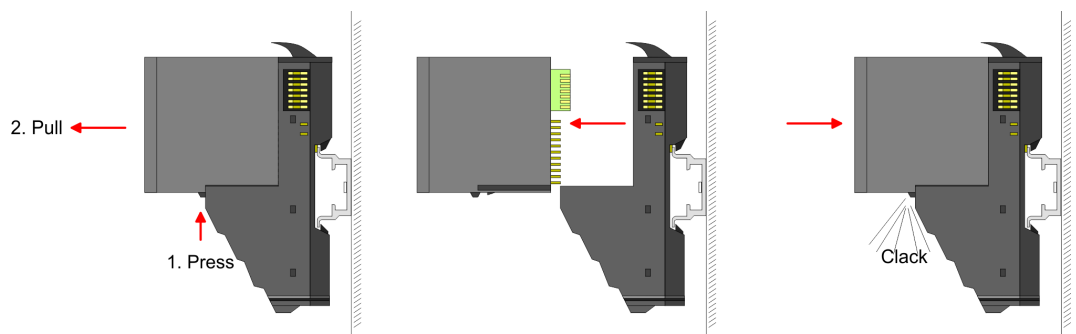

Coding



There is the possibility to fix the assignment of electronic and terminal module. Here coding pins (order number 000-0AC00) from VIPA can be used. The coding pin consists of a coding jack and a coding plug. By combining electronic and terminal module with coding pin, the coding jack remains in the electronic module and the coding plug in the terminal module. This ensures that after replacing the electronics module just another electronic module can be plugged with the same encoding.

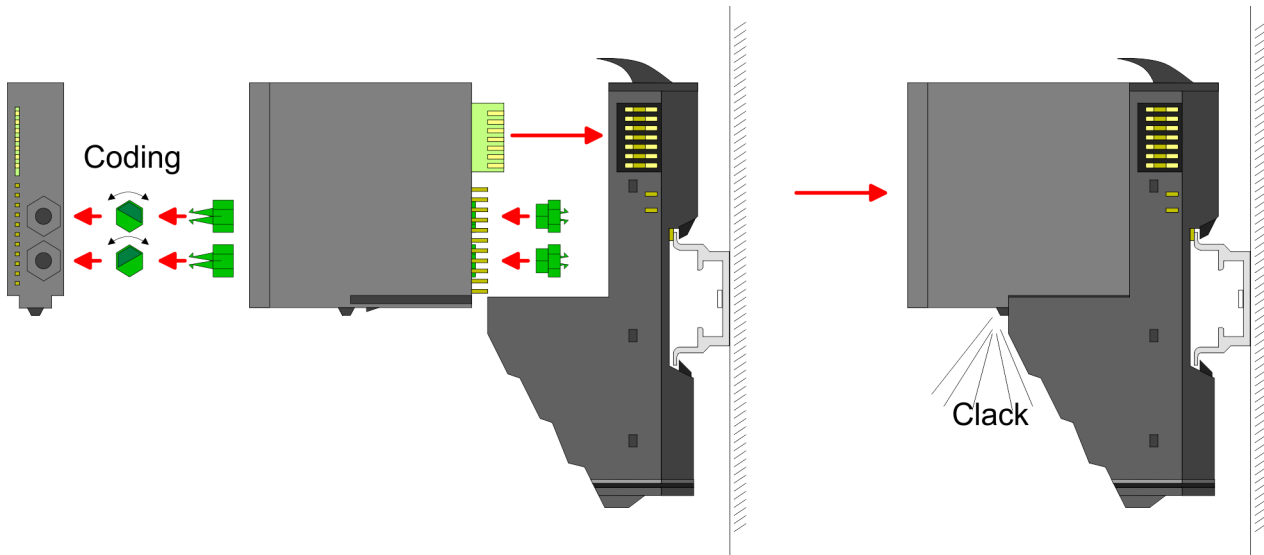

Each electronic module has on its back 2 coding sockets for coding jacks. Due to the characteristics, with the coding jack 6 different positions can be plugged, each. Thus there are 36 possible combinations for coding with the use of both coding sockets.

1. ➤ Plug, according to your coding, 2 coding jacks in the coding sockets of your electronic module until they lock
2. ➤ Now plug the according coding plugs into the coding jacks.
3. ➤ To fix the coding put both the electronic and terminal module together until they lock



CAUTION!

Please consider that when replacing an already coded electronic module, this is always be replaced by an electronic module with the same coding.

Even with an existing coding on the terminal module, you can plug an electronic module without coding. The user is responsible for the correct usage of the coding pins. VIPA assumes no liability for incorrectly attached electronic modules or for damages which arise due to incorrect coding!

Mounting periphery modules

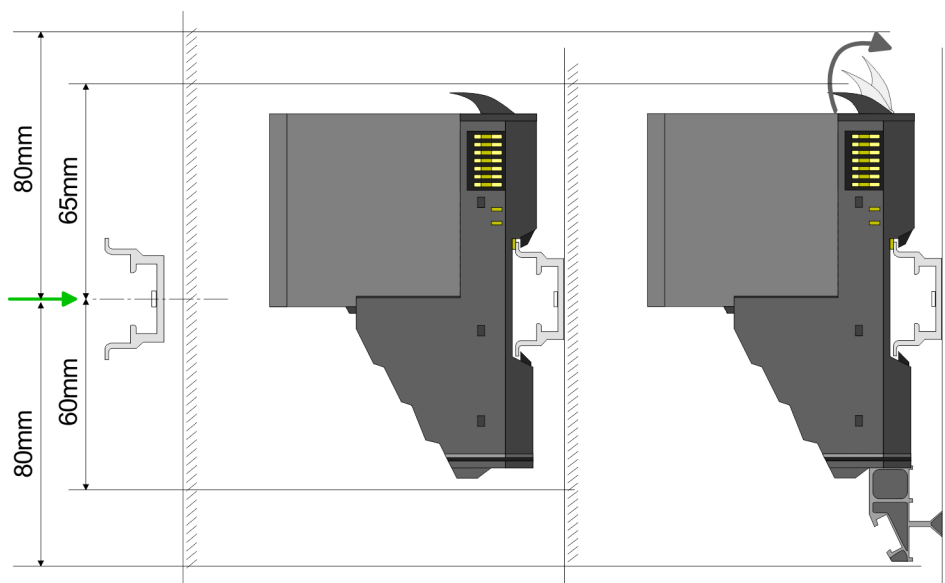

1. ➤ Mount the mounting rail! Please consider that a clearance from the middle of the mounting rail of at least 80mm above and 60mm below, respectively 80mm by deployment of shield bus carriers, exist.
2. ➤ Mount your head module such as CPU or field bus coupler.
3. ➤ Before mounting the periphery modules you have to remove the bus cover at the right side of the Head module by pulling it forward. Keep the cover for later mounting.

Clack

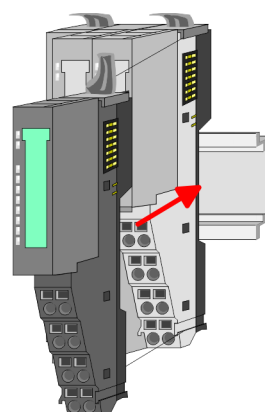
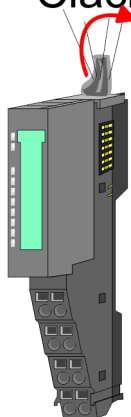

4. ➤ For mounting turn the locking lever of the module upward until it engages.
5. ➤ For mounting place the module to the module installed before and push the module to the mounting rail guided by the strips at the upper and lower side of the module.
6. ➤ Turn the locking lever of the periphery module downward, again.

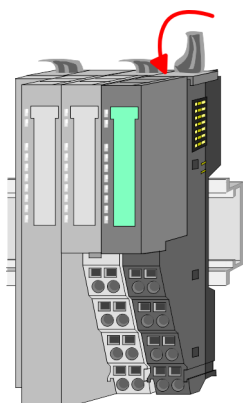

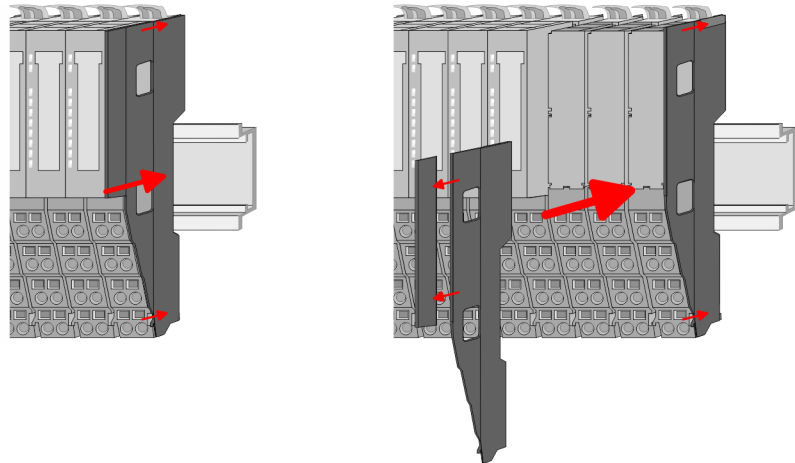

7. ➤ After mounting the whole system, to protect the backplane bus connectors at the last module you have to mount the bus cover, now. If the last module is a clamp module, for adaptation the upper part of the bus cover is to be removed.

2.5 Wiring periphery modules

Terminal module terminals



CAUTION!

Do not connect hazardous voltages!

If this is not explicitly stated in the corresponding module description, hazardous voltages are not allowed to be connected to the corresponding terminal module!

With wiring the terminal modules, terminals with spring clamp technology are used for wiring. The spring clamp technology allows quick and easy connection of your signal and supply lines. In contrast to screw terminal connections this type of connection is vibration proof.

Data

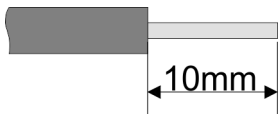

U_{max}	240V AC / 30V DC
I_{max}	10A
Cross section	0.08 ... 1.5mm ² (AWG 28 ... 16)
Stripping length	10mm

Wiring procedure

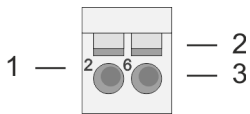

- 1 Pin number at the connector
- 2 Opening for screwdriver
- 3 Connection hole for wire

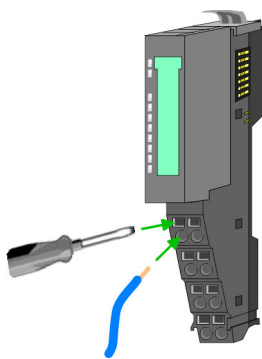
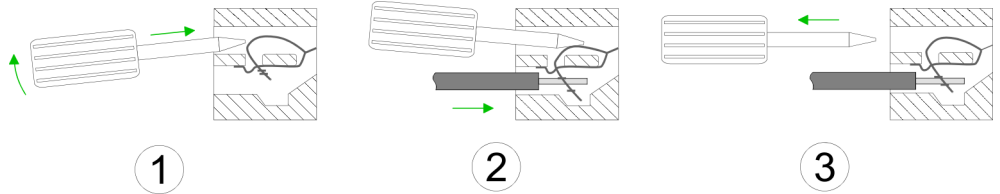

- 1. Insert a suited screwdriver at an angle into the square opening as shown. Press and hold the screwdriver in the opposite direction to open the contact spring.
- 2. Insert the stripped end of wire into the round opening. You can use wires with a cross section of 0.08mm² up to 1.5mm²
- 3. By removing the screwdriver, the wire is securely fixed via the spring contact to the terminal.

Shield attachment

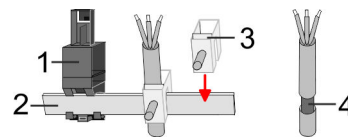

- 1 Shield bus carrier
- 2 Shield bus (10mm x 3mm)
- 3 Shield clamp
- 4 Cable shield

To attach the shield the mounting of shield bus carriers are necessary. The shield bus carrier (available as accessory) serves to carry the shield bus to connect cable shields.

- 1. Each System SLIO module has a carrier hole for the shield bus carrier. Push the shield bus carrier, until they engage into the module. With a flat mounting rail for adaptation to a flat mounting rail you may remove the spacer of the shield bus carrier.
- 2. Put your shield bus into the shield bus carrier.

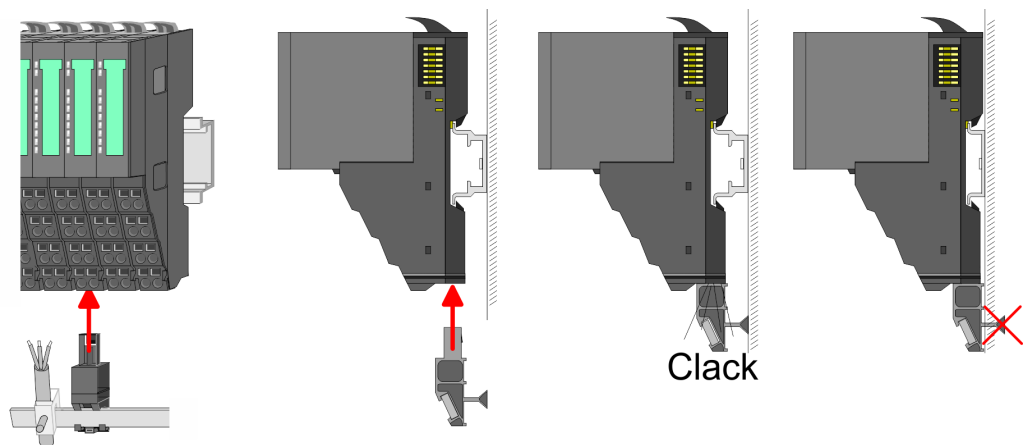

- 3. Attach the cables with the accordingly stripped cable screen and fix it by the shield clamp with the shield bus.

2.6 Wiring power modules

Terminal module terminals

Power modules are either integrated to the head module or may be installed between the periphery modules. With power modules, terminals with spring clamp technology are used for wiring. The spring clamp technology allows quick and easy connection of your signal and supply lines. In contrast to screw terminal connections this type of connection is vibration proof.

Data

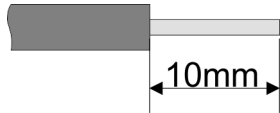

U_{max} 30V DC
 I_{max} 10A
 Cross section 0.08 ... 1.5mm² (AWG 28 ... 16)
 Stripping length 10mm

Wiring procedure

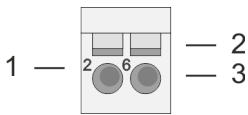

- 1 Pin number at the connector
- 2 Opening for screwdriver
- 3 Connection hole for wire

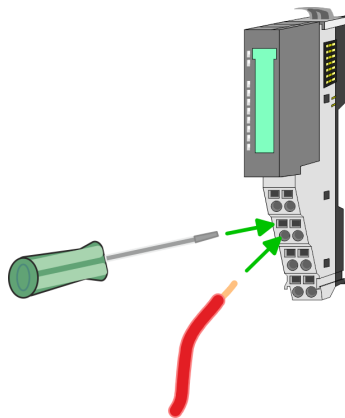
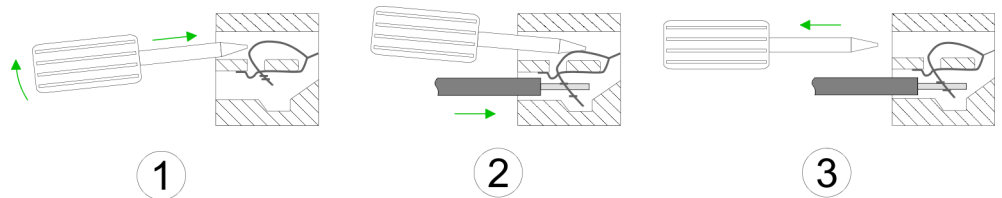

1. Insert a suited screwdriver at an angle into the square opening as shown. Press and hold the screwdriver in the opposite direction to open the contact spring.
2. Insert the stripped end of wire into the round opening. You can use wires with a cross section of 0.08mm² up to 1.5mm²
3. By removing the screwdriver, the wire is securely fixed via the spring contact to the terminal.

Standard wiring

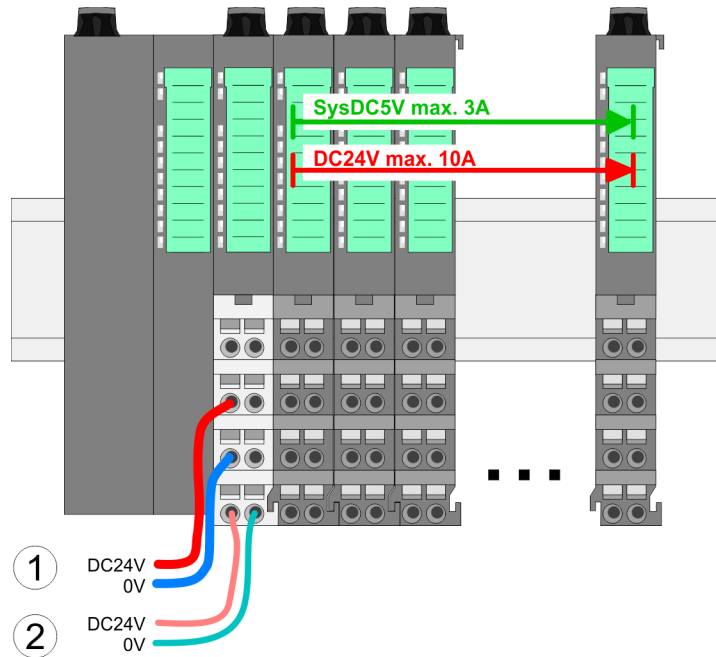

- (1) DC 24V for power section supply I/O area (max. 10A)
- (2) DC 24V for electronic power supply bus coupler and I/O area

PM - Power module

For wires with a core cross-section of 0.08mm² up to 1.5mm².

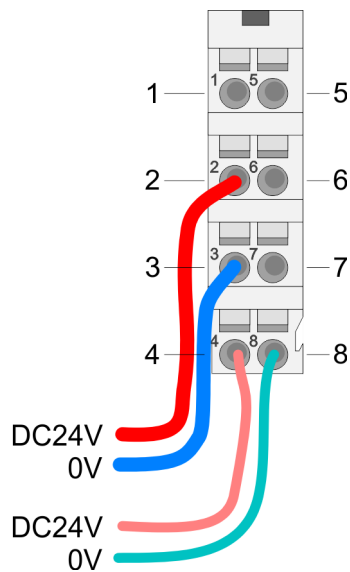

Pos.	Function	Type	Description
1	---	---	not connected
2	DC 24V	I	DC 24V for power section supply
3	0V	I	GND for power section supply
4	Sys DC 24V	I	DC 24V for electronic section supply
5	---	---	not connected
6	DC 24V	I	DC 24V for power section supply
7	0V	I	GND for power section supply
8	Sys 0V	I	GND for electronic section supply

I: Input



CAUTION!

Since the power section supply is not internally protected, it is to be externally protected with a fuse, which corresponds to the maximum current. This means max. 10A is to be protected by a 10A fuse (fast) respectively by a line circuit breaker 10A characteristics Z!



The electronic power section supply is internally protected against higher voltage by fuse. The fuse is within the power module. If the fuse releases, its electronic module must be exchanged!

Fusing

- The power section supply is to be externally protected with a fuse, which corresponds to the maximum current. This means max. 10A is to be protected with a 10A fuse (fast) respectively by a line circuit breaker 10A characteristics Z!
- It is recommended to externally protect the electronic power supply for head modules and I/O area with a 2A fuse (fast) respectively by a line circuit breaker 2A characteristics Z.
- The electronic power supply for the I/O area of the power module 007-1AB10 should also be externally protected with a 1A fuse (fast) respectively by a line circuit breaker 1A characteristics Z.

State of the electronic power supply via LEDs

After PowerON of the System SLIO the LEDs RUN respectively MF get on so far as the sum current does not exceed 3A. With a sum current greater than 3A the LEDs may not be activated. Here the power module with the order number 007-1AB10 is to be placed between the peripheral modules.

Deployment of the power modules

- If the 10A for the power section supply is no longer sufficient, you may use the power module from VIPA with the order number 007-1AB00. So you have also the possibility to define isolated groups.
- The power module with the order number 007-1AB10 is to be used if the 3A for the electronic power supply at the backplane bus is no longer sufficient. Additionally you get an isolated group for the DC 24V power section supply with max. 4A.
- By placing the power module 007-1AB10 at the following backplane bus modules may be placed with a sum current of max. 2A. Afterwards a power module is to be placed again. To secure the power supply, the power modules may be mixed used.

Power module 007-1AB00

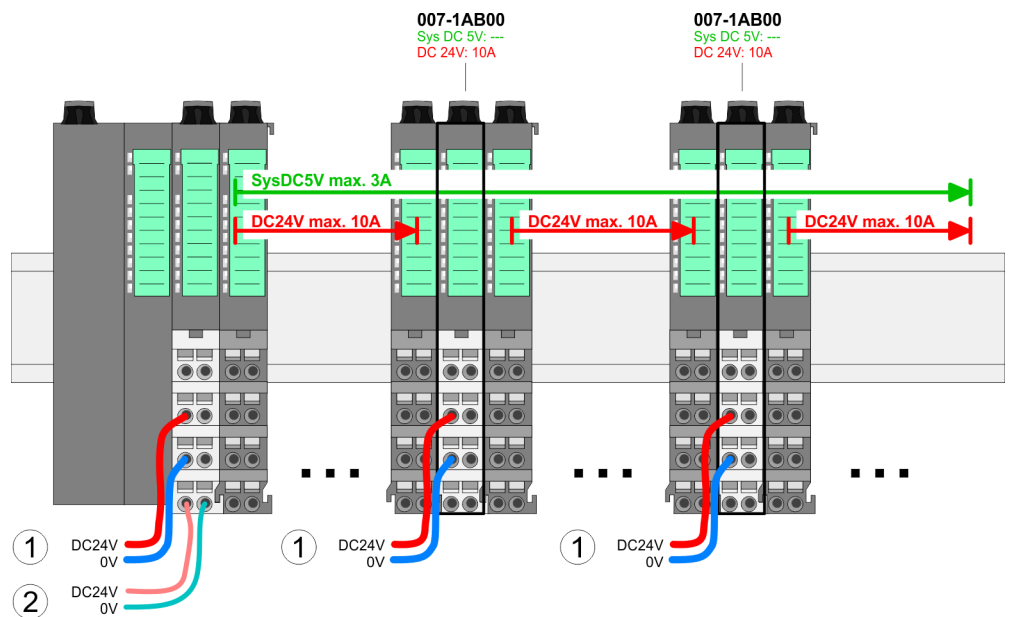

Power module 007-1AB10

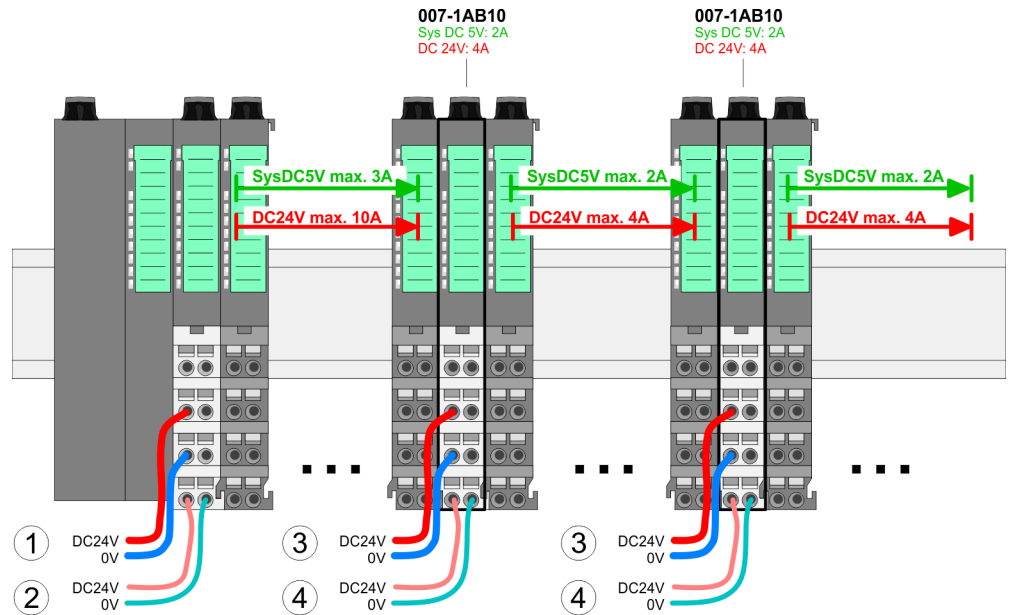

- (1) DC 24V for power section supply I/O area (max. 10A)
- (2) DC 24V for electronic power supply bus coupler and I/O area
- (3) DC 24V for power section supply I/O area (max. 4A)
- (4) DC 24V for electronic power supply I/O area

Shield attachment

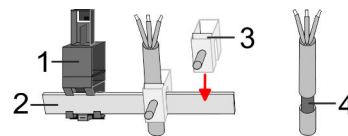

- 1 Shield bus carrier
- 2 Shield bus (10mm x 3mm)
- 3 Shield clamp
- 4 Cable shield

To attach the shield the mounting of shield bus carriers are necessary. The shield bus carrier (available as accessory) serves to carry the shield bus to connect cable shields.

- 1. ➤ Each System SLIO module has a carrier hole for the shield bus carrier. Push the shield bus carrier, until they engage into the module. With a flat mounting rail for adaptation to a flat mounting rail you may remove the spacer of the shield bus carrier.
- 2. ➤ Put your shield bus into the shield bus carrier.

Demounting periphery modules

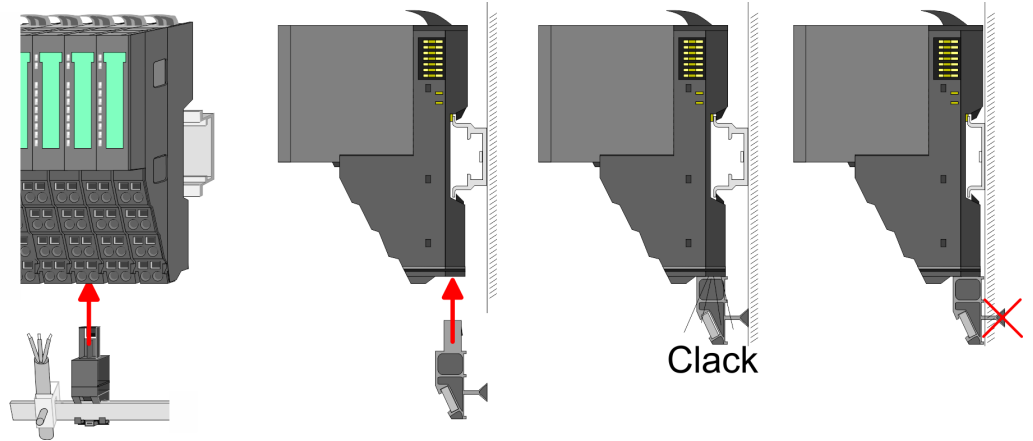

3. Attach the cables with the accordingly stripped cable screen and fix it by the shield clamp with the shield bus.

2.7 Demounting periphery modules

Proceeding

Exchange of an electronic module

1. Power-off your system.

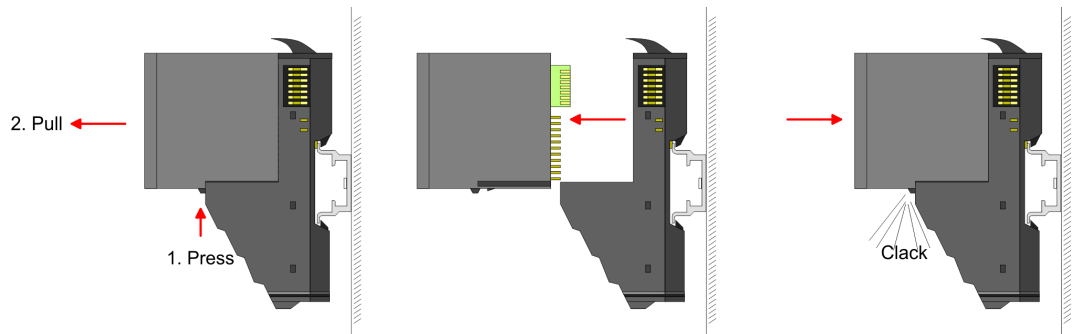

2. For the exchange of a electronic module, the electronic module may be pulled forward after pressing the unlocking lever at the lower side of the module.
3. For installation plug the new electronic module guided by the strips at the lower side until this engages to the terminal module.
⇒ Now you can bring your system back into operation.

Exchange of a periphery module

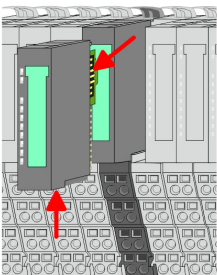

1. Power-off your system.
2. Remove if exists the wiring of the module.
- 3.

i For demounting and exchange of a (head) module or a group of modules, due to mounting reasons you always have to remove the electronic module right beside. After mounting it may be plugged again.

Press the unlocking lever at the lower side of the just mounted right module and pull it forward.

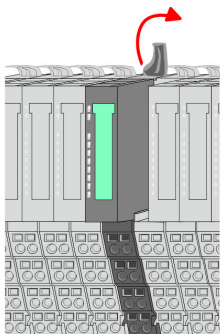

4. Turn the locking lever of the module to be exchanged upwards.

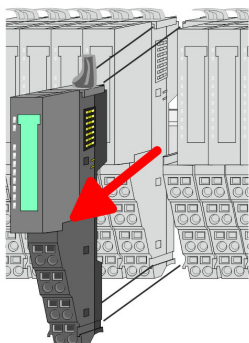

5. Pull the module.
6. For mounting turn the locking lever of the module to be mounted upwards.

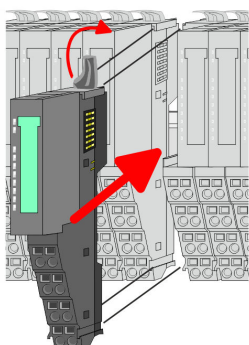

7. To mount the module put it to the gap between the both modules and push it, guided by the stripes at both sides, to the mounting rail.
8. Turn the locking lever downward, again.

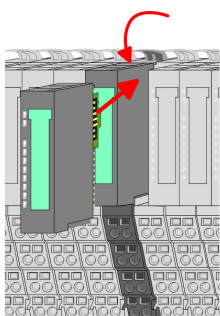

9. Plug again the electronic module, which you have removed before.
10. Wire your module.
 - ⇒ Now you can bring your system back into operation.

Exchange of a module group

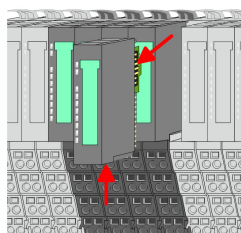

1. Power-off your system.
2. Remove if exists the wiring of the module group.
- 3.

i For demounting and exchange of a (head) module or a group of modules, due to mounting reasons you always have to remove the electronic module right beside. After mounting it may be plugged again.

Press the unlocking lever at the lower side of the just mounted right module near the module group and pull it forward.

Demounting periphery modules

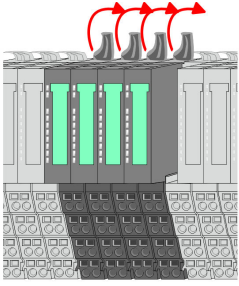

4. Turn all the locking lever of the module group to be exchanged upwards.

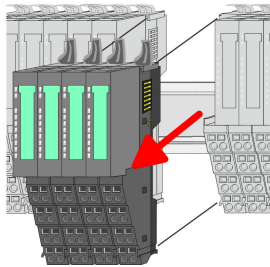

5. Pull the module group forward.

6. For mounting turn all the locking lever of the module group to be mounted upwards.

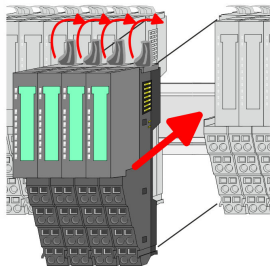

7. To mount the module group put it to the gap between the both modules and push it, guided by the stripes at both sides, to the mounting rail.

8. Turn all the locking lever downward, again.

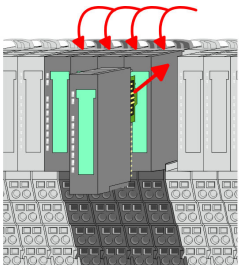

9. Plug again the electronic module, which you have removed before.

10. Wire your module group.

⇒ Now you can bring your system back into operation.

2.7.1 Easy Maintenance

Overview

Easy Maintenance means the support for adding and removing modules during operation without having to restart the system. There are the following behaviors:

- Electronic module is removed
 - The CPU detects a module failure on the backplane bus.
 - Diagnostic message ‘*System SLIO bus failure*’ (0x39D0) is triggered.
 - OB 86 is called. If this is not available, the CPU switches to STOP otherwise it remains in RUN.
 - The SF LED of the CPU lights up.
 - The I/O data of all modules become invalid.
- Identical electronic module is plugged
 - The CPU detects the module return on the backplane bus.
 - The SF-LED of the CPU gets off.
 - All RUN LEDs on the modules get on and the MF LEDs get off.
 - Diagnostic message ‘*System SLIO bus recovery*’ (0x38D0) is triggered.
 - OB 86 is called. If this is not available, the CPU switches to STOP otherwise it remains in RUN.
 - The I/O data of all modules become valid again.
- Wrong electronic module is plugged
 - The CPU detects the wrong module.
 - Diagnostic message ‘*System SLIO bus recovery, but expected configuration does not match actual configuration*’ (0x38D1) is triggered.
 - The SF LED of the CPU remains on.
 - The MF LED of the wrong module flashes.
 - OB 86 is called. If this is not available, the CPU switches to STOP otherwise it remains in RUN.
 - With the exception of the wrong module, the I/O data of all modules become valid again.



Please note that the CPU switches to STOP, if there is no OB 86 configured when adding or removing System SLIO modules!

2.8 Trouble shooting - LEDs

General

Each module has the LEDs RUN and MF on its front side. Errors or incorrect modules may be located by means of these LEDs.

In the following illustrations flashing LEDs are marked by ☼.

Sum current of the electronic power supply exceeded

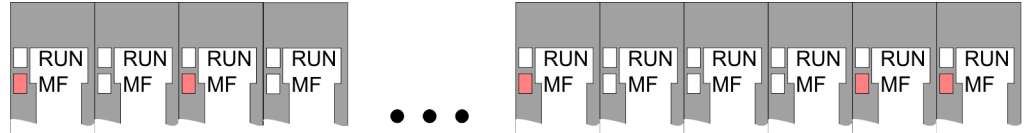

Behaviour: After PowerON the RUN LED of each module is off and the MF LED of each module is sporadically on.

Reason: The maximum current for the electronic power supply is exceeded.

Remedy: As soon as the sum current of the electronic power supply is exceeded, always place the power module 007-1AB10. ↪ Chap. 2.6 'Wiring power modules' page 20

Error in configuration

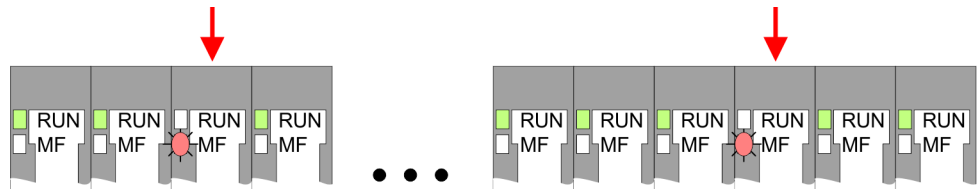

Behaviour: After PowerON the MF LED of one module respectively more modules flashes. The RUN LED remains off.

Reason: At this position a module is placed, which does not correspond to the configured module.

Remedy: Match configuration and hardware structure.

Module failure

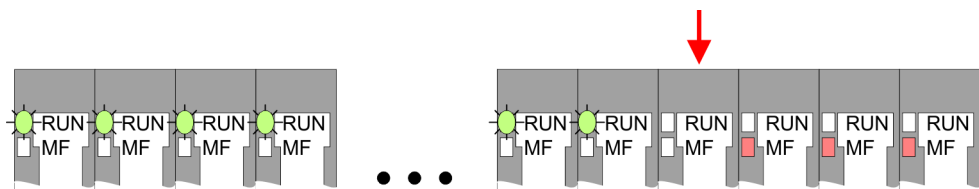

Behaviour: After PowerON all of the RUN LEDs up to the defective module are flashing. With all following modules the MF LED is on and the RUN LED is off.

Reason: The module on the right of the flashing modules is defective.

Remedy: Replace the defective module.

2.9 Installation guidelines

General	<p>The installation guidelines contain information about the interference free deployment of a PLC system. There is the description of the ways, interference may occur in your PLC, how you can make sure the electromagnetic compatibility (EMC), and how you manage the isolation.</p>
What does EMC mean?	<p>Electromagnetic compatibility (EMC) means the ability of an electrical device, to function error free in an electromagnetic environment without being interfered respectively without interfering the environment.</p> <p>The components of VIPA are developed for the deployment in industrial environments and meets high demands on the EMC. Nevertheless you should project an EMC planning before installing the components and take conceivable interference causes into account.</p>
Possible interference causes	<p>Electromagnetic interferences may interfere your control via different ways:</p> <ul style="list-style-type: none">■ Electromagnetic fields (RF coupling)■ Magnetic fields with power frequency■ Bus system■ Power supply■ Protected earth conductor <p>Depending on the spreading medium (lead bound or lead free) and the distance to the interference cause, interferences to your control occur by means of different coupling mechanisms.</p> <p>There are:</p> <ul style="list-style-type: none">■ galvanic coupling■ capacitive coupling■ inductive coupling■ radiant coupling
Basic rules for EMC	<p>In the most times it is enough to take care of some elementary rules to guarantee the EMC. Please regard the following basic rules when installing your PLC.</p> <ul style="list-style-type: none">■ Take care of a correct area-wide grounding of the inactive metal parts when installing your components.<ul style="list-style-type: none">– Install a central connection between the ground and the protected earth conductor system.– Connect all inactive metal extensive and impedance-low.– Please try not to use aluminium parts. Aluminium is easily oxidizing and is therefore less suitable for grounding.■ When cabling, take care of the correct line routing.<ul style="list-style-type: none">– Organize your cabling in line groups (high voltage, current supply, signal and data lines).– Always lay your high voltage lines and signal respectively data lines in separate channels or bundles.– Route the signal and data lines as near as possible beside ground areas (e.g. suspension bars, metal rails, tin cabinet).

- Proof the correct fixing of the lead isolation.
 - Data lines must be laid isolated.
 - Analog lines must be laid isolated. When transmitting signals with small amplitudes the one sided laying of the isolation may be favourable.
 - Lay the line isolation extensively on an isolation/protected earth conductor rail directly after the cabinet entry and fix the isolation with cable clamps.
 - Make sure that the isolation/protected earth conductor rail is connected impedance-low with the cabinet.
 - Use metallic or metallised plug cases for isolated data lines.
- In special use cases you should appoint special EMC actions.
 - Consider to wire all inductivities with erase links.
 - Please consider luminescent lamps can influence signal lines.
- Create a homogeneous reference potential and ground all electrical operating supplies when possible.
 - Please take care for the targeted employment of the grounding actions. The grounding of the PLC serves for protection and functionality activity.
 - Connect installation parts and cabinets with your PLC in star topology with the isolation/protected earth conductor system. So you avoid ground loops.
 - If there are potential differences between installation parts and cabinets, lay sufficiently dimensioned potential compensation lines.

Isolation of conductors

Electrical, magnetically and electromagnetic interference fields are weakened by means of an isolation, one talks of absorption. Via the isolation rail, that is connected conductive with the rack, interference currents are shunt via cable isolation to the ground. Here you have to make sure, that the connection to the protected earth conductor is impedance-low, because otherwise the interference currents may appear as interference cause.

When isolating cables you have to regard the following:

- If possible, use only cables with isolation tangle.
- The hiding power of the isolation should be higher than 80%.
- Normally you should always lay the isolation of cables on both sides. Only by means of the both-sided connection of the isolation you achieve high quality interference suppression in the higher frequency area. Only as exception you may also lay the isolation one-sided. Then you only achieve the absorption of the lower frequencies. A one-sided isolation connection may be convenient, if:
 - the conduction of a potential compensating line is not possible.
 - analog signals (some mV respectively μA) are transferred.
 - foil isolations (static isolations) are used.
- With data lines always use metallic or metallised plugs for serial couplings. Fix the isolation of the data line at the plug rack. Do not lay the isolation on the PIN 1 of the plug bar!
- At stationary operation it is convenient to strip the insulated cable interruption free and lay it on the isolation/protected earth conductor line.
- To fix the isolation tangles use cable clamps out of metal. The clamps must clasp the isolation extensively and have well contact.
- Lay the isolation on an isolation rail directly after the entry of the cable in the cabinet. Lead the isolation further on to your PLC and don't lay it on there again!



CAUTION!

Please regard at installation!

At potential differences between the grounding points, there may be a compensation current via the isolation connected at both sides.

Remedy: Potential compensation line

2.10 General data

Conformity and approval

Conformity		
CE	2014/35/EU	Low-voltage directive
	2014/30/EU	EMC directive
Approval		
UL	-	Refer to Technical data
others		
RoHS	2011/65/EU	Restriction of the use of certain hazardous substances in electrical and electronic equipment

Protection of persons and device protection

Type of protection	-	IP20
Electrical isolation		
to the field bus	-	electrically isolated
to the process level	-	electrically isolated
Insulation resistance	-	-
Insulation voltage to reference earth		
Inputs / outputs	-	AC / DC 50V, test voltage AC 500V
Protective measures	-	against short circuit

Environmental conditions to EN 61131-2

Climatic		
Storage / transport	EN 60068-2-14	-25...+70°C
Operation		
Horizontal installation hanging	EN 61131-2	0...+60°C
Horizontal installation lying	EN 61131-2	0...+55°C
Vertical installation	EN 61131-2	0...+50°C
Air humidity	EN 60068-2-30	RH1 (without condensation, rel. humidity 10...95%)
Pollution	EN 61131-2	Degree of pollution 2
Installation altitude max.	-	2000m
Mechanical		
Oscillation	EN 60068-2-6	1g, 9Hz ... 150Hz
Shock	EN 60068-2-27	15g, 11ms

General data

Mounting conditions		
Mounting place	-	In the control cabinet
Mounting position	-	Horizontal and vertical

EMC	Standard	Comment	
Emitted interference	EN 61000-6-4	Class A (Industrial area)	
Noise immunity zone B	EN 61000-6-2	Industrial area	
		EN 61000-4-2	ESD 8kV at air discharge (degree of severity 3), 4kV at contact discharge (degree of severity 2)
		EN 61000-4-3	HF field immunity (casing) 80MHz ... 1000MHz, 10V/m, 80% AM (1kHz) 1.4GHz ... 2.0GHz, 3V/m, 80% AM (1kHz) 2GHz ... 2.7GHz, 1V/m, 80% AM (1kHz)
		EN 61000-4-6	HF conducted 150kHz ... 80MHz, 10V, 80% AM (1kHz)
		EN 61000-4-4	Burst, degree of severity 3
	EN 61000-4-5	Surge, degree of severity 3 *	

*) Due to the high-energetic single pulses with Surge an appropriate external protective circuit with lightning protection elements like conductors for lightning and overvoltage is necessary.

3 Hardware description

3.1 Properties

Features

- 1 counter 32bit (AB) invertible, DC 5V (difference signal)
- Counting frequency max. 2MHz
(AB 1/2/4-fold evaluation or pulse and direction)
- Comparison value, set value, input filter, reset
- Interrupt and diagnostics function with μ s time stamp
- μ s time stamp for counter value (e.g. for speed calculation)

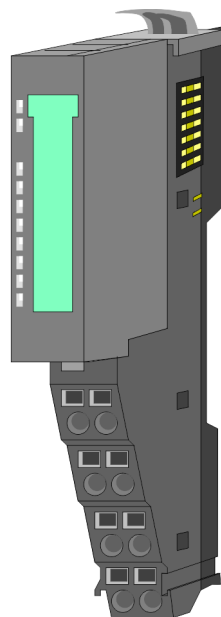

Order data

Type	Order number	Beschreibung
FM 050	050-1BA10	Counter module 5V differential 1x32Bit

3.2 Structure

050-1BA10

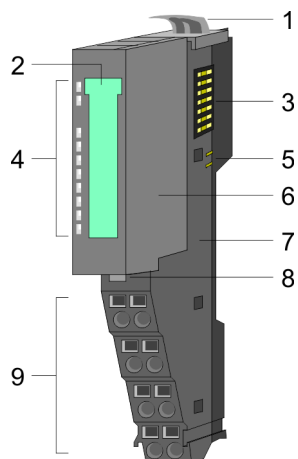

- 1 Locking lever terminal module
- 2 Labeling strip
- 3 Backplane bus
- 4 LED status indication
- 5 DC 24V power section supply
- 6 Electronic module
- 7 Terminal module
- 8 Locking lever electronic module
- 9 Terminal

Status indication

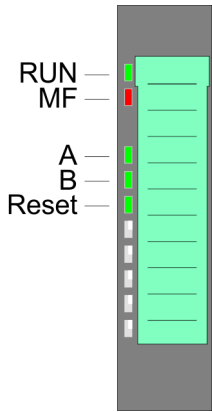

LED		Description
RUN green ■	MF red ■	
●	○	Bus communication is OK Module status is OK
●	●	Bus communication is OK Module status reports an error
○	●	Bus communication is not possible Module status reports an error
○	○	Error at bus power supply
X	B	Error in configuration (see Basics) ↗ <i>Chap. 2.8 'Trouble shooting - LEDs' page 28</i>
A	green ■	● Inputs 1, 5 A/pulse are set
B	green ■	● Inputs 4, 8 B/direction are set
Reset	green ■	● Inputs 6, 7 Resets are set
on: ● off: ○ blinks with 2Hz: B not relevant: X		

Pin assignment

For wires with a cross section of 0.08mm² up to 1.5mm².

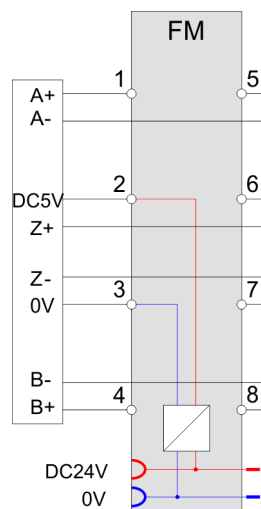
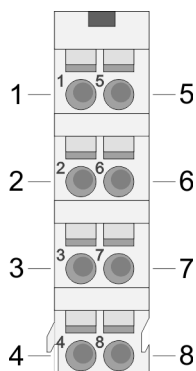

Pos.	Function	Type	Description
1	A+	I	A / pulse Difference input for counter signal res. track A of an encoder for 1-, 2- or 4-fold evaluation
2	DC 5V	O	DC 5V for encoder (max. 500mA)
3	0V	O	GND
4	B+	I	B / direction Difference input for direction signal res. track B of an encoder (invertible via parameterization)
5	A-	I	A / pulse Difference input for counter signal res. track A of an encoder for 1-, 2- or 4-fold evaluation
6	Z+	I	Difference input for Reset
7	Z-	I	Difference input for Reset
8	B-	I	B / direction Difference input for direction signal res. track B of an encoder (invertible via parameterization)

I: Input, O: Output

3.3 Technical data

Order no.	050-1BA10
Type	FM 050
Module ID	08C2 3801
Current consumption/power loss	
Current consumption from backplane bus	75 mA
Power loss	0.85 W
Technical data digital inputs	
Number of inputs	-
Cable length, shielded	100 m
Cable length, unshielded	-
Rated load voltage	DC 20.4...28.8 V
Reverse polarity protection of rated load voltage	-
Current consumption from load voltage L+ (without load)	20 mA
Rated value	-
Input voltage for signal "0"	Differential signal RS422
Input voltage for signal "1"	Differential signal RS422
Input voltage hysteresis	-
Signal logic input	-
Frequency range	-
Input resistance	120 Ω
Input current for signal "1"	-
Connection of Two-Wire-BEROs possible	-
Max. permissible BERO quiescent current	-
Input delay of "0" to "1"	0.8 μs
Input delay of "1" to "0"	0.8 μs
Number of simultaneously utilizable inputs horizontal configuration	-
Number of simultaneously utilizable inputs vertical configuration	-
Input characteristic curve	-
Initial data size	8 Byte
Technical data digital outputs	
Number of outputs	-
Cable length, shielded	-
Cable length, unshielded	-
Rated load voltage	-
Current consumption from load voltage L+ (without load)	-

Order no.	050-1BA10
Output delay of "0" to "1"	-
Output delay of "1" to "0"	-
Minimum load current	-
Lamp load	-
Parallel switching of outputs for redundant control of a load	-
Parallel switching of outputs for increased power	-
Actuation of digital input	-
Switching frequency with resistive load	-
Switching frequency with inductive load	-
Switching frequency on lamp load	-
Internal limitation of inductive shut-off voltage	-
Short-circuit protection of output	-
Trigger level	-
Number of operating cycle of relay outputs	-
Switching capacity of contacts	-
Output data size	10 Byte
Technical data counters	
Number of counters	1
Counter width	32 Bit
Maximum input frequency	500 kHz
Maximum count frequency	2 MHz
Mode incremental encoder	✓
Mode pulse / direction	✓
Mode pulse	-
Mode frequency counter	-
Mode period measurement	-
Gate input available	-
Latch input available	-
Reset input available	✓
Counter output available	-
Status information, alarms, diagnostics	
Status display	yes
Interrupts	yes, parameterizable
Process alarm	yes, parameterizable
Diagnostic interrupt	yes, parameterizable
Diagnostic functions	yes, parameterizable

Technical data

Order no.	050-1BA10
Diagnostics information read-out	possible
Module state	green LED
Module error display	red LED
Channel error display	none
Isolation	
Between channels	-
Between channels of groups to	-
Between channels and backplane bus	✓
Between channels and power supply	-
Max. potential difference between circuits	-
Max. potential difference between inputs (Ucm)	-
Max. potential difference between Mana and Mintern (Uiso)	-
Max. potential difference between inputs and Mana (Ucm)	-
Max. potential difference between inputs and Mintern (Uiso)	-
Max. potential difference between Mintern and outputs	-
Insulation tested with	DC 500 V
Datasizes	
Input bytes	8
Output bytes	10
Parameter bytes	23
Diagnostic bytes	20
Housing	
Material	PPE / PPE GF10
Mounting	Profile rail 35 mm
Mechanical data	
Dimensions (WxHxD)	12.9 mm x 109 mm x 76.5 mm
Net weight	58 g
Weight including accessories	58 g
Gross weight	72 g
Environmental conditions	
Operating temperature	0 °C to 60 °C
Storage temperature	-25 °C to 70 °C
Certifications	
UL certification	yes
KC certification	yes

4 Deployment

4.1 Fast introduction

Counter range

Limits	Valid range of values
Lower counter limit	-2 147 483 648 (-2^{31})
Upper counter limit	+2 147 483 647 ($2^{31}-1$)

The maximum counter frequency is 2MHz.

Address area

Input area

At CPU, PROFIBUS and PROFINET the input area is embedded to the corresponding address area.

IX - Index for access via CANopen

SX - Subindex for access via EtherCAT with Index 6000h + EtherCAT-Slot

More can be found in the according manual of your bus coupler.

Addr.	Name	Bytes	Function	IX	SX
+0	CV_I	4	Counter value	5400h	01h
+4	CSTS_I	2	Counter status	5402h	02h
+6	C_US	2	16bit μ s value	5403h	03h

Output area

At CPU, PROFIBUS and PROFINET the output area is embedded to the corresponding address area.

IX - Index for access via CANopen

SX - Subindex for access via EtherCAT with Index 7000h + EtherCAT-Slot

More can be found in the according manual of your bus coupler.

Addr.	Name	Bytes	Function	IX	SX
+0	CC_I	4	Comparison value	5600h	01h
+4	CS_I	4	Set value	5601h	02h
+8	CCTRL_I	2	Control word	5602h	03h

CSTS_I Counter status

Bit	Name	Function
0	STS_SYNC	Reset was active
1	STS_CTRL_COMP	is set when <i>comparison</i> bit is enabled
2	STS_SW-GATE	Status software gate (set when <i>SW gate</i> is active)
3	STS_RST	Status reset input

Fast introduction

Bit	Name	Function
4	-	reserved
5	STS_GATE	Status internal gate (set when internal gate active)
6	STS_COMP	Status <i>comparison</i> bit
7	STS_C_DN	Status set at counter direction backward
8	STS_C_UP	Status set at counter direction forward
9	STS_CMP*	Status comparison is set when the comparison condition is met. If comparison is parameterized <i>never</i> , the bit is never set
10	STS_END*	Status is set when <i>end value</i> was reached
11	STS_OFLW*	Status is set at overflow
12	STS_UFLW*	Status is set at underflow
13	STS_ZP*	Status is set at zero run
14 ... 15	-	reserved

*) The bits remain set until reset with RES_SET (bit 6 *control word*).

CCTRL_I Control word

Bit	Name	Function
0	CTRL_SYNC_SET	activates the reset mode
1	CTRL_COMP_SET	enables the <i>comparison</i> bit
2	SW_GATE_SET	sets the software gate
3	-	reserved
4	-	reserved
5	COUNTERVAL_SET	sets counter temporarily to the value of <i>set value</i>
6	RES_SET	resets the bits STS_CMP, STS_END, STS_OFLW, STS_UFLW and STS_ZP with edge 0-1
7	-	reserved
8	CTRL_SYNC_RESET	deactivates the reset mode
9	CTRL_COMP_RESET	disables the <i>comparison bit</i>
10	SW_GATE_RESET	resets the software gate
11 ... 15	-	reserved

Parameters

DS - Record set for access via CPU, PROFIBUS and PROFINET

IX - Index for access via CANopen

SX - Subindex for access via EtherCAT with Index 3100h + EtherCAT-Slot

More can be found in the according manual of your bus coupler.

Name	Bytes	Function	Default	DS	IX	SX
DIAG_EN	1	Diagnostic interrupt*	00h	00h	3100h	01h
CH0A	1	Input frequency track A	02h	01h	3101h	02h
CH1B	1	Input frequency track B	02h	01h	3102h	03h
CH2R	1	Input frequency Reset	02h	01h	3103h	04h
CH3	1	reserved	00h	01h	3104h	05h
INT_I	1	Interrupt behavior*	00h	80h	3105h	06h
FCT_I	1	Counter function*	00h	80h	3106h	07h
MODE2_I	1	Counter mode 2*	00h	80h	3107h	08h
MODE3_I	1	Counter mode 3*	00h	80h	3108h	09h
END_I	4	End value	00h	81h	3109h...310Ch	0Ah
LOAD_I	4	Load value	00h	81h	310Dh...3110h	0Bh
HYST_I	1	Hysteresis	00h	81h	3111h	0Ch
CRES	1	reserved	00h	81h	3112h	0Dh

*) This parameter may only be transferred at STOP state.

Control counter

The counter is controlled via the internal gate (I gate). The I gate corresponds to the software gate (SW gate).

SW gate:

Open (activate):

in user program by edge 0-1 of SW_GATE_SET in the *control word*.

Close (deactivate):

in user program by edge 0-1 of SW_GATE_RESET in the *control word*.

Comparison bit

The following behavior for the *comparison bit* STS_COMP in the *counter status* may be set via the parameterization:

- No comparison: Comparison bit is not influenced
- *Counter value* \geq *comparison value*: *Comparison bit* is set
- *Counter value* \leq *comparison value*: *Comparison bit* is set
- *Counter value* = *comparison value*: *Comparison bit* is set

Please consider that the *comparison bit* may only be set, when the bit STS_CTRL_COMP in the *counter status* is set.

4.2 In-/Output area

4.2.1 Input area 8byte

Input area

At CPU, PROFIBUS and PROFINET the input area is embedded to the corresponding address area.

IX - Index for access via CANopen

SX - Subindex for access via EtherCAT with Index 6000h + EtherCAT-Slot

In-/Output area > Input area 8byte

More can be found in the according manual of your bus coupler.

8byte	Addr.	Name	Bytes	Function	IX	SX
	+0	CV_I	4	Counter value	5400h	01h
	+4	CSTS_I	2	Counter status	5402h	02h
	+6	C_US	2	16bit μ s value	5403h	03h

CV_I Counter value The *counter value* always contains the current value of the counter.

CSTS_I Counter status

Bit	Name	Function
0	STS_SYNC	Reset was active
1	STS_CTRL_COMP	is set when <i>comparison bit</i> is enabled
2	STS_SW-GATE	Status software gate (set when <i>SW gate</i> is active)
3	STS_RST	Status reset input
4	-	reserved
5	STS_GATE	Status internal gate (set when internal gate active)
6	STS_COMP	Status <i>comparison bit</i>
7	STS_C_DN	Status set at counter direction backward
8	STS_C_UP	Status set at counter direction forward
9	STS_CMP*	Status comparison is set when the comparison condition is met. If comparison is parameterized <i>never</i> , the bit is never set
10	STS_END*	Status is set when <i>end value</i> was reached
11	STS_OFLW*	Status is set at overflow
12	STS_UFLW*	Status is set at underflow
13	STS_ZP*	Status is set at zero run
14 ... 15	-	reserved

*) The bits remain set until reset with RES_SET (bit 6 control word).

C_US 16bit μ s value In the SLIO module there is a timer (μ s ticker). With PowerON the timer starts counting with 0. After 65535 μ s the timer starts with 0 again. With each change of the *counter value* the timer value is stored as 16bit μ s value together with the *counter value* in the *input area*.

4.2.2 Output area 10byte

Output area

At CPU, PROFIBUS and PROFINET the output area is embedded to the corresponding address area.

IX - Index for access via CANopen

SX - Subindex for access via EtherCAT with Index 7000h + EtherCAT-Slot

More can be found in the according manual of your bus coupler.

10byte

Addr.	Name	Bytes	Function	IX	SX
+0	CC_I	4	Comparison value	5600h	01h
+4	CS_I	4	Set value	5601h	02h
+8	CCTRL_I	2	Control word	5602h	03h

CC_I Comparison value

With *comparison value* a value may be preset that may influence the *comparison bit* res. throw a process interrupt when compared with the recent *counter value*. The behavior of the *comparison bit* respectively the process interrupt may be set via the parameter MODE2_I respectively INIT_I.

CS_I Set value

By means of the *set value* there is the possibility to preset the counter with the *set value*. The value is kept by the counter by an changing edge 0-1 of the bit COUNTERVAL_SET in the *control word*.

CCTRL_I Control word

Bit	Name	Function
0	CTRL_SYNC_SET	activates the reset mode
1	CTRL_COMP_SET	enables the <i>comparison bit</i>
2	SW_GATE_SET	sets the software gate
3 ... 4	-	reserved
5	COUNTERVAL_SET	sets counter temporarily to the value of <i>set value</i>
6	RES_SET	resets the bits STS_CMP, STS_END, STS_OFLW, STS_UFLW and STS_ZP with rising edge
7	-	reserved
8	CTRL_SYNC_RESET	deactivates the reset mode
9	CTRL_COMP_RESET	disables the <i>comparison bit</i>
10	SW_GATE_RESET	resets the software gate
11 ... 15	-	reserved

4.3 Parameter data

Via parameterization you may define among others:

- Interrupt behavior
- Input filter
- Counter operating mode res. behavior
- *Load value and end value*

DS - Record set for access via CPU, PROFIBUS and PROFINET

IX - Index for access via CANopen

SX - Subindex for access via EtherCAT with Index 3100h + EtherCAT-Slot

More can be found in the according manual of your bus coupler.

Parameters

Name	Bytes	Function	Default	DS	IX	SX
DIAG_EN	1	Diagnostic interrupt*	00h	00h	3100h	01h
CH0A	1	Input frequency track A	02h	01h	3101h	02h
CH1B	1	Input frequency track B	02h	01h	3102h	03h
CH2R	1	Input frequency Reset	02h	01h	3103h	04h
CH3	1	reserved	00h	01h	3104h	05h
INT_I	1	Interrupt behavior*	00h	80h	3105h	06h
FCT_I	1	Counter function*	00h	80h	3106h	07h
MODE2_I	1	Counter mode 2*	00h	80h	3107h	08h
MODE3_I	1	Counter mode 3*	00h	80h	3108h	09h
END_I	4	End value	00h	81h	3109h...310Ch	0Ah
LOAD_I	4	Load value	00h	81h	310Dh...3110h	0Bh
HYST_I	1	Hysteresis	00h	81h	3111h	0Ch
CRES	1	reserved	00h	81h	3112h	0Dh

*) This parameter may only be transferred at STOP state.

DIAG_EN Diagnostic interrupt

Byte	Bit 7 ... 0
0	Diagnostic interrupt <ul style="list-style-type: none"> ■ 00h = disable ■ 40h = enable

- Here you activate res. de-activate the diagnostic function.

CHxx Input frequency

Byte	Function	Possible values
0	Input frequency track A	<ul style="list-style-type: none"> ■ 00h: 500kHz ■ 01h: 300kHz ■ 02h: 100kHz ■ 03h: 60kHz ■ 04h: 30kHz
1	Input frequency track B	<ul style="list-style-type: none"> ■ 06h: 10kHz ■ 07h: 5kHz ■ 08h: 2kHz ■ 09h: 1kHz <p>Other values are not permissible!</p>
2	Input frequency Reset	02h: 100kHz (fix)
3	reserved	

- *Input frequency* allows you to preset a filter for input track A and track B. With the help of filters you may e.g. filter signal peaks at a blurred input signal.

INT_I Interrupt behavior

Byte	Bit 7 ... 0
0	<ul style="list-style-type: none"> ■ <i>Bit 5 ... 0: Interrupt behavior</i> ■ Bit 0: 0 (fix) ■ Bit 1: 0 (fix) ■ Bit 2: Proc. interrupt overflow ■ Bit 3: Proc. interrupt underflow ■ Bit 4: Proc. interrupt <i>comparison value</i> ■ Bit 5: Proc. interrupt <i>end value</i> ■ <i>Bit 7 ... 6: 0 (fix)</i>

- Setting the appropriate bit activates the associated process interrupt.

FCT_I Counter function

Byte	Bit 7 ... 0
0	<ul style="list-style-type: none"> ■ <i>Bit 5 ... 0: Counter function</i> <ul style="list-style-type: none"> – 000000b = Count endless – 000001b = Once: forward – 000010b = Once: backwards – 000100b = Once: no main direction – 001000b = Periodic: forward – 010000b = Periodic: backwards – 100000b = Periodic: no main direction ■ <i>Bit 7 ... 6: 0 (fix)</i>

MODE2_I Counter mode 2

Byte	Bit 7 ... 0
0	<ul style="list-style-type: none"> ■ <i>Bit 2 ... 0: Comparison bit is set</i> (... when following condition is met) <ul style="list-style-type: none"> – 000b = never – 001b = <i>counter value</i> ≥ <i>comparison value</i> – 010b = <i>counter value</i> ≤ <i>comparison value</i> – 100b = <i>counter value</i> = <i>comparison value</i> ■ <i>Bit 3: Count direction track B inverted</i> <ul style="list-style-type: none"> – 0 = No (not inverted) – 1 = Yes (inverted) ■ <i>Bit 6 ... 4: Reset</i> <ul style="list-style-type: none"> – 000b = de-activated – 001b = high level – 011b = edge 0-1 – 101b = edge 0-1 once ■ <i>Bit 7: 0 (fix)</i>

- For activation of the comparison bit STS_COMP the bit CTRL_COMP_SET (bit 1) of the *control word* must be set!
- For activation of reset the bit CTRL_SYNC_SET (bit 0) of the *control word* must be set!

MODE3_I Counter mode 3

Byte	Bit 7 ... 0
0	<ul style="list-style-type: none"> ■ <i>Bit 2 ... 0: Signal evaluation</i> <ul style="list-style-type: none"> – 000b = Counter de-activated – 001b = Rotary encoder single (at A and B) – 010b = Rotary encoder double (at A and B) – 011b = Rotary encoder quadruple (at A and B) – 100b = Direction (pulse at A and direction at B) ■ <i>Bit 6 ... 3: 0 (fix)</i> ■ <i>Bit 7: Gate function (internal gate)</i> <ul style="list-style-type: none"> – 0 = abort – 1 = interrupt

- At de-activated counter the further parameter settings are ignored.
- With gate function "abort" counting begins again at the load value. With "interrupt" counting is continued with the count.

END_I End value, LOAD_I Load value

You may set an upper and a lower limit by setting a *load value* as start and an *end value*.

HYST_I Hysteresis

The *hysteresis* serves the avoidance of many toggle processes of the *comparison bit* and the interrupt, if the *counter value* is in the range of the *comparison value*. You may set a range of 0 to 255. The settings 0 and 1 deactivate the *hysteresis*. The *hysteresis* influences zero run, comparison, over- and underflow.

4.4 Counter - Functions

Overview

You may count forward and backwards and choose between the following counter functions:

- Count endless, e.g. distance measuring with incremental encoder
- Count once, e.g. count to a maximum limit
- Count periodic, e.g. count with repeated counter process

In the operating modes "Count once" and "Count periodic" you may define a counter range as start and end value via the parameterization. For every counter additional parameterizable functions are available like gate function, comparison, hysteresis and process interrupt.

Main counting direction

Via the parameterization you have the opportunity to define a main counting direction for every counter. If "none" is chosen, the complete counting range is available:

Limits	Valid value range
Lower count limit	-2 147 483 648 (-2^{31})
Upper count limit	+2 147 483 647 ($2^{31}-1$)

Main counting direction forward

Upper restriction of the count range. The counter counts 0 res. *load value* in positive direction until the parameterized *end value* -1 and jumps then back to the load value with the next following encoder pulse.

Main counting direction backwards

Lower restriction of the count range. The counter counts from the parameterized start-res. *load value* in negative direction to the parameterized *end value* +1 and jumps then back to the start value with the next following encoder pulse.

Gate function abort/interrupt

An opening and closing of the SW gate abort or interrupts the count process.

Abort count process

The count process starts after closing and restart of the gate beginning with the *load value*.

Interrupt count process

The count process continuous after closing and restart of the gate beginning with the last recent counter value.

Count continuously

In this operating mode, the counter counts from the load value. When the counter counts forward and reaches the upper count limit and another counting pulse in positive direction arrives, it jumps to the lower count limit and counts from there on. When the counter counts backwards and reaches the lower count limit and another counting pulse in negative direction arrives, it jumps to the upper count limit and counts from there on. The count limits are set to the maximum count range.

Limits	Valid value range
Lower count limit	-2 147 483 648 (-2^{31})
Upper count limit	+2 147 483 647 ($2^{31}-1$)

With overflow or underflow the status bits STS_OFLW respectively STS_UFLW are set. These bits remain set until these are reset with RES_STS. If enabled additionally a process interrupt is triggered.

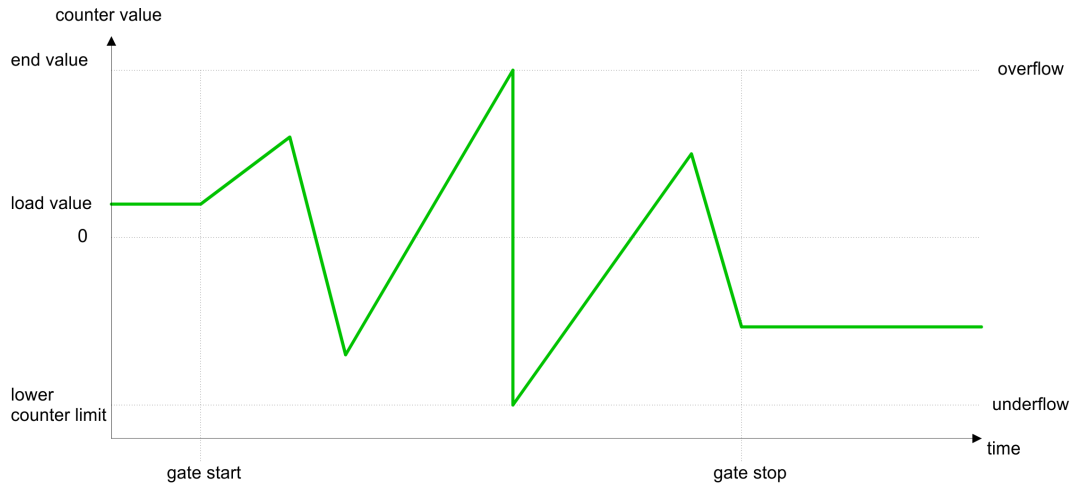

Count Once

No main counting direction

- The counter counts once starting with the *load value*.
- You may count forward or backwards.
- The count limits are set to the maximum count range.
- At over- or underflow at the count limits, the counter jumps to the according other count limit and the internal gate is automatically closed and the status bits STS_OFLW respectively STS_UFLW are set. If enabled additionally a process interrupt is triggered.
- To restart the count process, you have to re-open the internal gate.
- At interrupting gate control, the count process continuous with the last recent *counter value*.
- At aborting gate control, the counter starts with the *load value*.

Limits	Valid value range
Lower count limit	-2 147 483 648 (-2^{31})
Upper count limit	+2 147 483 647 ($2^{31} - 1$)

Interrupting gate control:



Aborting gate control:



Main counting direction forward

- The counter counts starting with the *load value*.
- When the counter reaches the end value -1 in positive direction, it jumps to the load value at the next positive count pulse and the gate is automatically closed.
- To restart the count process, you must create a positive edge of the gate. The counter starts with the load value.

Limits	Valid value range
Limit value	-2 147 483 647 ($-2^{31} + 1$) to +2 147 483 647 ($2^{31} - 1$)
Lower count limit	-2 147 483 648 (-2^{31})

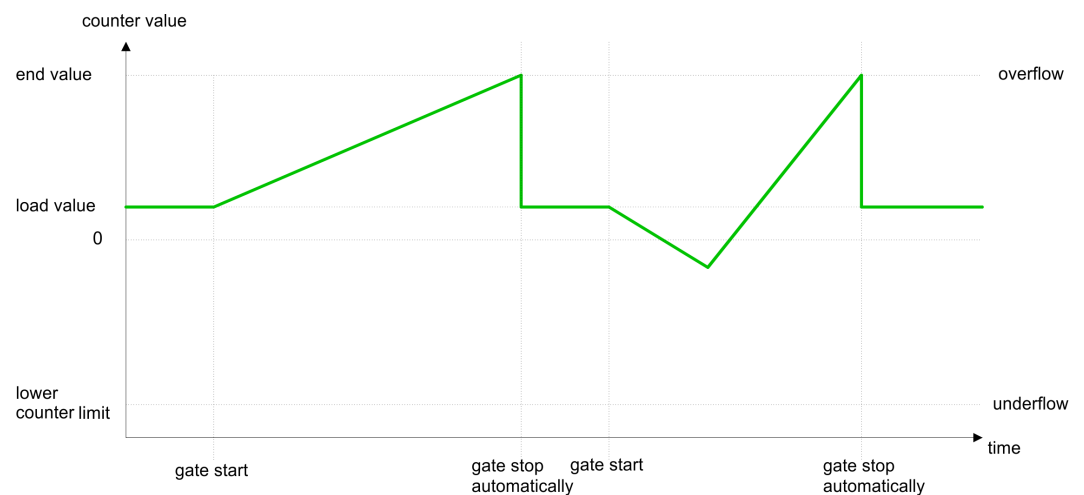

Main counting direction backwards

- The counter counts backwards starting with the *load value*.
- When the counter reaches the end value +1 in negative direction, it jumps to the load value at the next negative count pulse and the gate is automatically closed.
- To restart the count process, you must create a positive edge of the gate. The counter starts with the load value.

Limits	Valid value range
Limit value	-2 147 483 648 (-2^{31}) to +2 147 483 646 ($2^{31} - 2$)
Upper count limit	+2 147 483 647 ($2^{31} - 1$)



Count Periodically

No main counting direction

- The counter counts forward or backwards starting with the *load value*.
- At over- or underrun at the count limits, the counter jumps to the according other count limit and counts from there on.
- The count limits are set to the maximum count range.

Limits	Valid value range
Lower count limit	-2 147 483 648 (-2^{31})
Upper count limit	+2 147 483 647 ($2^{31} - 1$)



Main counting direction forward

- The counter counts forward starting with the *load value*.
- When the counter reaches the end value -1 in positive direction, it jumps to the load value at the next positive count pulse.

Limits	Valid value range
Limit value	-2 147 483 647 ($-2^{31} + 1$) to +2 147 483 647 ($2^{31} - 1$)
Lower count limit	-2 147 483 648 (-2^{31})

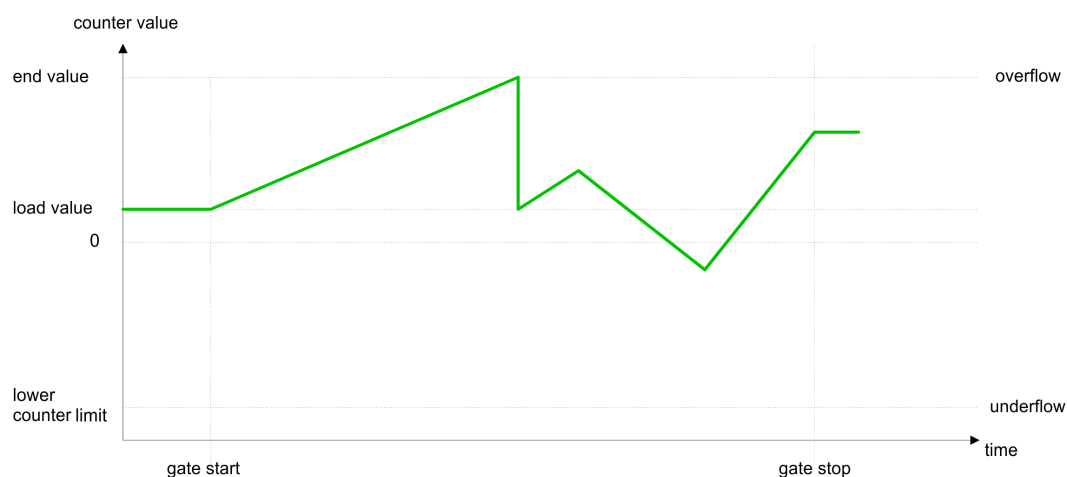

Main counting direction backwards

- The counter counts backwards starting with the *load value*.
- When the counter reaches the *end value* +1 in negative direction, it jumps to the *load value* at the next negative count pulse.
- You may exceed the upper count limit.

Limits	Valid value range
Limit value	-2 147 483 648 (-2^{31}) to +2 147 483 646 ($2^{31} - 2$)
Upper count limit	+2 147 483 647 ($2^{31} - 1$)



4.5 Counter additional functions

Overview

The following additional functions may be set for each counter via the parameterization:

- Gate function
 - The gate function serves for the start, stop and interrupt of a count function.
- Comparison
 - You may set a *comparison value* that activates res. de-activates the digital output res. releases a process interrupt depending on the *counter value*.
- Hysteresis
 - The setting of a *hysteresis* avoids for example a high interrupt toggling when the value of an encoder signal shifts around a comparison value.

Schematic structure

The illustration shows how the additional functions influence the counting behavior. The following pages describe these functions in detail:

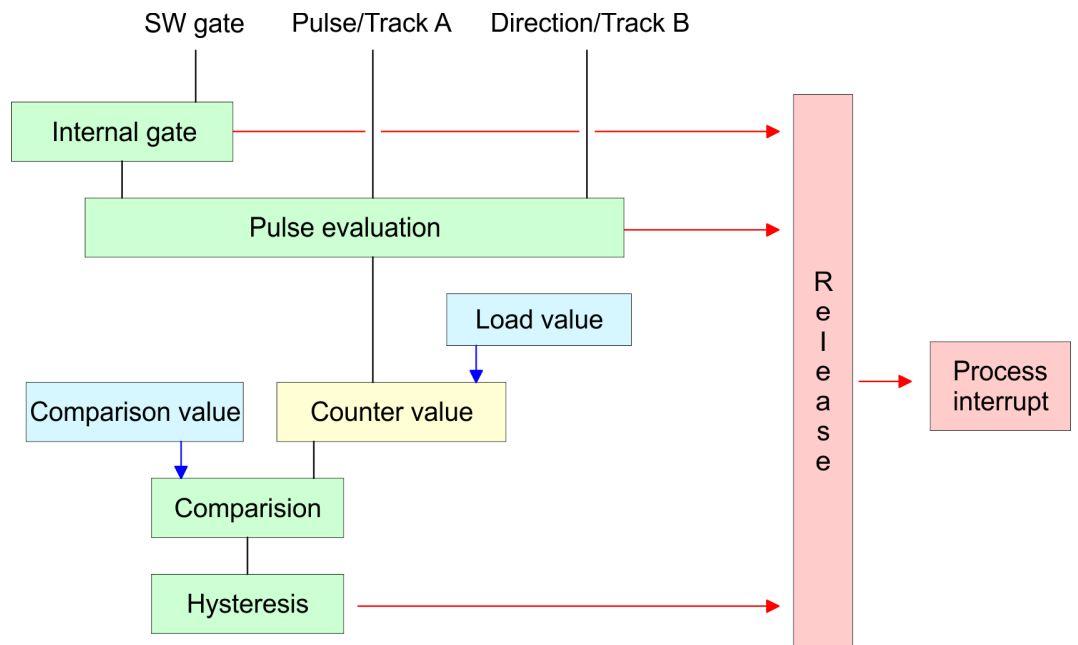

Gate function

The activation res. de-activation of the counter happens via an internal gate (I gate). The I gate corresponds to the software gate (SW gate). The *SW gate* is opened (activated) via your user application by an edge 0-1 of the bit *SW_GATE_SET* of the *control word* in the output area. The software gate is closed (de-activated) by an edge 0-1 of the bit *SW_GATE_RESET*. If the I gate was automatically closed at "counting once", so this may only be opened with an edge 0-1 on *SW_GATE_SET*. The following states influence the I gate:

SW gate	influences I gate
0	0
1	1
with edge 0-1	1

Gate function abort and interrupt

The parameterization defines if the gate interrupts or aborts the counter process.

- At *abort function* the counter starts counting with the *load value* after gate restart.

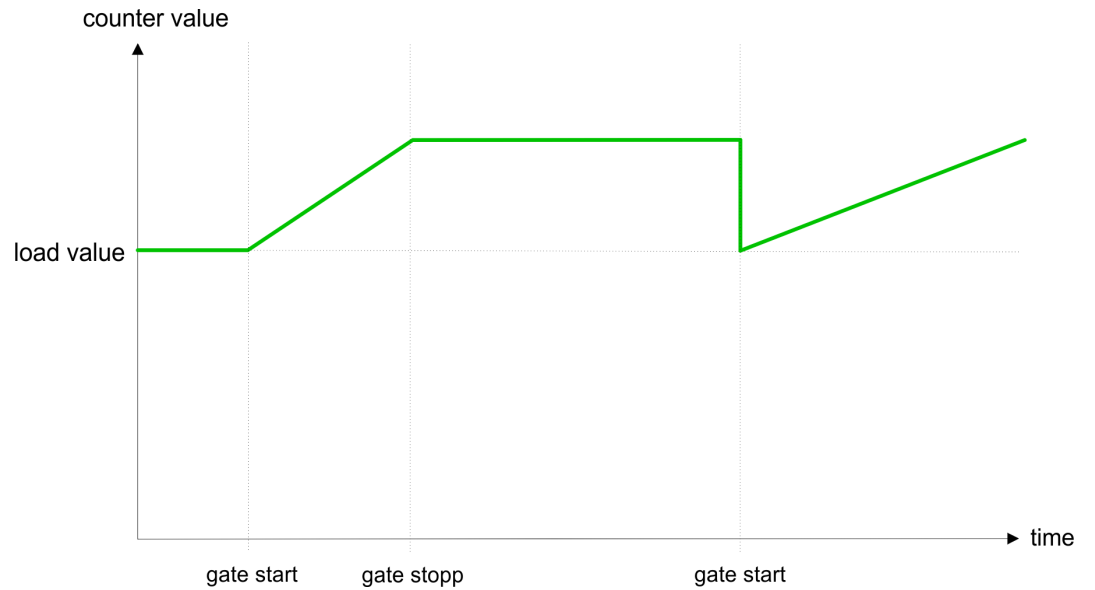

- At *interrupt function*, the counter starts counting with the recent *counter value* after gate restart.



Comparison function

The *compare value* is to be pre-defined by the *output area*. The *comparison bit* may be found at the *counter status* at STS_COMP. Please consider that the bit STS_COMP may only be influenced when in the counter status the bit STS_CTRL_COMP is set. The following behavior for the *comparison bit* may be pre-defined via the parameterization:

- no comparison: *Comparison bit* is not influenced
- $Counter\ value \geq compare\ value$: *Comparison bit* is set
- $Counter\ value \leq compare\ value$: *Comparison bit* is set
- $Counter\ value = compare\ value$: *Comparison bit* is set

no comparison

The *comparison bit* is not influenced.

Comparison bit is set when counter value \geq comparison value

The *comparison bit* remains set as long as the *counter value* is higher or equal *comparison value*.

Comparison bit is set when counter value \leq comparison value

The *comparison bit* remains set as long as the *counter value* is lower or equal *comparison value*.

Comparison bit is set when counter value = comparison value

When the counter reaches the *comparison value* the *comparison bit* is set. The *comparison bit* remains set as long as the comparison condition is met. When you've set a main counting direction the *comparison bit* is only set at reaching the *comparison value* from the main counting direction.



The bit *STS_COMP* is set together with the bit *STS_CMP* in the counter status. In contrast to the bit *STS_COMP* this bit remains set as long as it is reset by setting the bit *RES_SET* in the control word.

Hysteresis

The *hysteresis* serves e.g. the avoidance of many toggle processes of the interrupt, if the counter value is in the range of the *comparison value*. You may set a range of 0 to 255. The settings 0 and 1 deactivate the hysteresis. The *hysteresis* influences the zero run, over-/underflow and *comparison value*. An activated *hysteresis* remains active after a change. The new *hysteresis* range is taken over at the next *hysteresis* event. The following pictures illustrate the behavior of the *comparison bit* for *hysteresis* 0 and *hysteresis* 3 for the according conditions:

Effect at counter value \geq comparison value

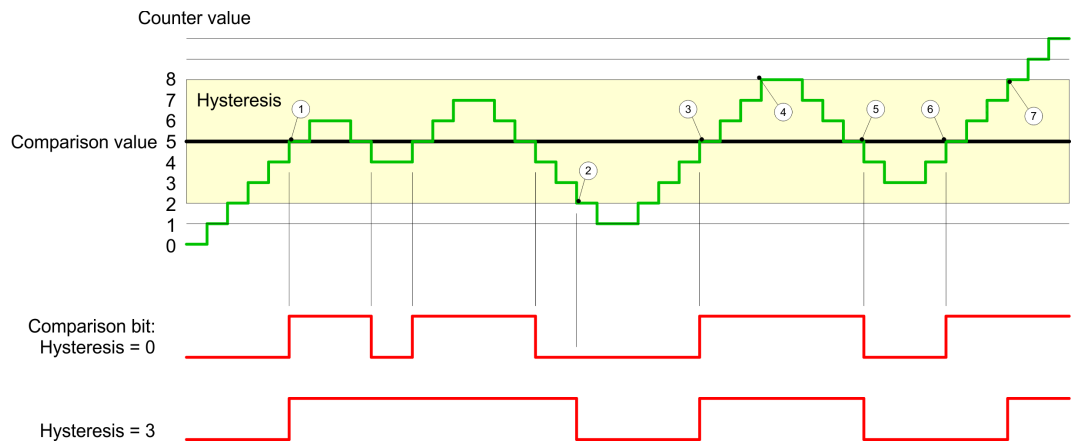

- 1 Counter value \geq comparison value \rightarrow comparison bit is set and hysteresis activated
- 2 Leave hysteresis range \rightarrow comparison bit is reset
- 3 Counter value \geq comparison value \rightarrow comparison bit is set and hysteresis activated
- 4 Leave hysteresis range, comparison bit remains set for counter value \geq comparison value
- 5 Counter value $<$ comparison value and hysteresis active \rightarrow comparison bit is reset
- 6 Counter value \geq comparison value \rightarrow comparison bit is not set for hysteresis active
- 7 Leave hysteresis range, comparison bit remains set for counter value \geq comparison value

With reaching the comparison condition the *hysteresis* gets active. At active *hysteresis* the comparison result remains unchanged until the *counter value* leaves the set *hysteresis* range. After leaving the *hysteresis* range a new *hysteresis* is only activated with again reaching the comparison conditions.

Effect at counter value = comparison value

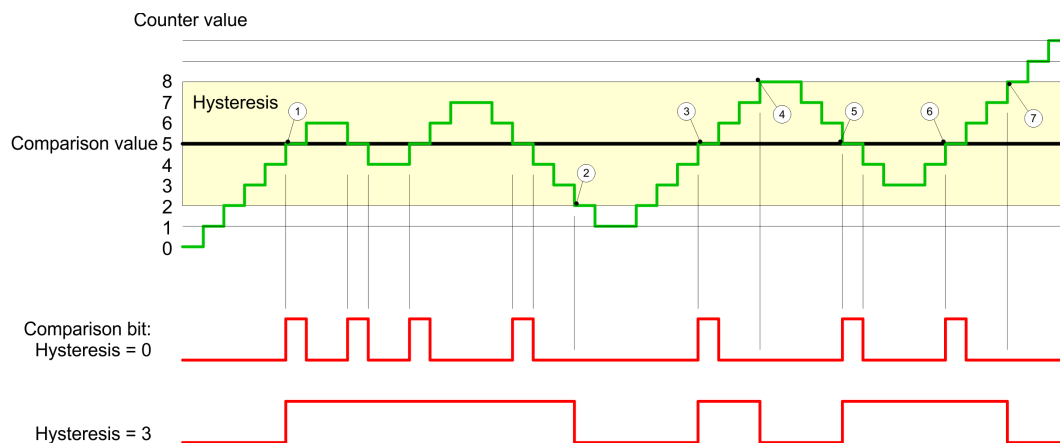

- 1 Counter value = comparison value → comparison bit is set and hysteresis activated
- 2 Leave hysteresis range → comparison bit is reset and Counter value < comparison value
- 3 Counter value = comparison value → comparison bit is set and hysteresis activated
- 4 Comparison bit is reset for leaving hysteresis range and counter value > comparison value
- 5 Counter value = comparison value → comparison bit is set and hysteresis activated
- 6 Counter value = comparison value and hysteresis active → comparison bit remains set
- 7 Leave hysteresis range and counter value > comparison value → comparison bit is reset

With reaching the comparison condition the *hysteresis* gets active. At active *hysteresis* the comparison result remains unchanged until the *counter value* leaves the set *hysteresis* range. After leaving the *hysteresis* range a new *hysteresis* is only activated with again reaching the comparison conditions.

4.6 Diagnostic and interrupt

Overview

Event	Process interrupt	Diagnostics interrupt	parameterizable
Overflow	X	-	X
Underflow	X	-	X
Comparison value	X	-	X
End value	X	-	X
Diagnostics buffer overflow	-	X	-
Process interrupt lost	-	X	-
Power supply is missing *	-	X	X

*) The module may only send a diagnostic interrupt if at the time of power loss the diagnostic interrupt was already enabled. If the power supply is already missing during startup (diagnostic interrupt is off), no diagnostic interrupt may be sent.

Process interrupt

So you may react to asynchronous events, there is the possibility to activate a process interrupt. A process interrupt interrupts the linear program sequence and jumps depending on the master system to a corresponding Interrupt routine. Here you can react to the process interrupt accordingly.

With CANopen the process interrupt data a transferred via an emergency telegram.

Operating with CPU, PROFIBUS and PROFINET the process interrupt data were transferred via diagnostics telegram.

SX - Subindex for access via EtherCAT with Index 5000h

More can be found in the according manual of your bus coupler.

Name	Bytes	Function	Default	SX
PRIT_A	1	Process interrupt data	00h	02h
PRIT_B	1	State of the inputs	00h	03h
PRIT_US	2	µs-Ticker	00h	04h ... 05h

PRIT_A Process interrupt data

Byte	Bit 7 ... 0
0	Process interrupt data <ul style="list-style-type: none"> ■ Bit 1 ... 0: reserved ■ Bit 2: Overflow, underflow or end value reached ■ Bit 3: Comparison value reached ■ Bit 7 ... 4 reserved

PRIT_B State of the inputs

Byte	Bit 7 ... 0
0	State of the inputs at the moment of the process interrupt <ul style="list-style-type: none"> ■ Bit 0: Input value channel 0 (Track A) ■ Bit 1: Input value channel 1 (Track B) ■ Bit 2: Input value channel 2 (Reset) ■ Bit 7 ... 3: reserved

PRIT_US µs-Ticker

Byte	Bit 7 ... 0
0 ... 1	Value of the µs ticker at the moment of the process interrupt

Diagnostic data

Via the parameterization you may activate a diagnostic interrupt for the module. With a diagnostic interrupt the module serves for diagnostic data for diagnostic interrupt_{incoming}. As soon as the reason for releasing a diagnostic interrupt is no longer present, the diagnostic interrupt_{going} automatically takes place. All events of a channel between diagnostic interrupt_{incoming} and diagnostic interrupt_{going} are not stored and get lost. Within this time window (1. diagnostic interrupt_{incoming} until last diagnostic interrupt_{going}) the MF-LED of the module is on.

DS - Record set for access via CPU, PROFIBUS and PROFINET. The access happens by DS 01h. Additionally the first 4 bytes may be accessed by DS 00h.

IX - Index for access via CANopen. The access happens by IX 2F01h. Additionally the first 4 bytes may be accessed by IX 2F00h.

SX - Subindex for access via EtherCAT with Index 5005h.

More can be found in the according manual of your bus coupler.

Name	Bytes	Function	Default	DS	IX	SX
ERR_A	1	Diagnostic	00h	01h	2F01h	02h
MODTYP	1	Module information	18h			03h
ERR_C	1	reserved	00h			04h
ERR_D	1	Diagnostic	00h			05h
CHTYP	1	Channel type	76h			06h
NUMBIT	1	Number diagnostics bits per channel	08h			07h
NUMCH	1	Number channels of the module	01h			08h
CHERR	1	Channel error	00h			09h
CH0ERR	1	Channel-specific error	00h			0Ah
CH1ERR... CH7ERR	7	reserved	00h			0Bh ... 11h
DIAG_US	4	µs-Ticker	00h			13h

ERR_A Diagnostic

Byte	Bit 7 ... 0
0	<ul style="list-style-type: none"> ■ Bit 0: set at module failure ■ Bit 1: set at internal error ■ Bit 2: set at external error ■ Bit 3: set at channel error ■ Bit 4: set at missing external power supply ■ Bit 7 ... 5: reserved

MODTYP Modul information

Byte	Bit 7 ... 0
0	<ul style="list-style-type: none"> ■ Bit 3 ... 0: Module class <ul style="list-style-type: none"> – 1000b: Function module ■ Bit 4: set at channel information present ■ Bit 7 ... 5: reserved

ERR_C reserved

Byte	Bit 7 ... 0
0	reserved

ERR_D Diagnostic

Byte	Bit 7 ... 0
0	<ul style="list-style-type: none"> ■ Bit 2 ... 0: reserved ■ Bit 3: set at internal diagnostics buffer overflow ■ Bit 5 ... 4: reserved ■ Bit 6: Process interrupt lost ■ Bit 7: reserved

Diagnostic and interrupt

CHTYP Channel type	Byte	Bit 7 ... 0
	0	<ul style="list-style-type: none"> ■ Bit 6 ... 0: Channel type <ul style="list-style-type: none"> – 76h: Counter module ■ Bit 7: reserved
NUMBIT Diagnostic bits	Byte	Bit 7 ... 0
	0	Number of diagnostics bits of the module per channel (here 08h)
NUMCH Channels	Byte	Bit 7 ... 0
	0	Number of channels of the module (here 01h)
CHERR Channel error	Byte	Bit 7 ... 0
	0	<ul style="list-style-type: none"> ■ Bit 0: set at error in channel group 0 ■ Bit 7 ... 1: reserved
CH0ERR Channel-specific	Byte	Bit 7 ... 0
	0	Diagnostic interrupt due to process interrupt lost at ... <ul style="list-style-type: none"> ■ Bit 1 ... 0: reserved ■ Bit 2: Overflow/underflow/end value ■ Bit 3: Comparison value reached ■ Bit 7 ... 4: reserved
CH1ERR ... CH7ERR reserved	Byte	Bit 7 ... 0
	0	reserved
DIAG_US μs ticker	Byte	Bit 7 ... 0
	0 ... 3	Value of the μ s ticker at the moment of the diagnostic