

VIPA HMI

PPC | 67S-PNL0 | Manual

HB160 | PPC | 67S-PNL0 | GB | 16-22

Panel PC - PPC021 ES

VIPA GmbH
Ohmstr. 4
91074 Herzogenaurach
Telephone: +49 9132 744-0
Fax: +49 9132 744-1864
Email: info@vipa.com
Internet: www.vipa.com

Table of contents

| | | |
|----------|--|-----------|
| 1 | General | 4 |
| | 1.1 Copyright © VIPA GmbH | 4 |
| | 1.2 About this manual..... | 5 |
| | 1.3 Safety information..... | 6 |
| 2 | Hardware description | 8 |
| | 2.1 Safety information for users..... | 8 |
| | 2.2 Properties..... | 9 |
| | 2.3 Structure..... | 10 |
| | 2.3.1 Overview..... | 10 |
| | 2.3.2 Interfaces..... | 12 |
| | 2.3.3 Memory management..... | 14 |
| | 2.4 Dimensions..... | 15 |
| | 2.5 General data..... | 17 |
| | 2.6 Technical data..... | 18 |
| | 2.6.1 67S-PNL0-JB..... | 18 |
| | 2.6.2 67S-PNL0-JX..... | 21 |
| 3 | Deployment Panel PC | 24 |
| | 3.1 Installation..... | 24 |
| | 3.2 Installation of the CFast card..... | 25 |
| | 3.3 Commissioning..... | 26 |
| | 3.3.1 VIPA Startup-Manager..... | 26 |
| | 3.4 Connection to a PLC system..... | 29 |
| | 3.5 Operating system Windows Embedded Standard 7..... | 30 |
| | 3.5.1 General..... | 30 |
| | 3.5.2 Structure..... | 31 |
| 4 | BIOS setup | 36 |
| | 4.1 Overview..... | 36 |
| | 4.2 Main..... | 37 |
| | 4.3 Advanced..... | 38 |
| | 4.4 Chipset..... | 43 |
| | 4.5 Boot..... | 46 |
| | 4.6 Security..... | 47 |
| | 4.7 Save and exit..... | 48 |
| 5 | Installation guidelines | 50 |
| | 5.1 Basic rules for the EMC-equitable assembly of installations..... | 50 |
| | 5.2 EMC-equitable assembly..... | 52 |
| | 5.3 EMC-equitable cabling..... | 53 |
| | 5.4 Special precautions providing high noise immunity..... | 56 |
| | 5.5 Checklist for the EMC-compliant installation of controllers..... | 58 |

1 General

1.1 Copyright © VIPA GmbH

All Rights Reserved

This document contains proprietary information of VIPA and is not to be disclosed or used except in accordance with applicable agreements.

This material is protected by the copyright laws. It may not be reproduced, distributed, or altered in any fashion by any entity (either internal or external to VIPA), except in accordance with applicable agreements, contracts or licensing, without the express written consent of VIPA and the business management owner of the material.

For permission to reproduce or distribute, please contact: VIPA, Gesellschaft für Visualisierung und Prozessautomatisierung mbH Ohmstraße 4, D-91074 Herzogenaurach, Germany

Tel.: +49 9132 744 -0

Fax.: +49 9132 744-1864

E-Mail: info@vipa.de

<http://www.vipa.com>



Every effort has been made to ensure that the information contained in this document was complete and accurate at the time of publishing. Nevertheless, the authors retain the right to modify the information.

This customer document describes all the hardware units and functions known at the present time. Descriptions may be included for units which are not present at the customer site. The exact scope of delivery is described in the respective purchase contract.

CE Conformity Declaration

Hereby, VIPA GmbH declares that the products and systems are in compliance with the essential requirements and other relevant provisions. Conformity is indicated by the CE marking affixed to the product.

Conformity Information

For more information regarding CE marking and Declaration of Conformity (DoC), please contact your local VIPA customer service organization.

Trademarks

VIPA, SLIO, System 100V, System 200V, System 300V, System 300S, System 400V, System 500S and Commander Compact are registered trademarks of VIPA Gesellschaft für Visualisierung und Prozessautomatisierung mbH.

SPEED7 is a registered trademark of profichip GmbH.

SIMATIC, STEP, SINEC, TIA Portal, S7-300 and S7-400 are registered trademarks of Siemens AG.

Microsoft and Windows are registered trademarks of Microsoft Inc., USA.

Portable Document Format (PDF) and Postscript are registered trademarks of Adobe Systems, Inc.

All other trademarks, logos and service or product marks specified herein are owned by their respective companies.

Information product support

Contact your local VIPA Customer Service Organization representative if you wish to report errors or questions regarding the contents of this document. If you are unable to locate a customer service centre, contact VIPA as follows:

VIPA GmbH, Ohmstraße 4, 91074 Herzogenaurach, Germany

Telefax: +49 9132 744-1204

E-Mail: documentation@vipa.de

Technical support

Contact your local VIPA Customer Service Organization representative if you encounter problems with the product or have questions regarding the product. If you are unable to locate a customer service centre, contact VIPA as follows:

VIPA GmbH, Ohmstraße 4, 91074 Herzogenaurach, Germany

Tel.: +49 9132 744-1150 (Hotline)

E-Mail: support@vipa.de

1.2 About this manual

Objective and contents

This manual describes the Panel PC 67S-PNL0-... from VIPA. It contains a description of the structure, project engineering and deployment. This manual is relevant for:

| Product | Order number | as of state: | | |
|-----------|--------------|--------------|--------|------------------------------|
| | | HW | FW | BS |
| PPC021 ES | 67S-PNL0-... | 01 | V1.0.6 | Windows® Embedded Standard 7 |

Target audience

The manual is targeted at users who have a background in automation technology.

Structure of the manual

The manual consists of chapters. Every chapter provides a self-contained description of a specific topic.

- Guide to the document** The following guides are available in the manual:
- An overall table of contents at the beginning of the manual
 - References with page numbers
- Availability** The manual is available in:
- printed form, on paper
 - in electronic form as PDF-file (Adobe Acrobat Reader)
- Icons Headings** Important passages in the text are highlighted by following icons and headings:

**DANGER!**

Immediate or likely danger. Personal injury is possible.

**CAUTION!**

Damages to property is likely if these warnings are not heeded.



Supplementary information and useful tips.

1.3 Safety information

Applications conforming with specifications

- The system is constructed and produced for:
- communication and process control
 - general control and automation tasks
 - industrial applications
 - operation within the environmental conditions specified in the technical data
 - installation into a cubicle

**DANGER!**

This device is not certified for applications in
– in explosive environments (EX-zone)

Documentation

- The manual must be available to all personnel in the
- project design department
 - installation department
 - commissioning
 - operation

**CAUTION!**

The following conditions must be met before using or commissioning the components described in this manual:

- Hardware modifications to the process control system should only be carried out when the system has been disconnected from power!
- Installation and hardware modifications only by properly trained personnel.
- The national rules and regulations of the respective country must be satisfied (installation, safety, EMC ...)

Disposal

National rules and regulations apply to the disposal of the unit!

2 Hardware description

2.1 Safety information for users

Handling of electrostatic sensitive modules

VIPA modules make use of highly integrated components in MOS-Technology. These components are extremely sensitive to over-voltages that can occur during electrostatic discharges. The following symbol is attached to modules that can be destroyed by electrostatic discharges.



The Symbol is located on the module, the module rack or on packing material and it indicates the presence of electrostatic sensitive equipment. It is possible that electrostatic sensitive equipment is destroyed by energies and voltages that are far less than the human threshold of perception. These voltages can occur where persons do not discharge themselves before handling electrostatic sensitive modules and they can damage components thereby, causing the module to become inoperable or unusable. Modules that have been damaged by electrostatic discharges can fail after a temperature change, mechanical shock or changes in the electrical load. Only the consequent implementation of protection devices and meticulous attention to the applicable rules and regulations for handling the respective equipment can prevent failures of electrostatic sensitive modules.

Shipping of modules

Modules must be shipped in the original packing material.

Measurements and alterations on electrostatic sensitive modules

When you are conducting measurements on electrostatic sensitive modules you should take the following precautions:

- Floating instruments must be discharged before use.
- Instruments must be grounded.

Modifying electrostatic sensitive modules you should only use soldering irons with grounded tips.



CAUTION!

Personnel and instruments should be grounded when working on electrostatic sensitive modules.

2.2 Properties

General

The VIPA Panel PC is a combination of industrial PC with state of the art performance features and a touch panel with ideal display capabilities. The Panel PC is a compact and modular embedded PC based on Windows® Embedded Standard 7 - WES7. Besides the extensive WES7 functions the Panel PC offers varied communication possibilities.



- Windows® Embedded Standard 7
- Movicon 11 Win Standard 7 (67S-PNL0-JB)
- 21.5" 16:9 TFT panel 16.7 M color
- PCAP, multitouch
- Display resolution 1920 x 1080
- Intel® Atom Processor D2550, Dualcore, 1.86GHz, 1M L2 Cache
- Work memory: 2x 204Pin DDR3 SO-DIMM Socket, 2GB DDR3
- User memory: 16GB SSD
- CFast slot
- 2 RS232/RS422/RS485 (switchable), 4 USB-A-, 2 Ethernet interfaces, VGA port and Audio out
- Metal case
- Passive cooling
- Easy mounting via integrated pivoted lever
- Protection class IP65 (frontal)

Order data

| Type | Order number | Description |
|-----------|--------------|---|
| PPC021 ES | 67S-PNL0-... | 21.5" TFT color, 2x RS232/RS422/RS485, 4x USB-A, 2x Ethernet RJ45, VGA, Audio out |

2.3 Structure

2.3.1 Overview

Front view

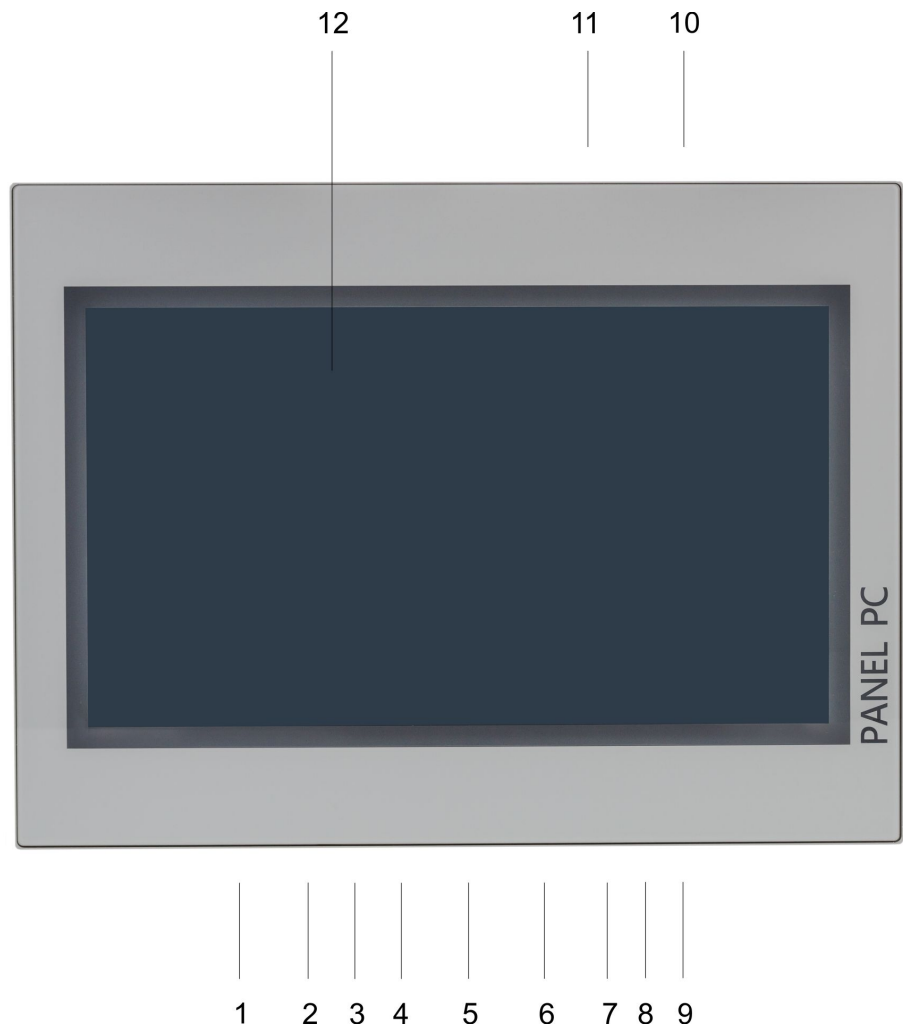

- 1 Slot for voltage supply (DC 12-30V)
- 2 VGA interface
- 3 Reset button
- 4 RS232/RS422/RS485 interface COM 2
- 5 RS232/RS422/RS485 interface COM 1
- 6 4x"Host"-USB-A interface
- 7 RJ45 jack for Ethernet communication LAN 2
- 8 RJ45 jack for Ethernet communication LAN 1
- 9 3.5mm Audio Line out
- 10 Power switch (pushbutton)
- 11 Slot for CFast storage media
- 12 Display with touch sensitive area (touch screen)

Bottom view

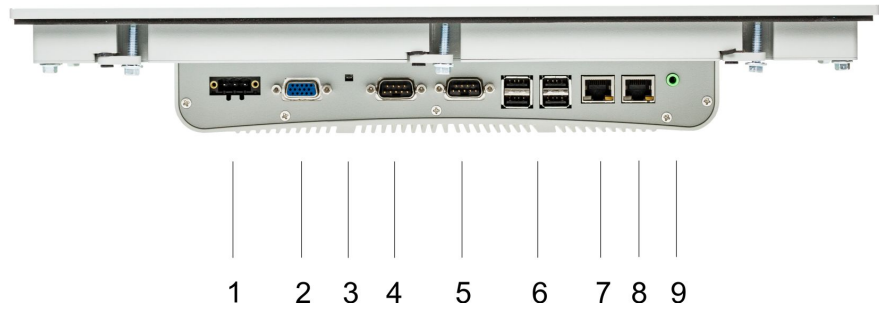

- 1 Slot for voltage supply (DC 12-30V)
- 2 VGA interface
- 3 Reset button
- 4 RS232/RS422/RS485 interface COM 2
- 5 RS232/RS422/RS485 interface COM 1
- 6 4x"Host"-USB-A interface
- 7 RJ45 jack for Ethernet communication LAN 2
- 8 RJ45 jack for Ethernet communication LAN 1
- 9 3.5mm Audio Line out



Please make sure that the Panel PC always has to be supplied with external voltage!

Top view



- 1 Slot for CFast storage media
- 2 Power switch (pushbutton)



The Panel PC starts automatically when the power supply is switched on.

But you can change the configuration in the BIOS setup so that the Panel PC has to be switched off by the power switch. ↪ 'Restore AC Power Loss' on page 45

After a Windows® 'Shut down' the Panel PC can be switched on again by means of the power switch at any time.

During operation the Panel PC switches to the sleep mode by briefly pushing the power switch. By pushing the power switch again the sleep mode is switched off.

2.3.2 Interfaces

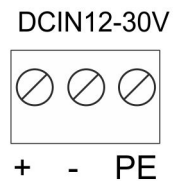
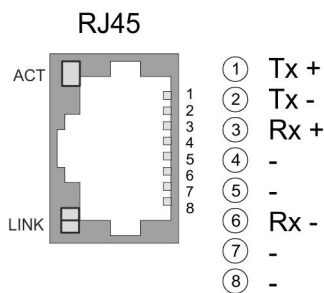
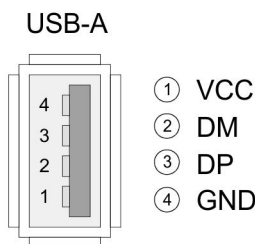
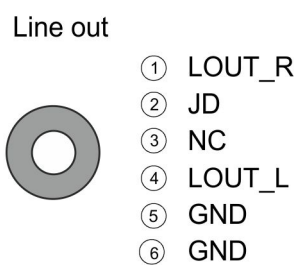
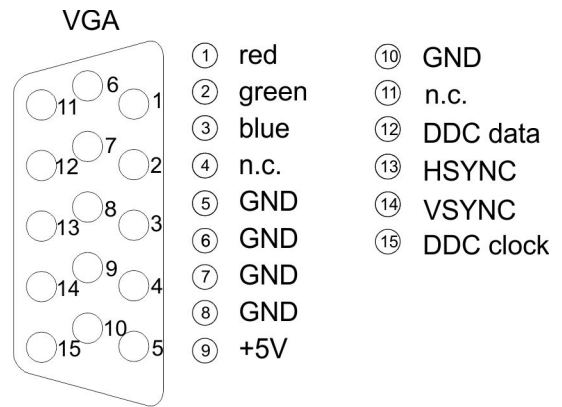
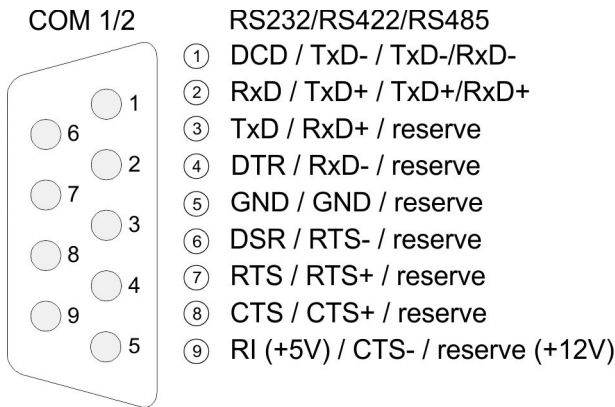

RS232/RS422/RS485 interface (switchable)

The 9-pin male SubD connector may be switched in the BIOS. Here also the termination resistor of the RS422 and RS485 interface may be activated or deactivated. ↪ 'Submenu "Serial Port 1 Configuration"' on page 42

RS232 interface

- Logical conditions as voltage level
- Point-to-point connection with serial full-duplex transfer
- Data transfer up to a distance of 15m
- Data transfer rate up to 115.2kbit/s

RS422 interface

- Logical conditions as voltage difference between 2 twisted lines
- Serial bus connection full-duplex four-wire operation
- Line length: 250m at 115.2kbit/s ... 1200m at 19.2kbit/s
- Data transfer rate up to 115.2kbit/s

RS485 interface

- Logical conditions as voltage difference between 2 twisted lines
- Serial bus connection half-duplex two-wire operation
- Line length: 250m at 115.2kbit/s ... 1200m at 19.2kbit/s
- Data transfer rate up to 115.2kbit/s

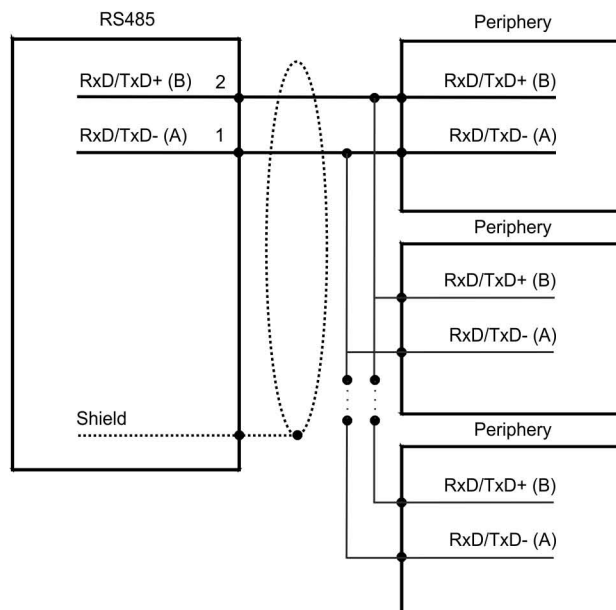
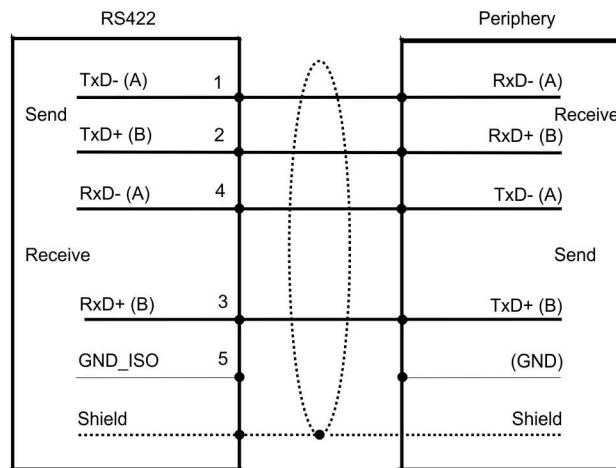
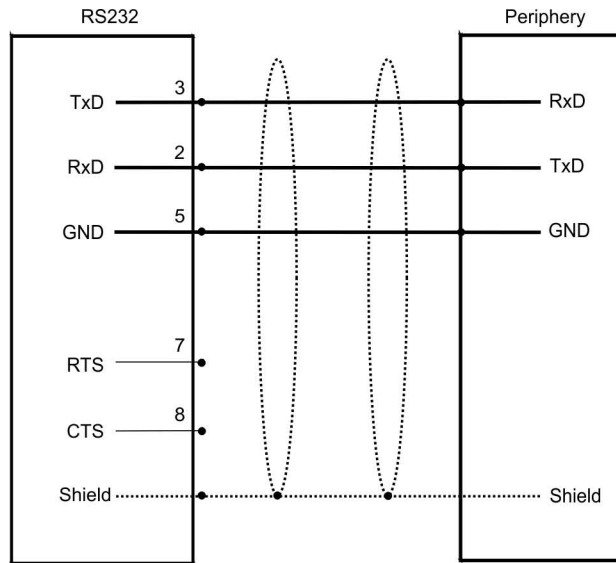



- VGA interface** VGA SubD HD15 jack to connect a second display.

- Line out** 3.5 mm stereo jack to connect an active speaker system or an ear-phone.

- "Host"-USB-A** Using the "Host"-USB-A interface USB mouse, keyboard, stick or USB hard discs can be connected.

- Ethernet connection** The two RJ45 jacks provide the interface to the twisted pair cable, required for Ethernet.

LEDs

| ACT | Status | LINK | Status |
|--|---------------|--|--------------------------|
| blinks yellow  | communication | green  | 1000Mbit/s link |
| off | not active | orange  | 100Mbit/s link |
| | | off | 10Mbit/s link or no link |

- Power supply** The Panel PC has got an integrated power supply. The power supply has to be provided with DC 12... 30V. For this you find an according DC 24V slot at the back. The power supply is protected against inverse polarity and overcurrent.

2.3.3 Memory management

Overview

- 2GB work memory
- 16GB SSD user memory
- USB storage media using "Host"-USB-A interface
- Slot for CFast memory card

- Work memory** The Panel PC has a work memory with a size of 2GB. The work memory is not buffered and is deleted after shut down.

- User memory** As internal permanent storage medium the Panel PC has a 16GB flash module (7GB user data).

- USB storage media** The Panel PC has got four USB 2.0 interfaces. The connection of USB sticks and USB drives are supported by the Panel PC.

- Slot for CFast** At the back of the Panel PC there is a card slot for a memory card. At this slot you can plug storage modules of the type CFast 2.0 - 600 MB/s (6Gbit/s) - SATA protocol - not hot-swap compatible.

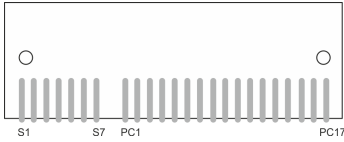

| Pin | Assignment | Pin | Assignment |
|-----|------------|------|--------------|
| S1 | GND | PC6 | n.c. |
| S2 | SATA_TX1+ | PC7 | GND |
| S3 | SATA_TX1- | PC8 | CFAST_LED1_C |
| S4 | GND | PC9 | CFAST_LED2_C |
| S5 | SATA_RX1+ | PC10 | n.c. |
| S6 | SATA_RX1- | PC11 | n.c. |
| S7 | GND | PC12 | n.c. |
| PC1 | CFAST_CDI | PC13 | VCC3 |
| PC2 | GND | PC14 | VCC3 |
| PC3 | n.c. | PC15 | GND |
| PC4 | n.c. | PC16 | GND |
| PC5 | n.c. | PC17 | CFAST_CDO |



Prior to removing the CFast card, make sure the unit's power is off and disconnected from the power supply.

2.4 Dimensions

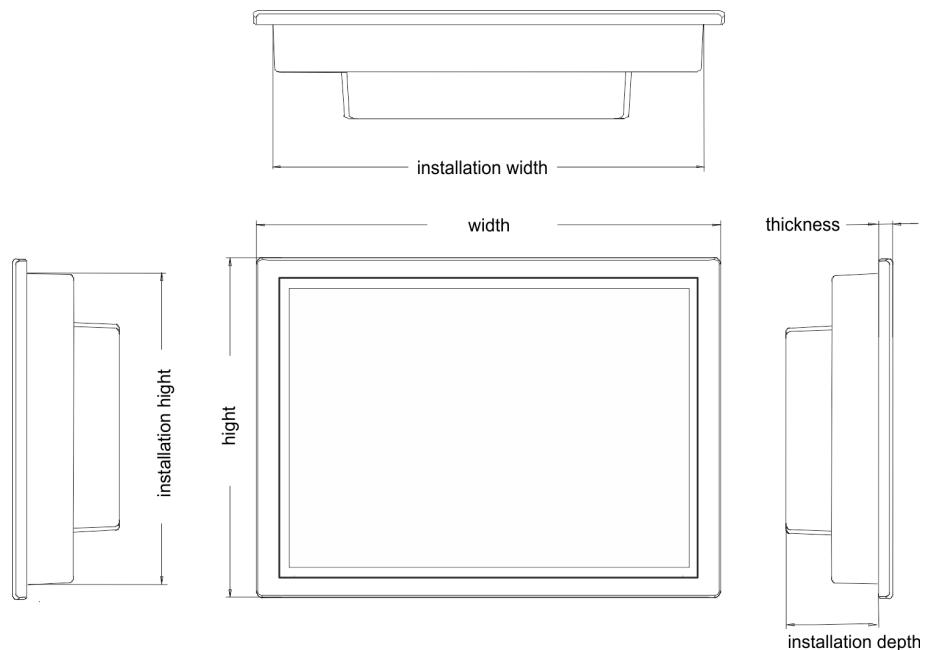

Installation dimensions

For the installation of the Panel PC in control cabinets and desks the following dimensions are necessary:

Dimensions

21.5" - 67S-PNL0-...

| | |
|------------------------------|--------------------------|
| Front panel thickness | 3 ... 12mm |
| Installation cutting (W x H) | 547 x 367mm |
| Front panel (W x H x T) | 562.40 x 382.40 x 6.70mm |
| Rear panel (W x H x D) | 542 x 362 x 54.20mm |
| Installation depth | 54.20mm |



The degrees of protection are only guaranteed when the following is observed:

- The material thickness of the installation cut-out is 3 ... 12mm*
- The deviation from the plane for the panel cut-out is $\leq 0.5\text{mm}$*
- Permissible surface roughness in the area of the seal: $\leq 120\mu\text{m}$ (friction coefficient 120)*

2.5 General data

Conformity and approval

| | | |
|------------|------------|---|
| Conformity | | |
| CE | 2014/35/EU | Low-voltage directive |
| | 2014/30/EU | EMC directive |
| Approval | | |
| UL | | Refer to Technical Data |
| others | | |
| RoHS | 2011/65/EU | Product is lead-free; Restriction of the use of certain hazardous substances in electrical and electronic equipment |

Protection of persons and device protection

| | | |
|---------------------------------------|---|-----------------------------------|
| Type of protection | - | IP20 |
| Electrical isolation | | |
| to the field bus | - | electrically isolated |
| to the process level | - | electrically isolated |
| Insulation resistance | | - |
| Insulation voltage to reference earth | | |
| Inputs / outputs | - | AC / DC 50V, test voltage AC 500V |
| Protective measures | - | against short circuit |

Environmental conditions to EN 61131-2

| | | |
|-------------------------|---------------|---|
| Climatic | | |
| Storage / transport | EN 60068-2-14 | -20...+75°C |
| Operation | | |
| Horizontal installation | EN 61131-2 | 0...+50°C |
| Vertical installation | EN 61131-2 | 0...+50°C |
| Air humidity | EN 60068-2-30 | RH1 (without condensation, rel. humidity 10... 95%) |
| Pollution | EN 61131-2 | Degree of pollution 2 |
| Mechanical | | |
| Oscillation | EN 60068-2-6 | 1g, 9Hz ... 150Hz |
| Shock | EN 60068-2-27 | 15g, 11ms |

Mounting conditions

| | | |
|-------------------|---|-------------------------|
| Mounting place | - | In the control cabinet |
| Mounting position | - | Horizontal and vertical |

| EMC | Standard | Comment |
|-----------------------|--------------|---|
| Emitted interference | EN 61000-6-4 | Class A (Industrial area) |
| Noise immunity zone B | EN 61000-6-2 | Industrial area |
| | EN 61000-4-2 | ESD 8kV at air discharge (degree of severity 3), 4kV at contact discharge (degree of severity 2) |
| | EN 61000-4-3 | HF field immunity (casing) 80MHz ... 1000MHz, 10V/m, 80% AM (1kHz) 1.4GHz ... 2.0GHz, 3V/m, 80% AM (1kHz) 2GHz ... 2.7GHz, 1V/m, 80% AM (1kHz) |
| | EN 61000-4-6 | HF conducted 150kHz ... 80MHz, 10V, 80% AM (1kHz) |
| | EN 61000-4-4 | Burst, degree of severity 3 |
| | EN 61000-4-5 | Surge, installation class 3 * |

*) Due to the high-energetic single pulses with Surge an appropriate external protective circuit with lightning protection elements like conductors for lightning and overvoltage is necessary.

2.6 Technical data**2.6.1 67S-PNL0-JB**

| Order no. | 67S-PNL0-JB |
|--------------------------|------------------------------|
| Type | Panel PC PPC021 ES |
| Display | |
| Display size (diagonal) | 21.5 " |
| Display size (width) | 478 mm |
| Display size (height) | 269 mm |
| Resolution | 1920 x 1080 |
| Aspect ratio | 16:9 |
| Type of display | TFT color (16.7M colors) |
| MTBF Backlights (25°C) | 50000 h |
| System properties | |
| Processor | Intel Atom Dualcore 1.86 GHz |

| Order no. | 67S-PNL0-JB |
|-------------------------------------|-----------------------------|
| Operating system | Windows embedded Standard 7 |
| User software | Movicon 11 Win Standard |
| Work memory | 2 GB |
| User memory | 16 GB |
| Available memory (user data) | 7 GB |
| SD/MMC Slot | - |
| CF Card Slot Typ II | - |
| CFast Slot | ✓ |
| Time | |
| Real-time clock buffered | ✓ |
| Clock buffered period (min.) | 4 y |
| Type of buffering | lithium battery |
| Load time for 50% buffering period | - |
| Load time for 100% buffering period | - |
| Accuracy (max. deviation per day) | 10 s |
| Operating controls | |
| Touchscreen | PCAP |
| Touch function | Dual Touch |
| Keyboard | external via USB |
| Mouse | external via USB |
| Interfaces | |
| MPI, PROFIBUS-DP | - |
| MPI, PROFIBUS-DP connector | - |
| Serial, COM1 | RS232 / RS422 / RS485 |
| COM1 connector | Sub-D, 9-pin, male |
| Serial, COM2 | RS232 / RS422 / RS485 |
| COM2 connector | Sub-D, 9-pin, male |
| Number of USB-A interfaces | 4 |
| USB-A connector | USB-A (host) |
| Number of USB-B interfaces | - |
| USB-B connector | - |
| Number of ethernet interfaces | 2 |
| Ethernet | Ethernet 10/100/1000 MBit |
| Ethernet connector | 2 x RJ45 |
| Integrated ethernet switch | - |
| Video connectors | VGA SubD HD15 |

| Order no. | 67S-PNL0-JB |
|--|------------------------------|
| Audio connections | Line out, stereo jack 3.5 mm |
| Technical data power supply | |
| Power supply (rated value) | DC 24 V |
| Power supply (permitted range) | DC 20.4...28.8 V |
| Reverse polarity protection | ✓ |
| Current consumption (no-load operation) | 1.2 A |
| Current consumption (rated value) | 1.3 A |
| Inrush current | 1.3 A |
| I^2t | 0.35 A ² s |
| Power loss | 32 W |
| Status information, alarms, diagnostics | |
| Supply voltage display | none |
| Mechanical data | |
| Housing / Protection type | |
| Material | coated aluminium steel plate |
| Mounting | via integrated pivoted lever |
| Protect type front side | IP 65 |
| Protect type back side | IP 20 |
| Dimensions | |
| Front panel | 562.4 mm x 382.4 mm x 6.7 mm |
| Rear panel | 542 mm x 362 mm x 54.2 mm |
| Installation cut-out | |
| Width | 547 mm |
| Height | 367 mm |
| Minimum | 3 mm |
| Maximum front panel thickness | 12 mm |
| Weight | 9.1 kg |
| Environmental conditions | |
| Operating temperature | 0 °C to 50 °C |
| Storage temperature | -20 °C to 75 °C |
| Certifications | |
| UL certification | yes |
| KC certification | - |

2.6.2 67S-PNL0-JX

| Order no. | 67S-PNL0-JX |
|-------------------------------------|------------------------------|
| Type | Panel PC PPC021 ES |
| Display | |
| Display size (diagonal) | 21.5 " |
| Display size (width) | 478 mm |
| Display size (height) | 269 mm |
| Resolution | 1920 x 1080 |
| Aspect ratio | 16:9 |
| Type of display | TFT color (16.7M colors) |
| MTBF Backlights (25°C) | 50000 h |
| System properties | |
| Processor | Intel Atom Dualcore 1.86 GHz |
| Operating system | Windows embedded Standard 7 |
| User software | - |
| Work memory | 2 GB |
| User memory | 16 GB |
| Available memory (user data) | 7 GB |
| SD/MMC Slot | - |
| CF Card Slot Typ II | - |
| CFast Slot | ✓ |
| Time | |
| Real-time clock buffered | ✓ |
| Clock buffered period (min.) | 4 y |
| Type of buffering | lithium battery |
| Load time for 50% buffering period | - |
| Load time for 100% buffering period | - |
| Accuracy (max. deviation per day) | 10 s |
| Operating controls | |
| Touchscreen | PCAP |
| Touch function | Dual Touch |
| Keyboard | external via USB |
| Mouse | external via USB |
| Interfaces | |
| MPI, PROFIBUS-DP | - |
| MPI, PROFIBUS-DP connector | - |
| Serial, COM1 | RS232 / RS422 / RS485 |

| Order no. | 67S-PNL0-JX |
|--|------------------------------|
| COM1 connector | Sub-D, 9-pin, male |
| Serial, COM2 | RS232 / RS422 / RS485 |
| COM2 connector | Sub-D, 9-pin, male |
| Number of USB-A interfaces | 4 |
| USB-A connector | USB-A (host) |
| Number of USB-B interfaces | - |
| USB-B connector | - |
| Number of ethernet interfaces | 2 |
| Ethernet | Ethernet 10/100/1000 MBit |
| Ethernet connector | 2 x RJ45 |
| Integrated ethernet switch | - |
| Video connectors | VGA SubD HD15 |
| Audio connections | Line out, stereo jack 3.5 mm |
| Technical data power supply | |
| Power supply (rated value) | DC 24 V |
| Power supply (permitted range) | DC 20.4...28.8 V |
| Reverse polarity protection | ✓ |
| Current consumption (no-load operation) | 1.2 A |
| Current consumption (rated value) | 1.3 A |
| Inrush current | 1.3 A |
| I^2t | 0.35 A ² s |
| Power loss | 32 W |
| Status information, alarms, diagnostics | |
| Supply voltage display | none |
| Mechanical data | |
| Housing / Protection type | |
| Material | coated aluminium steel plate |
| Mounting | via integrated pivoted lever |
| Protect type front side | IP 65 |
| Protect type back side | IP 20 |
| Dimensions | |
| Front panel | 562.4 mm x 382.4 mm x 6.7 mm |
| Rear panel | 542 mm x 362 mm x 54.2 mm |
| Installation cut-out | |
| Width | 547 mm |
| Height | 367 mm |

| | |
|---------------------------------|--------------------|
| Order no. | 67S-PNL0-JX |
| Minimum | 3 mm |
| Maximum front panel thickness | 12 mm |
| Weight | 9.1 kg |
| Environmental conditions | |
| Operating temperature | 0 °C to 50 °C |
| Storage temperature | -20 °C to 75 °C |
| Certifications | |
| UL certification | yes |
| KC certification | - |

3 Deployment Panel PC

3.1 Installation

Overview

The Panel PC is suitable for the installation in operating tables and control cabinet fronts. The installation happens via the back. The Panel PC is provided with a fixing technique with not losable screws that allows an easy connection with a crosstip screwdriver. A fast and easy device change is possible. It is also possible to install the Panel PC in a VESA holder (100mm x 100mm).

Installation cutting

For the installation into a operating tableau and control cabinet fronts, the Panel PC requires the following front panel cutting:

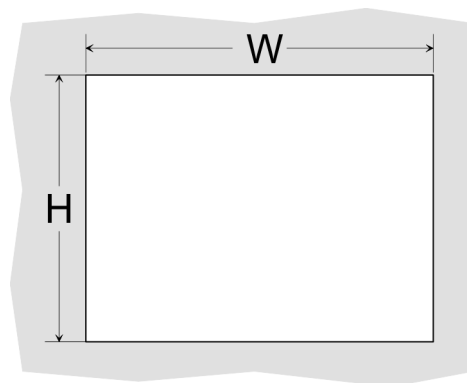

| Panel PC | W x H in mm |
|--------------|-------------|
| 67S-PNL0-... | 547 x 367mm |



The material thickness of the installation cut-out is 3 ... 12mm.

Installation

For the installation of the panel pivoted lever are integrated. For the installation, a small slit screwdriver is required.

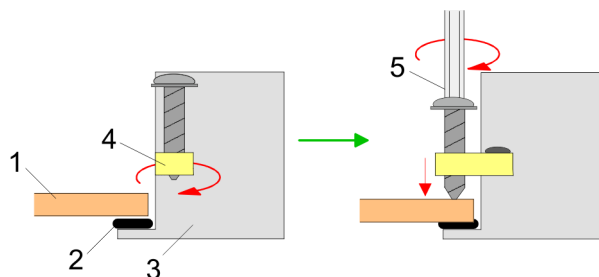

1. ► Push the Panel PC [3] from the front side into the front panel cutting [1] until it touches the panel with the seal [2].
2. ► Rotate the pivoted lever 90 degrees to the outside [4].
3. ► Screw the screws with the crosstip screwdriver [5].

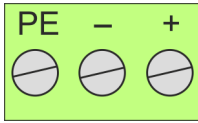
Connect power supply

For the cabling of the power supply DC 12-30V a green plug is used. The connector is a plug with screw contacts. The plug has the following assignment:

- + DC 24V
- DC 0V
- PE Protective earth

3.2 Installation of the CFast card**Installation**

The CFast card slot is located on the rear top side of the Panel PC. It is closed with a cover plate.



1. ▶ Remove the cover plate of the slot by removing the screws and pulling the plate.



2. ▶ With the label facing up, insert the CFast card until it is completely seated in the slot and reinstall the cover plate.
⇒ After installation the CFast card is automatically recognized.

**Demounting**

1. ▶ Remove the screws.
2. ▶ Pull the holding plate from the card slot.
3. ▶ Push the CFast card to remove the card.
4. ▶ Reinstall the cover plate.

**CAUTION!**

Prior to removing the CFast card, make sure the unit's power is off and disconnected from the power supply.

3.3 Commissioning



CAUTION!

- Before commissioning the device must be brought to room temperature.
- At condensation the device must be absolutely dry before connected to power.
- To avoid overheat during operation the device must not be laid open to direct sun light.
- After opening the control cabinet or desk, there are parts with possible dangerous voltage available.
- For all signal connections only screened cables are permitted.
- Signal cables must not be let within the same cable shaft as high voltage cables.

3.3.1 VIPA Startup-Manager

Start screen

As soon as the Panel PC is provided by power supply, the *VIPA Startup-Manager* will be loaded. At the first startup of the *VIPA Startup-Manager* the following *start screen* appears.

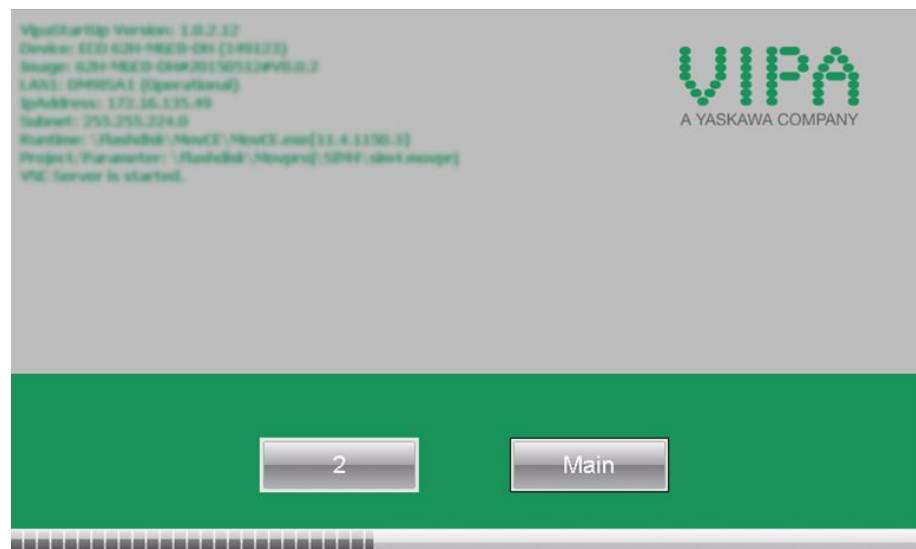

- There is a button on the *initial screen* with a counter, which counts backwards. If you click on this button within this time, the project will start. If the time expires, the project will start automatically. With the button [Main] you get to the *selection menu*.
- A delay time of 5 seconds is default. In the *selection menu* under [Autostart] you can adjust this time.

Selection menu

There are following buttons in the *selection menu*:

- Settings
- Info/Update
- Autostart
- Backup
- Exit
- Back

Settings

- In [Settings] under '*Change Settings*' you can set a password for the Startup-Manager. The password will be requested when interrupting the start countdown. By default, no password is defined. In [Settings] the system settings can be set exactly like via Windows '*Start → Control Panel*'.
- Under *Backlight control* you can adjust the brightness and dimming of the backlight.

Info/Update (firmware)

- To execute the firmware update press the button [Info/Update]. After clicking [Info/Update] the current image is displayed under '*Image Version*' with panel name, creation date and version number. With [Create Screenshot] you can make a screen shot of the panel information and select a destination for its storage.
- To execute the firmware update an external keyboard and an USB stick in NTFS format (memory size 4GB) is necessary. The new image file for your Panel PC should be on the USB stick. You will find the file under www.vipa.com in the download area.

1. ▶ Insert the USB stick into USB port of the Panel PC and connect the keyboard.
2. ▶ Click [Search Image...].
 - ⇒ The images found will be listed. This may take a few seconds.
3. ▶ Select the new image.
 - ⇒ If the selected image is not suitable for your Panel PC, an error message will appear.
4. ▶ Leave the USB stick and the keyboard plugged.
5. ▶ Click [Update Image] to execute the update.
 - ⇒ The Panel PC starts after 5 seconds.
6. ▶ Press [F7] during the boot-process on the external keyboard.
 - ⇒ The "Boot menu" appears.
7. ▶ Select the USB stick as boot medium in the "Boot menu" and confirm with [ENTER]
 - ⇒ The "VIPA Backup/Restore Tool" starts.
8. ▶ Confirm with [Yes].
 - ⇒ The update process starts. This may take a few seconds.
9. ▶ After the successful update a message appears. Confirm with [OK] to complete the update.
 - ⇒ The Panel PC restarts.

Autostart

With [Autostart] you define which runtime and which project will be started automatically together with the panel startup.

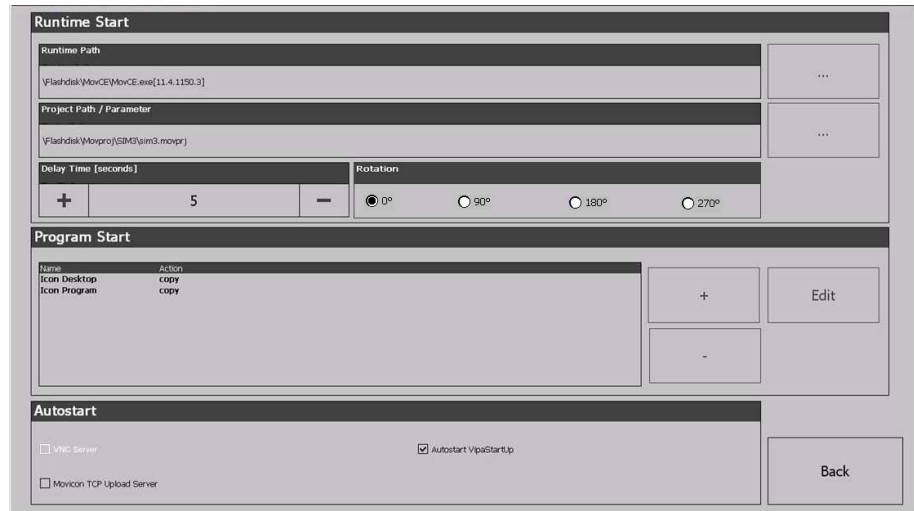

- With [...] at 'Runtime path' res. 'Project path' all existing runtimes res. projects on the panel and the storage media will be listed.
- Under 'Delay Time' you can adjust a delay time > 0 by using the buttons [+] and [-]. 5 seconds are default.
- Via 'Rotation' the orientation of the panel can be changed.
- Via 'Program Start' with [+] you can add programmes, which have to start automatically.

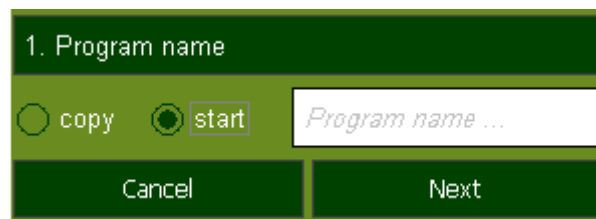

1. Select 'Start' and assign a name for the program.

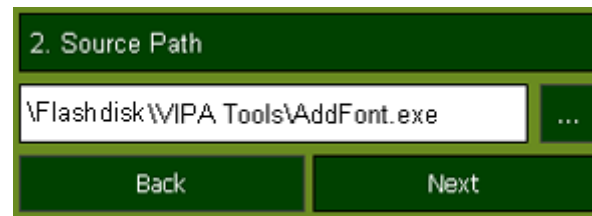

2. Upload your program with [...].

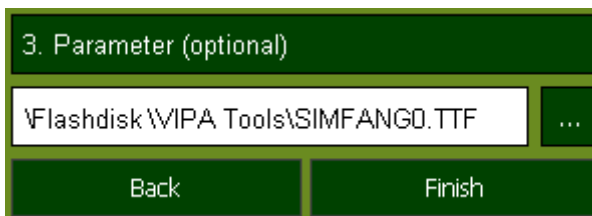

3. You can optionally set parameters.
4. Exit with [Finish].

- With 'Copy' [...] files can be copied on the panel from a source path to a destination path.
- With 'Autostart' you can select the automatic startup of the Movicon-TCP upload server, the VNC server und the VIPA Startup-Manager. With [Back] you can return to the *select menu*.

Backup

By default, the configuration of the Startup-Manager, the registry settings for the backlight, the local settings and the LAN settings will be saved by [Backup] in 'Flashdisk → Backup'. The name of the backup file is "backup.bkv". Which settings will be saved and the storage location are defined in the file "ToDoList.xml" under 'Flashdisk → VipaStartup'. These can be adjusted accordingly.

Exit

The VIPA Startup-Manager will be closed by [Exit] and the system returns to the Windows® screen.

Back

With [Back] you get back to the start screen of the *VIPA Startup-Manager*.

3.4 Connection to a PLC system

Overview

- For the inclusion into your PLC system several HMI/SCADA project-engineering platforms are at your disposal that has to be installed at an external PC. Here you may create your project, where appropriate simulate it and transfer it to the Panel PC that you've entered before. Via the at the Panel PC pre-installed runtime version of the HMI/SCADA project engineering platforms your project is run able.
- By using the according communication driver, the Panel PC supports connecting options to the PLC via Ethernet.
- During operation your operating device communicates with the according PLC and reacts to the application courses in the PLC according to the configured processes. Via dialogues configured before, process values may be monitored graphically, altered and evaluated.

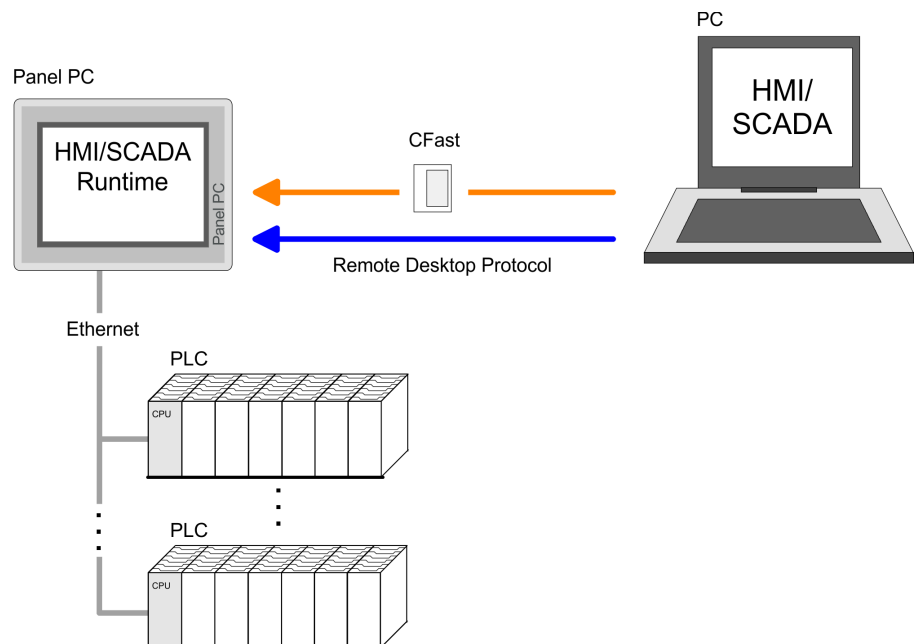

3.5 Operating system Windows Embedded Standard 7

3.5.1 General

Windows® Embedded Standard 7 - WES7 - delivers all the power, familiarity, and reliability of the Windows 7 operating system in a componentized form.

Features

- ftp-Server and IIS-Webserver
- File viewer for Word and Excel
- RDP (Remote Desktop Protocol)
- Internet Explorer
- WordPad
- Mouse pointer
- USB keyboard driver

Differences to the standard Windows® operation

Please regard that for the deployment of Windows® Embedded Standard 7 a thorough knowledge of operating Windows® are assumed. Here are only shown the differences to a "standard" Windows® operating system.

Pen entry

You're operating the Panel by means of a pencil for capacitive touch screen res. with the finger. When touching an area at the touch screen this area is recognized and the program reacts accordingly. The following types of entry are differentiated:

- *Double click*
A double click has to be executed like mouse operation by touching the area at the screen twice. A double click on an object opens res. executes this.
- *Drag*
By tapping on an object and then dragging you may move the object on the screen. If no object is selected, a frame is created by the dragging that selects the touched objects.

Mouse functions

In this version mouse functions are fully supported. As soon as the touch screen is touched with the pen, a mouse pointer is shown on the desktop at the pen position.

Navigation within the dialog window

The windows may be moved via the head bar. Here you may also find the [OK] button to confirm entries and the [X] button for exiting the dialog.

Exit WES7 (shut down)

Don't turn off the Panel PC with the power switch. Always exit WES7 via "Shut down".

3.5.2 Structure

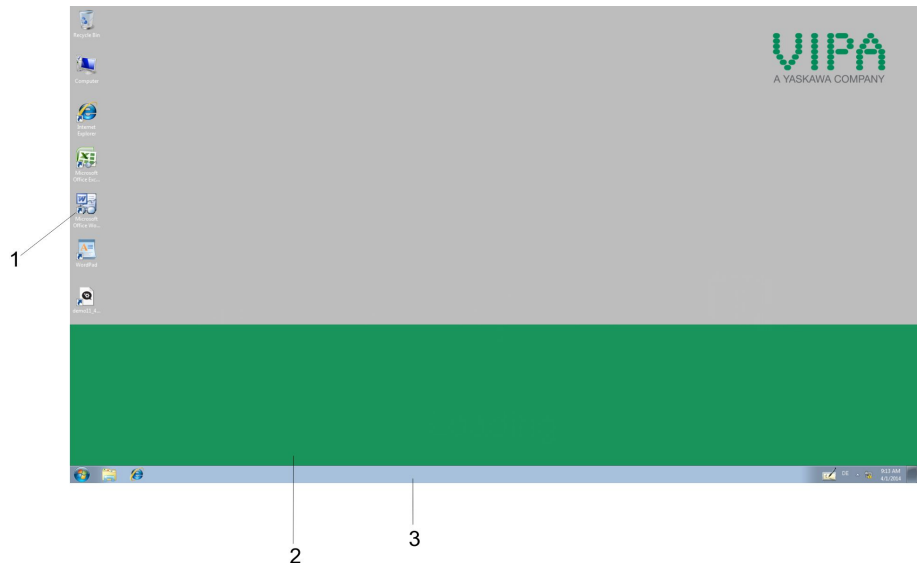

| | | |
|---|-----------------|---|
| 1 | <i>Icon</i> | Via icons on the desktop you gain direct access to the application related to the icon. |
| 2 | <i>Desktop</i> | The desktop is the screen that is shown after login at Windows [®] . It contains e.g. links to the mostly used applications res. system components. |
| 3 | <i>Task bar</i> | The task bar is part of the desktop. When opening an application, a document or a window, every running object is displayed as button on the task bar. Via this buttons you may easily change between the open windows. |

Task bar

Basically the taskbar has the following structure:



| | | |
|---|--------------------------|--|
| 1 | <i>Start button</i> | This button offers you access to all components of your Panel PC such as applications, system settings, file browser etc. |
| 2 | <i>Windows Explorer</i> | The Windows Explorer is shown. |
| 3 | <i>Internet Explorer</i> | The Internet Explorer is shown. |
| 4 | <i>Open applications</i> | For every open application a button is to be found in the task bar. The switch between the applications is performed via this buttons. |
| 5 | <i>Software keyboard</i> | This button displays a keyboard at the screen. |
| 6 | <i>Keyboard layout</i> | If you've connected a keyboard you may choose the requested language layout via this button. |

| | | |
|---|---------------------------|--|
| 7 | <i>Network connection</i> | As soon as your Panel PC is connected via Ethernet you can see here the Ethernet address. If there is no connection via Ethernet, the symbol is displayed crossed out. |
| 8 | <i>Time, Date</i> | This area shows time and date that you may change via double click. |

Software keyboard

The button  allows you to select a software keyboard. The software keyboard allows you to enter key entries without connecting an external keyboard. As soon as an entry is required the software keyboard is automatically shown.

At the moment the following keyboards are implemented:

Software Keyboard

The button  allows you to select the normal software keyboard.



Expanded Software Keyboard

Via 'Tools → Show expanded keyboard' you may open the expanded keyboard.

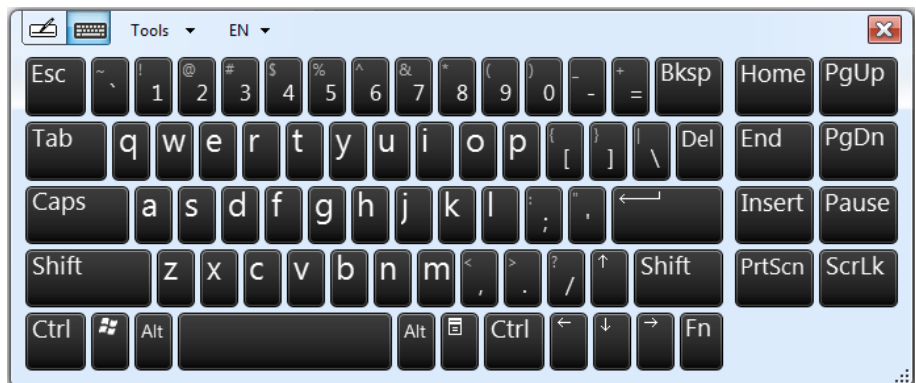

Control Panel

The description of the *Control Panel* components relevant for operating the Panel PC can be found in the following:

- *Change display language*

Per default, the PC is delivered with the display language "English". You can change the language in 'Start → Control Panel → Clock, Language and Region → Change display language'.

- *Ethernet parameters*

The dialog field for pre-setting an Ethernet address can be found in 'Start → Control Panel → Network and Internet → Network and Sharing Center → Change adapter settings'. By double-click on the network the dialog window for network properties opens. Here you can enter the Ethernet address via [Properties] after double-click on [Internet Protocol Version ..]. The default setting is address assignment via DHCP.

- *Switch function*

If you select both Ethernet adapters under 'Start → Control Panel → Network and Internet → Network and Sharing Center → Change adapter settings', you can establish a network bridge via 'Bridge Connections' in the context menu. A further Ethernet adapter called 'Network Bridge' will be displayed. Here you can make all settings.

- *System properties*

Via 'Start → Settings → System and Security → System' you receive information about the version of the current Windows® operating system and the copyright.

Via 'System Protection' or 'Change settings' under 'Change' you can change the device name that is shown during Ethernet communication for instance.

- *Allow remote access*

By default, remote access to the Panel PC is disabled. For release, open the window 'Remote' via 'Start → Control Panel → System and Security → System → Allow remote access', choose one of the release options and confirm with [OK].

Disable automatic log-in

By default, the Panel PC automatically logs in with the user name *VIPA* and the password *vipatp*. If the user needs to enter name and password to use the Panel PC, the procedure is as follow:

1. ▶ Type "cmd" under 'Start → Run'.

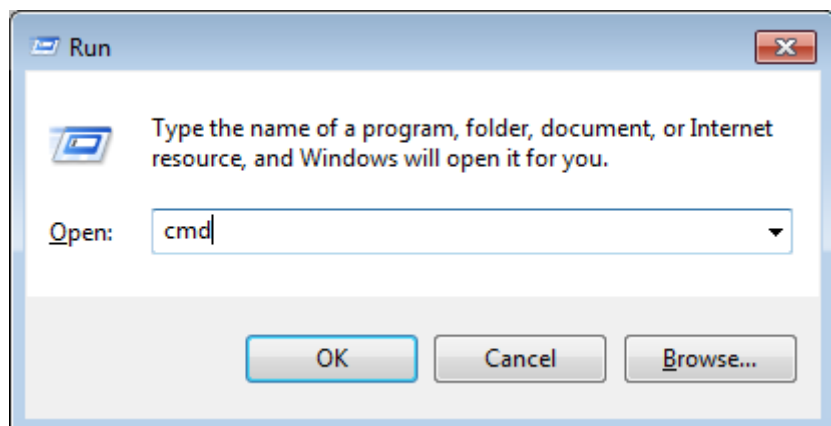

2. ▶ In the next window type "control userpasswords2".

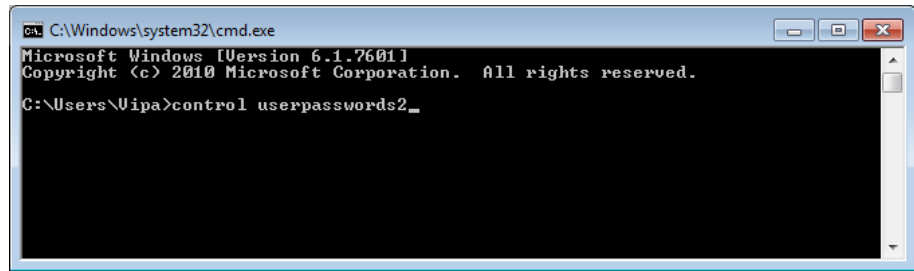

3. In the opening dialog window check the box 'User must enter a user name and password to use this computer.' and confirm with [Apply]. You can also change the password in this section under [Reset Password] at any time.

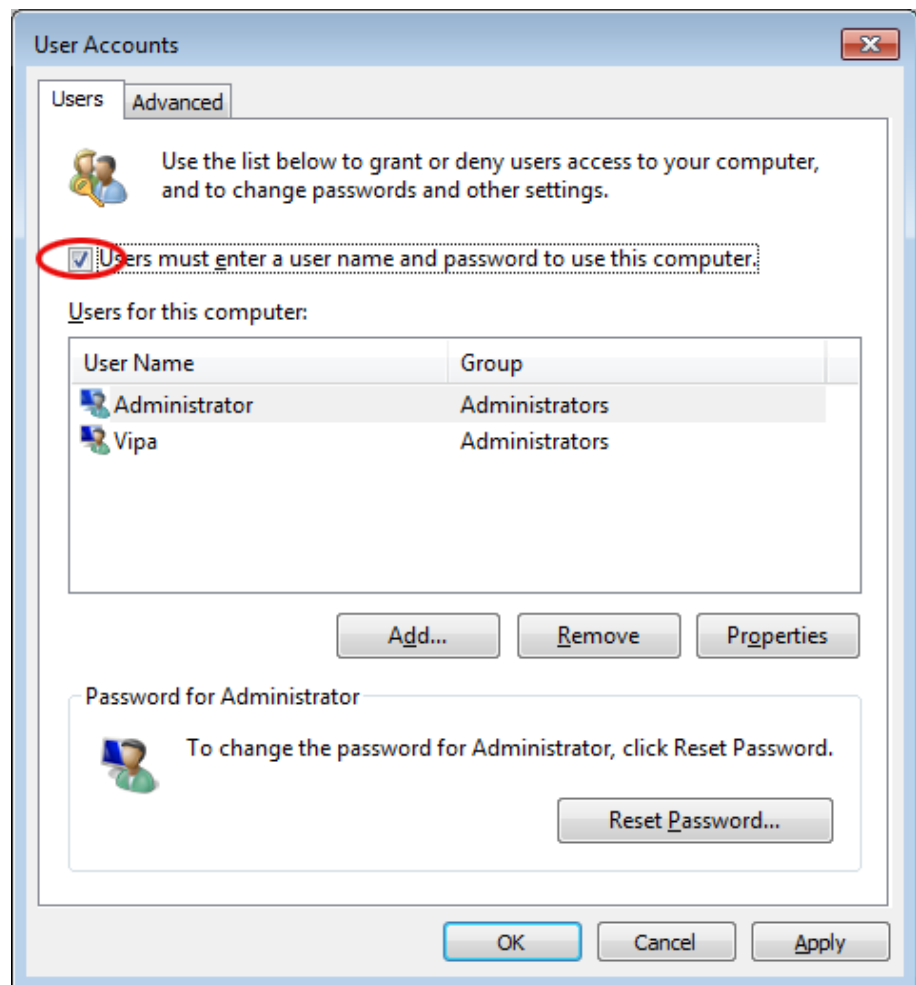

At the next start-up the user has to select the user name and enter the 'Password'.

Enable automatic log-in

1. Type "cmd" under 'Start → Run'.
2. In the next window type "control userpasswords2".
3. In the opening dialog window uncheck the box 'User must enter a user name and password to use this computer.' and confirm with [Apply].
4. A new dialog window opens asking you to enter the log-in data. Select here your 'User Name' and enter the corresponding 'password'. Confirm with [OK].

The next start-up takes place without requesting the log-in data.

Enhanced Write Filter

The *'Enhanced Write Filter'* is a tool which can be used to disable permanent writing accesses to the internal drive "C:". It can be written to the drive but the data is not stored permanently.

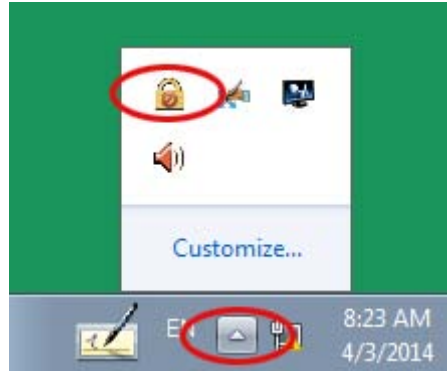

1. ▶ Open the configuration window of the Enhanced Write Filter by clicking  icon in the system tray.
2. ▶ In the next window click on [Configure].
3. ▶ In the following window select *enable* under *'Pending command'* to enable the Enhanced Write Filter.

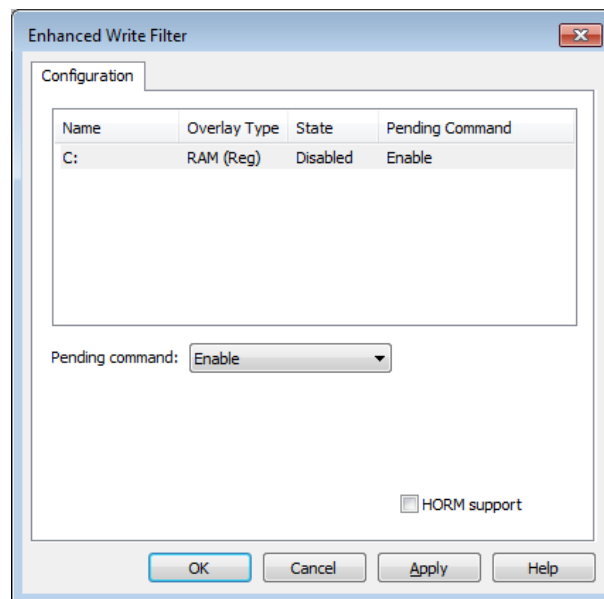

4. ▶ Confirm with [Apply] and [OK].
5. ▶ To disable the Enhanced Write Filters select *Commit and disable live* under *'Pending command'*.



Please note that a status change of the Enhanced Write Filter will only take effect after a restart of the system.

4 BIOS setup

4.1 Overview

- In this chapter you will find information, required for calling the BIOS setup and the possible settings.
- The BIOS (Basic Input and Output System) setup program is a menu driven utility that enables you to make changes to the system configuration and tailor your system to suit your individual work needs. It is a ROM-based configuration utility that displays the system's configuration status and provides you with a tool to set system parameters.
- These parameters are stored in non-volatile battery-backed-up CMOS RAM that saves this information even when the power is turned off. When the system is turned back on, the system is configured with the values found in CMOS.
- With easy-to-use pull down menus, you can configure such items as:
 - Hard drives, diskette drives, and peripherals
 - Video display type and display options
 - Password protection from unauthorized use
 - Power management features

Configure the BIOS

This program should be executed under the following conditions:

- Changing the system configuration
- A configuration error is detected by the system and you are prompted to make changes to the setup program
- Resetting the system clock
- Redefining the communication ports to prevent any conflicts
- Making changes to the power management configuration
- Changing the password or making other changes to the security setup

Normally, CMOS setup is needed when the system hardware is not consistent with the information contained in the CMOS RAM, whenever the CMOS RAM has lost power or the system features need to be changed.

Default Configuration

Most of the configuration settings are either predefined according to the '*Load Optimal Defaults*' settings which are stored in the BIOS or are automatically detected and configured without requiring any actions. There are a few settings that you may need to change depending on your system configuration.

Entering BIOS setup

When the system is powered on, the BIOS will enter the Power-On Self Test (POST) routines. These routines perform various diagnostic checks; if an error is encountered, the error will be reported in one of two different ways:

- If the error occurs before the display device is initialized, a series of beeps will be transmitted.
- If the error occurs after the display device is initialized, the screen will display the error message.

Powering on the computer and immediately pressing *[Del]* allows you to enter Setup.

Selection boot medium Powering on the computer and immediately pressing *[F7]* allows you, as long as the loading screen is shown, to change to the boot medium selection.

Legends

| Key | Function |
|-----------|---|
| ←→ | Moves the highlight left or right to select a menu |
| ↑↓ | Moves the highlight up or down between sub-menus or fields |
| Ecs | Exits the BIOS setup utility |
| + - | Scrolls forward or backward through the values or options of the highlighted field |
| Tabulator | Selects a field |
| F1 | Displays General Help |
| F2 | Load previous values |
| F3 | Load optimized default values |
| F4 | Saves and exits the setup program |
| Enter | Enters the highlighted submenu. When ► appears on the left of a particular field, it indicates that a submenu which contains additional options are available for that field. |

BIOS setup utility

- Main - Basic system configuration
- Advanced - Extended system configuration
- Chipset - Configuration chipset
- Boot - Boot sequence
- Security - Security settings
- Save and Exit - Save and exit

4.2 Main

The Main menu is the first screen that you will see when you enter the BIOS setup utility.

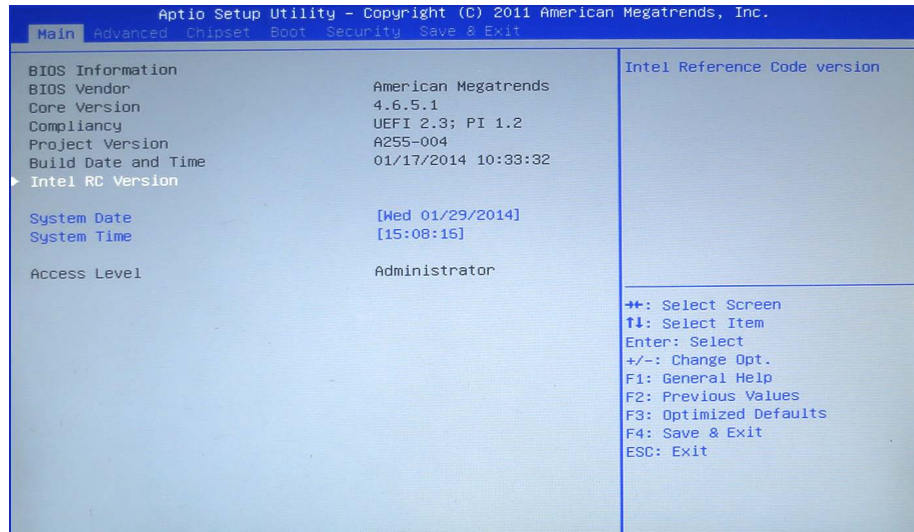

Intel RC Version Display the Intel Reference Code version.

System Date The date format is *day month/date/year* an.

- Day displays a day, from Monday to Sunday.
- Month displays the month, from January to December.
- Date displays the date, from 1 to 31.
- Year displays the year, from 1999 to 2099.

System Time The time format is *hour:minute:second*.

- hour displays hours from 00 to 23.
- minute displays minutes from 00 to 59.
- second displays seconds from 00 to 59.

Access Level Displays the access level of the current user in the BIOS (for example administrator).

4.3 Advanced

This menu allows you to configure the system's extended functions. Here you can configure the CPU and the periphery.



CAUTION! Setting incorrect field values may cause the system to malfunction.

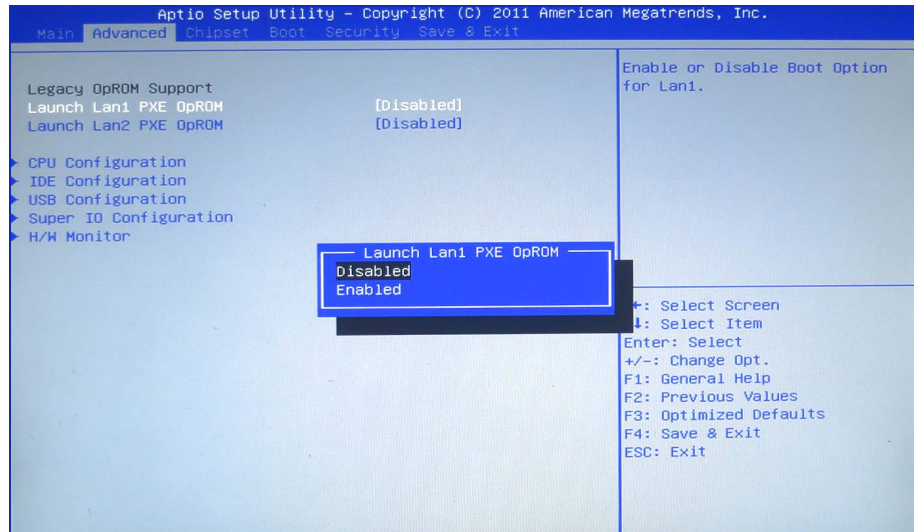

Launch LAN1/2 PXE OpROM

Enables or disables the boot option for legacy network devices connected to LAN1 or LAN2.

Disabled - Starts no PXE OpROM

Enabled - Starts the PXE OpROM, to be able to boot about PXE

Submenu "CPU Configuration"

This section is used to configure the CPU.

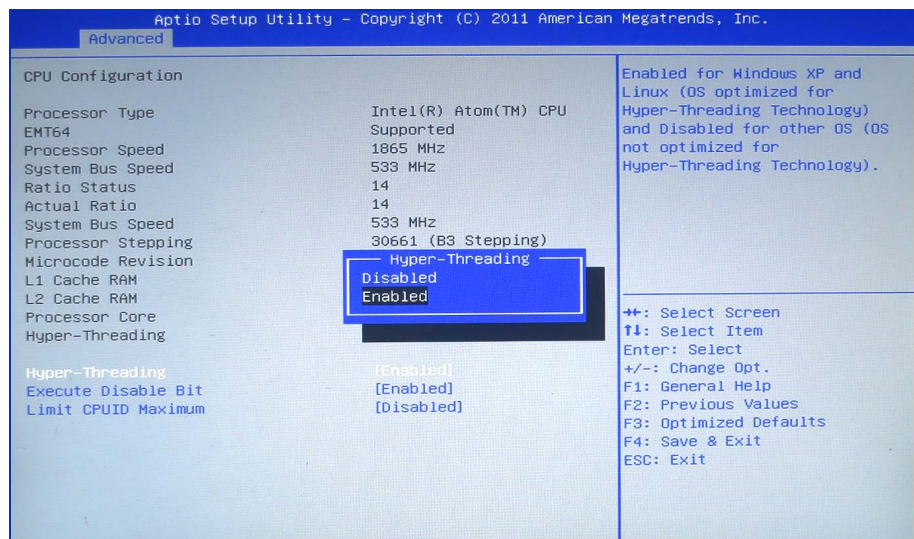

Hyper-Threading

This field is used to enable or disable hyper-threading.

Execute Disable Bit

XD can prevent certain classes of malicious buffer overflow attacks.

Enabled - Permit the switching on of the execute disable function by the OS.

Disabled - Prevents the switching on of the execute disable function by the OS; it will force the XD feature flag to always return to 0.

Limit CPUID Maximum

The CPUID instruction of some newer CPUs will return a value greater than 3. The default is disabled because this problem does not exist in the Windows series operating systems. If you are using an operating system other than Windows, this problem may occur. To avoid this problem, enable this field to limit the return value to 3 or less than 3.

Disabled - (default) All of the CPUID functions are supported.

Enabled - Limit the return value to 3 or less than 3.

Submenu "IDE Configuration"

This section is used to configure the IDE devices.

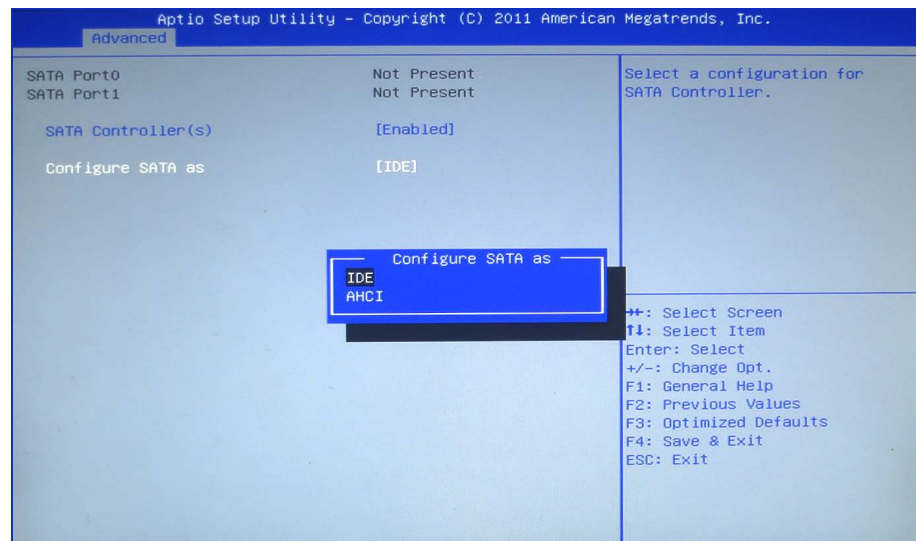

SATA Controller(s)

Enables or disables SATA controller.

Configure SATA as

Configures the SATA as IDE or AHCI mode.

IDE - This option configures the serial ATA drives as parallel ATA physical storage device.

AHCI - This option configures the serial ATA drives to use AHCI (AdvancedHost Controller Interface). AHCI allows the storage driver to enable the advanced serial ATA features which will increase storage performance.

Submenu "USB Configuration"

This section is used to configure USB devices, such as keyboard, mouse and hub.

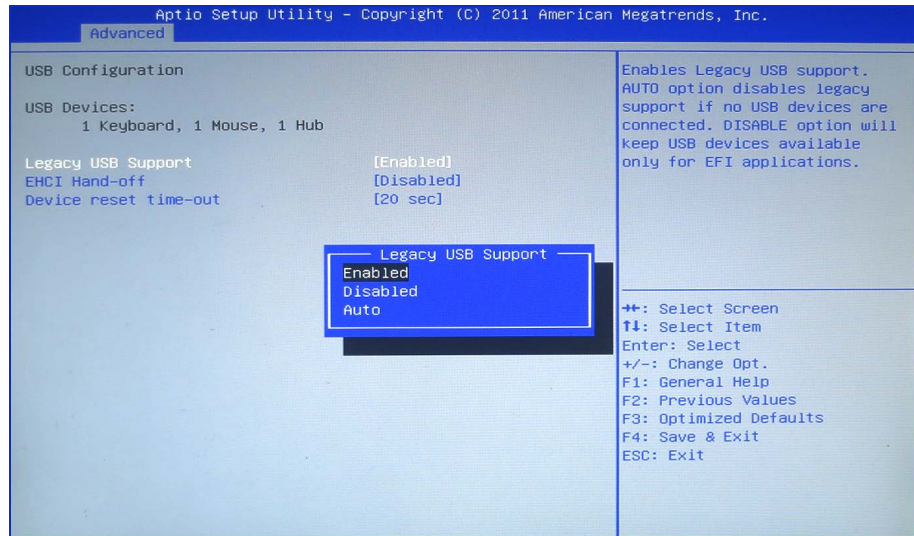

Legacy USB Support

Due to the limited space of the BIOS ROM, the support for legacy USB keyboard (in DOS mode) is by default set to disabled. With more BIOS ROM space available, it will be able to support more advanced features as well as provide compatibility to a wide variety of peripheral devices.

EHCI Hand-off

This is a workaround for OSs that does not support EHCI hand-off. The EHCI ownership change should be claimed by the EHCI driver.

Device reset time-out

Selects the USB mass storage device’s start unit command timeout (10, 20, 30 or 40 seconds).

Submenu "Super IO Configuration"

This section is used to configure serial ports 0 to 1.

Super IO Chip

Displays the Super I/O chip used on the board.

Submenu "Serial Port 0 Configuration"

This section is used to configure serial port 0.

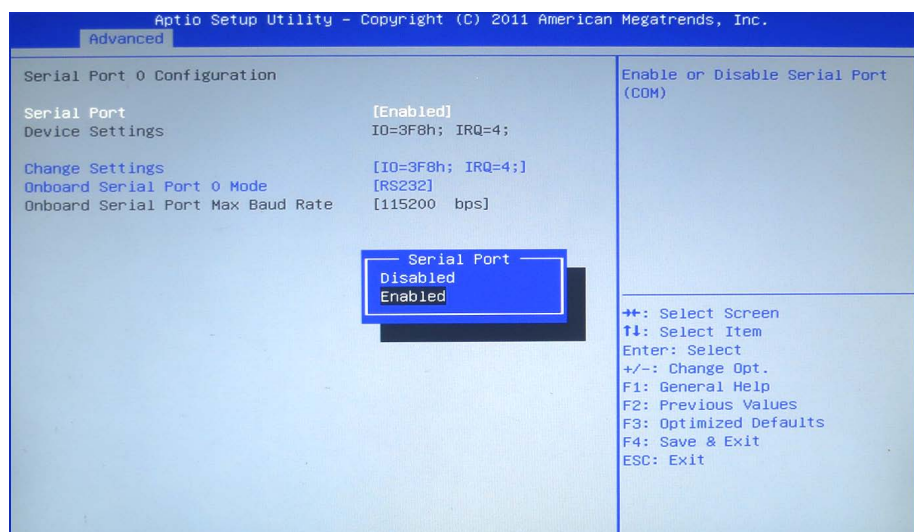

Advanced

Serial Port Enables or disables the serial port.
 Disabled - Serial port is not available
 Enabled - (default) Serial port is available

Change Settings Selects an optimal setting for the super IO device.

Onboard Serial Port 0 Mode This field is used to configure the mode of serial port 0 as RS232 (default), RS422, RS485 or RS485 AUTO.

Submenu "Serial Port 1 Configuration" This section is used to configure serial port 1.

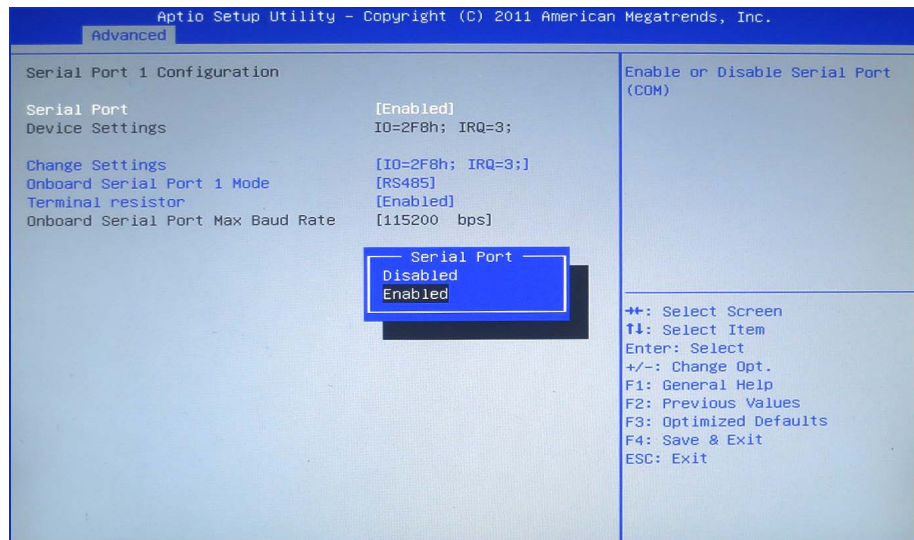

Serial Port Enables or disables the serial port.
 Disabled - Serial port is not available
 Enabled - (default) Serial port is available

Change Settings Selects an optimal setting for the super IO device.

Onboard Serial Port 1 Mode This field is used to configure the mode of serial port 1 as RS232, RS422 (default), RS485 or RS485 AUTO.

Terminal resistor Enables or disables the terminal resistor for RS422 and RS485.
 Disabled - Terminal resistor not activated
 Enabled - (default) Terminal resistor activated

H/W Monitor This section 'PC Health Status' is used to configure the hardware temperature and voltages.

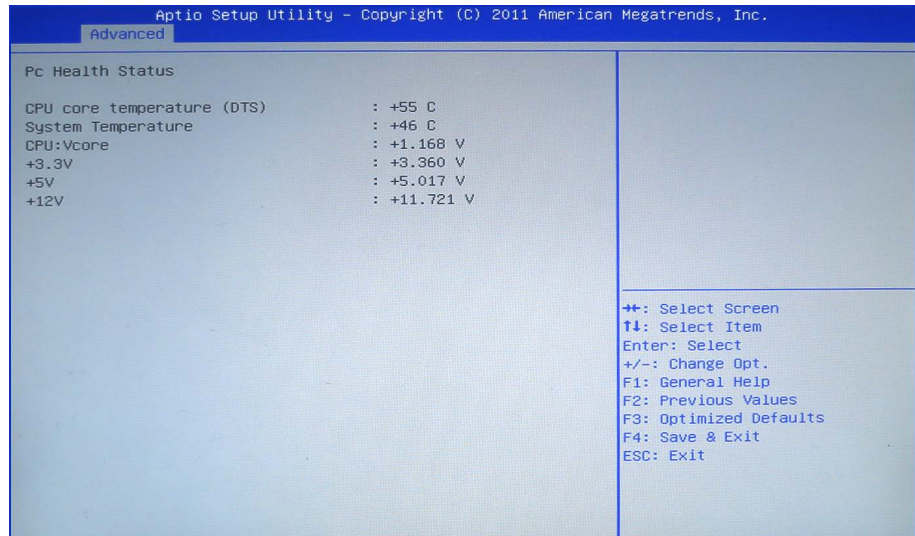

4.4 Chipset

This section is used to configure the system based on the specific features of the chipset.

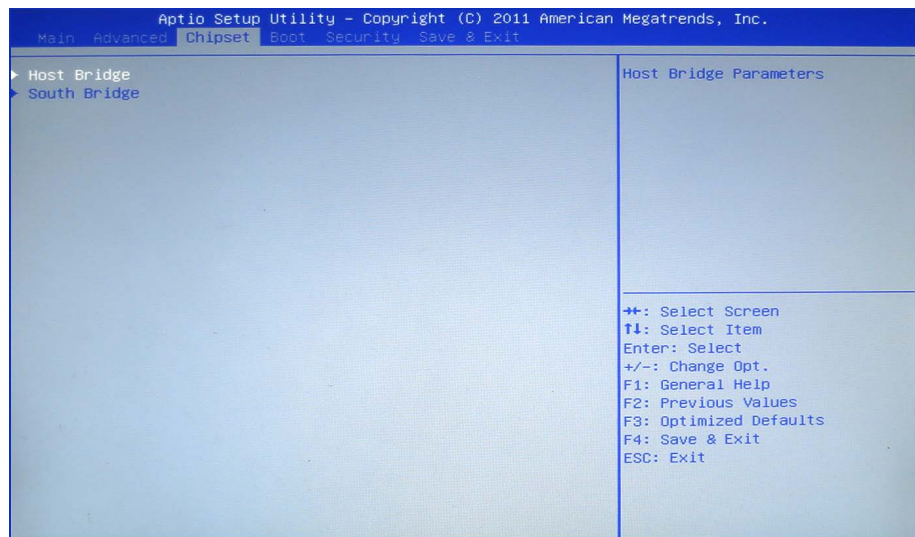

CAUTION!

Setting incorrect field values may cause the system to malfunction.

Host Bridge

Display the memory information.

Submenu "Intel® IGD Configuration"

This section is used to configure the Intel® IGD graphic configuration.

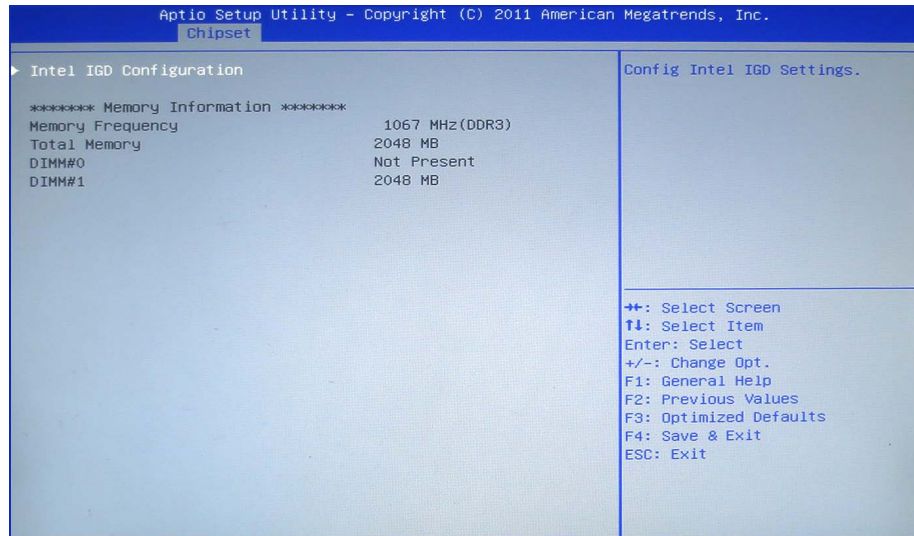

IGFX-Boot Type

This field is used to configure which video device will be activated during POST. This has no effect if external graphics present. The options are CRT, LVDS, DP-LVDS + CRT.

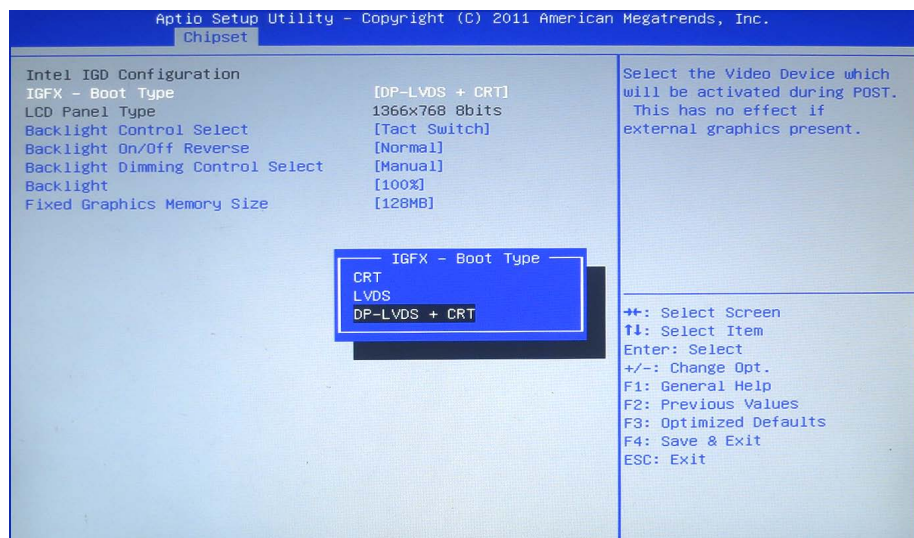

Backlight Control Select

The available options are 'Pyroelectric sensor' and 'Tact Switch'. The default setting is 'Tact Switch'.

Backlight On/Off Reverse

Please configure this option only when changing the panel, otherwise the display may not work.

Backlight Dimming Control Select

The options are 'Tact Switch', 'Manual' and 'Light Sensor'. The default setting is 'Manual' and the Backlight option below will be configurable.

Backlight

Adjust the brightness of the backlight.

Fixed Graphics Memory Size

This field is used to configure the memory size of the fixed graphics, the options are 128MB and 256MB.

Submenu "South Bridge"

This field is used to configure the south bridge chipset.

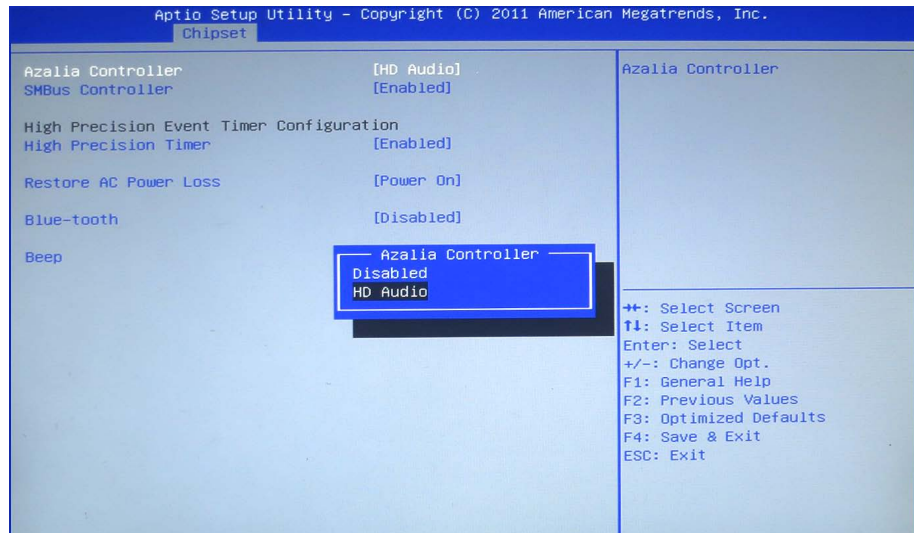

Azalia Controller

This section disables Azalia or enables HD Audio.

SMBus Controller

This section is used to disable or enable SMBus controller.

High Precision Timer

This section is used to configure high precision event timer.

Restore AC Power Loss

System response when power returns after an AC power failure.

Last State - The system will return to the state where you left off before power failure occurs.

Power Off - The system's power is off. You must press the power button to Power On the system.

Power On - (default) The system will automatically Power On.

Beep

Enables or disables 'Beep'.

4.5 Boot

This section is used to configure the boot features.

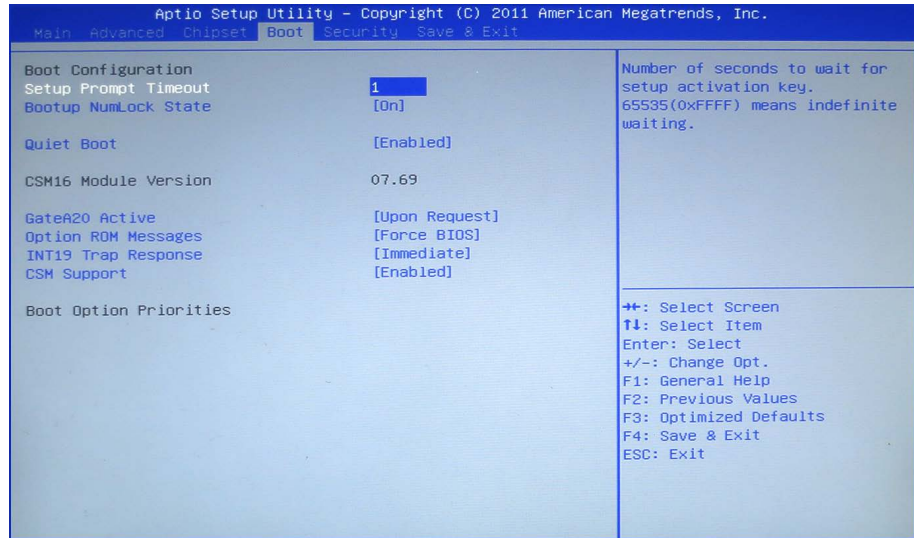

Setup Prompt Timeout

This section configures the number of seconds to wait for the setup activation key.

Bootup NumLock State

This allows you to determine the default state of the numeric keypad.
 On - (default) The function of the numeric keypad is the number keys.
 Off - The function of the numeric keypad is the arrow keys.

Quiet Boot

Enabled - (default) Displays OEM logo instead of the POST messages.
 Disabled - Displays normal POST messages.

GateA20 Active

Upon Request - GA20 can be disabled using BIOS services.
 Always - Do not allow disabling GA20; this option is useful when any RT code is executed above 1MB.

Option ROM Messages

This field is used to set display mode for Option ROM.

Int19 Trap Response

Allows Option ROMs to trap Interrupt 19 when enabled.

Boot Option Priorities

Adjust the boot sequence of the system.

Hard Drive BBS Priorities

Sets the order of the legacy devices in this group.

4.6 Security

If ONLY the Administrator's password is set

If only the Administrator's password is set, then this only limits access to setup and is only asked for when entering setup.

If ONLY the User's password is set

If only the User's password is set, then this is a power on password and must be entered to boot or enter setup. In Setup the user will have administrator rights.

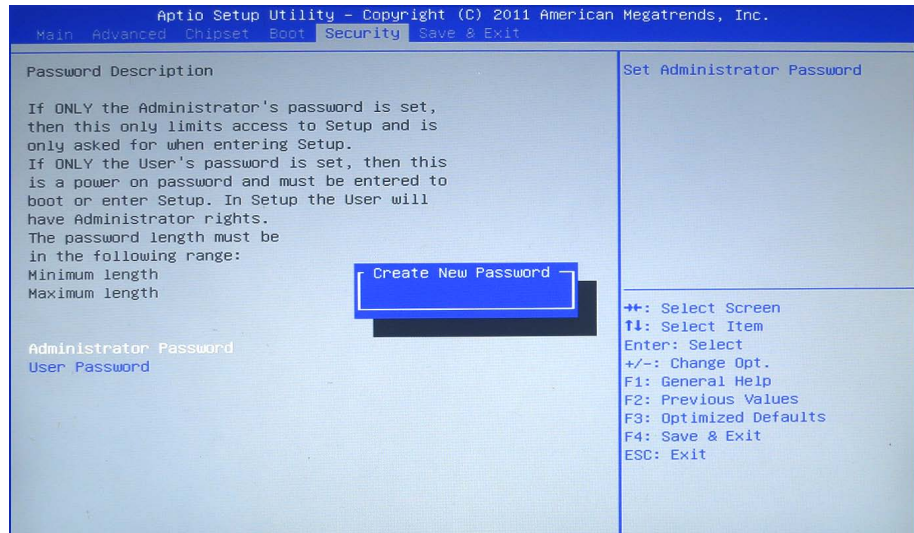

Administrator Password

Select this to reconfigure the administrator's password. Your password must contain at least 3 characters and should be maximal 20 characters long.

User Password

Select this to reconfigure the user's password. Your password must contain at least 3 characters and should be maximal 20 characters long.

4.7 Save and exit

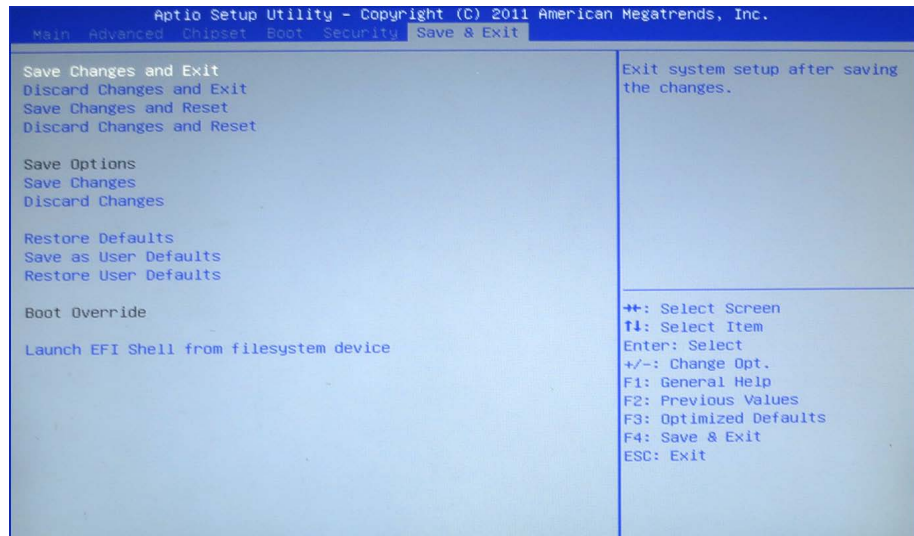

Save Changes and Exit

To save the changes and exit the setup utility, select this field then press *[Enter]*. A dialog box will appear. Confirm by selecting *[Yes]*. You can also press *[F4]* to save and exit setup.

Discard Changes and Exit

To exit the Setup utility without saving the changes, select this field then press *[Enter]*. You may be prompted to confirm again before exiting. The BIOS setup exits and the POST continued. You can also press *[Esc]* to exit without saving the changes.

Save Changes and Reset

To save the changes and reset, select this field then press *[Enter]*. A dialog box will appear. Confirm by selecting *[Yes]*. A restart follows and the new settings become effective.

Discard Changes and Reset

To exit the Setup utility and reboot the system without saving the changes, select this field then press *[Enter]*. You may be prompted to confirm again before exiting. The BIOS setup exits and a restart follows.

Save Changes

To save changes and continue configuring the BIOS, select this field then press *[Enter]*. A dialog box will appear. Confirm by selecting *[Yes]*.

Discard Changes

To discard the changes, select this field then press *[Enter]*. A dialog box will appear. Confirm by selecting *[Yes]* to discard all changes made and restore the previously saved settings.

Restore Defaults

To restore the BIOS to default settings, select this field then press *[Enter]*. A dialog box will appear. Confirm by selecting *[Yes]*.

| | |
|--|--|
| Save as User Defaults | To use the current configurations as user default settings for the BIOS, select this field then press <i>[Enter]</i> . A dialog box will appear. Confirm by selecting <i>[Yes]</i> . |
| Restore User Defaults | To restore the BIOS to user default settings, select this field then press <i>[Enter]</i> . A dialog box will appear. Confirm by selecting <i>[Yes]</i> . |
| Boot Override | To bypass the boot sequence from the boot option list and boot from a particular device, select the desired device and press <i>[Enter]</i> . |
| Launch EFI Shell from filesystem device | To launch EFI shell from a filesystem device, select this field and press <i>[Enter]</i> . |

5 Installation guidelines

5.1 Basic rules for the EMC-equitable assembly of installations

General

The installation guidelines contain information about the interference free deployment of a PLC system. There is the description of the ways, interference may occur in your PLC, how you can make sure the electromagnetic compatibility (EMC), and how you manage the isolation.

What does EMC mean?

Electromagnetic compatibility (EMC) means the ability of an electrical device, to function error free in an electromagnetic environment without being interfered respectively without interfering the environment.

The components of VIPA are developed for the deployment in industrial environments and meets high demands on the EMC. Nevertheless you should project an EMC planning before installing the components and take conceivable interference causes into account.

Possible interference causes

Electromagnetic interferences may interfere your control via different ways:

- Electromagnetic fields (RF coupling)
- Magnetic fields with power frequency
- Bus system
- Power supply
- Protected earth conductor

Depending on the spreading medium (lead bound or lead free) and the distance to the interference cause, interferences to your control occur by means of different coupling mechanisms.

There are:

- galvanic coupling
- capacitive coupling
- inductive coupling
- radiant coupling

Coupling mechanisms and interference sources

The following table shows the four different coupling mechanisms, their causes and possible interference sources.

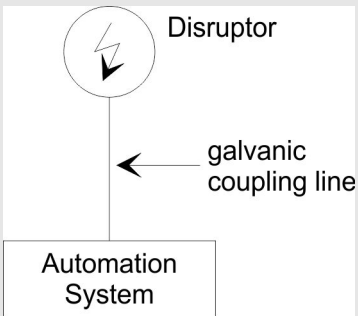
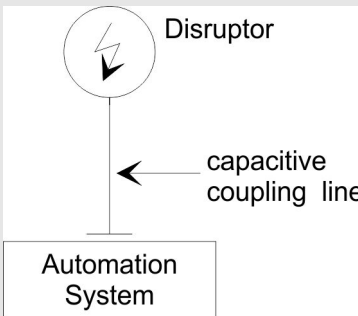
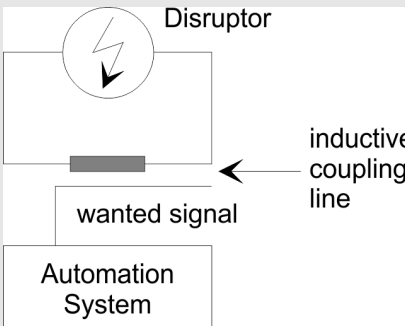
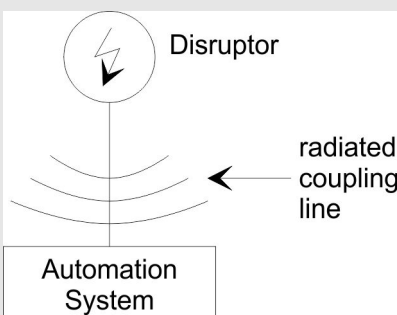
| Coupling mechanism | Cause | Typical source |
|--|--|---|
| <p>Galvanic coupling</p>  | Galvanic or metallic coupling always occurs, when two current circuits have a common line. | <ul style="list-style-type: none"> ■ Pulsed devices (Net influence from transducers and foreign net devices) ■ Starting motors ■ Different potential of component cubicles with common current supply ■ Static discharges |
| <p>Capacitate coupling</p>  | Capacitate or electric coupling occurs between conductors with different potential. The coupling is proportionate to the temporal change of the voltage. | <ul style="list-style-type: none"> ■ Interference through parallel signal lines ■ Static discharge of the personnel ■ Contactors |
| <p>Inductive coupling</p>  | Inductive or magnetic coupling occurs between two current active line loops. The magnetic flows associated with the currents induct interference voltages. The coupling is proportional to the time related change of the current. | <ul style="list-style-type: none"> ■ Transducers, motors, electric welding devices ■ Parallel net cables ■ Cables with toggled currents ■ Signal cable with high frequency ■ Unused coils |
| <p>Radiate power coupling</p>  | One talks of radiate power coupling, when an electromagnetic wave meets a line circuit. The hit of the wave inducts currents and voltages. | <ul style="list-style-type: none"> ■ Sender in the neighbourhood (e.g. walkie-talkie) ■ Sparking lines (sparking plugs, collector of electric motors, welding devices) |

Basic rules for EMC

In the most times it is enough to take care of some elementary rules to guarantee the EMC. Please regard the following basic rules when installing your PLC.

- Take care of a correct area-wide grounding of the inactive metal parts when installing your components.
 - Install a central connection between the ground and the protected earth conductor system.
 - Connect all inactive metal extensive and impedance-low.
 - Please try not to use aluminium parts. Aluminium is easily oxidizing and is therefore less suitable for grounding.
- When cabling, take care of the correct line routing.
 - Organize your cabling in line groups (high voltage, current supply, signal and data lines).
 - Always lay your high voltage lines and signal respectively data lines in separate channels or bundles.
 - Route the signal and data lines as near as possible beside ground areas (e.g. suspension bars, metal rails, tin cabinet).
- Proof the correct fixing of the lead isolation.
 - Data lines must be laid isolated.
 - Analog lines must be laid isolated. When transmitting signals with small amplitudes the one sided laying of the isolation may be favourable.
 - Lay the line isolation extensively on an isolation/protected earth conductor rail directly after the cabinet entry and fix the isolation with cable clamps.
 - Make sure that the isolation/protected earth conductor rail is connected impedance-low with the cabinet.
 - Use metallic or metallised plug cases for isolated data lines.
- In special use cases you should appoint special EMC actions.
 - Consider to wire all inductivities with erase links.
 - Please consider luminescent lamps can influence signal lines.
- Create a homogeneous reference potential and ground all electrical operating supplies when possible.
 - Please take care for the targeted employment of the grounding actions. The grounding of the PLC serves for protection and functionality activity.
 - Connect installation parts and cabinets with your PLC in star topology with the isolation/protected earth conductor system. So you avoid ground loops.
 - If there are potential differences between installation parts and cabinets, lay sufficiently dimensioned potential compensation lines.

5.2 EMC-equitable assembly

Mostly, measures for suppressing interference voltages are only taken, when the control is already in commission and the perfect receive of a wanted signal is disturbed. Causes for such interference's are in the most cases inadequate reference potentials, coming from mistakes at the device assembly and installation.

Guidelines for assembling and grounding of inactive metal parts

When assembling the devices, you have to ensure the large-surface grounding of the inactive metal parts. A correctly done grounding supports an unambiguous reference potential for the control and reduces the impact of coupled interferences.

Grounding means the conducting connection of all inactive metal parts. The sum of all interconnected inactive parts is called ground.

Inactive parts are all conductive parts electrically separated from all active parts by means of a basic isolation and that may only get voltage in case of an error.

The ground must not adopt dangerous contact voltage even in case of an error. Thus you have to connect the ground with the protected earth conductor. To avoid ground loops, local distant ground constructions (cubicles, construction and machine parts) have to be connected with the protected earth conductor system in star-topology.

Please regard at grounding:

- Connect the inactive metal parts as carefully as the active ones.
- Take care of impedance-low metal-metal-connections, e.g. with large-surface and well conductive contacts.
- If you include coated or anodized metal parts in the grounding, you have to come through the isolating protection layers. For this you may use special contact washers or remove the isolation layer.
- Protect the connection points from corrosion, e.g. with grease.
- Moveable grounding parts (e.g. cubicle doors) have to be connected via flexible ground strips. The ground strips should be short and have a large surface, because the surface is decisive for the diversion of high frequency interferences.

5.3 EMC-equitable cabling

Line routing

Content of this section is the line routing of bus, signal and supply lines. Object of the line routing is to suppress the "slurring" at parallel lines.

Line routing inside and outside of cubicles

For an EMC-equitable routing of the lines it is convenient to divide the cables in different groups and install each group itself:

Group A

- screened bus and data lines
- screened analog lines
- unshielded lines for direct voltage $\leq 60V$
- unshielded lines for alternating voltage $\leq 25V$
- Coaxial cables for monitors

Group B

- unshielded lines for direct voltage $> 60V$ and $\leq 400V$
- unshielded lines for alternating voltage $> 25V$ and $\leq 400V$

Group C

- unshielded lines for direct and alternating voltage $> 400V$

Group D

- Lines for H1 respectively TCP/IP

Combination of groups

Following the table you may see the conditions for the cabling of the line groups by combining the single groups:

| | Group A | Group B | Group C | Group D |
|---------|---------|---------|---------|---------|
| Group A | [1] | [2] | [3] | [4] |
| Group B | [2] | [1] | [3] | [4] |
| Group C | [3] | [3] | [1] | [4] |
| Group D | [4] | [4] | [4] | [1] |

- [1] The lines may be installed in common bundles or cable trusses.
- [2] The lines have to be installed in different bundles or cable trusses (without min. distance).
- [3] The lines have to be installed in different bundles or cable trusses inside of cubicles and outside of the cubicle but inside the building in separated cable trusses with a min. distance of 10cm.
- [4] The lines have to be installed in different bundles or cable trusses with a min. distance of 50cm.

Line routing outside of buildings

Wherever possible, exterior cabling should be installed on metallic cable trays. A galvanic connection must be provided for joints between cable trays. You must abide by the applicable lightning protection and grounding regulations when installing exterior cables.

Lightning protection



CAUTION! Where cables and signal lines for PLC equipment are installed outside of buildings, the conditions for internal and external lightning protection must be satisfied.

- Exterior lines should either be installed in metallic conduit pipes that is grounded on both ends or in steel-reinforced concrete cable trunks with continuously connected reinforcing.
- Signal lines should be protected against overvoltage by varistors or by lightning arrester filled with rare gas.
- Install these protective elements at the location where the cables enter the building.



Any lightning protection system must be based on an individual assessment of the entire plant. For questions please contact VIPA GmbH.

- Equipotential bonding** Potential differences can occur between different sections when controllers and peripheral equipment are connected by means of non-isolated connections or the screens of screened cables are connected at both ends and grounded on different sections of the plant. One reason for a potential difference can be that different sections of the plant are powered from different power sources. These potential differences must be reduced by means of equipotential bonding conductors to ensure that the electronic equipment employed on the plant operates properly.
- Rules for equipotential bonding**
- The lower the impedance of the equipotential bonding conductor, the higher the effectiveness of potential equalization.
 - The impedance of the equipotential bonding conductor must not exceed 10% of the impedance of the screen where screened signal lines are connected between the different sections of the plant and the screening is connected to ground/neutral on both sides.
 - The cross-sectional area of the equipotential bonding conductor must be calculated to carry the maximum equalization current. The following cross-sections have been successfully employed:
 - 16mm² Cu for equipotential bonding conductors up to 200m
 - 25mm² Cu equipotential bonding conductors exceeding 200m.
 - Use copper or galvanized steel for equipotential bonding conductors. These must be connected to ground/neutral by means of large-surface connections that are protected from corrosion.
 - The equipotential bonding conductor should be installed in such a manner that it includes the smallest surface between the bonding conductor and the signal lines.
- Screening of lines and cables** Screening is one method commonly used to reduce (attenuate) the interference pick-up from magnetic, electrical or electromagnetic fields.
- Interference on screens is conducted to ground by the conductive connection between the screen and the screening rain/enclosure. To avoid interference from these currents it is very important that the neutral connection is a low-impedance connection.
 - You should only use cables that are provided with a braided screen. The degree of screening should be more than 80%.
 - Avoid cables with foil-type screens as the foil can be easily damaged by tension and pressure at the point of attachment; this can result in reduced effectiveness of the screening action.
 - As a rule you should always ground the screens of cables on both ends. This is the only way in which you can ensure that high frequency interference is attenuated properly.
- One-sided grounding of screens** In exceptional cases it may be necessary to ground the screen on one side only. However, this will only attenuate the lowest frequencies. The one-sided grounding of screens may provide advantages when:
- It is not possible to install an equipotential bonding conductor
 - Analogue signals (a few mV or mA) must be transmitted
 - Foil-type screening (static screening) is employed.

You should always use metallic or metallised covers for serial data lines. Connect the screen of the data line to the cover. Do **not** connect the screen to PIN 1 of the connector! In case of stationary operations it is recommended that the remove the insulation from the screened cable without cutting the screen and to attach this point to the screening/neutral rail.



Potential differences can give rise to an equalization current via the screen connected between the two ground connections. In this case you must install an additional equipotential bonding conductor.

Connecting the screen

Please observe the following points when you handle the screens:

- Use only metallic cable clamps when connecting the screening of cables. These clamps must provide a good electrical contact and a large-surface connection to the screen.
- Attach the screens to the screening rail directly at the point where the cables enter the enclosure. The screening conductor must be continued to the module without interruption, however, it must not be connected to the module!

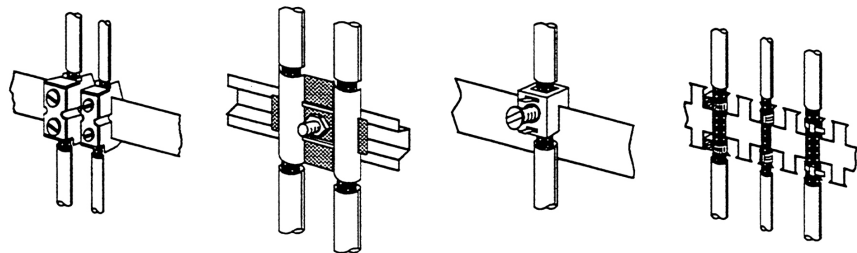

5.4 Special precautions providing high noise immunity

Inductors require snubber networks

Inductors controlled by your programmable controller (e.g. contactors and relays) do not normally require additional snubber networks or suppressors as the respective modules have been provided with the required components.

Equipotential bonding

Snubber networks must only be connected to inductors when output circuits can be disabled by means of additional contacts (e.g. relay contacts). In this case the integrated suppressors on the module are also disabled. You can connect diodes to suppress back-emc, varistors or RC-networks to the inductors.

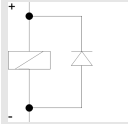
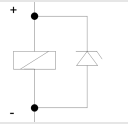
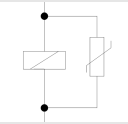
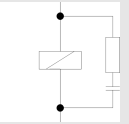
| Connections of DC-activated inductors | | Connections of AC-activated inductors | |
|---|---|---|--|
| using a diode | using a Z-diode | using a varistor | using RC-network |
|  |  |  |  |

Power outlet for PGs

Every cubicle must be provided with a power outlet for the PU. These outlets must be wired to the distribution system, which is also used to connect the neutral conductor for the cubicle.

Cubicle illumination

The cubicle illumination should consist of incandescent lights, e.g. LINESTRA-lamps. Avoid using fluorescent lamps as these lamps can cause interference. If you can not avoid using fluorescent lamps you should implement the steps outlined in the following figure.

Suppression of fluorescent lamps in cubicles

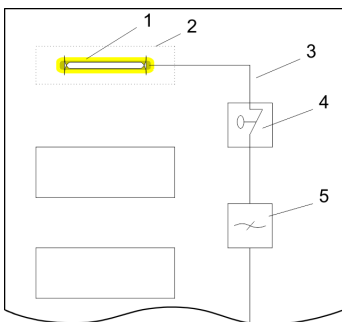

- 1 Fluorescent lamp
- 2 Screen above the lamp
- 3 Screened cable
- 4 Switch with metallic cover
- 5 Line filter or screened power cable

5.5 Checklist for the EMC-compliant installation of controllers

| EMV-measures | Space for Notes |
|--|-----------------|
| Connection of the inactive parts | |
| You should take special care to check the connections of: | |
| <ul style="list-style-type: none"> ■ Module racks ■ Frames ■ Screen and protected earth conductor | |
| Are all the inactive metal parts interconnected by means of large-surface and low-impedance connections? | |
| Has a proper connection been installed with respect to the ground/protected earth conductor system? | |
| Has the isolation been removed from varnished and anodized surfaces or have these connections been fitted with special contact washer? | |
| Have the connection been protected from corrosion, e.g. by means of grease? | |
| Have doors been grounded by means of grounding straps connected to the body of the cubicle? | |
| Cable routing | |
| Cabling divided into groups? | |
| Power cables (230 ... 400V) and signal lines installed in separate channels or bunches? | |
| Potential compensating | |
| When installing the equipment at separate locations, check the installation of the potential compensating line. | |
| Cable screen | |
| All covers of plugs are metallic? | |
| All analog and data lines installed screened? | |
| Line screens attached to the screening or the protected earth conductor? | |
| Have the screens been connected by means of large-surface and low-impedance cable clamps? | |
| Cable screens grounded both-sided where possible? | |
| Inductors | |
| Have the coils of contactors controlled by means of contacts been connected to snubber networks? | |