

VIPA FM355 / R355

4-/8-Channel Control Module for Siemens S7-300 and VIPA System 300V

3-349-328-03
15/10.09



1	Initial Start-Up	5
1.1	Safety Precautions	5
1.2	Installing the Controller	5
1.3	Operating the Controller via Interface	5
2	Controller Settings	6
2.1	Basic Configuration as 2 or 3-Step Fixed Setpoint Controller	6
2.1.1	Behaviour of the Module when CPU in Stop	6
2.1.2	Configuring the Temperature Measurement Inputs	6
2.1.3	Configuring the Control Channels	6
2.1.4	Configuring the Actuating Outputs	7
2.2	Configuration of Controller Outputs and Actuators	7
2.2.1	2-Step, 3-Step Controllers, Continuous-Action Controllers, Step-Action Controllers	7
2.2.2	Water Cooling	8
2.2.3	Hot-Runner Controller	8
2.2.4	Controlling Contactors	8
2.2.5	Power Limitation	8
2.3	Processing Setpoints and Actual Values	9
2.3.1	Setpoint Ramps, Proxy Setpoint, Setpoint Limiting	9
2.3.2	External Actual Value	9
2.3.3	Adaptive Measured Value Correction for Ascertaining the Actual Value	9
2.3.4	Suppression of Periodic Disturbances	10
2.3.5	Actual Value Correction for Temperature Sensors	10
2.3.6	Scaling the 10 V / 20 mA Inputs	11
2.3.7	Using the Thermocouple Input As Linear Input	12
2.4	Configuring Control Response	13
2.4.1	Controller Type	13
2.4.2	Controller Classes	13
2.5	Regulating the Control Functions	15
2.5.1	Assignment to Groups	15
2.5.2	Setting Controller Functions via Binary Input	15
2.5.3	Manual Operation / Controller Off	15
2.5.4	Feed-Forward Control	16
2.6	Hot-runner Control	16
2.6.1	Actuating Circuit	16
2.6.2	Temporary Setpoint Rise (Boost)	16
2.6.3	Actual Value Control, Synchronous Heat-Up	17
2.7	Determining Controller Parameters	18
2.7.1	Self-Optimization (self-tuning)	18
2.7.2	Manual Optimization	19
2.8	Monitoring Functions	21
2.8.1	Overview of Channel-Specific Alarms	21
2.8.2	Overview of Device-Specific Alarms	21
2.8.3	Limit Value Monitoring	22
2.8.4	Limiter	22
2.8.5	Heating Circuit Monitoring	22
2.8.6	Heating Current Monitoring	23
2.8.7	Performance in the Event of Sensor Error	24
2.8.8	Monitoring the Binary Outputs	25
2.8.9	Device Errors	25
2.8.10	Clearing Error Bits	25
2.8.11	Read-Out of Channel-Specific Alarms	25
2.8.12	Read-Out of Group Alarms or Self-Optimization Active Status	25
2.9	Special Functions	26
2.9.1	Control of Continuous Outputs	26
2.9.2	Data Logger	26
2.9.3	Checking Sensor and Heater Assignments (mapping)	27
2.9.4	Alarm History	28
2.10	Parameter Sets	28

3	RS 232 Service Interface with Protocol per EN 60870	31
3.1	General	31
3.1.1	Interface Configuration	31
3.1.2	Communication Protocol	31
3.1.3	Primary Function	31
3.1.4	Time Response	31
3.2	Frame Types and Layout	32
3.2.1	Short Strings	32
3.2.2	Control Strings	32
3.2.3	Long String	32
3.2.4	Format Character Function and Value Range	33
3.2.5	Criteria for the Validity of a Query Frame	34
3.3	Frame Contents	35
3.3.1	Reset Device	35
3.3.2	Query: Device OK?	35
3.3.3	Cycle Data	36
3.3.4	Heating Current Data	36
3.3.5	Events Data	37
3.3.6	Requesting Data from the Controller	38
3.3.7	Transmitting Data to the Controller	39
4	Communication via Backplane Bus	41
4.1	General	41
4.2	Exchange of Binary I/O Data	41
4.3	Exchange of Measured Values, Parameters and Configurations	42
4.3.1	Function Field	43
4.3.2	Block Number	43
4.3.3	Checksum	43
4.3.4	Data Block Format	43
4.3.5	Pre-defined Blocks	44
4.3.6	Transmission of Parameter Sets	49
5	Device Parameters	51
5.1	Overview	51
5.2	Main Group 0: Temperature Parameters	53
5.2.1	Table of Parameter Indices	53
5.2.2	Unit of Measure and Setting Range	53
5.3	Main Group 1: Control Parameters	54
5.3.1	Table of Parameter Indices	54
5.4	Main Group 2: Control Commands	54
5.4.1	Table of Parameter Indices	54
5.4.2	Controller Function	54
5.4.3	Error Status	55
5.4.4	Controller Configuration	56
5.4.5	Extended Controller Configuration	56
5.4.6	Controller Status, Message Word	56
5.4.7	Channel Error Mask	57
5.4.8	Group Error Mask	57
5.4.9	Alarm History	57
5.5	Main Group 3: Device Specification	58
5.5.1	Table of Parameter Indices	58
5.5.2	Device Features	58
5.5.3	Device Control	58
5.5.4	Limit Value Function and Heating Circuit Monitoring	58
5.5.5	Output Configuration	59
5.5.6	Parameter Set ID	59
5.6	Main Group 6: Heating Current Monitoring	60
5.6.1	Table of Parameter Indices	60
5.7	Main Group 9: Data Logger	60
5.7.1	Table of Parameter Indices	60

Contents		Page
5.8	Main Group B: Display Values	60
5.8.1	Table of Parameter Indices	60
5.9	Main Group E: Control Functions	60
6	Index	62
7	Parameter Index	64
8	Repair and Replacement Parts Service and Rental Instrument Service	66
9	Product Support	66

1 Initial Start-Up

Read the operating instructions completely and carefully before using the device, and follow all instructions included therein.



Note

Parameter designations are printed in boldface, and *setting values* are printed in cursive typeface in these operating instructions.

The operating instructions should be made available to all users.

1.1 Safety Precautions

The instrument is manufactured and tested in accordance with safety regulations IEC 61010-1 / EN 61010-1 / VDE 0411 part 1. If used for its intended purpose, safety of the user and of the device is assured.



Attention!

Check the specified nominal voltage at the front housing panel before placing the instrument into service. When wiring the instrument, make sure the connector cables are not damaged, and that they are voltage-free. If it can be assumed that safe operation is no longer possible, the instrument must be immediately removed from service (disconnect auxiliary voltage!). Safe operation can no longer be relied upon if the instrument demonstrates visible damage. The device may not be placed back into operation until troubleshooting, repair and subsequent testing have been performed at our factory, or at one of our authorized service centers. Work on live open instruments may only be carried out by trained personnel who are familiar with the dangers involved. Capacitors inside the instrument may be dangerously charged, even if it has been disconnected from all power sources.

Requirements set forth in VDE 0100 must be observed during the performance of all work.

1.2 Installing the Controller

The instrument must be installed in accordance with separate installation instructions.

Make sure that all relevant criteria have been observed during assembly, preparation, installation, electrical connection and initial start-up by means of identification based upon article number and feature codes.

1.3 Operating the Controller via Interface

Service interface

Independent of the bus interface, the controller is equipped with an RS 232 service interface with protocol per EN 60870 (see chapter 3 on page 31), which allows for communication with each individual instrument.

R355CONFIG PC software is available for this purpose. It can be downloaded free of charge from the GMC-Instruments Deutschland GmbH website at: <http://www.gossenmetrawatt.com>

R355CONFIG PC software

All parameters can be conveniently accessed with R355CONFIG PC software, parameter sets can be saved to memory at the PC, and existing parameter sets can be uploaded to controller. Current measured values (cycle data) can be displayed.

Please read chapter 2 as from page 6 first, for a thorough understanding of R355CONFIG PC software and the controller.

System requirements:

- IBM PC or compatible with Pentium 300 MHz processor or higher
- Windows 95, 98, NT 4.0 or 2000
- 64 MB RAM for Windows 95 or 98, 128 MB RAM for Windows NT 4.0 / 2000 / XP
- Approximately 5 MB available hard disk space

A separate operating manual for this software is available on the GMC-I Messtechnik GmbH homepage.

2.1.4 Configuring the Actuating Outputs

All binary inputs and outputs and the continuous outputs can be freely assigned to actuating signals and other entry and display functions.

Attention: Configuration must be executed in the same way for the variant without I/Os, because the periphery bits replace the hardware I/Os.

A controller channel can be set up as a 2-step controller by configuring one binary output as a heating output with the corresponding channel number.

A 3-step controller is created when, in addition to the heating output, another binary output is configured as a cooling output with the corresponding channel number.

The 8 bits included in the **output configuration** have the following significance in the case of a binary actuating output:

Bit Number	Value	Meaning
0	0	Configuration as output
1	1	Single channel
2 ... 4	0 ... 7	Channel number
5	0 / 1	Heating / cooling
6	0	Mode
7	0	Actuating signal

The **output configuration** for unused outputs should be set to 0.

Upon shipment from the factory, binary outputs 1 through 8 are set up as heating outputs for channels 1 through 8 in their **output configurations**, and binary outputs 9 through 16 are set up as cooling outputs, which means that all 8 channels are configured as discontinuous-action 3-step controllers.

2.2 Configuration of Controller Outputs and Actuators

2.2.1 2-Step, 3-Step Controllers, Continuous-Action Controllers, Step-Action Controllers

Various actuators for the heating and cooling functions can be freely combined per controller channel.

The controller's output function, i.e. 2-step, 3-step, continuous-action, step-action or combinations thereof, is defined by assigning an **output configuration** to the outputs.

Bit Number	Value	Meaning for Discontinuous-Action Output	Meaning for Continuous-Action Output
0	0	Configuration as output	
1	1	Single channel	
2 ... 4	0 ... 7	Channel number	
5	0 / 1	Heating / cooling	
6	0 / 1	More / less	Dead / live zero
7	0	Actuating signal	

Bits 5 and 6 define the actuator in the **output configuration**.

Heating Actuator	Configuration of 1 st Heating Output	Configuration of 2 nd Heating Output
No heating actuator	—	—
SSR, contactor for discontinuous control	Binary output bit 5 = "heating" = 0 bit 6 = "more" = 0	—
(continuous) Proportional actuator	Continuous output bit 5 = "heating" = 0	—
Motor actuator for step-action control	Binary output bit 5 = "heating" = 0 bit 6 = "more" = 0	Binary output bit 5 = "heating" = 0 bit 6 = "less" = 1

Cooling Actuator	Configuration of 1 st Cooling Output	Configuration of 2 nd Cooling Output
No cooling actuator	—	—
SSR, contactor for discontinuous control	Binary output bit 5 = "cooling" = 1 bit 6 = "more" = 0	—
(continuous) Proportional actuator	Continuous output bit 5 = "cooling" = 1	—
Motor actuator for step-action control	Binary output bit 5 = "cooling" = 1 bit 6 = "more" = 0	Binary output bit 5 = "cooling" = 1 bit 6 = "less" = 1

- Actuators for heating and cooling are selected independent of each other (this allows for the combination of, for example, step-action control for heating, as well as for cooling.)
- If 2-step control is required, heating and cooling outputs may not be configured simultaneously for the respective channel.
- Several outputs of the same type can be assigned to the same controller output for separate control of several actuators with a single controller output.
- If continuous and discontinuous outputs are configured simultaneously for heating (or cooling), the channel functions as a continuous-action controller, and the step-action outputs are disabled.
- If only a "less" output is inadvertently configured for heating (or cooling), it remains inactive.
- Settings for **controller class** and **controller type** can be freely combined.

2.2.2 Water Cooling

If the **water cooling** bit is set in the **controller configuration**, the cooling manipulated variable is read out in a modified fashion, in order to account for the disproportionately powerful cooling effect which prevails when water is evaporated.

2.2.3 Hot-Runner Controller

If the **hot-runner** bit is set in the **controller configuration**, the heating manipulated variable is read out as a rapidly pulsating signal. This assures that localized overheating is avoided at hygroscopic cartridge heaters during actuation, and prevents temperature fluctuation within the heaters. Further functions which are dependent upon this setting are described in a separate chapter, namely chapter 2.6 on page 16.

2.2.4 Controlling Contactors

If, during ascertainment of control parameters (manual optimization or self-tuning), a **cycle time** results which is significantly shorter than advisable for the service life of the contactor, **cycle time** can be increased all the way up to the limit of system controllability by setting the **contactor** bit in the **extended controller configuration** (PI = 23h). If the bit is set before self-tuning is started, cycle time is set to the highest possible value by the self-tuning function.

2.2.5 Power Limitation

If, for reasons of current loading, it is not permissible or reasonable to have the heaters of all eight control circuits activated simultaneously, the controller can be forced with the **power limitation** (PI = 3Ah) parameter to actuate only a predefined number of heating outputs per device at the same time.

For example, if a maximum of only 5 heaters may be activated at the same time, the power limitation is set to 62% (approx. 5/8). This function is cancelled by entering 0%.

The manipulated variables of the channels with a configured heating output are automatically limited by the controller in accordance with power limitation. The positioning output of the individual channels is synchronized and the heaters are activated with in a staggered pattern.

The actual currents applied (if they were known from heating current monitoring) are not taken into account in this context.

This function is also active when power limitation has been set to 100% so that all eight channels produce full heat during actuation. However, current loading is more evenly spread at the operating point, thus avoiding power peaks.

If self-tuning is launched during active power limitation (see chapter 2.7.1 on page 18), the **actuation cycle time** is not established by the self-tuning function.

It is therefore necessary to adjust a reasonable actuation cycle time for those control loops involved in power limitation or to effect the self-tuning without power limitation.

2.3 Processing Setpoints and Actual Values

2.3.1 Setpoint Ramps, Proxy Setpoint, Setpoint Limiting

- The setpoint ramp is activated when:
 - Auxiliary voltage is switched on / after reset
 - When the setpoint is changed / the proxy setpoint is activated
 - Upon switching from the off state or manual operation to automatic operation
- Setpoint ramps are inactive during self-optimization.
- Relative limit values make reference to the targeted setpoint, not the ramp.
- Corresponding bits are set in **controller status** when setpoint ramps are active.

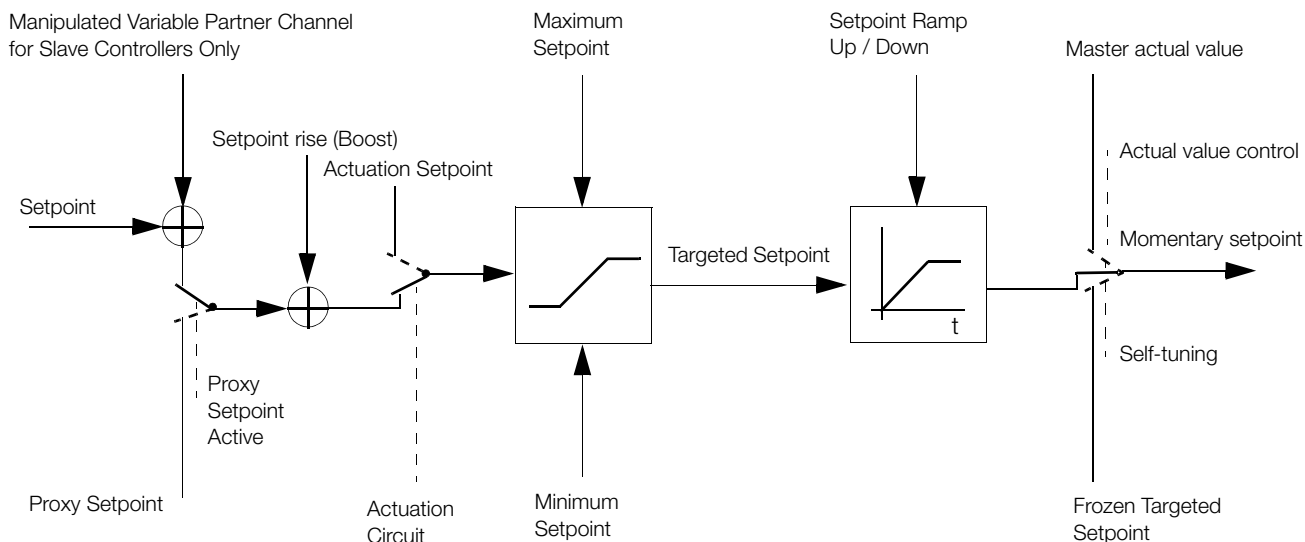

Figure 1 Setpoint Processing Schematic

2.3.2 External Actual Value

If the **external actual value** bit is set in the **extended controller configuration** (PI = 23h), the **external actual value** (PI = 27h) read in via the interface is used instead of the actual value measured by the instrument. Scaling or correction by means of **actual value factor** and **actual value correction** is not possible in this case.

2.3.3 Adaptive Measured Value Correction for Ascertaining the Actual Value

If a control loop is impaired by a periodic interference signal effecting the actual value, control can be improved by activating adaptive measured value correction. Periodic interference is thus suppressed without reducing the controller's ability to respond to system deviation. This is accomplished by adaptively adjusting correction to the oscillation amplitude of the interference signal, and by transmitting only the mean value to the controller.

Bit 14 in the **controller configuration** activates adaptive measured value correction.

Adaptation of the correction to the interference is executed in accordance with controller dynamics, and does not required any other parameters.

Control can only be **improved** if:

- The oscillation amplitude of the interference signal is constant, or changes slowly
- The oscillation period is shorter than half of system delay (compare: PI = 14h)

Due to the fact that this correction greatly influences actual value determination, control may also be **worsened**, for example if:

- Measured value deviation is irregular
- Isolated measured value outliers occur
- Fluctuation is not periodic
- The interference signal is random

2.3.4 Suppression of Periodic Disturbances

If the measured value is superimposed by a heavy periodic oscillation, which is caused, for example, by cyclical withdrawal of energy from the control circuit, the manipulated variable may fluctuate between its extremes and the control result may be unsatisfactory.

When the period is constant, the oscillation can be filtered out by adjusting the period in the **oscillation hold-off** (PI = 25h) parameter. This is done by filtering out the signal component within a narrow band with the adjusted period and by deducting it from the measuring signal for the control action. This leaves the actual display values unaffected.

In contrast to the adaptive measured value correction (see chapter 2.3.3) you can also suppress oscillations with periods longer than half of system delay.

Periods from 0.3 to 25 sec. can be adjusted. The filter remains inactive when other values are adjusted (0 sec. to 0.2 sec. or more than 25 sec.).

Since the hold-off filter influences controller dynamics, it is necessary to determine the control parameters by manual or self-optimization with the oscillation hold-off activated.

2.3.5 Actual Value Correction for Temperature Sensors

If a temperature sensor has been directly connected (i.e. if **sensor type** has not been set to *linear*), both the **actual value correction** and the **actual value factor** parameters can be used to compensate for deviations between measured temperature and the temperature value to be displayed.

The **actual value factor** changes temperature in proportion to the measured value. No change takes place with an **actual value factor** of 100.0% (default setting).

The value selected for the **actual value correction** parameter is added to the measured temperature value (and may also be changed by means of the actual value factor). Excessively large measured values obtained from resistance thermometers and with 2-wire connections are thus corrected.

Two measuring points are required for calculating the parameter setting (the measured value corresponds to temperature prior to correction, and the display value corresponds to temperature after correction):

$$\text{Actual value factor} = \frac{\text{display value 1} - \text{display value 2}}{\text{meas. value 1} - \text{meas. value 2}} \cdot 100\%$$

$$\text{Actual value correction} = \text{display value} - \frac{\text{meas. value} \cdot \text{actual value factor}}{100\%} \quad \text{where unit of measure} = \text{°C}$$

$$\text{Actual value correction} = (\text{display value} - 32.0\text{° F}) - \frac{(\text{meas. value} - 32\text{° F}) \cdot \text{actual val. corr.}}{100\%} \quad \text{where unit of measure} = \text{°F}$$

Example:

A temperature drop occurs between a tool heater and the surface of the tool. The measured temperature value (at the heater) is 375° C (measured value 1), and the temperature at the surface of the tool (temperature to be displayed) is 245° C (display value 1). The measured value should not be changed at room temperature (i.e. with tool heater switched off).

(Measured value 2 = display value 2 = 23.0° C.)

Solution:

$$\text{Actual value factor} = \frac{245\text{° C} - 23\text{° C}}{375\text{° C} - 23\text{° C}} \cdot 100\% = 63.1\%$$

$$\text{Actual value correction} = 23\text{° C} - \frac{23\text{° C} \cdot 63.1\%}{100\%} = 8.5\text{° C}$$

2.3.6 Scaling the 10 V / 20 mA Inputs

Scaling of controlled variables for each controller channel is accomplished by means of the **actual value factor** and **actual value correction** parameters for the variant with 10 V / 20 mA measurement inputs. The **quantity** device parameter (°C / °F) has no function.

The **actual value factor** is the display range which corresponds to the measuring range (0...10 V, 0(4)...20 mA).

In order to obtain a good resolution of the measured values, the **actual value factor** is scaled internally in the 2,000 ... 20,000 range.

The value selected for the **actual value correction** parameter is added to the display value (after multiplication with the actual value factor).

Two measuring points are required in order to calculate the parameters (measured values in V / mA):

$$\text{Actual value factor} = \frac{\text{display value 1} - \text{display value 2}}{\text{meas. value 1} - \text{meas. value 2}} \cdot \text{measuring range}$$

$$\text{Actual value correction} = \text{display value} - \text{actual value factor} \cdot \frac{\text{meas. value} - \text{lower range limit}}{\text{measuring range}}$$

Example:

A pressure measuring transducer reads out a signal of 0 to 20 mA at 0 to 50 bar. In order to make use of broken sensor monitoring, the input at the R355 must be configured to 4 to 20 mA. The measured value is to be processed at a resolution of 0.01 bar.

Solution:

$$\text{Actual value factor} = \frac{50.00 \text{ bar} - 0.00 \text{ bar}}{20 \text{ mA} - 0 \text{ mA}} \cdot 16 \text{ mA} = 40 \text{ bar}$$

Consequently, the internal measuring range is **4,000** • 0.01 bar.
All other quantities and parameters refer to this representation.

$$\text{Actual value correction} = 0.00 \text{ bar} - 40.00 \text{ bar} \cdot \frac{0 \text{ mA} - 4 \text{ mA}}{16 \text{ mA}} = 10.00 \text{ bar} = 1,000 \cdot 0.01 \text{ bar}$$

Attention:

The internal representation of the R355 has no decimal point. The decimal point is adapted to the **actual value factor** in the configuration tool.

2.3.7 Using the Thermocouple Input As Linear Input

When the linear input has been selected (**sensor type** = *linear*), the thermocouple input is used without taking the reference junction into consideration.

In the case of high impedance sources, the measured value is influenced as a result of broken sensor monitoring:

Shift: approx. + 1.2 mV / k Ω

Attenuation: approx. 0.5% / k Ω

The **actual value correction** and **actual value factor** parameters are used to scale the measured value.

The scaled measured value is treated by the controller as a temperature value because the units of measure for the various controller parameters (e.g. setpoint or proportional band) are specified in °C or °F. Where control or monitoring of quantities other than temperature are involved, the unit of measure for the controlled variable should thus not be changed after scaling, because scaling is converted for °C / °F.

The **actual value factor** is the display range which corresponds to an input range of 0 to 50 mV.

The 0 mV measuring point is displayed as 0.0° C or 32.0° F, as long as **actual value correction** is set to 0.

The value assigned to the **actual value correction** parameter is added to the display value.

Two measuring points are required for calculating the parameter setting (measured values in mV):

$$\text{Actual value factor} = \frac{\text{display value 1} - \text{display value 2}}{\text{measured value 1} - \text{measured value 2}} \cdot 50 \text{ mV}$$

$$\text{Actual value correction} = \text{display value} - \frac{\text{measured value} \cdot \text{actual value factor}}{50 \text{ mV}} \quad \text{where unit of measure} = \text{°C}$$

$$\text{Actual value correction} = (\text{display value} - 32.0^\circ \text{ F}) - \frac{\text{measured value} \cdot \text{actual value factor}}{50 \text{ mV}} \quad \text{where unit of measure} = \text{°F}$$

Example:

Pressure needs to be monitored in addition to temperature control in °F. 44 mV are applied to the input at a pressure of 100 bar, and 0 bar corresponds to 0 mV. The measured value is to be transmitted via the interface with a resolution of 0.01 bar.

Solution:

The resolution of 0.1° F is replaced with a resolution of 0.01 bar for the interpretation of all temperature values.

$$\text{Actual value factor} = \frac{100.00 \text{ bar} - 0.00 \text{ bar}}{44 \text{ mV} - 0 \text{ mV}} \cdot 50 \text{ mV} = 113.64 \text{ bar} \quad \text{corresponds to } 1136.4^\circ \text{ F}$$

$$\text{Actual value correction} = (0.00 \text{ bar} - 3.20 \text{ bar}) - \frac{113.64 \text{ bar} \cdot 0 \text{ mV}}{50 \text{ mV}} = -3.20 \text{ bar} \quad \text{corresponds to } 32.0^\circ \text{ F}$$

2.4 Configuring Control Response

2.4.1 Controller Type

The **controller type** determines how system deviation is processed.

The type of manipulated variable output, i.e. the utilized actuators, depend upon the controller type.

This setting can be combined with all other configurations.

Controller Type	Processing
Unused (controller type 0)	This configuration is intended for unused channels. The actual value is only measured, without monitoring, error messages etc.
Measuring (controller type 1)	This configuration is intended for temperature monitoring. Limit value monitoring can be configured. System deviation is not used for any other purpose.
Actuator (controller type 2)	Same as controller type 1 (measuring) In addition, the actuator manipulating factor is read out with the actuating cycle.
Limit transducer (controller type 3)	The maximum manipulating factor is read out, if the actual value is less than the momentary setpoint. The minimum manipulating factor is read out, if the actual value is greater than the momentary setpoint plus the dead zone. Switching hysteresis is adjustable, and status changes are possible after each actuating cycle. Actuation cycle time is used as a time constant for an additional input filter.
PDPI controller (controller type 4, 5)	The PDPI control algorithm assures short settling time without overshooting. The actuating cycle is at least as long as the selected value. The dead zone suppresses switching back and forth between heating and cooling if no lasting deviation occurs. The controller selects controller type 4 or 5 itself, the user can enter either. <i>Type 5 is a pure PDPI step-action controller, and type 4 may include any other combination of actuators.</i>
Proportional actuator (controller type 6)	The manipulated variable is proportional to system deviation, and a static dead zone can be adjusted at the cooling side. Actuation cycle time is used as a time constant for an additional input filter. The controller type is not intended for temperature regulation, because it does not demonstrate the dynamics required for control without overshooting.

2.4.2 Controller Classes

The **controller class** determines how the controller processes input quantity actual and setpoint values.

This setting can be combined with all other configurations.

Controller Class	Processing
Fixed setpoint controller (controller class 0)	System deviation equals setpoint value minus actual value
Differential controller (controller class 1)	Actual value difference is controlled, i.e. actual value of the differential controller channel minus the actual value of the partner channel Due to the sampling sequence, it is advisable to position the partner channel upstream from the differential controller channel in high speed circuits. Limit value monitoring is relative to actual value difference, and not the two actual values.
Master controller (controller class 2)	Due to the fact that inputs are not normally assigned to the master controller, it must be configured as such to assure calculation of a suitable manipulated variable for the slave controller. Control dynamics are attenuated to assure that the manipulated variable used as a delta actual value remains steady. Actuation cycle time is used as a time constant for an additional input filter. The manipulated variable is added by the slave controller as a delta setpoint value. 1% manipulated variable is always delta setpoint value 1° C (independent of unit of measurement selection °C or °F).
Slave controller (controller class 3)	The manipulated variable of the partner channel is added to the setpoint value, but only if the partner channel is a master controller. 1% manipulated variable is always delta setpoint value 1° C. Any possible setpoint shifting depends upon manipulated variable limiting at the master controller, and thus has a maximum value of ± 100° C. If switching occurs to the proxy setpoint, the channel becomes a <i>fixed setpoint controller</i> , in which case nothing is added to the proxy setpoint value. All functions which effect setpoint values, as well as setpoints ramps, setpoint limiting or actuation, are applied to the setpoint sum.
Switching Controller (controller class 4)	If a control loop has only one actuator and two sensors, and if the sensor to be used depends upon the operating state, switching can be executed by a switching controller in combination with a fixed setpoint controller used as a partner channel. Configuration: The channel to which the first sensor and the actuator are connected is configured as a fixed setpoint controller (controller class = 0). The channel to which the second sensor (and no actuator) is connected is configured as a switching controller (controller class = 4), and the channel to which the first sensor is connected is set up as a partner channel. If switching is to be triggered via a binary input, the corresponding input is assigned to the fixed setpoint controller with function selection = 4 (switching controller active). Function: As long as the "switching controller active" bit has not been set in the controller function of the fixed setpoint controller, the fixed setpoint controller with the first sensor is active, and the switching controller with the second sensor is inactive. If the "switching controller active" bit at the fixed setpoint controller is set, the fixed setpoint controller is inactive. The switching controller is active in this case and utilizes the setpoint of the fixed setpoint controller (including setpoint limits and the proxy setpoint), as well as its actuator outputs. The internal statuses of the respectively inactive controller are frozen in order to assure bumpless switching in both directions. The controller on bit for the controller function in the fixed setpoint controller is also used for the respective switching controller. The two related channels are thus always switched on and off together. The switching controller's controller on bit cannot be changed. Limit value 1 is only monitored at the respectively active controller, and limit values 2 is always monitored at both.

Fixed Value Control

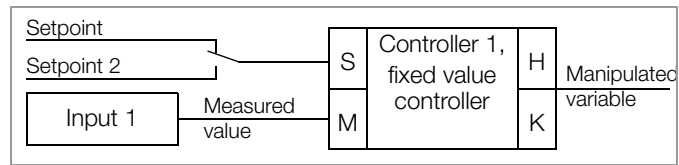

Differential Control

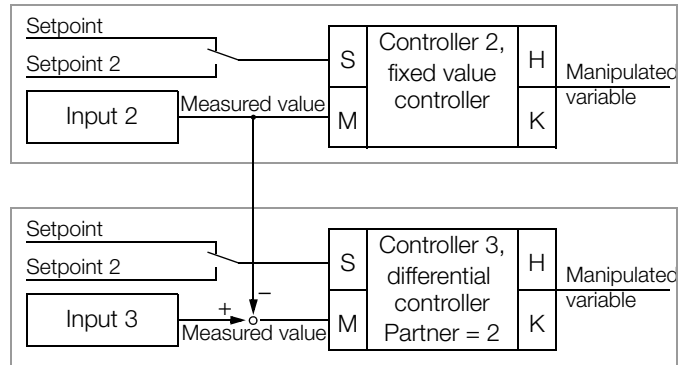

Cascade Control

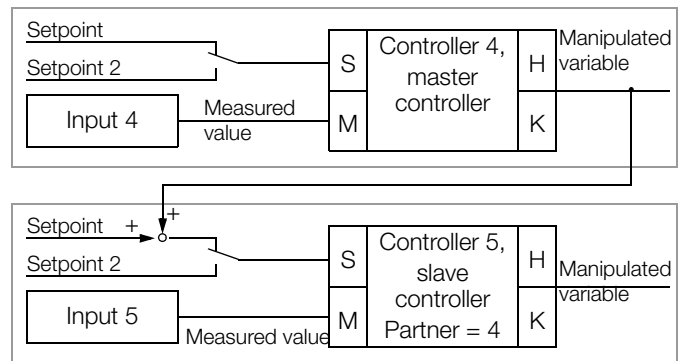

Switching Control

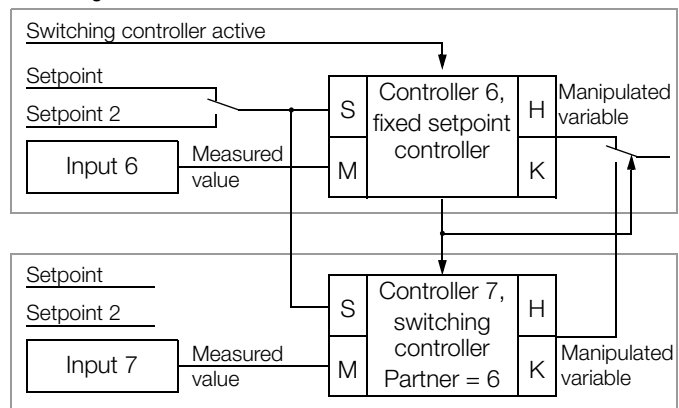

2.5 Regulating the Control Functions

With the controller function byte, eight functions can be regulated via the interface or else via binary input. Assignment to groups is possible, so that several channels can be controlled simultaneously.

2.5.1 Assignment to Groups

Individual controller channels can be assigned to one group by setting **group** in the **controller configuration** to a valid *group number* (from 0 to 3). In this way, channels assigned to a group can participate mutually in **actual value control**, selective changes to the **controller function** via binary input (see chapter 2.5.2 on page 15) or combining of channel-specific alarms into **group alarms** (see chapter 2.8.12 on page 25).

2.5.2 Setting Controller Functions via Binary Input

The bits included in **controller function** which are set via (bus) interface in order to activate individual functions, can also be set with the binary inputs. In this case, the binary input takes precedence over the interface. One input is required per function, and control can be executed per channel, for one group (1 to 3) or for all eight channels.

In the case of control per individual channel, the **output configuration** of the output is as follows:

Bit Number	Value	Meaning
0	1	Configuration as input
1	1	Control per individual channel
2 ... 4	0 ... 7	Channel number
5 ... 7	0 ... 7	Function selection

In the case of control per group, the **output configuration** of the output is as follows:

Bit Number	Value	Meaning
0	1	Configuration as input
1	0	Control per group
2, 3	0 / 1 ... 3	All 8 channels / group number
4 ... 6	0 ... 7	Function selection
7	0	—

Function selection:

Value	Meaning	Comment
0	Proxy setpoint active	see chapter 2.3.1
1	Actuation circuit	see chapter 2.6.1
2	Feed-forward control	see chapter 2.5.4
3	Temporary setpoint rise (Boost)	see chapter 2.6.2
4	Switching controller active	see chapter 2.4.2
5	Clear error	see chapter 2.7.1
6	Controller on	see chapter 2.8.1 and 5.4.3
7	Start self-tuning	see chapter 2.7.1

2.5.3 Manual Operation / Controller Off

The **controller on** bit in the **controller function** activates the controller channel (automatic operating mode). The controller outputs can then be driven in accordance with the controller's configuration.

If the controller channel has not been activated (**controller on** = 0), output performance is determined by the **manual instead of off** bit in the **controller configuration**:

- "Manual instead of off"** not set: Outputs are deactivated (off state). The integral-action component is cleared for PDPI controllers, i.e. the temperature must settle in once again when switched back on.
- "Manual instead of off"** set: The last active manipulated variable continues to be read out and can be changed with the **manual manipulating factor** (manual operating mode).
The integral-action component is not cleared for PDPI controllers, instead it is preset to the last (possibly changed) manipulated variable so that no jump occurs when switched back on.
In this way, for example, the manipulated variable can be temporarily frozen, or another operating point can be approached in a bumpless fashion.

In the event that both states, **controller off** and **manual operation**, are required independent of each other, the **manual instead of boost** bit is set in the **extended controller configuration**; **manual instead of off** is not set.

The **controller on** and **boost** bits in the **controller function** control performance:

- Controller on** not set: Outputs off
- Controller on** set and **boost** not set: Automatic operation
- Controller on** and **boost** set: Manual operation

2.5.4 Feed-Forward Control

Control quality can be significantly improved by means of feed-forward control where abrupt load fluctuations prevail when configured as a *PDPI controller*:

When the **feed-forward control** bit is set in **controller function**, the manipulating factor (integral-action component) of the controller is increased by a value equal to the **influencing quantity manipulating factor**, and when the **feed-forward control** bit is cleared, it is reduced by the same value.

Feed-forward control is inactive during self-optimization.

The **feed-forward control** bit is not (no longer) set after a device reset.

The feed-forward control is also active during manual operation or in the event of a sensor error.

Example:

If a machine requires an average of 70% heating power during production operation, but only 10% during idle time, the difference of the influencing quantity manipulating factor is set to 60%, and the **feed-forward control** bit is only activated during production.

2.6 Hot-runner Control

The manipulated value is read out in rapid cycles after setting the **hot-runner** bit in the **controller configuration**, i.e. actuation cycle time is 0.1 s regardless of the setting used for the **actuation cycle time** parameter.

The actuation circuit and temporary setpoint rise described below are even functional when the **hot-runner** bit is *not* set.

2.6.1 Actuating Circuit

The actuation circuit is enabled by setting the **actuation circuit** bit in the **controller function**.

The actuation circuit is only enabled for **controller type PDPI**. No actuation occurs for other controller types.

If the actuation bit is cleared, any currently active actuation operation is stopped immediately.

The actuation operation is started if the actual value is more than 2° less than the **actuation setpoint** after auxiliary voltage is turned on (reset), or after the off state has been ended, or if the actual value drops to more than 40° less than the **actuation setpoint** after an actuation operation has been completed or during dwell time.

Actuation continues until the actual value exceeds the **actuation value** minus 2° C.

The manipulated variable is limited to the **actuation manipulating factor**.

If the manipulated variable also needs to be read out as a rapidly pulsating signal, the channel must be configured as a **hot-runner (controller configuration)**.

Dwell time then begins, which is adjusted with **dwell time**.

The controller regulates temperature to the actuation setpoint.

The actuation operation is ended as soon as dwell time has expired.

The controller then regulates temperature to the valid setpoint.

If the currently valid setpoint is still so far beneath the actuation setpoint that the condition for ending actuation cannot be fulfilled, the actuation operation continues indefinitely. In this case, manipulated variable limiting by means of **maximum manipulating factor** is advisable.

The corresponding bits in **controller status** indicate when actuation and dwell time are active.

2.6.2 Temporary Setpoint Rise (Boost)

Temporarily increasing the setpoint, for example in the hot-runner control mode, can be used to free clogged mold nozzles of “frozen” material remnants.

This procedure is triggered by bit 3 of the controller function, which is set via the interface or the binary input. The process is ended by clearing the bit, or automatically after maximum boost duration has elapsed.

The relative increase is stored per channel in the setpoint rise parameter (PI = 08), and maximum boost duration is stored in the boost duration parameter (PI = 09).

Boosting effects only the setpoint or the proxy setpoint, and not the actuation setpoint or the ramp function.

2.6.3 Actual Value Control, Synchronous Heat-Up

The objective is to reduce thermoelectromotive forces within the group by minimizing dynamic actual value differences.

The slowest control system within the group dictates setpoint rise for all other control systems within the group to this end. This is also possible for several devices. Selected setpoint ramps and the actuation circuit are taken into consideration.

If the **actual value control** bit is set and assigned to a **group** (0 to 3) in the **controller configuration**, the channels which belong to the respective group participate in actual value control. **Controller type** must be set to **PDPI controller** for the participating channels to this end, and control must be activated, i.e. *controller on or self-tuning started* must be set in the controller function. In the **controller status** the corresponding bits indicate whether the actual value control is active and which channel is the slowest (compare chapter 5.4.6 on page 56).

The lowest actual value within the group, which can be made available to other devices as a **master actual value** via the bus, is determined. If the master actual value of another device in the same group is sent to the device, this is taken into consideration. In this way, many more than just eight channels can be heated up synchronously. All involved devices pass on their master actual values within a closed loop to this end, i.e. device 1 → device 2, device 2 → device 3, ... , last device → device 1.

After all channels within the group have reached their setpoints, the master actual value is set to 1800° C in order to indicate this fact.

Control response relative to the master actual value varies depending upon whether or not the **hot-runner** bit is set in the **controller configuration**:

In the **hot-runner control** mode, the master actual value determines the setpoints of all channels within the group, such that temperature difference remains minimal. If self-tuning is started at the beginning of the actuation process, for example because another tool with yet unknown control parameters is started up, the zones with default parameters are used and the self-tuning sequence is influenced such that no large temperature differences occur during self-tuning.

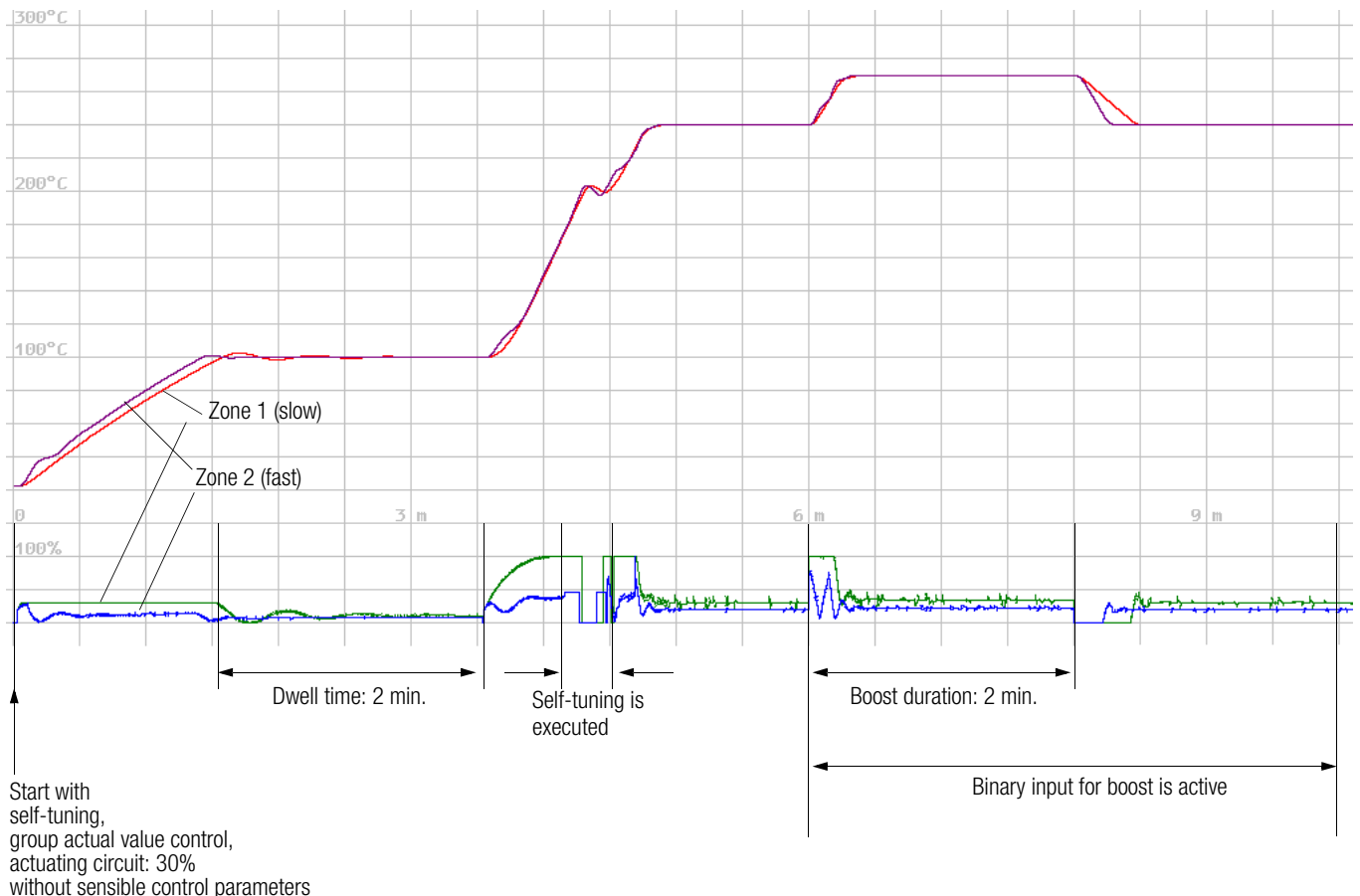

If the hot-runner bit has not been set, the master actual value is not used for **two-step, three-step or continuous action control**. Instead, an ideal ramp gradient is determined for all channels within the group, so that all temperatures increase at the same rate. In this case, self-optimization does not take actual value management into consideration.

2.7 Determining Controller Parameters

Proportional zone heating and cooling (Xpl / Xpll) parameters, **system delay (Tu)** and **actuation cycle time** must be determined in order to obtain optimized controller dynamics.

Appropriate values for controller amplification, derivative-action time, integral-action time and the measured quantity sampling rate are generated based upon this data internally by the controller.

2.7.1 Self-Optimization (self-tuning)

Self-optimization is used to optimize controller dynamics, i.e. the parameters **proportional zone heating and cooling (Xpl / Xpll)**, **delay (Tu)** and **actuation cycle time** are determined.

Preparation

- Complete configuration must be performed **before** self-optimization is started.
- The setpoint value is adjusted to the value which is required **after** optimization.
- If the self-tuning error bit for the channel error status is set, it must first be cleared.

Start

- Self-optimization is started by setting the **self-tuning on** bit in the **controller function**, provided that the **controller on** bit has also been set.
- The start command is accepted if **controller type** is set to *PDPI controller*, outputs are assigned to the channel and manipulated variable limiting is no less than 10%.

If the start command is rejected, the **start error** bit is set for the **channel error status** of the corresponding channel (see also **events data**).

- Self-optimization remains activated even if the **self-tuning on** bit is cleared again.

Sequence

- The setpoint value which was active at the time self-optimization is started remains valid – changes are not effective at first (slave controllers: changing delta setpoints have no effect).
- Activation or deactivation of the proxy setpoint is not effective.
- Selected setpoint ramps are not taken into consideration.
- If started at the operating point (actual value approximates setpoint value), overshooting cannot be avoided.
- In the case of 3-step controllers, cooling is activated if the upper limit value is exceeded in order to prevent overheating. Self-optimization then performs an oscillation test around the setpoint.
- The bottom 4 bits in **controller status** indicate the optimization phase.
- The **self-tuning on** bit is reset after optimization has been completed.
- If self-optimization is started via the binary input, the binary input must be deactivated before self-optimization has been completed, because it would otherwise be restarted upon its completion. Self-optimization cannot be aborted via the binary input.

Abort

- Self-optimization can be aborted at any time by clearing the **controller on** bit.
- If an error occurs during self-optimization, the controller no longer reads out an actuating signal and the **self-tuning error** bit is set for the **channel error status** of the corresponding channel (in **events data**). This is the case in the event of a sensor error, or if the parameters configuration for the channel has been changed such that self-optimization is no longer sensible.
- In the event of an error, the **self-tuning error** bit of the channel error status must be cleared before closed loop control mode operation can be restarted.

2.7.2 Manual Optimization

The parameters **proportional zone heating and cooling, delay** and **cycle time** are determined by means of manual optimization. An actuation test or an oscillation test is performed to this end.

Preparing for the Actuation Test or the Oscillation Test

- Complete configuration must first be performed for use of the controller.
- The actuators are deactivated by setting **controller on** to 0 in **controller function**.
- A recorder must be connected to the sensor and adjusted appropriately for prevailing circuit dynamics and the setpoint. If the case of differential controllers, the actual value difference must be recorded.
- On and off-time of the heating output must be recorded for 3-step controllers (e.g. with an additional recorder channel or a stopwatch).
- Set **controller type** to *limit transducer*.
- Set **cycle time** to its minimum setting (0.1 s).
- If possible, deactivate any manipulating factor limiting.
- Reduce (or increase) the setpoint so that overshooting and undershooting do not cause any impermissible values.

Performing the Actuation Test

- Set **dead zone** to *MRS (measuring range span)* for 3-step controllers (cooling may not be triggered).
Set **dead zone** to 0 for step-action controllers ("less output" must be triggered)
- Start the recorder.
- Activate the actuators by setting **controller on** to 1.
- Record two overshoots and two undershoots. The actuation test is now complete for 2-step controllers. Continue as follows for 3-step controllers:
- Set **dead zone** to 0 in order to cause further overshooting with active cooling output. Record two overshoots and two undershoots.
- Record heating output on-time T_I and off-time T_{II} for the last oscillation.

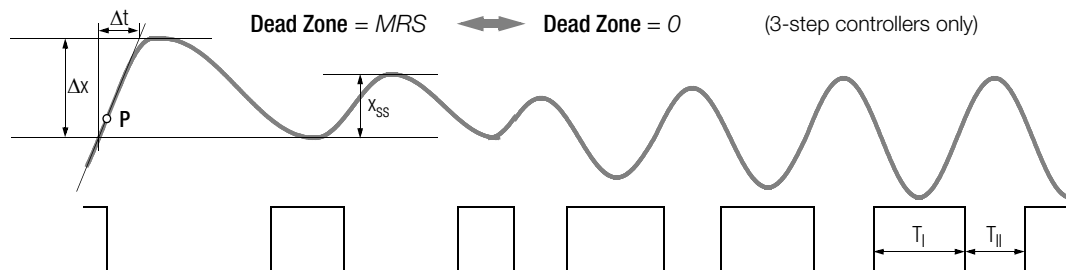

Figure 2 Characteristic Curve during Actuation Test

Evaluating the Actuation Test

- Apply a tangent to the curve at the intersection of the actual value and the setpoint, or the cut-off point of the output.
- Measure time Δt .
- Measure oscillation amplitude x_{ss} , or for step-action controllers overshooting Δx .

Parameter	Parameter Values			
	2-Step Controller	3-Step Controller	Continuous-Action Controller	Step-Action Controller ¹⁾
Delay (Tu)		$1.5 \cdot \Delta t$		$\Delta t - (T_y / 4)$
Cycle time		$T_u / 12$		$T_y / 100$
Proportional zone heating (Xpl)		x_{ss}	$2 \cdot x_{ss}$	$0.5 \cdot \Delta x$
Proportional zone cooling (Xpll)	–	$Xpl \cdot (T_I / T_{II})$	–	–

¹⁾ T_y = motor actuation time

If manipulating factor limiting was active, the proportional zone must be corrected:

- Xpl** multiply by 100% / **maximum manipulating factor**
- Xpll** multiply by –100% / **minimum manipulating factor**

Performing the Oscillation Test

If an actuation test is not possible, for example if neighboring control loops influence the actual value too greatly, if cooling must be active in order to maintain the actual value (cooling operating point), or if optimization is required directly to the setpoint for any given reason, control parameters can be determined by means of sustained oscillation. However, calculated values for delay may be too large in this case under certain circumstances.

The test can be performed without a recorder if the actual value is observed and times are measured with a stopwatch.

- Set **dead zone** to 0.
- Activate the actuators by setting **controller on** to 1, and start the recorder if one is used. Record several oscillations until they become uniform in size.
- Measure oscillation amplitude x_{SS} .
- Record on-time T_I and off-time T_{II} of the heating output for the oscillations.

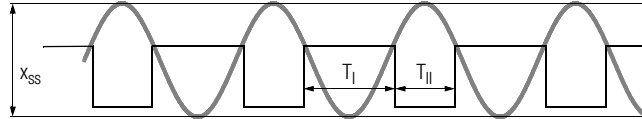

Figure 3 Oscillatory Characteristics

Evaluating the Oscillation Test

Parameter	Parameter Values			
	2-Step Controller	3-Step Controller	Continuous-Action Controller	Step-Action Controller ¹⁾
Delay (Tu) ²⁾		$0.3 \cdot (T_I + T_{II})$		$0.2 \cdot (T_I + T_{II} - 2Ty)$
Cycle time		$Tu / 12$		$Ty / 100$
Proportional zone heating (Xpl)	x_{SS}	$\frac{x_{SS} \cdot T_{II}}{(T_I + T_{II})}$	$2 \cdot x_{SS}$	$0.5 \cdot x_{SS}$
Proportional zone cooling (Xpll)	—	$Xpl \cdot (T_I / T_{II})$	—	—

¹⁾ Ty = motor actuation time

²⁾ If either T_I or T_{II} is significantly greater than the other, value Tu is too large.

Correction for manipulating factor limiting:

Xpl multiply by 100% / **maximum manipulating factor**

Xpll multiply by -100% / **minimum manipulating factor**

Correction for step-action controllers in the event that T_I or T_{II} is smaller than Ty:

Xpl multiply by $\frac{Ty \cdot Ty}{T_I \cdot T_I}$ if T_I is smallest, or by $\frac{Ty \cdot Ty}{T_{II} \cdot T_{II}}$, if T_{II} is smallest.

The value for Tu is very inaccurate in this case. It should be optimized in closed loop control mode.

Closed Loop Control Mode

The closed loop control mode is started after manual optimization has been completed:

- Set **controller type** to *PDPI*.
 - Adjust the setpoint to the required value.
 - The dead zone can be increased from **dead zone** = 0 for 3-step and step-action controllers, if control of the heating and cooling outputs, or more and less outputs, changes too rapidly due to an unsteady actual value.

2.8 Monitoring Functions

The results of individual monitoring functions are written to the **events data** bits, which can be queried via the (bus) interface, or read out selectively at the binary outputs.

2.8.1 Overview of Channel-Specific Alarms

These alarms are summarized for each channel in the channel error status word.

Bit no.	Meaning	Causes	Remedy	Channel Performance	Comment
0	Broken sensor	Interrupted cable	Inspect wiring and sensor	Depends upon configuration, e.g. read-out of sensor error manipulating factor	See chapter 2.8.7.
1	Polarity reversal	Polarity reversed at thermocouple or incorrectly connected Pt100			
2	2 nd upper limit value exceeded	Temperature too high	Inspect the actuators Acknowledge alarm in event of alarm memory	No influence on control, except when configured as a limiter (see 2.8.4)	See chapter 2.8.3.
3	1 st upper limit value exceeded				
4	1 st lower limit value fallen short of				
5	2 nd lower limit value fallen short of	Temperature too low			
6	Impermissible parameter	Transmitted parameter value out of limits Value has been rejected	Transmit plausible parameter value	No influence on control	Acknowledge alarm
7	Heating current not off with deactivated actuating signal	Short-circuited actuator	Inspect actuator and heating current circuit	No influence on control	See chapter 2.8.6.
8	Too little heating current with active actuating signal	Actuator interrupted / fuse blown			
9	Heating circuit error	Sensor does not measure correctly Heating current circuit interrupted	Inspect sensor, actuator and heating current circuit	No manipulated variable until error is acknowledged	See chapter 2.8.5. Acknowledge alarm
10	Self-tuning start-up error	Controller not activated Controller is configured incorrectly Controller cannot be self-tuned	Configure controller correctly	No influence on control	See chapter 2.7.1. Acknowledge alarm
11	Self-tuning error and abort	Sensor error has occurred Configuration has been changed during self-tuning		The channel is deactivated. Forced cooling until the error is acknowledged if an upper limit value has been exceeded	
12	Too big heating current with active actuating signal	Shunt circuit at actuator Current nominal value too little	Inspect actuator / heating current circuit Adjust current nominal value correctly	No influence on control	See chapter 2.8.6

2.8.2 Overview of Device-Specific Alarms

These alarms are summarized in the device error status word.

Bit no.	Meaning	Causes	Remedy	Device Performance	Comment
0	Analog error	Defective device	Repair	All channels are deactivated	Error LED lights up
		No 24 power supply at the inputs	Check wiring		
1	Overload, heating current 1	Secondary heating current greater than 1.2 A Interference voltage	Use a different transformer Transformer secondary must be potential-free	No influence on control	
2	Overload, heating current 2				
3	Overload, heating current 3				
4	Heating voltage overload	Secondary heating voltage greater than 60 V Interference voltage	Use a different transformer Transformer secondary must be potential-free		
6	Reference junction error	Wiring to the remote cold junction is interrupted or short-circuited	Inspect wiring	Control is continued with an assumed reference junction temperature of 30° C.	
		Defective reference junction	Replace reference junction		
7	EEPROM error	Implausible parameter values in memory	Restore default settings and reenter parameter values	All outputs are low	Error LED lights up See chapter 2.10. Acknowledge alarm
		Defective parameters memory	Repair		
8	Group output error	Inactive output has high level signal (> 14 V), or active output has low level signal (< 7 V)	Correct wiring error or short-circuit	Control is continued	Error LED lights up
		Output defective	Repair		
9	Mapping error	Sensor and heater assigned to different channels	Correct wiring or configuration	All manipulated variables off until the error is acknowledged	See chapter 2.9.3 Acknowledge alarm
10	Parameter error	Program sequence error	EMC measures	Parameter value is corrected from parameter value memory	
11	Bus connection error	FPGA does not load	Repair	All channels are deactivated	Error LED lights up
12	24 V error	Not all +24 V I/O connections are supplied with power	Check wiring	Control is continued	
		Defective, or internal fuse has blown	Repair		
13	CRC error	Faulty parameter set DB (DB100) transmitted from CPU to controller	Download parameter set DB from controller or config tool into CPU	Parameter set has not been accepted by the controller	Acknowledge error

2.8.3 Limit Value Monitoring

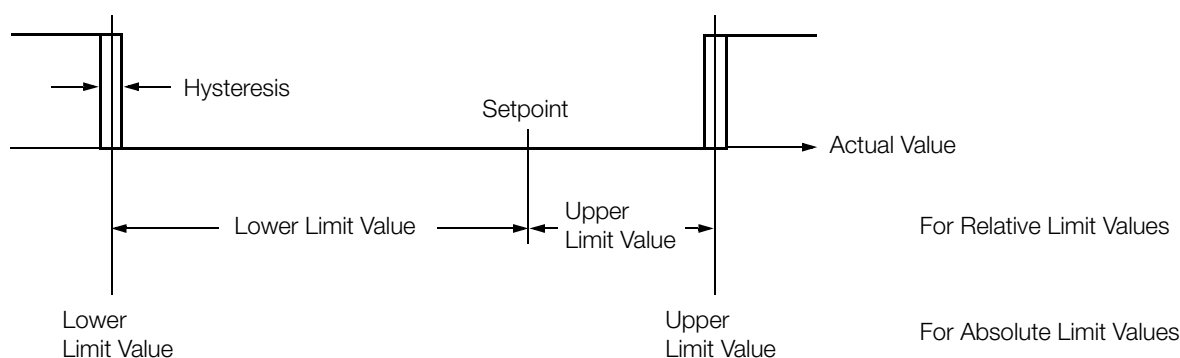

Figure 4 Schematic Representation of Limit Value Monitoring

Actuation Suppression

Alarm suppression is active during actuation (**actuation suppression** bit set in **limit value configuration**) until temperature has exceeded the lower limit value for the first time. During cooling, suppression is active until temperature has fallen below the upper limit value for the first time.

Suppression is active when auxiliary power is activated, if the momentary setpoint is changed or the proxy setpoint is activated, or if switching takes place from controller off to controller on.

Alarm Memory

If alarm memory is active (**alarm memory** bit set in **limit value configuration**), any bit which has been set in the **channel error status** remains set until it is cleared.

2.8.4 Limiter

If a controller needs to be deactivated in the event of a limit value violation within the control loop, the channel must be configured as a limiter. In this case, the controller responds just as it would if the “**controller on**” bit were not set in the **controller function** (PI = 20h). (Refer to chapter on manual operation 2.5.3)

The limiter can be combined with all **controller types** and **controller classes**.

- The limiter bit is set in the **limit value function** parameter (PI = 36h) in order to activate the **limiter** function.
- The limiter reacts to the **second limit values** (PI = 04h and 05h), which must be accordingly adjusted and configured. (See also chapter 2.8.3)
- As soon as a second limit value is violated, i.e. when either bit 2 or 5 is set in the **channel error status**, the controller is deactivated. If neither of these bits is set, the controller is reactivated.
- If the controller is to remain continuously deactivated after limit value monitoring has been triggered, the “**save alarm 2 active**” bit must be set in the **limit value function** parameter (PI = 36h).
- **Channel error status** bits 2 and 5 must then be cleared in order to reactivate the controller.
- This is also possible with a binary input by means of the **clear error** function (see also chapter 2.5.2).

2.8.5 Heating Circuit Monitoring

- Heating circuit monitoring is activated with the **heating circuit monitoring** bit in the **limit value configuration**.
- The controller must be configured as **controller type PDPI**, discontinuous or continuous heating with a **maximum manipulating range of** greater than or equal to 20%.
- No monitoring takes place during self-optimization.
- The monitoring function utilizes the **delay Tu** and **proportional zone heating Xpl** control parameters, which must be correctly optimized for this reason. In the event of manual optimization or subsequent adaptation of control parameters, a lower limit for **Tu** must be maintained. The lower limit is:

$$\min. Tu = 2 \cdot Xpl / (\Delta x / \Delta t) \quad \Delta x / \Delta t = \text{maximum temperature rise during actuation with 100\% on-time.}$$
 The limit is cut in half with continuous heating.
- An error message occurs at approximately 2 times Tu, if heating is discontinuous and the measured temperature increase is too small, or immediately if temperature plunges rapidly, as would not normally be possible. This may be caused by:
 - Polarity is reversed at the sensor, or the sensor is short-circuited.
 - No sensor is installed, the sensor has slipped out of place or has been installed at an incorrect position.
 - The heating current circuit is interrupted or has not been switched on.
 - The actuator is defective.
- In the event of error, the outputs are deactivated and the **heating circuit error** bit is set for **channel error status** (see also **events data**).
- The controller channel remains off until the **heating circuit error** bit is cleared.

2.8.6 Heating Current Monitoring

Connection

- 1 to 3 identical external summation current transformers can be connected (for all 8 channels simultaneously). The controller's current inputs are dimensioned for 1 A / 50 / 60 Hz.
The current value which results in a secondary value of 1 A must be entered to the **summation current transformation ratio** parameter.
- A voltage transformer can be connected in order to compensate for heating voltage fluctuation.
- All channels are monitored whose current is fed through the transformer.

Parameters Configuration

- The current values (sum of phases 1 through 3) to be monitored must be entered to the **heating current nominal value** parameter for each monitored channel. Channels which are not monitored must be set to 0.0 A.
- The open-circuit voltage value which prevails at nominal primary heating voltage must be entered to the **heating voltage transformer secondary voltage** parameter in order to activate compensation. Compensation is deactivated if a value of less than 10.0 V is entered.
- Automatic adjustment of **nominal heating current values** and **secondary heating voltage** can be activated by setting the parameter **device control** (PI=32h) to 55h.

Write		Read		Meaning
Bit Number	Code	Bit Number	Value	
0 ... 7	55h	4 ... 7	5h	Determination of heating current nominal values start / running
	—		0h	finished

Nominal heating current values are thus determined for all channels with a discontinuous-action heating output, and monitoring is thereby activated.

If a value of 10.0 V or less is measured for secondary heating voltage, the value remains at 0.0 V and compensation is inactive. If a value of at least 10.0 V has already been selected for secondary heating voltage, no new value is determined for compensation. Normal control operation is interrupted by this measurement for approximately 1 second. Due to the fact that a currently running self-tuning process would be rendered useless in this case, the measurement is not performed as long as self-tuning is still active at any given channel or channels.

Function

- If heating current monitoring has been activated for at least one channel, the controller runs through a cycle of operating states (depending upon the **delay Tu** parameter) such that heating is only activated at one of the channels to be monitored (all other heaters are off), and all heaters are off. In this way, heating current can be measured at the individual channels with the summation current transformers. The measuring cycle is ideally adapted to paths when the **heating current sampling cycle** parameter is set to 0 = Auto.
- The measuring cycle can also be specified by setting the **heating current sampling cycle** parameter accordingly.
- If a secondary heating voltage value within a range of 10.0 V and 50.0 V has been selected, measured current values are compensated:

$$\text{monitored current} = \frac{\text{measured current} \cdot \text{secondary heating voltage}}{\text{measured voltage}}$$

This allows for more accurate monitoring, for example in the case of parallel connected heaters.

- Monitoring and possible error messages take place with reference to the states:
 - Heat off and current is present → Error: **Heating current not off**
 - Heat on and too little current → Error: **Too little heating current**
 - Heat on and too big current → Error: **Too big heating current**
- **Too little heating current** is indicated if the nominal heating current value is fallen short of by more than 20% with inactive heating voltage compensation, or if the nominal heating current value is fallen short of by more than 5% with active heating voltage compensation.
The same limits apply when **heating current** is **too big**.

Monitoring 16/24 Channels

- Up to 3 devices can be connected via binary inputs and outputs such that all heating current for these 3 devices is monitored via heating current acquisition at the first device. This is advisable, for example, if only a small amount of heating current per device is being monitored.
- The monitoring function is limited as regards measuring technology, if the smallest heating current does not make up an appreciable portion (approx. 2%) of primary transformer current.
- The devices are connected via accordingly configured binary inputs and outputs in order to synchronize measurement:

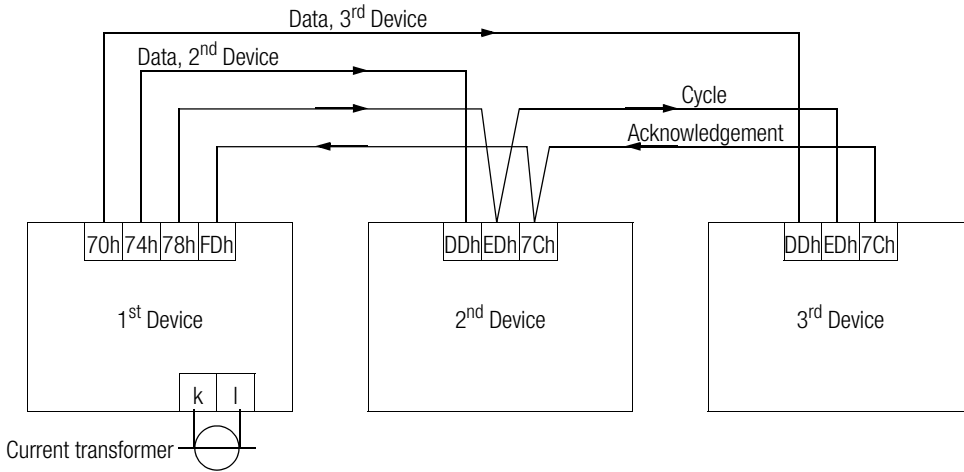

Figure 5 Wiring Diagram with Output Configuration Values

- Parameters for **heating current nominal values** at all 3 devices are configured at the 1st device. Automatic determination (see above) takes place at all 3 devices, if the binary inputs and outputs are correctly configured and connected. Any heating current parameter settings at the 2nd and 3rd devices are ignored.
- The **heating current sampling cycle** *must* be additionally set at the 1st device. The ideal value for rapid error detection is roughly half of delay time T_u , which means that the **heating current sampling cycle** should be set to the smallest value for 50% delay time of all monitored channels.
- The error message appears in the error status of the respective channel of the respective device.
- The error **too big heating current** is **not** registered for the 2nd and 3rd device.

2.8.7 Performance in the Event of Sensor Error

In the event of a broken sensor, thermocouple polarity reversal or short-circuiting of the Pt100, the **broken sensor** bit or the **polarity reversal** bit is set for **channel error status**.

The controller outputs respond as follows:

- No response occurs if **controller type** is set to *off*, *measure* or *actuator*.
- If **controller type** is set to *limit transducer*, *PDPI step-action controller* (controller type 5) or *proportional element*, the **sensor error manipulating factor** is read out in the automatic mode.
- If **controller type** is set to *PDPI controller* (=4) performance depends upon the selected **sensor error manipulating factor**:
 - Where **sensor error manipulating factor** = 0%, or minimum (–100%) or maximum (100%) manipulating factor:
The sensor error manipulating factor is read out.
 - Where **sensor error manipulating factor** = any other value:
After the control system settles in, a “plausible” manipulating factor is read out which keeps the temperature as close as possible to the setpoint.
If the control system has not yet settled in (during start-up, after a reset), the sensor error manipulating factor is read out.
If the controller is configured as a hot-runner controller, the “plausible” manipulating factor is averaged so that fluctuation throughout the injection cycle is averaged as well.

2.8.8 Monitoring the Binary Outputs

All binary outputs which have not been configured as inputs are monitored for short-circuiting and incorrect triggering. 2 times 24 bits are included in **output error**, which are set if the output is active although no signal is present at the terminal (short-circuit), or if the output is inactive and a signal is present at the terminal, i.e. the output is triggered due to a wiring error etc. Only the **operating current group error outputs** are not subject to output monitoring, so that they can be parallel connected amongst several devices.

2.8.9 Device Errors

Appropriate bits are set in **device error status** and the **error LED** at the front of the housing lights up if:

- Measured value acquirement is defective
- An error has been detected in the digital hardware
- An error in the parameters memory has been discovered
- An output monitoring error has occurred

Appropriate bits are also set if:

- Overload occurs at the heating current monitoring inputs
- The reference junction is interrupted or short-circuited

2.8.10 Clearing Error Bits

Several of the error bits in the **channel error status** and the **device error status** must be acknowledged because they are not cleared by the controller (except after a reset). This can be accomplished by overwriting the error status words via the interface as described in chapter 5.4.3.

The following bits in the **channel error status** can also be cleared via a binary input by adjusting the controller function selection setting to *clear errors* (see also chapter 2.5.2):

- Limit value error for alarm memory
- Heating circuit error
- Self-tuning start-up error
- Self-tuning error

Newly occurring errors are not suppressed.

The signal at the binary input must be applied for at least 100 ms.

2.8.11 Read-Out of Channel-Specific Alarms

Each channel has its own **channel error mask**, by means of which the errors to be read out via a binary output are selected from the **channel error status** (see chapter 5.4.7 on page 57 for details regarding error bits).

The **output configuration** of the selected output is set as follows for read-out:

Bit Number	Value	Meaning
0	0	Configuration as output
1	1	Single channel
2 ... 4	0 ... 7	Channel number
5	0	—
6	0 / 1	Operating current / closed-circuit current
7	1	Configuration as alarm output

2.8.12 Read-Out of Group Alarms or Self-Optimization Active Status

Eight **group error masks** can be programmed, by means of which the group errors are selected which are to be read out via a binary output (see chapter 5.4.8 on page 57 for details regarding error bits).

The **group alarms** are comprised of the channel-specific alarms by linking the alarms of all channels which belong to the same group by means of OR functions (see also chapter 2.5.1 on page 15).

The **output configuration** of the selected output is set as follows for the read-out of group alarms or the status indicating that self-optimization is still active or defective at some channel:

Bit Number	Value	Meaning
0	0	Configuration as output
1	0	Group error
2 ... 6	1 ... 8 9 10 ... 13	Group error 0 ... 7, Self-tuning in progress or self-tuning error Group error 0 ... 3
7	0 / 1	Operating current / closed-circuit current

2.9 Special Functions

2.9.1 Control of Continuous Outputs

The **momentary state of the continuous outputs** can be read in at any time with PI = E1h (see chapter 5.9 on page 60). The value range from 0 ... 1000 corresponds to 0 ... 20 mA and/or 0 ... 10 V.

If individual continuous outputs are not required for a controller function, they can be configured as **free outputs** and are thus available for independent read-out.

The output configuration (PI = 37h) must be set to the value 40h for this purpose so that the output can be set to PI = E1h by writing (see chapter 5.9 on page 60). In this process, only those statuses are adopted that are associated with free outputs.

2.9.2 Data Logger

The data logger has enough capacity for 3600 sampled value pairs including actual values and manipulated variables for all 8 channels. Recording is started over each time the device is reset, and data are lost if auxiliary power fails.

After memory has been filled to capacity with 3600 entries, the oldest values are deleted as new ones are recorded.

The **logger sampling cycle** (PI = 92h) can be configured within a range of 0.1 to 600.0 seconds. This results in recording times of 0.1 to 600 hours (6 minutes to 25 days).

In order to avoid overwriting any existing data, the recording can be stopped either via binary input (output configuration = CDh) or via interface (logger control (PI=93h) = 1).

The **number of samples** which can be read out can be queried with PI = 98h.

Actual values and manipulated variables are read out separately, and read-out is controlled by the **read-out starting point sampled values** (for actual values PI = 94h, for manipulated variables PI = 95h).

Read-out starting points can be envisioned as flags for a sampled actual value or manipulated variable, as of which the sampled values are read out during the next read operation. The very first sampling is flagged after a reset.

The respective read-out starting point indicates how many samplings are read from the recent past up to the current point in time. The read-out starting point is increased each time sampled values are saved.

The value cannot be greater than the number of samplings (PI = 98h).

Sampled values are read out with PI = 96h for actual values and PI = 97h for manipulated variables. Memory contents are not changed by read-out.

Each time an entry is read out via service interface or RS 485 bus (EN60870 or Modbus protocol), the read-out starting point value is automatically reduced so that the next read request accesses the next entry.

If read-out starting points are not manipulated via the interface, all sampled values can be picked up continuously and uninterruptedly by means of downloading at regular intervals (before old values are overwritten).

If sampled values are read out, the respective read-out starting point is automatically reduced such that the next read-out of sampled values occurs uninterruptedly, and without overlapping. Up to 120 values (15 samplings x 8 channels), or 8 x "read-out starting point" values can be requested.

Via the backplane bus 4 words are read at once. The read-in starting point is not reduced automatically, but rather as a result of writing the value -1 to the read-in starting point.

The **time of the last sample** can be queried with PI = 99h.

Example:

- The logger sampling cycle is set to 10 seconds (PI = 92h: 100). This corresponds to a total recording time of 10 hours.
- Auxiliary voltage for the instrument was switched on about 3 hours ago, and no sampled values have yet been queried. Querying of the quantities "read-out starting point sampled actual values" (PI = 94h), "read-out starting point sampled manipulated variables" (PI = 95h) and "number of samplings" (PI = 98h) results in approximately $1080 = 3 \times 60 \times 60 / 10$.
- Samplings for all 8 actual values over the last 15 minutes are now to be read out. The "read-out starting point sampled actual value" (PI = 94h) must be set to $90 = 15 \times 60 / 10$ to this end.
- The 90×8 sampled actual values can now be picked up.
- The "read-out starting point sampled actual value" (PI = 94h) is then reset to zero.
- The "read-out starting point sampled manipulated variable" (PI = 95h) remains unchanged.

2.9.3 Checking Sensor and Heater Assignments (mapping)

This function is used to check for correct wiring of the heater and the sensors.

Any included cooling system is not taken into consideration because the function is typically activated prior to initial heat-up, at which time the zones are cold.



Please note: This function is intended to provide assistance in testing, but it is not capable of preventing damage resulting from overheating due to incorrect wiring.

Independent monitoring of actual temperature is required under certain circumstances.

Preparation:

- **Controller type** must be set to *PDPI controller* for all control loops under test. Channels set to other options are not tested.
- The duration of testing for each individual channel depends upon the **delay** parameter. If the control parameters have already been optimized, the delay value need not be changed because it is already ideal. Otherwise, the delay should be set to approximately the time it takes for temperature in the respective zone to climb several degrees after the heat has been switched on.
- **Test time** is calculated for each channel based upon delay. Test time is twice as long as **delay**, or at least 10 seconds and not more than 5 minutes.



Attention!

If test time is too long, overheating may occur if a sensor cannot be assigned.

For example if the sensor is short-circuited, or if it is connected to another device.

Sequence:

- Checking sensor and heater assignments can be initialized from any state by transmitting AAh code for the **device control** parameter (PI = 32h).

Write		Read		Meaning
0 ... 7	AAh	4 ... 7	Ah	Monitoring of sensor/heating assignment start / running
	AAh		0h	stop / finished

- Testing is conducted during the initial phase (stabilization phase) to make sure that temperatures do not rise when all of the outputs of the channels under test are inactive. The duration of the stabilization phase is equal to the maximum test time value.
- Assignments are checked during the second phase for each individual channel, one after the other. Heat is switched on for the channel currently under test to this end, and all measured temperature values are observed which demonstrate a change of more than 5°. Any manipulating factor limiting, or the actuation circuit, is taken into consideration.
- Heat is switched off no later than after test time has elapsed, and the process is continued with the next channel.
- If no errors are detected, the controller returns to the selected operating mode after testing has been completed.
- If an error is detected, the **mapping error** bit is set for the **device error status**, and all heating and cooling outputs for all channels remain inactive until the mapping error bit is acknowledged.

Abort:

- Testing can be aborted at any time by transmitting the AAh code for the **device control** parameter.
- Testing is ended prematurely and the **mapping error** bit for the device error status is set, if the measured temperature value of any given channel rises excessively. The respective thresholds amount to 20° during the stabilizing phase and 50° during the second phase. Subsequent channels are then no longer tested.
- The same applies if temperature falls below the measuring range due to a sensor with polarity reversal.

Evaluation:

The results of the test appear in the **controller status** and in the **channel error status**:

- The **mapping address** for the **controller status** indicates the address of the sensor which has responded to the heater. The mapping address is only valid if the **mapping completed** bit for the **controller status** is set (see also chapter 5.4.6 on page 56).

The **mapping error** bit for the **device error status** is set in the event that any of the following errors occurs:

- The **mapping address** does not coincide with the channel number.
Cause: Sensor or heater swapped, or excessive thermal coupling.
- If the **mapping completed** bit for the **controller status** is not set, even though the channel has been tested, no temperature change has been detected before test time elapsed.
Cause: Test time was too short, i.e. a delay time has been selected which is too short, the heater is not active, the sensor is short-circuited or the sensor or the heater has been connected to another device.
- If a negative temperature change has been detected, the **polarity reversal** bit for the **channel error status** of the channel with the negative temperature change is set.
Cause: sensor polarity reversed.
- If testing is ended prematurely due to an unexpected temperature rise, the **broken sensor** bit for the **channel error status** of the channel which demonstrated the temperature rise is set.
Cause: The sensor is assigned to another device, the heater is being controlled by another device or excessive thermal coupling to the heater of another device prevails.
- The **broken sensor** and **polarity reversal** bits remain set until the mapping error is acknowledged.

2.9.4 Alarm History

Alarm history includes 100 error status entries with their respective time stamps.

Whenever at least one entire bit of the overall error status changes (compare PI = 21h or event data), the complete error status is saved with the current time stamp.

Recording is started over each time the device is reset, and data are lost if auxiliary power fails.

After memory has been filled to capacity with 100 entries, the oldest entry is deleted each time a new one is recorded.

The **number of entries** in alarm history can be queried with PI = 2Fh.

Read-out of alarm history entries is controlled with the **alarm history read-out starting point** value (PI = 2Dh).

This value specifies how many entries, from the past up to the current point in time, can be read out. The value cannot be greater than the number of entries (PI = 2Fh).

The read-out starting point can be envisioned as a flag for the entry which will be read out in response to the next read request.

The first entry is flagged after a reset, and the read-out starting point value is increased each time a new entry is saved to memory.

The **time stamp** is generated by a simple elapsed time meter, and not a real-time clock, i.e. the elapsed time meter starts again at zero after a device reset (1 January 00, 0:00 o'clock). In order to establish a relationship to real time, the current status of the elapsed time meter can be set to momentary time and date with PI = 90h.

Alarm history entries are read out with PI = 2Eh. Memory contents are not changed by read-out. The format of alarm history entries is described in chapter 5.4.9 on page 57.

Each time an entry is read out via service interface or RS 485 bus (EN60870 or Modbus protocol), the read-out starting point value is automatically reduced so that the next read request accesses the next entry.

Note: This is also the case even if not all 15 words are requested at once.

If the read-out starting point is not manipulated via the interface, all entries can be picked up continuously and uninterruptedly by means of read-out at regular intervals (before old values are overwritten).

Due to the fact that not all 15 words can be read at once via the backplane bus, the read-in starting point is not reduced automatically, but rather by writing the value -1 to the read-in starting point.

2.10 Parameter Sets

There are three parameter sets stored to non-volatile memory.

The device works with the momentary parameter sets, and only this set is effected by changes to individual parameters.

The two background parameter sets can be overwritten with the momentary parameter set, or loaded as the momentary parameter set. This allows for easy switching back and forth between two applications, and intermediate statuses can be saved during testing.

The default parameter set is stored to the firmware, and the controller can thus be reset to its default parameters at any time by overwriting the momentary parameter set.

Complete parameter sets (640 bytes) are exchanged between the controller module and the CPU via a transfer buffer in RAM, in order to rule out any possible data conflicts during transmission resulting from inconsistent settings. The entire parameter set is activated, all at once, after transmission has been completed.

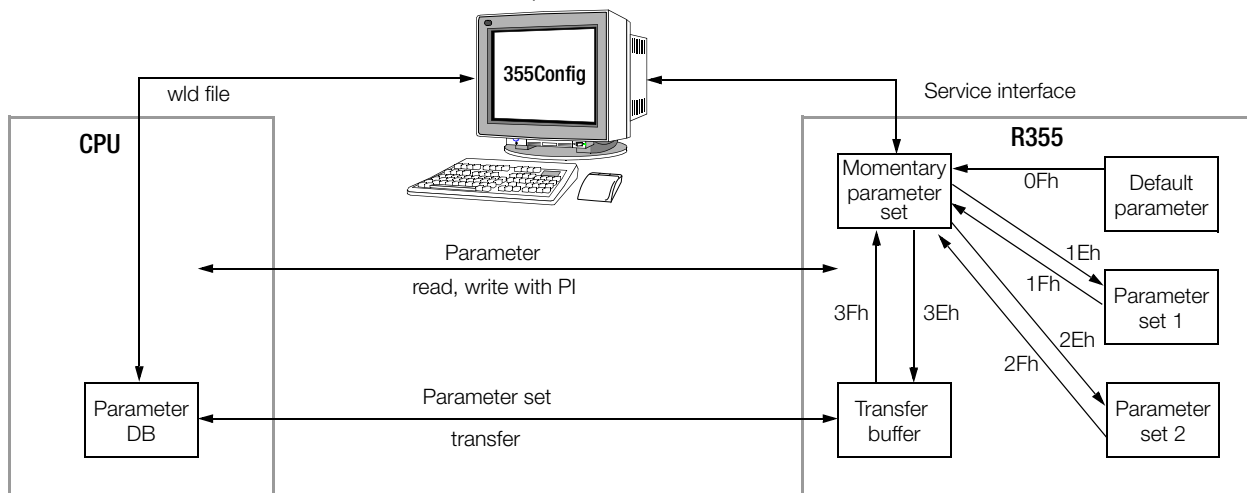

Copying is controlled by means of the **device control** parameter (PI = 32h).

Bit Number	Value	Meaning	Comment
0 ... 7	0Fh	Load default settings to momentary parameter set	Cannot be read back
	1Eh	Save momentary parameters to parameter set 1	
	1Fh	Load parameter set 1 as momentary parameters	
	2Eh	Save momentary parameters to parameter set 2	
	2Fh	Load parameter set 2 as momentary parameters	
	3Eh	Copy momentary parameter set in transfer buffer	
	3Fh	Load transfer buffer in momentary parameter set	

The copying procedure effects all parameters and configurations listed in the table on page 29.

Overview of all Parameters and Configurations

The parameters listed below are saved to an EEPROM, and are not lost even in the event of mains power failure. Other quantities are stored to volatile RAM, or are permanently programmed. A complete list of all parameter indices (PI) is included in chapter 5.1 on page 51.

PI	Parameter Designation	U/M ¹⁾	Format	Setting Range	Default	Comment
Temperature Parameters						
00h	Setpoint	0.1°	± 15 bit	Minimum ... maximum setpoint	0.0° C	
01h	First upper limit value	0.1°	± 15 bit	0.0° = off, -MRS ... +MRS ¹⁾	0.0°	For Relative Limit Value
				0.0° = off, -MRS ... +MRS		For absolute LV and diff. controller
				0.0° C / 32.0 °F = off, MRL ... MRU		For abs. LV and abs. value controller
02h	First lower limit value	0.1°	± 15 bit	Same as first upper limit value	0.0°	
03h	Proxy setpoint	0.1°	± 15 bit	Same as setpoint	0.0° C	
04h	Second upper limit value	0.1°	± 15 bit	Same as first upper limit value	0.0°	
05h	Second lower limit value	0.1°	± 15 bit	Same as first upper limit value	0.0°	
06h	Minimum setpoint	0.1°	± 15 bit	MRL ... maximum setpoint ¹⁾	0.0° C	For absolute value controller
				-MRS ... maximum setpoint		For differential controller
07h	Maximum setpoint	0.1°	± 15 bit	minimum setpoint ... MRU ¹⁾	600.0° C	For absolute value controller
				minimum setpoint ... MRS		For differential controller
08h	Setpoint rise (Boost)	0.1°	± 15 bit	-MRS ... +MRS	0.0°	
09h	Boost duration	0.1 s	± 15 bit	0.0 ... 3000.0 s	0.0 s	See chapter 2.5.3 on page 15
0Ah	Actuation setpoint	0.1°	± 15 bit	Same as setpoint	0.0° C	
0Bh	Dwell time	0.1 s	± 15 bit	0.0 ... 3000.0 s	0.0 s	See chapter 2.6.1 on page 16
0Ch	Actual value correction	0.1°	± 15 bit	-MRS ... +MRS ¹⁾	0.0°	See chapter 2.6.3 on page 17
0Dh	Actual value factor	% / 0.1°	± 15 bits	10.0 ... 1800.0 % / °C	100.0 %	See chapter 2.3.5 on page 10
0Eh	Setpoint ramp, up	0.1° / min.	± 15 bit	0.0° = off, 0.1° ... MRS ¹⁾	0.0	See chapter 2.3.1 on page 9
0Fh	Setpoint ramp, down	0.1° / min.	± 15 bit	0.0° = off, 0.1° ... MRS ¹⁾	0.0	
Control Parameters						
10h	Proportional zone heating	0.1°	± 15 bit	0.0° ... MRS ¹⁾	50.0°	See chapter 2.7 on page 18
11h	Proportional zone cooling	0.1°	± 15 bit	0.0° ... MRS ¹⁾	50.0°	
12h	Dead zone	0.1°	± 15 bit	0.0° ... MRS ¹⁾	0.0°	Not for 2-step controllers
14h	System delay	0.1 s	± 15 bit	0.0 ... 3000.0 s	50.0 s	See chapter 2.7 on page 18
15h	Actuation cycle time	0.1 s	± 15 bit	0.1 ... 300.0 s	1.0 s	
16h	Actuator manipulating factor	%	± 7 bit	Min. ... max. manipulating factor	0%	
17h	Actuation manipulating factor	%	± 7 bit	Min. ... max. manipulating factor	100%	See chapter 2.6.1 on page 16
18h	Motor actuation time	0.1 s	± 15 bit	1.0 ... 600.0 s	60.0 s	With step-action controllers
19h	Influencing quantity manipulating factor	%	± 7 bit	Min. ... max. manipulating factor	0%	See chapter 2.5.4 on page 16
1Ch	Minimum manipulating factor	%	± 7 bit	-100 ... 0%	-100%	Not with step-action controllers
1Dh	Maximum manipulating factor	%	± 7 bit	0 ... +100%	100%	Not with step-action controllers
1Eh	Sensor error manipulating factor	%	± 7 bit	Min. ... max. manipulating factor	0%	See chapter 2.8.7 on page 24
1Fh	Switching hysteresis	0.1°	± 15 bit	0.0° ... MRS ¹⁾	4.0°	For limit value monitoring and limit transducers
Control Commands (further PIs are given in chapter 5.4 on page 54)						
20h	Controller function	bit	8 bit	See chapter 5.4.2 on page 54	0 = off	
22h	Controller configuration	bit	16 bit	See chapter 5.4.4 on page 56	1 = PDPI	
23h	Extended controller configuration	Bit	8 bit	See chapter 5.4.5 on page 56	0	
25h	Oscillation hold-off	0.1 s	8 bit	0.0 = off, 0.3 ... 25.0 s	0.0 s	See chapter 2.3.4
29h	Channel error mask	bit	16 bit	See chapter 5.4.7 on page 57	0 = none	See chapter 2.8.11 on page 25
2Ah	Group error mask	bit	16 bit	See chapter 5.4.8 on page 57	0 = none	See chapter 2.8.12 on page 25
Device Specification (further PIs are given in chapter 5.5 on page 58)						
32h	Device control	bit	8 bit	See chapter 5.5.3 on page 58	0 = ° C	See chapter 2.10 on page 28
33h	Sensor type	-	8 bit	See chapter 5.5.2 on page 58	0 = type J	See chapter 2.1.2 on page 6
36h	Limit value configuration	bit	8 bit	See chapter 5.5.4 on page 58	0 = none	See chapter 2.8.3 on page 22
37h	Output configuration	I/O	1 ... 16	See chapter 5.5.5 on page 59	8-chan. 3-step	
	continuous		1 ... 4			
38h	Output configuration	I/O	17 ... 24	See chapter 5.5.5 on page 59	0 = off	
3Ah	Power limitation	%	± 7 bit	0 ... +100 %	0 = off	See chapter 2.2.5
Heating Current Monitoring						
60h	Nominal heating current	0.1 A	± 15 bit	0.0 = off, 0.1 ... 1000.0 A	0 = off	See chapter 2.8.6 on page 23
61h	Heating current nominal value 2 nd controller	0.1 A	± 15 bit	0.0 = off, 0.1 ... 250.0 A	0 = off	
62h	Heating current nominal value 3 rd controller	0.1 A	± 15 bit	0.0 = off, 0.1 ... 250.0 A	0 = off	
64h	Summation current transformation ratio	0.1 A	± 15 bit	0.0 ... 1000.0 A	100.0 A	
67h	Heating current sampling cycle	0.1 s	± 15 bit	0.0 = auto, 0.1 ... 3000.0 s	0 = Auto	
69h	Secondary heating voltage	0.1 V	± 15 bit	0.0 = off, 10.0 ... 50.0 V	0 = off	
Data logger (further PIs are given in chapter 5.7 on page 60)						
92h	Logger sampling cycle	0.1 s	± 15 bit	0.1 ... 600.0 s	1.0 s	

¹⁾ MRL = measuring range lower limit, MRU = measuring range upper limit, MRS = measuring range span

¹⁾ The parameter units which refer to the measured values depend on the **actual value factor** in the 10 V / 20 mA version, compare chapter 2.3.6

3 RS 232 Service Interface with Protocol per EN 60870

3.1 General

Interface connection is described in a separate set of installation instructions.

3.1.1 Interface Configuration

The controller is equipped with a serial interface with the following configuration:

- Modes RS-232 (2-wire)
- Baud rate 19,200 Bd
- Fformat 8 data bit, 1 parity bit, 1 stop bit
- Parity even
- Device address fixed at 3

3.1.2 Communication Protocol

The data transmission protocol per EN 60870 is used for communication between the field control level and the device level. Only a sub-group of the functions defined by this protocol is utilized by the controller.

3.1.3 Primary Function

A master-slave protocol is used with a permanently assigned master (master computer) and up to 255 slaves (devices).

Communication takes place in the half-duplex operating mode, i.e. a device connected to the master computer only becomes active (responds):

- If it receives a valid frame addressed to itself
- If the specified maximum response delay time (t_{rd}) has expired, allowing the master computer enough time to become ready to receive

The master computer may not become active again until:

- It receives a valid response frame from the addressed device and the specified waiting period after completion of the response frame (t_{rw}) has expired
- The specified maximum response delay time (t_{rd}) has expired
- The specified character delay time has expired (t_{cdt} = pause between 2 character transmissions). This waiting time also applies for the receipt of invalid and incomplete responses!

3.1.4 Time Response

Ready to transmit/receive after power-up	t_{rdy}	approx. 5 s
Character delay time (instrument)	t_{cdt}	< 3 ms
Character delay time (master)	t_{cdm}	< 100 ms
Response delay time (instrument)	t_{rd}	< 10 ... 100 ms
Query waiting time after response (master)	t_{rw}	> 10 ms

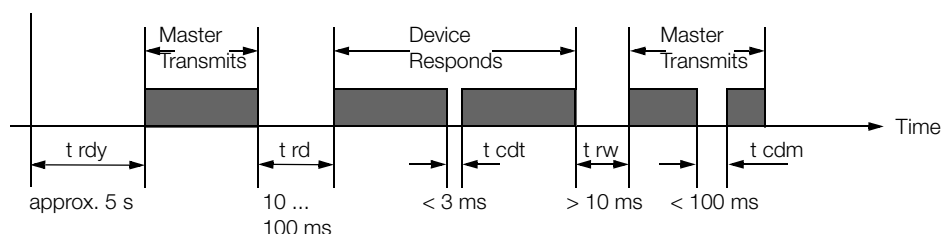

Figure 6 Basic Time Response

3.2 Frame Types and Layout

In both the query and the response direction, all frames consist of one of three string types which differ in their basic structure. Their use is required for all interface functions made available by the controller, and they are described as follows.

3.2.1 Short Strings

Short strings are used

by the querying device:

- For the transmission of short commands to devices (e.g. “reset” etc.)
- For abbreviated querying of important data from the devices (e.g. events data etc.)

by the responding device:

- To acknowledge queries which do not require response

Basic Short String Layout

Character No.	Content	Meaning	Comment
1	10h	Start message character (SMC)	
2		Function field (FF)	See chapter 3.2.4 on page 33
3		Device address (DA)	
4		Checksum (CS)	See chapter 3.2.4 on page 33
5	16h	End message character (EC)	

3.2.2 Control Strings

Control strings are only used by the querying device. They are used to query all devices which cannot be queried with short strings, because they require a complete specification.

Basic Control String Layout

Character No.	Content	Meaning	Comment
1	68h	Start message character (SC1)	
2		Length (L1)	Number of characters from function field up to but not including the checksum
3		Length (repetition) (L2)	
4	68h	Start message character (repetition) (SC2)	
5		Function field (FF)	See chapter 3.2.4 on page 33
6		Device address (DA)	
7		Parameters index (PI)	See chapter 3.2.4 on page 33
8		From channel (fC)	See chapter 3.2.4 on page 33 These characters are not included in some parameters indices from main group 3.
9		To channel (tC)	
10	00h	Recipe number (RN)	
8 or 11		Checksum (CS)	See chapter 3.2.4 on page 33
9 or 12	16h	End message character (EC)	

3.2.3 Long String

Long strings are used:

- to transmit commands and parameters to a device
- to receive data and parameters from a device

Basic Long String Layout

Character No.	Content	Meaning	Comment
1	68h	Start message character (SC1)	
2		Length without SC1, L1, L2, SC2, CS, EC (L1)	Number of characters from function field up to but not including the checksum
3		Length (repetition) (L2)	
4	68h	Start message character (repetition) (SC2)	
5		Function field (FF)	See chapter 3.2.4 on page 33
6		Device address (DA)	
7		Parameters index (PI)	See chapter 3.2.4 on page 33
8		From channel (fC)	See chapter 3.2.4 on page 33 These characters are not included in some parameters indices from main group 3.
9		To channel (tC)	
10	00h	Recipe number (RN)	
		n characters of user data	
L1 + 5		Checksum (CS)	See chapter 3.2.4 on page 33
L1 + 6	16h	End message character (EC)	

3.2.4 Format Character Function and Value Range

Device Address (DA)

- 3 The device address is fixed at 3.
- 255 This address can be used to contact all devices connected to the bus simultaneously. Data and commands transmitted to this address are accepted by all devices, and no acknowledgement is transmitted to the master.

Length (L1, L2)

Length entries L1 = L2 make reference to the number of characters from the function field (FF) up to but not including the checksum (CS), and are used in control strings and long strings. L1 and L2 are independent of the utilization of fC, tC and RN, and the number (n) of user data characters.

Correspondingly, L1 and L2 have a

- value of 3 or six in control strings and
- a value of n + 3 or n + 6 in long strings.

Function Field (FF)

The function field includes

- actual user information in short strings – its function is predefined bit by bit, and is different in the query and response directions,
- direction and control information for transmitted user data in control strings and long strings.

Function Coding for the Function Field in the Query Direction

Query Control	Code	String	Comment
Standardize data layer link	40h	Short string	Only the indicated codes are evaluated, invalid codes are responded to with an error acknowledgement.
Reset device	44h		
Query: "device OK?"	49h		
Request events data	7Ah		
Request cycle data	7Bh		
Request heating currents	7Eh	Long string	
Transmit data to controller	73h		
Request data from controller	7Bh		

Function Coding for the Function Field in the Response Direction

Bit no.	Function	Value	Meaning	
0 ... 3	Response	0	ACK: positive acknowledgement	Short string
		1	NACK: negative acknowledgement; message not accepted	
		B	Response to: "device OK?"	
		8	Transmit data	Long string
4	Job acknowledgement	0	Job executed, device ready	
		1	Device not ready for this job, repeat job if required	
5	Service request	0	No error	
		1	Error occurred (query events data)	
6	Direction bit	0		
7	—	0		

Parameters Index (PI)

The type of data to be transmitted is determined with the parameters index. The "PI" character is interpreted as follows:

Bits 7 ... 4	Bits 3 ... 0
0 ... Fh	0 ... Fh
Selection number for main parameters group	Selection number for special parameters

Functionally related data and setting parameters for a given device are included in the main parameters groups. Only those parameters indices which are documented in chapter 5 on page 51 can be accessed, all others are acknowledged with an error message.

Channel and Recipe Selection (fC, tC, RN)

Due to the fact that the controller is a multi-channel device, the entries

"from channel" fC
 "to channel" tC

are used to determine which channels will transmit the requested data. The entry fC = 0 and tC = 0 indicates that all channels will be used.

Data can be requested from various parameter sets with the recipe number (RN). The controller includes only one recipe (RN = 0).

Checksum (CS)

The checksum consists of a byte-by-byte summation (without overflow summation) including all characters from the function field (FF), up to but not including the checksum (CS) for all string types.

Example: short string: CS = FF + DA

Length and Structure of User Data Blocks

Length and structure are variable, and depend upon PI, fC and tC.

Transmitted values may be structured according to bytes or words. the following formats are used:

±7 bit	Representation as 2 part compliment	Number with plus or minus sign
±15 bit	LS byte first, representation as 2 part compliment	Number with plus or minus sign
8 bit	LS byte first	Bit field

3.2.5 Criteria for the Validity of a Query Frame

If criteria are fulfilled, the controller responds with the requested data:

- No parity error in the query frame or in the response frames of other bus users.
- For short strings:

Character	Content	Meaning	Comment
1	10h	SMC	
2	40h 44h 49h 7Ah 7Bh 7Eh	FF	Valid function coding: Standardize data layer link Reset Device OK? Event Cycle Heating currents
3	0 ... 255	DA	
4	(DA) + (FF)	CS	
5	16h	EC	

- For control strings and long strings:

Character	Content	Meaning	Comment
1	68h	SC1	
2		L1	
3	L1	L2	
4	68h	SC2	
5	73h 7Bh	FF	Write Read
6	0 ... 255	DA	Interface address
7		PI	Valid value
...		Data	
L1 + 5 th character		CS	Sum of FF up to and including data
L1 + 6 th character	16h	EC	

Exceptions, no response in the event of:

- Reset short string
- DA = 255 (broadcast address)

If incorrect FF, PI or CS data are received by the master computer, the controller responds with a short string with negative acknowledgement NACK.

If an error occurs at the controller (any bit set for device error or channel error), the controller responds with a short string in which the service request bit is set.

3.3 Frame Contents

3.3.1 Reset Device

The addressed device performs a hardware reset (same as for brief interruption of auxiliary power).

Example: device address = 2

Command (short string):

Character No.	Content	Meaning
1	10h	SMC
2	44h	FF (reset device)
3	02h	DA
4	46h	CS
5	16h	EC

Response:

	None, because reset is executed
--	---------------------------------

3.3.2 Query: Device OK?

The addressed device transmits the function field only.

Example: device address = 3

Command (short string):

Character No.	Content	Meaning
1	10h	SMC
2	49h	FF (device OK?)
3	03h	DA
4	4Ch	CS
5	16h	EC

Response (short string):

Character No.	Content	Meaning
1	10h	SMC
2	0Bh	FF (e.g. no error occurred)
3	03h	DA
4	0Eh	CS
5	16h	EC

3.3.3 Cycle Data

The most important controller measurement and evaluation data are contained in a single data packet. Cyclical queries for these values are thus possible in compact form (short string command query).

Example: device address 3

Command (short string):

Character No.	Content	Meaning
1	10h	SC
2	7Bh	FF
3	03h	DA
4	7Eh	CS
5	16h	EC

Response (long string):

Character No.	Content	Meaning	U/M	Format	Comment
1	69h	SC1			
2	2Ch	L1			Number of characters from character 5 ... 48
3	2Ch	L2			
4	68h	SC2			
5	08h	FF			(e.g. no error)
6	03h	DA			
7, 8			0.1 °	± 15 bit	Momentary controlled variable, channel 1
...			0.1 °
21, 22			0.1 °	± 15 bit	Momentary controlled variable, channel 8
23			%	± 7 bit	Momentary manipulated variable, channel 1
...			%
30			%	± 7 bit	Momentary manipulated variable, channel 8
31, 32			0.1 A	± 15 bit	Momentary heating current, channel 1
...			0.1 A
45, 46			0.1 A	± 15 bit	Momentary heating current, channel 8
47, 48			0.1 V	± 15 bit	Momentary heating voltage
49		CS			
50	16h	EC			

3.3.4 Heating Current Data

These data include heating current for the 2nd and 3rd controllers in one data packet (see also chapter 2.8.6 on page 23, monitoring 16/24 channels).

Example: device address 3

Command (short string):

Character No.	Content	Meaning
1	10h	SZ
2	7Eh	FF
3	03h	GA
4	81h	PS
5	16h	EZ

Response (long string):

Character No.	Content	Meaning	U/M	Format	Comment
1	69h	SZ1			
2	22h	L1			Number of characters from character 5 ... 38
3	22h	L2			
4	68h	SZ2			
5	08h	FF			(e.g. no error)
6	03h	GA			
7, 8			0.1 A	± 15 bit	Momentary heating current channel 1, 2 nd controller
...			0.1 A
21, 22			0.1 A	± 15 bit	Momentary heating current channel 8, 2 nd controller
23, 24			0.1 A	± 15 bit	Momentary heating current channel 1, 3 rd controller
...			0.1 A
37, 38			0.1 A	± 15 bit	Momentary heating current channel 8, 3 rd controller
39		PS			
40	16h	EZ			

3.3.5 Events Data

Events data include all error messages and alarms generated by the device. They can be queried by means of a short string for the identification of a specific error alarm, for example if the BA bit (group error) was previously set in the function field (FF) of any given response frame.

Example: device address 3:

Command (short string):

Character No.	Content	Meaning
1	10h	SC
2	7Ah	FF
3	03h	DA
4	7Dh	CS
5	16h	EC

Response (long string):

Character No.	Content	Meaning	U/M	Format	Comment
1	68h	SC1			
2	1Ah	L1			Number of characters from character 5 ... 30
3	1Ah	L2			
4	68h	SC2			
5	28h	FF			(e.g. bit 6 = 1, one or several errors)
6	03h	DA			
7, 8			Bit	16 bit	Error status, channel 1
...			Bit
21, 22			Bit	16 bit	Error status, channel 8
23, 24			Bit	16 bit	Device error status
25			Bit	8 bit	Output error 1
...			Bit
30			Bit	8 bit	Output error 6
31		CS			
32	16h	EC			

Bit assignments for the error status word and the output error are described in chapter 5.4.3 on page 55.

3.3.6 Requesting Data from the Controller

All values, parameters, configurations, statuses, device IDs etc. can be queried with this type of communication.

Data are queried individually per parameters index. A complete list of all parameters indices is included in chapter 5 on page 51.

Querying a Device Specification

The parameters index is in main group 3. The characters “from / to channel” and “recipe number” are thus omitted for some parameters indices in control strings and long strings.

Example: Read device characteristic from device no. 3

Query (control string without fC, tC, RN):

Character No.	Content	Meaning
1	68h	SC1
2	03h	L1
3	03h	L2
4	68h	SC2
5	7Bh	FF (e.g. = 7Bh: read data)
6	03h	DA (e.g. = 3)
7	31h	PI (e.g. = 31h: device characteristic)
8	AFh	CS
9	16h	EC

Response (long string without fC, tC, RN):

Character No.	Content	Meaning
1	68h	SC1
2	04h	L1
3	04h	L2
4	68h	SC2
5	08h	FF (e.g. = 08h: no error)
6	03h	DA
7	31h	PI
8	08h	Device characteristic = 08h
9	44h	CS
10	16h	EC

Requesting, for Example, a Control Parameter

The parameters index is not part of main group 3, and the characters “from / to channel” and “recipe number” are thus included in control strings and long strings.

Example: Read sensor error manipulating factor from device no. 3, channel 1, value = 20%

Command (control string):

Character No.	Content	Meaning
1	68h	SC1
2	06h	L1
3	06h	L2
4	68h	SC2
5	7Bh	FF (e.g. = 7Bh: read)
6	03h	DA (e.g. = 3)
7	1Eh	PI (e.g. = 1Eh: sensor error manipulating factor)
8	01h	fC
9	01h	tC
10	00h	RN
11	9Eh	CS
12	16h	EC

Response (long string):

Character No.	Content	Meaning
1	68h	SC1
2	07h	L1
3	07h	L2
4	68h	SC2
5	08h	FF (e.g. = 08h: = no error)
6	03h	DA (e.g. = 3)
7	1Eh	PI (e.g. = 1Eh: sensor error manipulating factor)
8	01h	fC
9	01h	tC
10	00h	RN
11	14h	Information field where n = 1 character
12	3Fh	CS
13	16h	EC

3.3.7 Transmitting Data to the Controller

All parameters, configurations and operating states can be set with this type of communication. Data are queried individually per parameters index.

A complete list of all parameters indices is included in chapter 5 on page 51.

The setting range of the transmitted value is checked by the controller. If the value is not within the allowable range, it is not saved to memory. In the event of an error, the “parameter error” bit is set, and the “service request” bit is set in the function field of the acknowledgement short string.

Complete configuration must be performed before parameters are set, because the configuration effects usage and the setting ranges of individual “temperature parameters”.

Transmitting a Device Specification

The parameters index is in main group 3. The characters “from / to channel” and “recipe number” are thus omitted for some parameters indices in control strings and long strings.

Example: Set controlled variable quantity at device no. 3 to °F

Command (long string):

Character No.	Content	Meaning
1	68h	SC1
2	04h	L1
3	04h	L2
4	68h	SC2
5	73h	FF (read data)
6	03h	DA (= 3)
7	32h	PI
8	01h	Value
9	A9h	CS
10	16h	EC

Response (short string):

Character No.	Content	Meaning
1	10h	SMC
2	00h	FF (no error)
3	03h	DA
4	03h	CS
5	16h	EC

Transmitting, for Example, a Temperature Parameter

The parameters index (PI) is not part of main group 3, and the characters “from / to channel” and “recipe number” are thus included in long strings.

Example: Transmit setpoint = 25.0° to device no. 3, channel 3

Command (long string):

Character No.	Content	Meaning
1	68h	SC1
2	08h	L1
3	08h	L2
4	68h	SC2
5	73h	FF (e.g. = 73h: transmit data)
6	03h	DA (e.g. = 3)
7	00h	PI (e.g. = 00h: setpoint)
8	03h	fC
9	03h	tC
10	00h	RN
11, 12	FAh, 00h	Information field where n = 2 characters, format: ± 15 bit, LSB first
13	72h	CS
14	16h	EC

Response (short string):

Character No.	Content	Meaning
1	10h	SC
2	10h	FF (e.g. device not ready for job)
3	03h	DA
4	13h	CS
5	16h	EC

4 Communication via Backplane Bus

4.1 General

Peripheral addresses are determined in the same way as for an analog module; in the case of fixed addressing, the initial address is $256 + n \times 16$.

From a total of 16 addresses, the first 12 are used for exchanging temperature values, parameters etc., and the rest are used for the cyclical exchange of binary input and output statuses.

The communications layout is the same for the 4-channel variant; parameters and values for channels 5 through 8 are ignored, or are "0".

Data Exchange Peripheral output / CPU → R355

Addr. Offset	Content	Format	Content
0	FF	8 bit	Function field
1	PI	8 bit	Block number
2, 3	CS	16 bit	Checksum
4 ... 11			Data
12 ... 14		8 bit	Desired status for binary I/Os 1 ... 24
15			not in use

Data Exchange Peripheral input / R355 → CPU

Addr. Offset	Content	Format	Content
0	FF	8 bit	Function field
1	PI	8 bit	Block number
2, 3	CS	16 bit	Checksum
4 ... 11			Data
12 ... 14		8 bit	Actual status for binary I/Os 1 ... 24
15			not in use

4.2 Exchange of Binary I/O Data

- Binary I/O data are exchanged continuously, and statuses are transferred or updated every 10 ms (R355 internal cycle).
- This makes read-back of actual I/O statuses and the control of free outputs possible for the controller module with I/Os.
- The binary signals are read for forwarding to the actuators and for regulating control functions in the case of the controller module without I/Os.

Controlling Free I/Os Peripheral output / CPU → R355

Addr. Offset	U/M	Format	Content
12	Bit	8 bit	Desired status for binary I/Os 1 ... 8
14	Bit	8 bit	Desired status for binary I/Os 9 ... 16
15	Bit	8 bit	Desired status for binary I/Os 17 ... 24

- The desired statuses are only accepted by the variant with I/Os if the outputs are configured as free outputs (PI = 37h, 38h: value = 40h).
- The desired statuses are used as binary input statuses for the variant without I/Os.

Read In I/O Statuses Peripheral input / R355 → CPU

Addr. Offset	U/M	Format	Content
12	Bit	8 bit	Actual status for binary I/Os 1 ... 8
14	Bit	8 bit	Actual status for binary I/Os 9 ... 16
15	Bit	8 bit	Actual status for binary I/Os 17 ... 24

- The actual I/O statuses are transferred for the variant with I/Os.
- The binary I/Os can only be used as free inputs if they are correspondingly configured (PI = 37h, 38h: value = 81h); an I/O error would otherwise be indicated.
- The output statuses which would be accepted by a controller with I/Os are transferred for the variant without I/Os.

4.3 Exchange of Measured Values, Parameters and Configurations

The first two addresses (function field and block number) are used to control transmission, in order to exchange the great variety of data for the 8 controller channels and the controller module in a targeted fashion.

Data are only accepted or transferred when the write or read request (toggle bits) is written.

Data Exchange Periphery output / CPU → R355

Addr. Offset	Content	Format	Content
0	FF	8 bit	Function field
1	BL	8 bit	Block number
2, 3	CS	16 bit	Word checksum via addr. offset 0. 4 ... 10
4 ... 11			Data to be written

Data Exchange Periphery input / R355 → CPU

Addr. Offset	Content	Format	Content
0	FF	8 bit	Function field
1	BL	8 bit	Block number
2, 3	CS	16 bit	Word checksum via addr. offset 0. 4 ... 10
4 ... 11			Read data

General Remarks

- The quantities are selected per block number.
4 quantities of a channel (and/or the device) are combined per block.
The quantities are (with a few exceptions) in 16 bit format, 8 bit quantities are extended accordingly.
- The R355 proposes the latest data blocks for the reading operation.
- Read-back of the data to be written is identical to the writing operation, with the read request being set in the function field (bit 2 = 1).
- Communication is started by writing on block FFh. The time, the channels which are to communicate and a command byte are written.
Subsequently, the controller transmits the parameter set ID and the device version (block FFh).
At command byte = 1, all the parameters of the channels which are allowed to communicate are then listed so that the controller settings are transmitted to the data modules.
- Writing and reading of parameter sets is controlled with blocks FEh and FDh. The complete configuration and parameter setting of a module is transmitted in the process.

4.3.1 Function Field

The function field controls the reading and writing operation. The R355 only reacts at the moment the read or write toggle bit is changed. This means that the block number and the data always have to be written first, and finally the function field.

Function field (addr. offset 0)

Periphery output / CPU -> R355

Bit	Function	Value	Meaning
0, 1	FC function code	0 1 2, 3	no function data exchange reserved
2	Request	0 / 1	1 = read request instead of write request
3	—	0 / 1	not in use
4	Acknowledge	0 / 1	1 = data to be read accepted
5	—	0 / 1	not in use
6	S toggle	0 / 1	When status changes, new data to be written are available.
7	L toggle acknowledgement	0 / 1	When status is identical to the one that has been set in periphery input and acknowledge bit, the reading data have been accepted. At the same time, this is the request for the R355 to create new reading data.

Function field (addr. offset 0)

Periphery output / R355 -> CPU

Bit	Function	Value	Meaning
0, 1	FC function code	0 1 2, 3	no function data exchange reserved
2	Request	0 / 1	same value as CPU -> R355
3	—	0 / 1	not in use
4	Acknowledge	0 / 1	1 = data to be written accepted 0 = data to be written not accepted, no S toggle acknowledgement
5	—	0 / 1	not in use
6	S toggle acknowledgement	0 / 1	When status is identical to the one in periphery output, the data have been accepted from the R355
7	L toggle	0 / 1	When status changes, new data to be read by the R355 are available.

4.3.2 Block Number

- The content of the blocks to be written can be defined by the operator, in the form of a table each of 52 parameter indices for the channel blocks and 44 for the device blocks. Parameter index PI = FFh at the first place of a block defines the end of the blocks, followed by a blank word at the second to fourth place.
- During writing on blocks the content of which has been defined by parameter indices, the parameters are monitored with respect to their setting limits. If a parameter is not accepted, the error bit „Impermissible parameter“ is set. This bit must be acknowledged in the error status.
- The content of the blocks to be read and those which are intended for controlling the process (block No. FXh) is fixed.

4.3.3 Checksum

To secure transmission, the word checksum (Exor coupling) of periphery words 0, 4, 6, 8 and 10 is entered in the periphery word with offset 2. If the checksum is incorrect, the acknowledge bit is deleted by the receiving end without changing the toggle bit.

4.3.4 Data Block Format

The quantities to be transmitted are transmitted in one word each time (16 bit). The layout depends on the respective parameter index (PI).

Format	Interpretation	Value Range	MSB
8 bit	bit field, positive number	0 ... 255	0
±7 bit	number	-128 ... 127	supplemented by plus or minus sign
16 bit	bit number	(0 ... 65535)	—
±15 bit	number	-32768 ... 32767	—
BCD	2 BCD numbers	2 times 0 ... 99	—

4.3.5 Pre-defined Blocks

Device Blocks

- When remapping the device blocks please make sure that the parameter indices with several words are always placed at the beginning of a block in order to fill the block in a consecutive manner.
- The output configuration is not included with the blocks as a standard feature.
- Use block FFh to set the time.
- Reading blocks 90 and 91 are not updated before the content changes or communication is started.
- No other quantities can be mapped to the block contents identified with „fix“.

Block	Word	fix	PI	Value
				Read only
90	0	X	21	Device error status (actual)
	1	X	21	I/O error
	2	X	21	I/O error
	3	X	21	I/O error
91	4	X	26	Master actual value group 0
	5	X	26	group 1
	6	X	26	group 2
	7	X	B3	Reference junction temperature
				Write
92	8	X	21	Device error status (acknowledgement)
	9	X	32	Device control (commands only)
	10	X	32	Device control (settings only)
	11		FF	—
93	12	X	3F	Parameter set ID in BCD s, min
	13	X	3F	h, d
	14	X	3F	mon, y
	15	X	31/35	Device characteristic / firmware version
94	16		30	Device ID
	17		35	Software version
	18		92	Logger sampling cycle
	19		93	Logger control
95	20		64	Summation current transformer ratio
	21		69	Secondary heating voltage
	22		67	Heating current sampling cycle
	23		3A	Power limitation
96	24		2A	Group error mask A
	25		2A	B
	26		2A	C
	27		2A	D
97	28		2A	Group error mask E
	29		2A	F
	30		2A	G
	31		2A	H
98	32		26	Master actual value group 0
	33		26	group 1
	34		26	group 2
	35		FF	—

Channel blocks

- The 4 bits at the top of the block number constitute the channel number.
- Blocks X0 and X1 are only read. Block X0 is updated every 100 ms per channel. Block X1 is not updated before the content changes or communication is started.
- No other quantities can be mapped to the block contents identified with „fix“.
- Block X4 is transmitted automatically upon conclusion of self-optimization. The handling modules should take this into account to avoid overwriting the established values.
- The same applies to the block which contains the heating current nominal value (e. g. X7) after the automatic determination of the heating current nominal values has been initiated.

Block	Word	fix	PI	Value
1X...8X				Read only
X0	0	X	B1	Momentary actual value
	1	X	B7	Momentary manipulating factor
	2	X	21	Error status (actual)
	3	X	24	Controller status
X1	4	X	20	Controller function (actual)
	5	X	B0	Momentary setpoint
	6	X	6C	Heating current actual value
	7	X	6F	Heating voltage actual value
				Write
X2	8	X	20	Controller function (setpoint)
	9	X	00	Setpoint
	10	X	21	Error status (acknowledgement)
	11		03	Proxy setpoint
X3	12		28	Manual manipulating factor
	13		27	External actual value
	14		07	Maximum setpoint
	15		06	Minimum setpoint
X4	16	X	10	Proportional band heating (Xpl)
	17	X	11	Proportional band cooling (Xpll)
	18	X	14	System delay (Tu)
	19	X	15	Cycle time
X5	20		01	First upper limit value
	21		02	First lower limit value
	22		04	Second upper limit value
	23		05	Second lower limit value
X6	24		0E	Setpoint ramp, up
	25		0F	Setpoint ramp, down
	26		12	Dead zone
	27		1F	Switching hysteresis
X7	28		1D	Maximum manipulating factor
	29		1C	Minimum manipulating factor
	30		18	Motor manipulating factor
	31		60	Heating current - nominal value
X8	32		16	Actuator manipulating factor
	33		17	Actuation manipulating factor
	34		19	Influencing quantity manipulating factor
	35		1E	Sensor error manipulating factor
X9	36		08	Setpoint rise (Boost)
	37		09	Boost duration
	38		0A	Actuation setpoint
	39		0B	Dwell time during actuation
A	40		33	Sensor type
	41		0C	Actual value correction
	42		0D	Actual value factor
	43		25	Oscillation hold-off
XB	44		22	Controller configuration
	45		23	Extended controller configuration
	46		29	Channel error mask
	47		36	Limit value configuration

Heating current monitoring blocks

These blocks are only active if heating current monitoring over 16 and/or 24 channels has been configured. (Compare chapter 2.8.6)

Block	Word	fix	PI	Value
				Read only
A0	0	X	6D	Heating current actual value 2 nd controller 1 st channel
	1	X	6D	2 nd channel
	2	X	6D	3 rd channel
	3	X	6D	4 th channel
A1	4	X	6D	Heating current actual value 2 nd controller 5 th channel
	5	X	6D	6 th channel
	6	X	6D	7 th channel
	7	X	6D	8 th channel
A2	8	X	6E	Heating current actual value 3 rd controller 1 st channel
	9	X	6E	2 nd channel
	10	X	6E	3 rd channel
	11	X	6E	4 th channel
A3	12	X	6E	Heating current actual value 3 rd controller 5 th channel
	13	X	6E	6 th channel
	14	X	6E	7 th channel
	15	X	6E	8 th channel
				Write
A4	16	X	61	Heating current nominal value 2 nd controller 1 st channel
	17	X	61	2 nd channel
	18	X	61	3 rd channel
	19	X	61	4 th channel
A5	20	X	61	Heating current nominal value 2 nd controller 5 th channel
	21	X	61	6 th channel
	22	X	61	7 th channel
	23	X	61	8 th channel
A6	24	X	62	Heating current nominal value 3 rd controller 1 st channel
	25	X	62	2 nd channel
	26	X	62	3 rd channel
	27	X	62	4 th channel
A7	28	X	62	Heating current nominal value 3 rd controller 5 th channel
	29	X	62	6 th channel
	30	X	62	7 th channel
	31	X	62	8 th channel

Alarm History Blocks

- Writing on block B4h activates the reading of the blocks, and all 5 blocks are read out in the process.
- As described in chapter 2.9.4 on page 28, read-out is controlled by the read-out starting point.
- When a value greater than zero is entered at the read-out starting point, this value is adopted and the associated history entry is given out. If the entered value exceeds the number of entries, it is placed at the beginning of the record.
- When the value zero is entered at the read-out starting point, the history entry associated with the current read-out starting point is given out.
- When the value -1 is entered at the read-out starting point, the read-out starting point is decremented and the associated history entry is given out.
- If the returned read-out starting point equals one, the last entry has been read out.
- If the returned read-out starting point equals zero, there are no entries.

Block	Word	fix	PI	Value
				Read only
B0	0	X	2F	Number of entries alarm history
	1	X	2C	Alarm history, time stamp s, min
	2	X	2C	h, d
	3	X	2C	mon, y
B1	4	X	2E	Alarm history 1 st channel
	5	X	2E	2 nd channel
	6	X	2E	3 rd channel
	7	X	2E	4 th channel
B2	8	X	2E	Alarm history 5 th channel
	9	X	2E	6 th channel
	10	X	2E	7 th channel
	11	X	2E	8 th channel
B3	12	X	2E	Alarm history Device
	13	X	2E	I/O
	14	X	2E	I/O
	15	X	2E	I/O
				Write
B4	16	X	2D	Read-out starting point alarm history
	17	X	FF	
	18	X	FF	
	19	X	FF	

Logger Blocks

- Read-out of the logger is performed in the same way as the read-out of the alarm history. After an entry has been made in block C5h, all 6 blocks are given out. (compare also chapter 2.9.2 on page 26).
- Please note that (in contrast to the alarm history) the time stamp refers to the **last** sample and not to the one currently given out.

Block	Word	fix	PI	Value
				Read only
C0	0	X	98	Number of samples
	1	X	99	Time stamp of last sample
	2	X	99	s, min
	3	X	99	h, d
				mon, y
C1	4	X	96	Sampled actual values
	5	X	96	1 st channel
	6	X	96	2 nd channel
	7	X	96	3 rd channel
				4 th channel
C2	8	X	96	Sampled actual values
	9	X	96	5 th channel
	10	X	96	6 th channel
	11	X	96	7 th channel
				8 th channel
C3	12	X	97	Sampled manipulated variables
	13	X	97	1 st channel
	14	X	97	2 nd channel
	15	X	97	3 rd channel
				4 th channel
C4	16	X	97	Sampled manipulated variables
	17	X	97	5 th channel
	18	X	97	6 th channel
	19	X	97	7 th channel
				8 th channel
				Write
C5	20	X	94	Read-out starting point sampled actual values
	21	X	95	Read-out starting point sampled manipulated variables
	22	X	FF	
	23	X	FF	

Start block

- Block FFh is written to start communication.
The „current time“ (PI = 90h) can be set in this context.
- The bit pattern in the channel enabling function (byte 6) determines the channels to be read.
If no channel has been enabled (byte 6 = 0), those channels are read which are not configured as controller type = „not in use“.
- The reading block returns the parameter set ID and the device characteristic so that the exchange of a controller module is recognized.
- In command code = 1 (byte 7) alle enabled parameter blocks are read to allow for the data modules to receive the controller settings.

Block	Word	fix	PI	Value
				Read only
FF	0	X	3F	Parameter set ID in BCD s, min
	1	X	3F	h, d
	2	X	3F	mon, y
	3	X	31 / 35	Device characteristic / firmware version
				Write only
FF	0	X	90	current time in BCD s, min
	1	X	90	h, d
	2	X	90	mon, y
	3	X	--	Byte 6: channel enabling Byte 7: 0 -> only reading blocks are transmitted 1 -> all writing blocks are transmitted

4.3.6 Transmission of Parameter Sets

- A complete parameter set comprises 768 (300h) bytes.
The first 640 (280h) bytes contain the entire configuration and parameter setting of a module, with the last 2 bytes serving as CRC16 check.
The following 44 bytes contain the defined device blocks, the next 52 bytes contain the defined channel blocks. The last 32 bytes are reserved.
- Writing in the R355 module can be done in any order whatever.
The written configuration and parameter setting (bytes 0...639) are activated and accepted by the module-internal EEPROM as soon as the 639th byte has been written and the CRC16 check has been successfully completed.
The parameters contained are not checked for their setting limits. The CRC16 check serves as a safeguard as it ensures that the parameter set is derived from a controller or a configuration tool.
- The definition of the device and channel blocks (bytes 640...767) is accepted on writing the last byte.
- Read-out of the parameter set is initiated by writing on block FDh.
In order to obtain the momentary settings, reading has to be started from address 0.
The R355 module then supplies 128 blocks (768 bytes) of the active parameter set.

Block	Word	fix	PI	Value
				Write only
FD	0	X	—	Initial data address (normal = 0)
	1	X	—	not in use
	2	X	—	not in use
	3	X	—	not in use
				Read and write
FE	0	X	—	Data address
	1	X	—	Parameter set content
	2	X	—	Parameter set content
	3	X	—	Parameter set content

5 Device Parameters

5.1 Overview

Channel-specific Quantities

Main Group	PI	Value	Format	fC, tC, PN	Number	Comment	
0		Temperature Parameters					
	00	Setpoint	± 15 bit	✓	8		
	01	First upper limit value	± 15 bit	✓	8		
	02	First lower limit value	± 15 bit	✓	8		
	03	Proxy setpoint	± 15 bit	✓	8		
	04	Second upper limit value	± 15 bit	✓	8		
	05	Second lower limit value	± 15 bit	✓	8		
	06	Minimum setpoint	± 15 bit	✓	8		
	07	Maximum setpoint	± 15 bit	✓	8		
	08	Setpoint rise (Boost)	± 15 bit	✓	8		
	09	Boost duration	± 15 bit	✓	8		
	0A	Actuation setpoint	± 15 bit	✓	8		
	0B	Dwell time (during actuation)	± 15 bit	✓	8		
	0C	Actual value correction	± 15 bit	✓	8		
	0D	Actual value factor	± 15 bit	✓	8		
	0E	Setpoint ramp, up	± 15 bit	✓	8		
	0F	Setpoint ramp, down	± 15 bit	✓	8		
1		Control Parameters					
	10	Proportional zone heating (Xpl)	± 15 bit	✓	8		
	11	Proportional zone cooling (Xpll)	± 15 bit	✓	8		
	12	Dead zone	± 15 bit	✓	8		
	14	System delay (Tu)	± 15 bit	✓	8		
	15	Cycle time	± 15 bit	✓	8		
	16	Actuator manipulating factor	± 7 bit	✓	8		
	17	Actuation manipulating factor	± 7 bit	✓	8		
	18	Motor actuation time	± 15 bit	✓	8		
	19	Influencing quantity manipulating factor	± 7 bit	✓	8		
	1C	Minimum manipulating factor	± 7 bit	✓	8		
	1D	Maximum manipulating factor	± 7 bit	✓	8		
	1E	Sensor error manipulating factor	± 7 bit	✓	8		
	1F	Switching hysteresis	± 15 bit	✓	8		
2		Control Commands					
	20	Controller function	8 bit	✓	8		
	21	Error status	16 bit	✓	12	Words 1 ... 8 are channel-specific	
	22	Controller configuration	16 bit	✓	8		
	23	Expanded controller configuration	8 bit	✓	8		
	24	Controller status, message word	16 bit	✓	9	Read only	
	25	Oscillation hold-off	8 bit	✓	8		
	27	external actual value	± 15 bit	✓	8		
	28	Manual manipulating factor	± 7 bit	✓	8		
	29	Channel error mask	16 bit	✓	8		
3		Device Specifications					
	33	Sensor type	8 bit	✓	8		
	36	Limit value configuration	8 bit	✓	8		
6		Heating Current Monitoring					
	60	Nominal heating current	± 15 bit	✓	8		
	6C	Heating current - actual value	± 15 bit	✓	8	Read only	
B		Display Values					not via service interface
	B0	Momentary setpoint	± 15 bit	✓	8	Read only	
	B1	Momentary actual value	± 15 bit	✓	8	Read only	
	B2	Momentary system deviation	± 15 bit	✓	8	Read only	
	B7	Momentary manipulating factor	± 15 bit	✓	8	Read only	
	B8	Momentary setpoint (whole degrees)	± 15 bit	✓	8	Read only	
	B9	Momentary actual value (whole degrees)	± 15 bit	✓	8	Read only	
	BA	Momentary system deviation (whole degrees)	± 15 bit	✓	8	Read only	

Device-specific Quantities

Main Group	PI	Value	Format	fC, tC, PN	Number	Comment
2		Control Commands				
	21	Error status	16 bit	✓	12	Words 9 ... 12 are device-specific
	26	Master actual value	± 15 bit	✓	4	
	2A	Group error mask	16 bit	✓	8	
3		Device Specifications				
	30	Device ID	8 bit		1	Read only
	31	Device characteristic	8 bit		1	Read only
	32	Device control	8 bit		1	
	35	Software version	8 bit		1	Read only
	37	Output configuration	I/O 1 ... 16 continuous output 1 ... 4	8 bit	✓	20
	38	Output configuration	I/O 17 ... 24	8 bit	✓	8
	3A	Power limitation	± 7 bit		1	
	3F	Parameter set ID	16 bit	✓	3	
6		Heating Current Monitoring				
	61	Heating current nominal value 2 nd controller	± 15 bit	✓	8	
	62	Heating current nominal value 3 rd controller	± 15 bit	✓	8	
	64	Summation current transformation ratio	± 15 bit	✓	1	
	67	Heating current sampling cycle	± 15 bit	✓	1	
	69	Heating voltage transformer secondary voltage	± 15 bit	✓	1	
	6D	Heating current - actual value 2 nd controller	± 15 bit	✓	8	Read only
	6E	Heating current - actual value 3 rd controller	± 15 bit	✓	8	Read only
	6F	Heating voltage - actual value	± 15 bit	✓	1	Read only
B		Display Values				
	B3	Reference junction temperature	± 15 bit	✓	1	Read only

Special functions

Main Group	PI	Value	Format	fC, tC, PN	Number	Comment
2		Control Commands				
	2C	Alarm history, time stamp	16 bit		3	Read only, not via service interface
	2D	Alarm history read-out starting point	± 15 bit		1	
	2E	Alarm history	16 bit	✓	15/12	Read only
	2F	Number of alarm history entries	± 15 bit		1	Read only
3		Device Specifications				
	3D	Block numbers	8 bit	✓	96	only via service interface
	3E	Parameter set transfer	8 bit		2 + 8	only via v bus
9		Data logger				
	90	Current time	16 bit	✓	3	No real-time clock
	92	Logger sampling cycle	± 15 bit		1	
	93	Logger control	8 bit		1	
	94	Read-out starting point sampled actual values	± 15 bit		1	
	95	Read-out starting point sampled manipulated variables	± 15 bit		1	
	96	Sampled actual values	± 15 bit	✓	(1 ... 15) x 8	Read only
	97	Sampled manipulated variables	± 15 bit	✓	(1 ... 15) x 8	Read only
	98	Number of samples	± 15 bit		1	Read only
	99	Time of last sample	16 bit	✓	3	No real-time clock
E		Control Functions				
	E1	State of continuous outputs	16 bit	✓	4	

All setting parameters and data are assigned to parameters groups according to functional relationships. Together with cycle data and events data, the controller can thus be operated entirely via the bus interface.

5.3 Main Group 1: Control Parameters

5.3.1 Table of Parameter Indices

PI	Parameter Designation	U/M	Format	Number	Setting Range	Comment
10h	Proportional zone heating	0.1°	± 15 bit	8	0 ... MRS ¹⁾	
11h	Proportional zone cooling	0.1°	± 15 bit	8	0 ... MRS ¹⁾	
12h	Dead zone	0.1°	± 15 bit	8	0 ... MRS ¹⁾	
14h	System delay	0.1 s	± 15 bit	8	0 ... 30000	
15h	Cycle time	0.1 s	± 15 bit	8	1 ... 3000	
16h	Actuator manipulating factor	%	± 7 bit	8	Min. ... max. manipulating factor	
17h	Actuation manipulating factor	%	± 7 bit	8	Min. ... max. manipulating factor	
18h	Motor actuation time	0.1 s	± 15 bit	8	10 ... 6000	
19h	Influencing quantity manipulating factor	%	± 7 bit	8	Min. ... max. manipulating factor	
1Ch	Minimum manipulating factor	%	± 7 bit	8	-100 ... 0	
1Dh	Maximum manipulating factor	%	± 7 bit	8	0 ... +100	
1Eh	Sensor error manipulating factor	%	± 7 bit	8	Min. ... max. manipulating factor	
1Fh	Switching hysteresis	0.1°	± 15 bit	8	0 ... MRS ¹⁾	

¹⁾ MRS = measuring range span

5.4 Main Group 2: Control Commands

5.4.1 Table of Parameter Indices

PI	Parameter Designation	U/M	Format	Number	Setting Range	Comment		
20h	Controller function	bit	8 bit	8	See chapter 5.4.2 on page 54			
21h	Channel error status	bit	16 bit	8	See chapter 5.4.3 on page 55	See events data		
	Device error status		16 bit	1				
	Output error		8 bit	6				
22h	Controller configuration	bit	16 bit	8	See chapter 5.4.4 on page 56			
23h	Expanded controller configuration	bit	8 bit	8	See chapter 5.4.5 on page 56			
24h	Controller status, message word	bit	16 bit	9	See chapter 5.4.6 on page 56	Read only		
25h	Oscillation hold-off	0.1 s	8 bit	8	0.0 = off, 0.3 ... 25.0 s			
26h	Master actual value	0.1°	± 15 bit	4	See chapter 2.6.3 on page 17			
27h	External actual value	0.1°	± 15 bit	8	See chapter 2.3.2 on page 9			
28h	Manual manipulating factor	%	± 7 bit	8	Min. ... max. manipulating factor	In manual mode only		
29h	Channel error mask	bit	16 bit	8	See chapter 5.4.7 on page 57			
2Ah	Group error mask	bit	16 bit	8	See chapter 5.4.8 on page 57			
2Ch	Alarm history, time stamp	-	16 bit	3	See chapter 5.4.9 on page 57	¹⁾ Read only, not via service interface		
2Dh	Alarm history read-out starting point	-	± 15 bit	1	1 ... 100	¹⁾		
2Eh	Alarm history	-	16 bit	3	See chapter 5.4.9 on page 57	¹⁾ Read only		
	Time stamp, via service interface only						16 bit	8
	Channel error status						16 bit	1
	Device error status						8 bit	6
2Fh	Number of alarm history entries	-	± 15 bit	1	1 ... 100	¹⁾ Read only		

¹⁾ For detailed description refer to chapter 2.9.4 on page 28

5.4.2 Controller Function

PI = 20h or function selection for control via binary input

Bit Number	Meaning	Comment
0	Proxy setpoint active	
1	Actuator circuit	
2	Feed-forward control	¹⁾
3	Temporary setpoint rise (Boost)	
4	Switching controller active	¹⁾
5	Clear error	¹⁾
6	Controller on	
7	Start self-tuning	see chapter 2.7.1

¹⁾ Device set deletes bit

5.4.3 Error Status

PI = 21h

Data are assigned just like events data.

The entry “from channel to channel” makes reference to 16 bit words, i.e.

Channel 1 ... 8	≅	channel error status 1 ... 8
Channel 9	≅	device error status
Channel 10 ... 12	≅	output error

Some errors must be acknowledged (compare tables):

This is accomplished by setting the corresponding error bits to 0. Transferred error status words (control loop, device) are linked to error status words in the controller, bit by bit, by means of AND logic, so that individual bits can be cleared in the error status word when errors are eliminated sequentially. Errors which occur during frame transmission are not cleared.

Bit Assignments for Channel Error Status

Bit Number	Meaning	Comment
0	Broken sensor	
1	Polarity reversal	
2	Second upper limit value exceeded	1) 3)
3	First upper limit value exceeded	1) 3)
4	First lower limit value fallen short of	1) 3)
5	Second lower limit value fallen short of	1) 3)
6	Impermissible parameter	2)
7	Heating current not off with deactivated actuating signal	
8	Too little heating current with active actuating signal	
9	Heating circuit error	2) 3)
10	Error starting adaptation	2) 3)
11	Adaptation error and abort	2) 3)
12	Too big heating current with active actuating signal	

1) Must be acknowledged in case of alarm memory

2) Must be acknowledged

3) Can be acknowledged via binary input

Bit Assignment for Device Error Status

Bit Number	Meaning	Comment
0	Analog component error, 24 V is missing	Error LED lights up
1	Overload, heating current 1	
2	Overload, heating current 2	
3	Overload, heating current 3	
4	Overload, heating voltage	
5	—	
6	Reference junction error	
7	EEPROM error	2) / error LED lights up
8	Group output error	Error LED lights up
9	Mapping error	2)
10	Parameter error	2)
11	Error in bus coupling	2) / Error LED lights up
12	24V error	
13	CRC error	2)

2) Must be acknowledged

Bit Assignment Output Error 1 ... 3

Bits are set although the output is short-circuited, i.e. when the output is active but no signal is present at the terminal.

Output Error 1	
Bit Number	Output
0 ... 7	1 ... 8

Output Error 2	
Bit Number	Output
0 ... 7	9 ... 16

Output Error 3	
Bit Number	Output
0 ... 7	17 ... 24

Bit Assignment Output Error 4 ... 6

Bits are set when the output is inactive, but a signal is present at the terminal.

Output Error 4	
Bit Number	Output
0 ... 7	1 ... 8

Output Error 5	
Bit Number	Output
0 ... 7	9 ... 16

Output Error 6	
Bit Number	Output
0 ... 7	17 ... 24

5.4.4 Controller Configuration

PI = 22h

Bit Number	Value	Meaning	Comment
0 ... 2	0 1 2 3 4, 5 6 7	Controller Type Channel not in use Measuring Actuator Limit transducer PDPI controller Proportional actuator Reserved	
3 ... 5	0 1 2 3 4 5 ... 7	Controller Class Fixed setpoint controller Differential controller Master controller Slave controller Switching controller Reserved	
6 ... 8	0 ... 7	Partner channel	For differential, slave and switching controllers
9, 10	0 1 ... 3	Group No group Group number	
11	0 / 1	Actual value control	off / on
12	0 / 1	Hot-runner	off / on
13	0 / 1	Water cooling	off / on
14	0 / 1	Adaptive measured value correction	off / on
15	0 / 1	Manual instead of off	off / on

5.4.5 Extended Controller Configuration

PI = 23h

Bit Number	Value	Meaning	Comment
0	0/1	internal / external actual value	
1	0/1	Actuating output normal / particularly for contactors	
2	0/1	Manual instead of boost on / off	compare chapter 2.5.3
3	0/1	D-component normal / attenuated	
4	0/1	PDPI- / PI controller	
5 ... 7		not in use	

5.4.6 Controller Status, Message Word

PI = 24h

Bit Number	Value	Meaning	Comment
0 ... 3	0, 1 ... 15	Optimization phase	0: no optimization
4, 5	0, 1, 2	Ramp active	0: no ramp 1: up 2: down
6, 7	0, 1, 2	Actuation active	0: no actuation 1: actuation manipulating factor active 2: dwell time active
8	0/1	Actual value control inactive/active	Controller status (channels 1 ... 8)
9	0/1	1: slowest channel of the group with regard to actual value control	
10, 11	0	not in use	
12 ... 14	0 ... 7	Mapping address	
15	0/1	Mapping completed	
0	0/1		
...	...		
7	0/1		Message word (channel 9)
8 ... 15	0	not in use	

5.4.7 Channel Error Mask

PI = 29h

Bit Number	Meaning
0	Broken sensor
1	Polarity reversal
2	Second upper limit value exceeded
3	First upper limit value exceeded
4	First lower limit value fallen short of
5	Second lower limit value fallen short of
6	Impermissible parameter
7	Heating current not off with deactivated actuating signal
8	Too little heating current with active actuating signal
9	Heating circuit error
10	Error starting adaptation
11	Adaptation error and abort
12	Too big heating current
13 ... 15	—

5.4.8 Group Error Mask

PI = 2Ah

Bit Number	Meaning
0	Broken sensor
1	Polarity reversal
2	Second upper limit value exceeded
3	First upper limit value exceeded
4	First lower limit value fallen short of
5	Second lower limit value fallen short of
6	Impermissible parameter
7	Heating current monitoring error
8	Heating circuit error
9	Adaptation error
10	Analog component error, 24V power supply is missing
11	Overload, heating current monitoring
12	Error in bus coupling
13	Reference junction error
14	EEPROM error, Parameter error
15	Group output error, 24V error

5.4.9 Alarm History

PI = 2Eh

The first three words contain the time stamp (no real-time clock!) for the time at which the error status changed. The contents of the last 12 words are identical to those of the error status (PI = 21h).

The entry "from channel to channel" makes reference to 16 bit words, i.e.

- Channel 1 ... 3 time stamp
- Channel 4 ... 11 channel error status 1 ... 8
- Channel 12 device error status
- Channel 13 ... 15 output error

Due to the fact that only 4 words are transmitted with backplane bus, the time stamp can be read where PI = 2Ch, whereas only the error status can be read with PI = 2Eh (same as PI = 21h).

Time stamp format where PI = 2Eh/2Ch or current time where PI = 90h:

Word / Channel	Character	Significance	Value Range	Comment
1	Low byte	Second Minute	0 ... 59	
	High byte		0 ... 59	
2	Low byte	Hour Day	0 ... 23	
	High byte		1 ... 31	
3	Low byte	Month Year	1 ... 12	
	High byte		0 ... 99	

5.5 Main Group 3: Device Specification

5.5.1 Table of Parameter Indices

PI	Parameter Designation	U/M	Format	Number	Setting Range	Comment
30h	Device ID	bit	8 bit	1	35h	Read only
31h	Device features	bit	8 bit	1	See chapter 5.5.2 on page 58	Read only
32h	Device control	bit	8 bit	1	See chapter 5.5.3 on page 58	
33h	Sensor type	bit	8 bit	8	See chapter 5.2.2 on page 53	
35h	Software version	bit	8 bit	1	(e.g. 57h = V5.7)	Read only
36h	Limit value configuration	bit	8 bit	8	See chapter 5.5.4 on page 58	
37h	Output configuration I/O	bit	8 bit	20	See chapter 5.5.5 on page 59	
	1 ... 16 continuous output 1 ... 4					
38h	Output configuration I/O	bit	8 bit	8	See chapter 5.5.5 on page 59	
3Ah	Power limitation	%	± 7 bit	1	0 = off, 12 ... 100%	compare chapter 2.2.5
3Dh	Block numbers	PI	8 bit	96	See chapter 4.3.5 on page 44	only via service interface
3Eh	Parameter set transfer	bit	8 bit	2 + 8	See chapter 4.3.6 on page 49	via backplane bus only
3Fh	Parameter set ID	bit	16 bit	3	See chapter 5.5.6 on page 59	

5.5.2 Device Features

PI = 31h

Bit Number	Value	Meaning	Comment
0	0	Standard version	Version
	1	OEM version of hardware and software	
1	0	EN 60870	Protocol of service interface
	1	Modbus	
2		not in use	
3	0	Thermocouple, Pt100	Sensor input
	1	DC 10V / 20mA	
4	0	with I/Os	Outputs
	1	without I/Os	
5	0	8 channels	Number of channels
	1	4 channels	
6, 7		not in use	

5.5.3 Device Control

PI = 32h

A code word including all 8 bits is written which starts the operation, and may stop it as well or set the parameter.

The 8 bits which are read include information regarding the operation in progress in the upper 4 bits, and the lower 4 bits contain parameters.

Write		Read		Meaning	
Bit number	Code / value	Bit number	Value		
0	0 / 1	0	0 / 1	Controlled variable quantity, °C / °F	
2 ... 3	0	2 ... 3	0	not in use	
1	0 / 1	1	0 / 1	Controller autonomous / outputs inactive when CPU in stop	
2 ... 3	0	2 ... 3	0	Not in use	
0 ... 7	0Fh	4 ... 7	Cannot be read back	Load factory default setting to momentary parameter set	
	1Eh			Save momentary parameter set to parameter set 1	
	1Fh			Load parameter set 1 to momentary parameter set	
	2Eh			Save momentary parameter set to parameter set 2	
	2Fh			Load parameter set 2 to momentary parameter set	
	3Eh			Copy current parameter set in transfer buffer	
	3Fh			Load transfer buffer in current parameter set	
	33h			reserved	
	66h			Send parameter set to CPU	
	99h			Send blocks to CPU	
0 ... 7	55h	4 ... 7	5h	Determination of heating current nominal values	
	—			0h	start / running finished
	AAh			Ah	Check sensor/heater assignment
	AAh			0h	start / running stop / finished

5.5.4 Limit Value Function and Heating Circuit Monitoring

PI = 36h

Bit Number	Value	Meaning
0	0 / 1	Alarm 1: setting relative/absolute to setpoint
1	0 / 1	Alarm 1: actuation suppression inactive/active
2	0 / 1	Alarm 2: setting relative/absolute to setpoint
3	0 / 1	Alarm 2: actuation suppression inactive/active
4	0 / 1	Heating circuit monitoring inactive/active
5	0 / 1	Limiter inactive / active
6	0 / 1	Alarm 1: Memory inactive / active
7	0 / 1	Alarm 2: Memory inactive / active

5.5.5 Output Configuration

PI = 37h and PI = 38h

- If all bits = 0, the output is inactive and has no function as an input.
- The continuous output can only be configured for manipulated variable read-out.
- If the I/Os 17 ... 24 are configured as heating outputs, no heating current monitoring is possible.

Standard Output Configuration of an Output (bit 0 = 0, bit 1 = 1)

Bit Number	Value	Discontinuous Output Manipulated Variable	Discontinuous Output Alarm	Continuous Output
0	0		Output	
1	1		Standard	
2 ... 4	0 ... 7		Channel number	
5	0 / 1	Heating / cooling	- / -	Heating / cooling
6	0 / 1	More / less	Operating current / closed-circuit current	Dead / live zero
7	0 / 1	0 = manipulated variable	1 = alarm	Manipulated variable

Special Output Configuration of an Output (bit 0 = 0, bit 1 = 0)

Bit Number	Value	Discontinuous Output	Continuous Output
0	0		Output
1	0		Special
2 ... 6	0 ... 31	Output function (see page 59)	Read-out zero / Reserved
7	0 / 1	Operating current / closed-circuit current	Dead / live zero

Standard Output Configuration of an Input (bit 0 = 1, bit 1 = 1)

Bit Number	Value	Discontinuous Output	Continuous Output
0	1	Input	Output
1	1		Standard
2 ... 4	0 ... 7	Channel number	Same as for configuration as output
5 ... 7	0 ... 7	Input function (see page 59)	

Special Output Configuration of an Input (bit 0 = 1, bit 1 = 0)

Bit Number	Value	Discontinuous Output	Continuous Output
0	1	Input	Output
1	0		Special
2, 3	0 ... 3	Group number	Same as for configuration as output
4 ... 7	0 ... 15	Input function (see page 59)	

Output Function

Value	Meaning	Comment
0	Output deactivated	
1 ... 8	Group error 1 ... 8	
9	Adaptation in progress, or adaptation error	
10 ... 13	Group error 0 ... 3	
14, 15	Reserved	
16	Independently controllable output	also for continuous outputs
17 ... 27	Reserved	
28	Data, 3 rd controller	External heating current monitoring with operating current only
29	Data, 2 nd controller	
30	Cycle	
31	Acknowledgement	

Input Function

Value	Meaning	Comment
0	Proxy setpoint active	Channel control or control per group
1	Actuation circuit	
2	Feed-forward control	
3	Temporary setpoint rise (Boost)	
4	Switching controller active	
5	Clear error	
6	Controller on	
7	Start self-tuning	
8 ... 15	Free inputs	Group number = 0
8 ... 11	—	Group number = 3
12	Logger stop	
13	Data external heating current monitoring	
14	Cycle external heating current monitoring	
15	Acknowledgement external heating current monitoring	

5.5.6 Parameter Set ID

PI = 3Fh

The parameter set ID consists of 3 words and can be read and written. It forms an integral part of each parameter set (bytes 19Ah...19Fh). The format is free, any value is permissible.

5.6 Main Group 6: Heating Current Monitoring

5.6.1 Table of Parameter Indices

PI	Parameter Designation	U/M	Format	Number	Setting Range	Comment
60h	Nominal heating current	0.1 A	± 15 bit	8	0 = off, 1 ... 10000	
61h	Heating current nominal value 2 nd controller	0.1 A	± 15 bit	8	0 = off, 1 ... 2500	
62h	Heating current nominal value 3 rd controller	0.1 A	± 15 bit	8	0 = off, 1 ... 2500	
64h	Summation current transformation ratio	0.1 A	± 15 bit	1	0 ... 10000	
67h	Heating current sampling cycle	0,1 s	± 15 bit	1	0 = Auto, 1 ... 30000	
69h	Heating voltage transformer secondary voltage	0.1 V	± 15 bit	1	0, 100 ... 500	
6Ch	Heating current - actual value	0.1 A	± 15 bit	8		read only
6Dh	Heating current - actual value 2 nd controller	0.1 A	± 15 bit	8		read only
6Eh	Heating current - actual value 3 rd controller	0.1 A	± 15 bit	8		read only
6Fh	Heating voltage - actual value	0.1 V	± 15 bit	1		read only

5.7 Main Group 9: Data Logger

Refer to chapter 2.9.2 on page 26 for a detailed description of the functions of the quantities.

5.7.1 Table of Parameter Indices

PI	Parameter Designation	U/M	Format	Number	Setting Range	Comment
90h	Current time (no real-time clock)	—	16 bit	3	See chapter 5.4.9 on page 57	
92h	Logger sampling cycle	0.1 s	± 15 bit	1	0.1 ... 600.0 s	
93h	Logger control	bit	8 bit	1	0/1 = Logger Run / Stop	
94h	Read-out starting point sampled actual values	—	± 15 bit	1	1 ... 3600	
95h	Read-out starting point sampled manipulated variables	—	± 15 bit	1	1 ... 3600	
96h	Sampled actual values	0.1 °	± 15 bit	(1 ... 15) x 8	MbA ... MbE	Read only ¹⁾
97h	Sampled manipulated variables	%	± 15 bit	(1 ... 15) x 8	-100 ... 100	Read only ¹⁾
98h	Number of samples	—	± 15 bit	1	0 ... 3600	Read only
99h	Time of last sample	—	16 bit	3	same as PI = 90h	

¹⁾ Refer to chapter 2.9.2 on page 26 for a detailed description

5.8 Main Group B: Display Values

5.8.1 Table of Parameter Indices

PI	Parameter Designation	U/M	Format	Number	Setting Range	Comment
B0h	Momentary setpoint	0.1 °	± 15 bit	8		Read only
B1h	Momentary actual value	0.1 °	± 15 bit	8		Read only
B2h	Momentary system deviation	0.1 °	± 15 bit	8		Read only
B3h	Momentary reference junction temperature	0.1 °	± 15 bit	1		Read only
B7h	Momentary manipulating factor	%	± 15 bit	8		Read only
B8h	Momentary setpoint	1 °	± 15 bit	8		Read only
B9h	Momentary actual value	1 °	± 15 bit	8		Read only
BAh	Momentary system deviation	1 °	± 15 bit	8		Read only

5.9 Main Group E: Control Functions

PI	Parameter Designation	U/M	Format	Number	Setting Range	Comment
E1	State of continuous outputs	0.1%	16 bit	4	0 ... 1000	¹⁾

¹⁾ When the output is configured as an „independently controllable output“, the state can be written as well.

6 Index

Numerics

- 2-step controller 19, 20
- 2-wire connection 10
- 3-step controller 7, 19, 20
- 50 mV 6, 12

A

- Actual value 9
 - external 9, 56
- Actual value control 9, 17
- Actual value determination 9
- Actual value difference 13, 17
- Actuation 8
- Actuation circuit 9, 16, 17
- Actuation suppression 22
- Actuation test 19
- Actuator 7, 13
 - adaptive 9
- Alarm 59
- Alarm history 28
- Alarm memory 22
- Alarm suppression 22
- Alarms generated by the device 37
- Analog error 21
- Assignment of sensor and heater 27
- Assignment to groups 15
- Automatic operating mode 15

B

- Baudrate 31
- Binary input 13, 15, 16
- Binary outputs 25
- Broken sensor 21, 24
- Bumpless 15

C

- Channel control 59
- Channels not required 13
- Channel-specific alarms 25
- Character delay time 31
- Checksum 34
- Clear errors 25
- Communication 31
- Contactors 8, 56
- Continuous output 59
- Continuous-action controller 7, 19, 20
- Control commands 29, 51, 52
- Control Functions 52, 60
- Control of continuous outputs 26
- Control parameters 29, 51
- Control per group 15, 59
- Control per individual channel 15
- Control string 32
- Controller amplification 18
- Controller channels 15
- Controller output 7
- Cooling 7
- Cooling operating point 20
- Cooling output 7
- Correct wiring 27
- Current inputs 23

D

- Data logger 26, 29, 52
- Dead zone 6
- Default setting 6, 28
- Derivative-action time, integral-action time 18

- Device specification 29, 51, 52
- Device Specifications 52
- Differential controller 13
- DIP switch 6
- Discontinuous output 59
- Display value 10, 12, 51
- Display values 52
- Dwell time 16

E

- EEPROM 29
- EEPROM error 21
- EN 60870 31
- Error LED 21, 25, 55
- Error messages 37
- Error status 28, 57
- Error status word 37, 55
- Evaporation 8
- Events data 37, 55

F

- Feed-forward control 16
- Fühlertyp 53
- Function field 33
- Function selection 54

G

- Group 17
- Group alarms 25
- Group error 59
- Group of control channels 17

H

- Half-duplex operating mode 31
- Hardware reset 35
- Heating 7
- Heating circuit error 21
- Heating circuit monitoring 22
- Heating current monitoring 23, 29, 51, 52
- Heating current not off 21
- Heating currents of the 2nd and 3rd controller 36
- Heating output 7
- Heating voltage 23
- Heating voltage fluctuation 23
- Heating voltage overload 21
- Hot-runner control 16, 17

I

- Impermissible parameter 21
- Input filter 13
- Interference 9

L

- Lasting deviation 13
- Less 7
- Limit value monitoring 13, 22
- Limit values 9
- Live zero 7
- Load fluctuation 16
- Long string 32

M

- Manipulated variable 13, 59
- Manual operating mode 15
- Manual optimization 19, 20
- Mapping error 21
- Master actual value 9
- Master controller 13

- Measured value 10, 12
- Measured value correction 9
- Measurement and evaluation data 36
- Measuring cycle 23
- Messanfang 53
- Messende 53
- Momentary setpoint 9
- Monitoring functions 21
 - More 7
 - mV 6, 12

N

- Non-volatile memory 28

O

- Off state 15
- Optimized controller dynamics 18
- Oscillation amplitude 19, 20
- Oscillation test 18, 19
- Output error 37
- Output monitoring 25
- Overheating 18
- Overload, heating current 21
- Overshooting 18

P

- Parallel connected heaters 23
- Parameter error 21, 39
- Parameter sets 28
- Parameters index 34, 38, 39
- Parität 31
- PDPI control algorithm 13
- Periodic interference 9
- Periodic oscillation 10
- Polarity reversal 21
- Proportional zone 6

Q

- Quantities other than temperature 12
- Query
 - “Device OK?” 33
- Query waiting time 31

R

- Ramp gradient 17
- Range lower limit 6
- Range upper limit 6
- Reference junction error 21
- Request cycle data 33
- Request data from controller 33
- Request events data 33
- Request heating currents 33
- Reset device 33
- Resistance thermometer 10
- Response delay time 31
- RS-232 31

S

- Scaling 12
- Second limit value 22
- Self-optimization 9, 18
- Self-tuning error 21
- Self-tuning sequence 17
- Self-tuning start-up error 21
- Sensor 13
- Sensor type 6
- Setpoint 13, 16
- Setpoint processing 9
- Setpoint rise 17

Setting ranges	53
Settling time without overshooting	13
Short string	32
Short-circuiting of the Pt100	24
Slave controller	9, 13
Step-action control	17
Step-action controller.	7, 19, 20
Summation current transformer	23
Sustained oscillation.	20
Switching controller	13
Switching hysteresis.	6
Synchronous heat-up.	17
System deviation	13

T

Targeted setpoint.	9
Temperature	10
Temperature difference	17
Temperature drop	10
Temperature measurement inputs	6
Temperature monitoring.	13
Temperature parameters	29, 51, 53
Temperature sensor	10
Temporary setpoint rise	16
Test time	27
Thermocouple polarity reversal.	24
Thermoelectromotive forces.	17
Three-step control	17
Time constant	13
Time stamp	57
Too big heating current	21
Too little heating current.	21
Transmit data to controller	33
Two-step control	17

U

Units of measure	53
unused.	6

V

Voltage transformer	23
-------------------------------	----

7 Parameter Index

Numerics

2-step controller7

A

Absolute limit values22
Actual value
 external 9, 51, 54
Actual value control 15, 17, 56
Actual value control inactive/active ...56
Actual value correction 9, 10, 12, 29, 51, 53
Actual value factor .9, 10, 12, 29, 51, 53
Actuating cycle13
Actuating signal7
Actuation active56
Actuation circuit 16, 54, 59
Actuation cycle time 13, 16, 18, 29
Actuation manipulating factor .16, 29, 51, 54
Actuation setpoint9, 16, 29, 51, 53
Actuation suppression 22, 58
Actuator 13, 56
Actuator manipulating factor .13, 29, 51, 54
Adaptation error and abort 55, 57
Adaptive measured value correction .56
Alarm history 52, 54
Alarm history entries28
Alarm history read-out starting point .28, 52,54
Alarm history, time stamp 52, 54
Alarm memory22
Analog component error 55, 57

B

Block numbers 52, 58
Boost 9, 16, 29, 51, 53, 54, 59
Boost duration 16, 29, 51, 53
Broken sensor 24, 27, 55, 57

C

Channel error mask 25, 29, 51, 54
Channel error status . 18, 22, 24, 25, 27, 54
Channel error status word21
Channel not in use 13, 56
Clear error 22, 54, 59
Controlled variable quantity58
Controller class 6, 13, 56
Controller configuration 8, 9, 15, 16, 17, 29, 51, 54
 extended8, 9, 29, 51, 54, 56
Controller function 6, 15, 16, 18, 19, 29, 51,54
Controller on .6, 13, 15, 18, 19, 20, 54, 59
Controller status ...9, 16, 17, 18, 27, 56
Controller status, message word . 51, 54
Controller type 6, 13, 16, 17, 18, 19, 20, 22, 27, 56
Current time 52, 60
Cycle time 8, 19, 51, 54

D

D-component56

Dead zone13, 19, 20, 29, 51, 54
Delay 19, 20, 22, 23, 27
Device characteristic52
Device control .6, 23, 27, 28, 29, 52, 58
Device error status 21, 25, 27, 54
Device features58
Device ID 52, 58
Differential controller13, 56
Dwell time16, 29
Dwell time during actuation51, 53

E

EEPROM error 55, 57
EN 6087058
Error starting adaptation55, 57
Error status51, 52
Events data 18, 21, 22

F

Factory default setting58
Feed-forward control 16, 54, 59
First lower limit value 29, 51, 53
First upper limit value 29, 51, 53
Fixed setpoint controller 6, 13, 56
Free outputs26

G

Group 15, 17, 56
Group alarms15, 25
Group error mask 25, 29, 52, 54

H

Heating circuit error 22, 55, 57
Heating circuit monitoring22, 58
Heating current - actual value ...51, 60
Heating current nominal value 23, 24, 29, 51,58, 60
Heating current nominal value 2nd controller 29, 52, 60
Heating current nominal value 3rd controller 29, 52, 60
Heating current not off 23, 55, 57
Heating current sampling cycle .23, 24, 29,52, 60
Heating voltage - actual value ...52, 60
Heating voltage transformer secondary voltage52, 60
Hot-runner 8, 16, 17, 56
Hysteresis22

I

Impermissible parameter 55, 57
Influencing quantity manipulating factor .16, 29, 51, 54
Input filter13

L

Limit transducer13, 56
Limit value configuration .22, 29, 51, 58
Limit value exceeded55, 57
Limit value fallen short of55, 57
Limit value function22
Limiter22, 58
Logger control52, 60

Logger sampling cycle .. 26, 29, 52, 60
Lower limit value22

M

Manual instead of off15, 56
Manual manipulating factor ...15, 51, 54
Mapping address27, 56
Mapping completed27, 56
Mapping error27, 55
Master actual value17, 52, 54
Master controller13, 56
Maximum manipulating factor 16, 19, 20, 29,51, 54
Maximum setpoint 9, 29, 51, 53
Measuring13, 56
Memory58
Message word56
Minimum manipulating factor .19, 20, 29, 51,54
Minimum setpoint 9, 29, 51, 53
Modbus58
Momentary actual value51, 60
Momentary manipulating factor ...51, 60
Momentary setpoint51, 60
Momentary state of the continuous outputs26
Momentary system deviation51, 60
Motor actuation time 19, 29, 51, 54

N

Number of entries, alarm history .28, 52, 54
Number of samples26, 52, 60

O

Optimization phase56
Oscillation hold-off10, 29, 51
Output configuration 6, 7, 15, 25, 29, 52,58, 59
Output error 25, 54, 55, 57
Overload57
Overload, heating current55
Overload, heating voltage55

P

Parameter error55, 57
Parameter set58
Parameter set transfer52
Partner channel9, 13, 56
PDPI 6, 16, 20, 22
PDPI controller 13, 17, 18, 56
PI controller56
Polarity reversal 24, 27, 55, 57
Power limitation 8, 29, 52, 58
Proportional actuator13, 56
Proportional zone 18, 19, 20, 22
Proportional zone cooling ...29, 51, 54
Proportional zone heating ...29, 51, 54
Proxy setpoint9, 13, 29, 51, 53, 59
Proxy setpoint active54

R

Ramp active56
Read-out starting point sampled actual values52, 60

Read-out starting point sampled manipulated variables	52, 60
Read-out starting point sampled values	26
Reference junction error	55, 57
Reference junction temperature	52
Reference junction temperature, momentary	60
Relative limit values	22
Relative/absolute	58

S

Sampled actual values	52, 60
Sampled manipulated variables	60
Sampled values	26
Samples manipulated variables	52
Save alarm 2 active	22
Second limit values	22
Second lower limit value	29, 51, 53
Second upper limit value	29, 51, 53
Secondary heating voltage	23, 29
Self-tuning	18
Self-tuning error	18
Self-tuning on	18
Sensor error manipulating factor	24, 29, 51, 54
Sensor type	6, 10, 12, 29, 51, 58
Sensor/heater assignment	58
Setpoint	9, 22, 29, 51, 53
Setpoint ramp, down	29, 51, 53
Setpoint ramp, up	29, 51, 53
Setpoint rise	9, 16, 29, 51, 53
Slave controller	13, 56
Software version	52, 58
Start error	18
Start self-tuning	54, 59
State of continuous outputs	52, 60
Summation current transformation ratio	23, 29, 52, 60
Switching controller	13, 56
Switching controller active	54, 59
Switching hysteresis	13, 29, 51, 54
System delay	9, 18, 29, 51, 54

T

Temporary setpoint rise	16, 54, 59
Time of last sample	52, 60
Time of the last sample	26
Time stamp	28, 54
Too big heating current	23, 24, 55, 57
Too little heating current	23, 55, 57
Tu	18, 19, 20, 22, 51
Ty	19

U

Unit of measure	10, 12
Upper limit value	22

W

Water cooling	8, 56
---------------	-------

X

Xpl	19, 20, 51
Xpll	19, 20, 51
Xpl	18, 22

8 Repair and Replacement Parts Service and Rental Instrument Service

When you need service, please contact:

GMC-I Service GmbH

Service Center
Thomas-Mann-Straße 20
90471 Nürnberg • Germany
Phone +49 911 817718-0
Fax +49 911 817718-253
E-Mail service@gossenmetrawatt.com

VIPA

Gesellschaft für Visualisierung
und Prozessautomatisierung mbH
Ohmstrasse 4
91074 Herzogenaurach • Germany
Phone +49 9132 744-0
Fax +49 9132 744-174
E-Mail info@vipa.de
www.vipa.de

This address is only valid in Germany.
Please contact our representatives or subsidiaries for service in other countries.

9 Product Support

When you need support, please contact:

GMC-I Messtechnik GmbH

Product Support Hotline
Phone +49 911 8602-500
Fax +49 911 8602-340
E-Mail support@gossenmetrawatt.com

VIPA

Gesellschaft für Visualisierung
und Prozessautomatisierung mbH
Ohmstrasse 4
91074 Herzogenaurach • Germany
Phone +49 9132 744-110/112/113
Fax +49 9132 744-174
E-Mail info@vipa.de
www.vipa.de

VIPA, System 300V are registered trademarks of VIPA Gesellschaft für Visualisierung und Prozessautomatisierung mbH. SIMATIC, STEP S7-300 are registered trademarks of Siemens AG.

Edited in Germany • Subject to change without notice • A PDF version is available on the Internet

VIPA, Gesellschaft für Visualisierung
und Prozessautomatisierung mbH
Ohmstrasse 4
91074 Herzogenaurach • Germany

Phone +49 9132 744-0
Fax +49 9132 744-174
E-Mail info@vipa.de
www.vipa.de



GOSSEN METRAWATT

GMC-I Messtechnik GmbH
Südwestpark 15
90449 Nürnberg • Germany

Phone +49 911 8602-0
Fax +49 911 8602-669
E-Mail info@gossenmetrawatt.com
www.gossenmetrawatt.com