

VIPA System 300S

SM-AIO | | Manual

HB140 | SM-AIO | | GB | Rev. 16-39

Analog signal modules - SM 33x(S)

VIPA GmbH
Ohmstr. 4
91074 Herzogenaurach
Telephone: 09132-744-0
Fax: 09132-744-1864
Email: info@vipa.com
Internet: www.vipa.com

Table of contents

1	Basics	5
1.1	Copyright © VIPA GmbH	5
1.2	Über dieses Handbuch.....	6
1.3	Safety information.....	7
2	Assembly and installation guidelines	9
2.1	Safety information for users.....	9
2.2	Overview.....	9
2.3	Installation dimensions.....	10
2.4	Assembly SPEED-Bus.....	12
2.5	Assembly standard bus.....	15
2.6	Cabling.....	17
2.7	Installation guidelines.....	20
2.8	General data I/O modules.....	23
2.8.1	General data.....	23
3	Analog Input Modules	26
3.1	Principles.....	26
3.2	Parameterization - Basics.....	27
3.2.1	Parameterization by hardware configuration.....	27
3.2.2	Parameterization during runtime.....	27
3.3	331-1KF01 - AI 8x13Bit	30
3.3.1	331-1KF01 - AI 8x13Bit - Parameterization.....	34
3.3.2	331-1KF01 - Technical data.....	40
3.4	331-7Kx01 - AI 8(2)x12Bit	45
3.4.1	Connection of sensors	48
3.4.2	331-7Kx01 - AI 8(2)x12Bit - Parameterization.....	53
3.4.3	331-7Kx01 - AI 8(2)x12Bit - Diagnostics.....	61
3.4.4	331-7KB01 - Technical data.....	66
3.4.5	331-7KF01 - Technical data.....	73
4	Analog Output Modules	80
4.1	General.....	80
4.2	Connecting loads and actuators.....	80
4.3	Analog value representation.....	82
4.4	Parameterization - Basics.....	82
4.4.1	Parameterization by hardware configuration.....	82
4.4.2	Parameterization during run time by means of SFCs... ..	83
4.5	Diagnostics	86
4.6	332-5HB01 - AO 2/4x12Bit U/I 2-channel.....	90
4.6.1	Technical data.....	93
4.7	332-5HD01 - AO 2/4x12Bit U/I 4-channel.....	96
4.7.1	Technical data.....	99
4.8	332-5HD50 - AO 4x12Bit I for manual operation.....	102
4.8.1	Manual operation.....	105
4.8.2	Technical data.....	106
4.9	332-5HD60 - AO 4x12Bit U for manual operation.....	109

4.9.1	Manual operation.....	111
4.9.2	Technical data.....	112
5	Analog I/O Modules.....	115
5.1	General.....	115
5.2	Analog value representation.....	115
5.3	Parameterization.....	118
5.3.1	Parameterization by hardware configuration.....	118
5.3.2	Parameterization during run time by means of SFCs..	119
5.4	334-0KE00 - AI 4/AO 2x12Bit	120
5.4.1	Technical data.....	121
6	Analog I/O Modules FAST - SPEED-Bus.....	128
6.1	General.....	128
6.2	Analog value representation.....	129
6.3	Operating modes.....	130
6.4	Addressing at SPEED-Bus.....	131
6.5	Project engineering.....	132
6.5.1	Fast introduction.....	132
6.5.2	Preconditions.....	132
6.5.3	Steps of project engineering.....	133
6.6	Parameterization.....	135
6.6.1	Structure of the parameter bytes.....	136
6.7	SFC 193 - Oscilloscope-/FIFO function	140
6.8	Example for the Oscilloscope function.....	144
6.8.1	Example for the FIFO function.....	146
6.9	Diagnostics.....	150
6.9.1	Process interrupts.....	152
6.10	331-7AF70 - AI 8x16Bit I	153
6.10.1	Technical data.....	156
6.11	331-7BF70 - AI 8x16Bit U.....	159
6.11.1	Technical data.....	161

1 Basics

1.1 Copyright © VIPA GmbH

All Rights Reserved

This document contains proprietary information of VIPA and is not to be disclosed or used except in accordance with applicable agreements.

This material is protected by the copyright laws. It may not be reproduced, distributed, or altered in any fashion by any entity (either internal or external to VIPA), except in accordance with applicable agreements, contracts or licensing, without the express written consent of VIPA and the business management owner of the material.

For permission to reproduce or distribute, please contact: VIPA, Gesellschaft für Visualisierung und Prozessautomatisierung mbH Ohmstraße 4, D-91074 Herzogenaurach, Germany

Tel.: +49 9132 744 -0

Fax.: +49 9132 744-1864

E-Mail: info@vipa.de

<http://www.vipa.com>



Every effort has been made to ensure that the information contained in this document was complete and accurate at the time of publishing. Nevertheless, the authors retain the right to modify the information.

This customer document describes all the hardware units and functions known at the present time. Descriptions may be included for units which are not present at the customer site. The exact scope of delivery is described in the respective purchase contract.

CE Conformity Declaration

Hereby, VIPA GmbH declares that the products and systems are in compliance with the essential requirements and other relevant provisions. Conformity is indicated by the CE marking affixed to the product.

Conformity Information

For more information regarding CE marking and Declaration of Conformity (DoC), please contact your local VIPA customer service organization.

Trademarks

VIPA, SLIO, System 100V, System 200V, System 300V, System 300S, System 400V, System 500S and Commander Compact are registered trademarks of VIPA Gesellschaft für Visualisierung und Prozessautomatisierung mbH.

SPEED7 is a registered trademark of profichip GmbH.

SIMATIC, STEP, SINEC, TIA Portal, S7-300 and S7-400 are registered trademarks of Siemens AG.

Microsoft and Windows are registered trademarks of Microsoft Inc., USA.

Portable Document Format (PDF) and Postscript are registered trademarks of Adobe Systems, Inc.

All other trademarks, logos and service or product marks specified herein are owned by their respective companies.

Information product support

Contact your local VIPA Customer Service Organization representative if you wish to report errors or questions regarding the contents of this document. If you are unable to locate a customer service centre, contact VIPA as follows:

VIPA GmbH, Ohmstraße 4, 91074 Herzogenaurach, Germany

Telefax: +49 9132 744-1204

E-Mail: documentation@vipa.de

Technical support

Contact your local VIPA Customer Service Organization representative if you encounter problems with the product or have questions regarding the product. If you are unable to locate a customer service centre, contact VIPA as follows:

VIPA GmbH, Ohmstraße 4, 91074 Herzogenaurach, Germany

Tel.: +49 9132 744-1150 (Hotline)

E-Mail: support@vipa.de

1.2 Über dieses Handbuch

Target audience

The manual is targeted at users who have a background in automation technology.

Structure of the manual

The manual consists of chapters. Every chapter provides a self-contained description of a specific topic.

Guide to the document

The following guides are available in the manual:

- An overall table of contents at the beginning of the manual
- References with page numbers

Availability

The manual is available in:

- printed form, on paper
- in electronic form as PDF-file (Adobe Acrobat Reader)

Icons Headings

Important passages in the text are highlighted by following icons and headings:

**DANGER!**

Immediate or likely danger. Personal injury is possible.

**CAUTION!**

Damages to property is likely if these warnings are not heeded.



Supplementary information and useful tips.

1.3 Safety information

Applications conforming with specifications

The system is constructed and produced for:

- communication and process control
- general control and automation tasks
- industrial applications
- operation within the environmental conditions specified in the technical data
- installation into a cubicle

**DANGER!**

This device is not certified for applications in
– in explosive environments (EX-zone)

Documentation

The manual must be available to all personnel in the

- project design department
- installation department
- commissioning
- operation

**CAUTION!**

The following conditions must be met before using or commissioning the components described in this manual:

- Hardware modifications to the process control system should only be carried out when the system has been disconnected from power!
- Installation and hardware modifications only by properly trained personnel.
- The national rules and regulations of the respective country must be satisfied (installation, safety, EMC ...)

Disposal

National rules and regulations apply to the disposal of the unit!

2 Assembly and installation guidelines

2.1 Safety information for users

Handling of electrostatic sensitive modules

VIPA modules make use of highly integrated components in MOS-Technology. These components are extremely sensitive to over-voltages that can occur during electrostatic discharges. The following symbol is attached to modules that can be destroyed by electrostatic discharges.



The Symbol is located on the module, the module rack or on packing material and it indicates the presence of electrostatic sensitive equipment. It is possible that electrostatic sensitive equipment is destroyed by energies and voltages that are far less than the human threshold of perception. These voltages can occur where persons do not discharge themselves before handling electrostatic sensitive modules and they can damage components thereby, causing the module to become inoperable or unusable. Modules that have been damaged by electrostatic discharges can fail after a temperature change, mechanical shock or changes in the electrical load. Only the consequent implementation of protection devices and meticulous attention to the applicable rules and regulations for handling the respective equipment can prevent failures of electrostatic sensitive modules.

Shipping of modules

Modules must be shipped in the original packing material.

Measurements and alterations on electrostatic sensitive modules

When you are conducting measurements on electrostatic sensitive modules you should take the following precautions:

- Floating instruments must be discharged before use.
- Instruments must be grounded.

Modifying electrostatic sensitive modules you should only use soldering irons with grounded tips.



CAUTION!

Personnel and instruments should be grounded when working on electrostatic sensitive modules.

2.2 Overview

General

While the standard peripheral modules are plugged-in at the right side of the CPU, the SPEED-Bus peripheral modules are connected via a SPEED-Bus bus connector at the left side of the CPU. VIPA delivers profile rails with integrated SPEED-Bus for 2, 6 or 10 SPEED-Bus peripheral modules with different lengths.

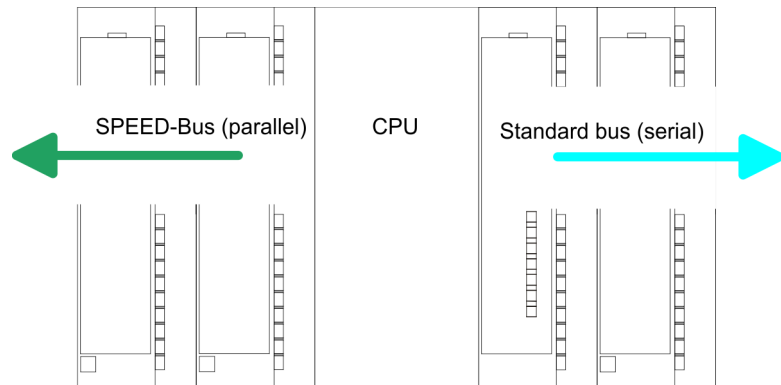

Serial Standard bus

The single modules are directly installed on a profile rail and connected via the backplane bus coupler. Before installing the modules you have to clip the backplane bus coupler to the module from the backside. The backplane bus couplers are included in the delivery of the peripheral modules.

Parallel SPEED-Bus

With SPEED-Bus the bus connection happens via a SPEED-Bus rail integrated in the profile rail at the left side of the CPU. Due to the parallel SPEED-Bus not all slots must be occupied in sequence.

SLOT 1 for additional power supply

At slot (SLOT 1 DCDC) you may plug either a SPEED-Bus module or an additional power supply.

Assembly possibilities

You may assemble the System 300 horizontally, vertically or lying.

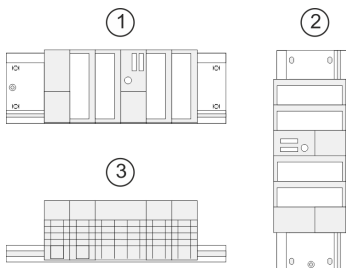

Please regard the allowed environment temperatures:

- horizontal assembly: from 0 to 60°C
- vertical assembly: from 0 to 40°C
- lying assembly: from 0 to 40°C

2.3 Installation dimensions

Dimensions Basic enclosure

1tier width (WxHxD) in mm: 40 x 125 x 120

Dimensions

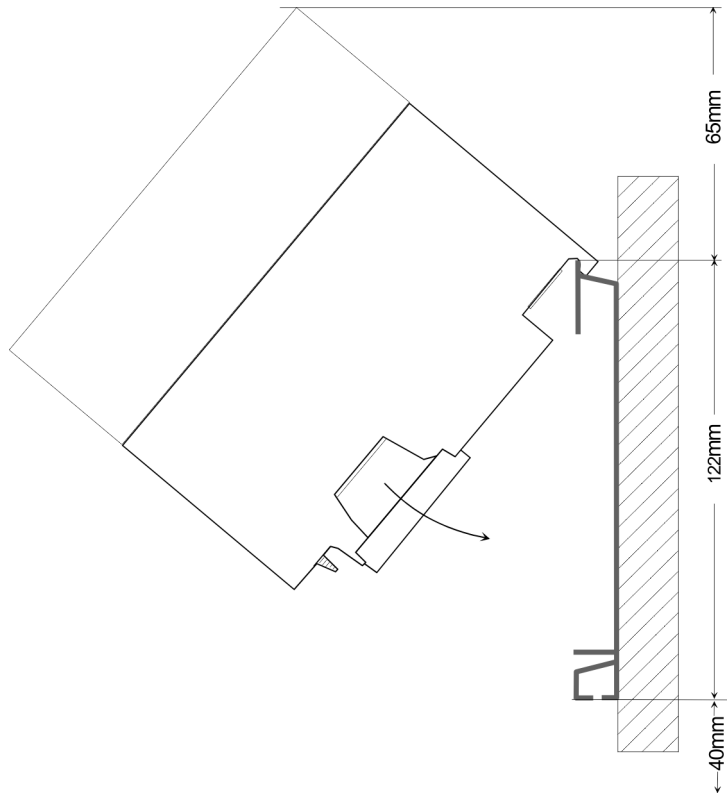

Installation dimensions

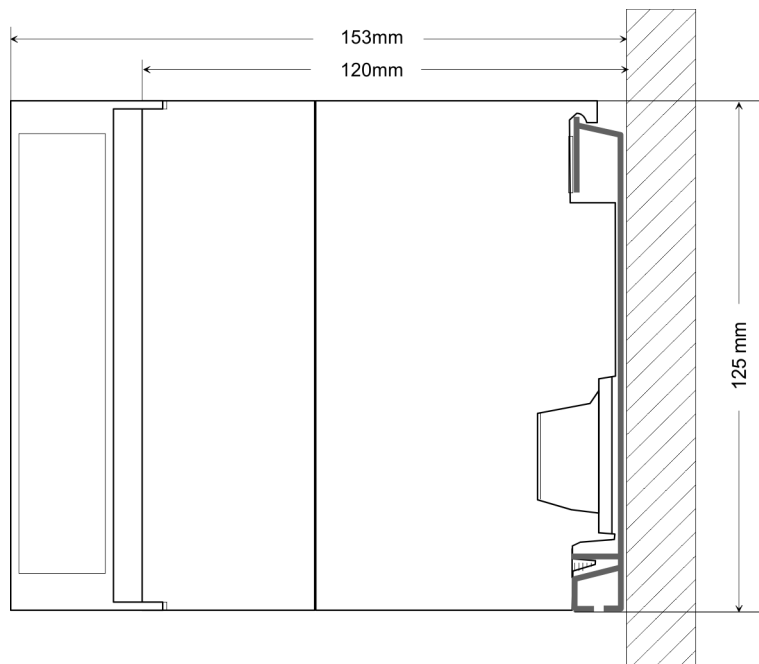

2.4 Assembly SPEED-Bus

Pre-manufactured SPEED-Bus profile rail

For the deployment of SPEED-Bus modules, a pre-manufactured SPEED-Bus rail is required. This is available mounted on a profile rail with 2, 6 or 10 extension slots.



Dimensions

Order number	Number of modules SPEED-Bus/Standard bus	A	B	C	D	E
391-1AF10	2/6	530	100	268	510	10
391-1AF30	6/2	530	100	105	510	10
391-1AF50	10/0	530	20	20	510	10
391-1AJ10	2/15	830	22	645	800	15
391-1AJ30	6/11	830	22	480	800	15
391-1AJ50	10/7	830	22	320	800	15

Measures in mm

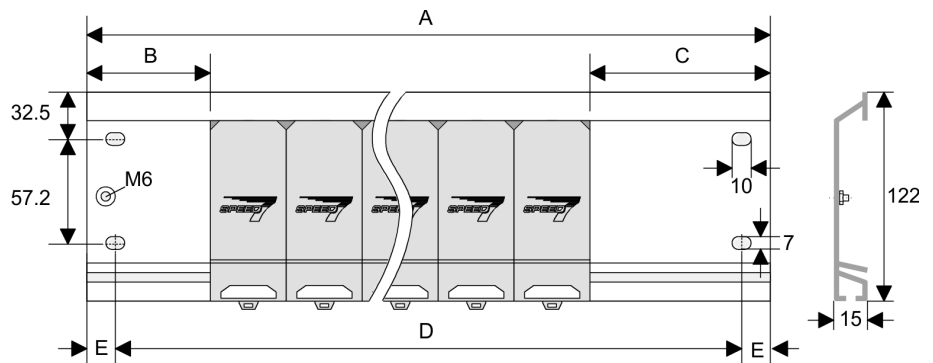

Installation of the profile rail

1. ▶ Bolt the profile rail with the background (screw size: M6), so that you still have minimum 65mm space above and 40mm below the profile rail. Please look for a low-impedance connection between profile rail and background.

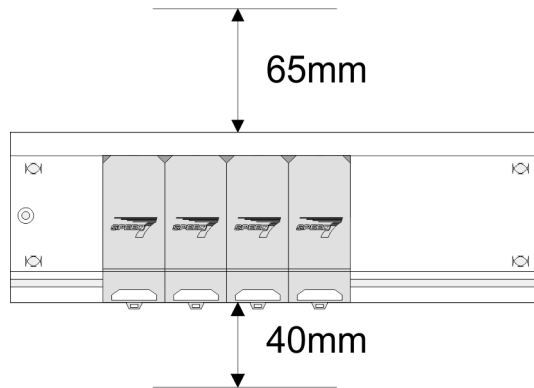

2. ▶ Connect the profile rail with the protected earth conductor. The minimum cross-section of the cable to the protected earth conductor has to be 10mm².

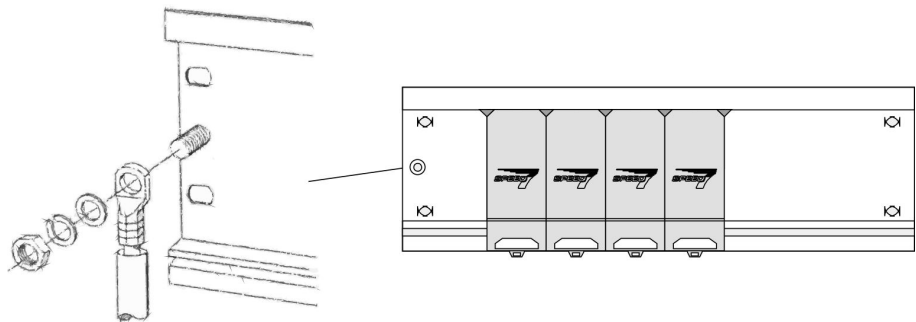

Installation SPEED-Bus module

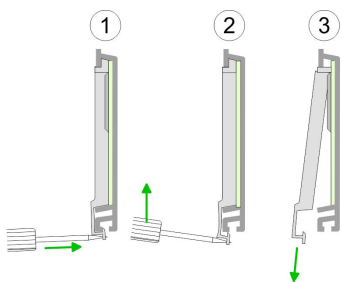

1. ▶ Dismantle the according protection flaps of the SPEED-Bus slot with a screw driver (open and pull down).

For the SPEED-Bus is a parallel bus, not every SPEED-Bus slot must be used in series. Leave the protection flap installed at an unused SPEED-Bus slot.

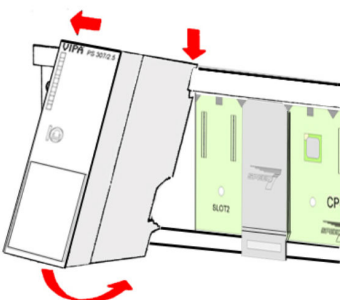

2. ▶ At deployment of a DC 24V power supply, install it at the shown position at the profile rail at the left side of the SPEED-Bus and push it to the left to the isolation bolt of the profile rail.
3. ▶ Fix the power supply by screwing.

Assembly SPEED-Bus

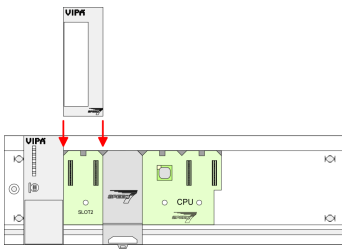

4. ▶ To connect the SPEED-Bus modules, plug it between the triangular positioning helps to a slot marked with "SLOT ..." and pull it down.
5. ▶ Only the "SLOT1 DCDC" allows you to plug-in either a SPEED-Bus module or an additional power supply.
6. ▶ Fix the CPU by screwing.

Installation CPU without Standard-Bus-Modules

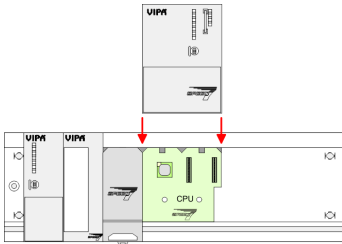

1. ▶ To deploy the SPEED7-CPU exclusively at the SPEED-Bus, plug it between the triangular positioning helps to the slot marked with "CPU SPEED7" and pull it down.

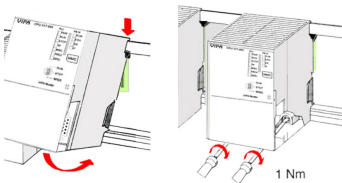

2. ▶ Fix the CPU by screwing.

Installation CPU with Standard-Bus-Modules

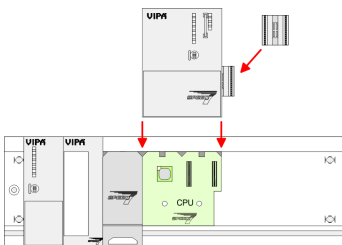

1. ▶ If also standard modules shall be plugged, take a bus coupler and click it at the CPU from behind like shown in the picture. Plug the CPU between the triangular positioning helps to the slot marked with "CPU SPEED7" and pull it down.

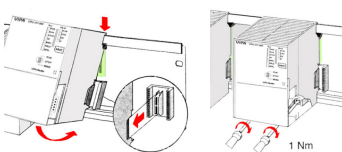

2. ▶ Plug the CPU between the triangular positioning helps to the plug-in location marked with "CPU SPEED7" and pull it down. Fix the CPU by screwing.

Installation Standard-Bus-Modules

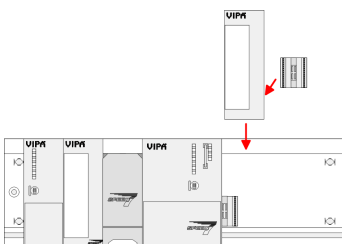

- ▶ Repeat this procedure with the peripheral modules, by clicking a backplane bus coupler, stick the module right from the modules you've already fixed, click it downwards and connect it with the backplane bus coupler of the last module and bolt it.



CAUTION!

- The power supplies must be released before installation and repair tasks, i.e. before handling with the power supply or with the cabling you must disconnect current/voltage (pull plug, at fixed connection switch off the concerning fuse)!
- Installation and modifications only by properly trained personnel!

2.5 Assembly standard bus

General

The single modules are directly installed on a profile rail and connected via the backplane bus connector. Before installing the modules you have to clip the backplane bus connector to the module from the backside. The backplane bus connector is delivered together with the peripheral modules.

Profile rail

Order number	A	B	C
390-1AB60	160	140	10
390-1AE80	482	466	8.3
390-1AF30	530	500	15
390-1AJ30	830	800	15
390-9BC00*	2000	Drillings only left	15

*) Unit pack: 10 pieces

Measures in mm

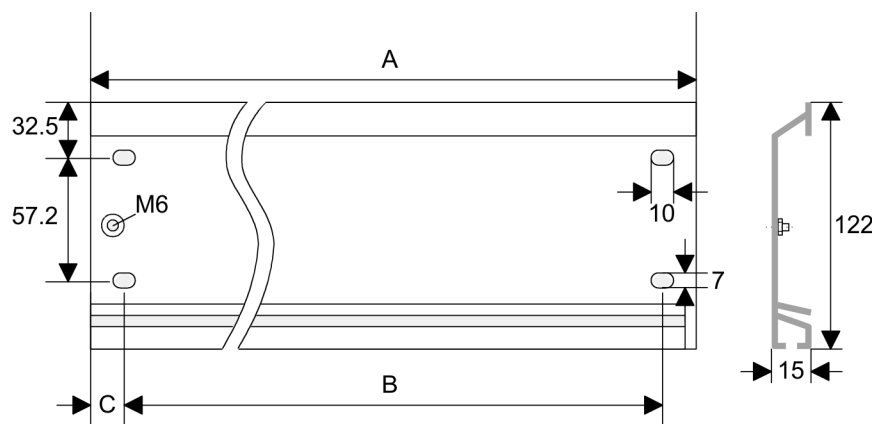

Bus connector

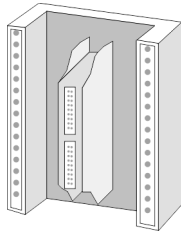

For the communication between the modules the System 300S uses a backplane bus connector. Backplane bus connectors are included in the delivering of the peripheral modules and are clipped at the module from the backside before installing it to the profile rail.

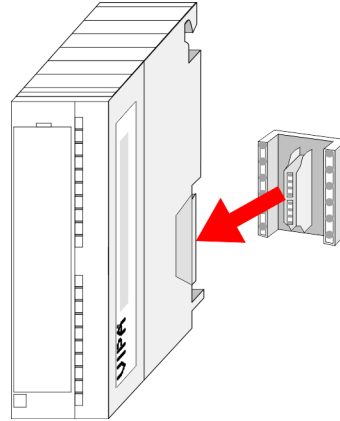

Assembly possibilities

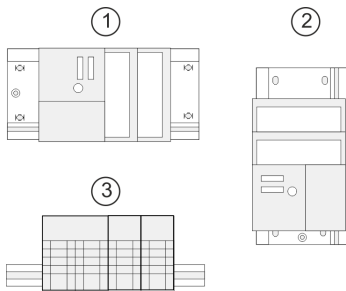

Please regard the allowed environment temperatures:

- horizontal assembly: from 0 to 60°C
- vertical assembly: from 0 to 50°C
- lying assembly: from 0 to 55°C

Approach

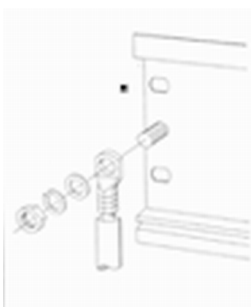

If you do not deploy SPEED-Bus modules, the assembly happens with the following approach:

1. ➤ Bolt the profile rail with the background (screw size: M6), so that you still have minimum 65mm space above and 40mm below the profile rail.
2. ➤ If the background is a grounded metal or device plate, please look for a low-impedance connection between profile rail and background.
3. ➤ Connect the profile rail with the protected earth conductor. For this purpose there is a bolt with M6-thread.
4. ➤ The minimum cross-section of the cable to the protected earth conductor has to be 10mm².
5. ➤ Stick the power supply to the profile rail and pull it to the left side to the grounding bolt of the profile rail.
6. ➤ Fix the power supply by screwing.
7. ➤ Take a backplane bus connector and click it at the CPU from the backside like shown in the picture.
8. ➤ Stick the CPU to the profile rail right from the power supply and pull it to the power supply.

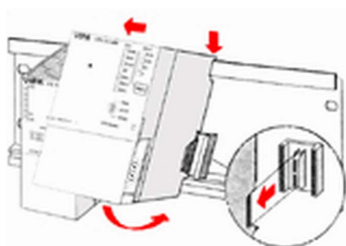

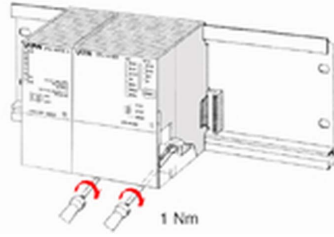

9. Click the CPU downwards and bolt it like shown.
10. Repeat this procedure with the peripheral modules, by clicking a backplane bus connector, stick the module right from the modules you've already fixed, click it downwards and connect it with the backplane bus connector of the last module and bolt it.

2.6 Cabling



CAUTION!

- The power supplies must be released before installation and repair tasks, i.e. before handling with the power supply or with the cabling you must disconnect current/voltage (pull plug, at fixed connection switch off the concerning fuse)!
- Installation and modifications only by properly trained personnel!

CageClamp technology (green)

For the cabling of power supply of a CPU, a green plug with Cage-Clamp technology is deployed. The connection clamp is realized as plug that may be clipped off carefully if it is still cabled.

Here wires with a cross-section of 0.08mm² to 2.5mm² may be connected. You can use flexible wires without end case as well as stiff wires.

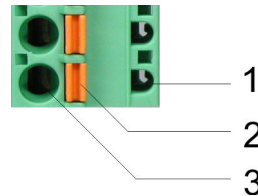

- 1 Test point for 2mm test tip
- 2 Locking (orange) for screwdriver
- 3 Round opening for wires

The picture on the left side shows the cabling step by step from top view.

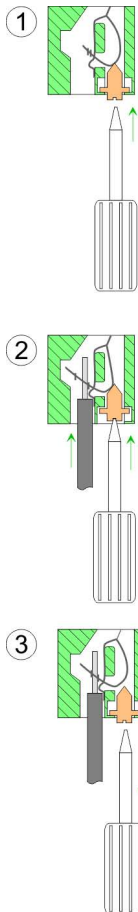

- 1. ➤ For cabling you push the locking vertical to the inside with a suitable screwdriver and hold the screwdriver in this position.
- 2. ➤ Insert the de-isolated wire into the round opening. You may use wires with a cross-section from 0.08mm² to 2.5mm²
- 3. ➤ By removing the screwdriver the wire is connected safely with the plug connector via a spring.

Front connectors of the in-/output modules

In the following the cabling of the two variants are shown.

20pole screw connection 392-1AJ00



1. ▶ Open the front flap of your I/O module.
2. ▶ Bring the front connector in cabling position.
For this you plug the front connector on the module until it locks. In this position the front connector juts out of the module and has no contact yet.
3. ▶ De-isolate your wires. If needed, use core end cases.
4. ▶ Thread the included cable binder into the front connector.
5. ▶ If you want to lead out your cables from the bottom of the module, start with the cabling from bottom to top, res. from top to bottom, if the cables should be led out at the top.
6. ▶ Bolt also the connection screws of not cabled screw clamps.

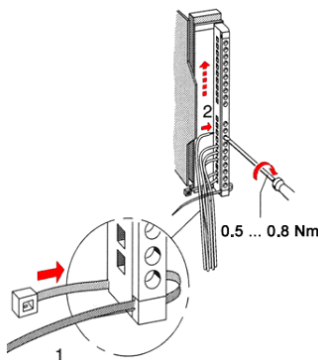

7. ▶ Fix the cable binder for the cable bundle.

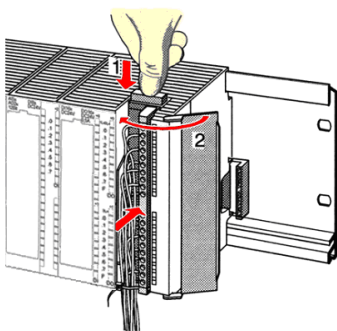

8. ▶ Push the release key at the front connector on the upper side of the module and at the same time push the front connector into the module until it locks.
9. ▶ Now the front connector is electrically connected with your module.
10. ▶ Close the front flap.
11. ▶ Fill out the labeling strip to mark the single channels and push the strip into the front flap.

40pole screw connection 392-1AM00

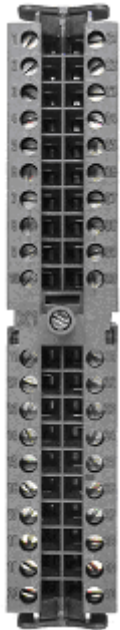

1. ▶ Open the front flap of your I/O module.
2. ▶ Bring the front connector in cabling position.
For this you plug the front connector on the module until it locks. In this position the front connector juts out of the module and has no contact yet.
3. ▶ De-isolate your wires. If needed, use core end cases.
4. ▶ If you want to lead out your cables from the bottom of the module, start with the cabling from bottom to top, res. from top to bottom, if the cables should be led out at the top.
5. ▶ Bolt also the connection screws of not cabled screw clamps.

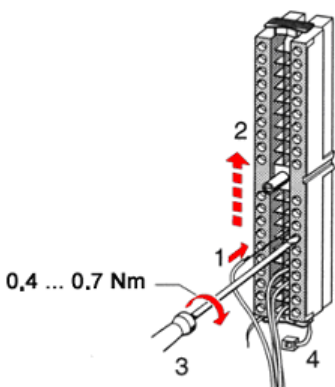

6. ▶ Put the included cable binder around the cable bundle and the front connector.
7. ▶ Fix the cable binder for the cable bundle.

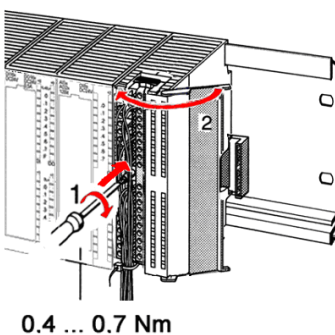

8. ▶ Bolt the fixing screw of the front connector.
9. ▶ Now the front connector is electrically connected with your module.
10. ▶ Close the front flap.
11. ▶ Fill out the labeling strip to mark the single channels and push the strip into the front flap.

2.7 Installation guidelines

General

The installation guidelines contain information about the interference free deployment of a PLC system. There is the description of the ways, interference may occur in your PLC, how you can make sure the electromagnetic compatibility (EMC), and how you manage the isolation.

- What does EMC mean?** Electromagnetic compatibility (EMC) means the ability of an electrical device, to function error free in an electromagnetic environment without being interfered respectively without interfering the environment.
- The components of VIPA are developed for the deployment in industrial environments and meets high demands on the EMC. Nevertheless you should project an EMC planning before installing the components and take conceivable interference causes into account.
- Possible interference causes** Electromagnetic interferences may interfere your control via different ways:
- Electromagnetic fields (RF coupling)
 - Magnetic fields with power frequency
 - Bus system
 - Power supply
 - Protected earth conductor
- Depending on the spreading medium (lead bound or lead free) and the distance to the interference cause, interferences to your control occur by means of different coupling mechanisms.
- There are:
- galvanic coupling
 - capacitive coupling
 - inductive coupling
 - radiant coupling
- Basic rules for EMC** In the most times it is enough to take care of some elementary rules to guarantee the EMC. Please regard the following basic rules when installing your PLC.
- Take care of a correct area-wide grounding of the inactive metal parts when installing your components.
 - Install a central connection between the ground and the protected earth conductor system.
 - Connect all inactive metal extensive and impedance-low.
 - Please try not to use aluminium parts. Aluminium is easily oxidizing and is therefore less suitable for grounding.
 - When cabling, take care of the correct line routing.
 - Organize your cabling in line groups (high voltage, current supply, signal and data lines).
 - Always lay your high voltage lines and signal respectively data lines in separate channels or bundles.
 - Route the signal and data lines as near as possible beside ground areas (e.g. suspension bars, metal rails, tin cabinet).

- Proof the correct fixing of the lead isolation.
 - Data lines must be laid isolated.
 - Analog lines must be laid isolated. When transmitting signals with small amplitudes the one sided laying of the isolation may be favourable.
 - Lay the line isolation extensively on an isolation/protected earth conductor rail directly after the cabinet entry and fix the isolation with cable clamps.
 - Make sure that the isolation/protected earth conductor rail is connected impedance-low with the cabinet.
 - Use metallic or metallised plug cases for isolated data lines.
- In special use cases you should appoint special EMC actions.
 - Consider to wire all inductivities with erase links.
 - Please consider luminescent lamps can influence signal lines.
- Create a homogeneous reference potential and ground all electrical operating supplies when possible.
 - Please take care for the targeted employment of the grounding actions. The grounding of the PLC serves for protection and functionality activity.
 - Connect installation parts and cabinets with your PLC in star topology with the isolation/protected earth conductor system. So you avoid ground loops.
 - If there are potential differences between installation parts and cabinets, lay sufficiently dimensioned potential compensation lines.

Isolation of conductors

Electrical, magnetically and electromagnetic interference fields are weakened by means of an isolation, one talks of absorption. Via the isolation rail, that is connected conductive with the rack, interference currents are shunt via cable isolation to the ground. Here you have to make sure, that the connection to the protected earth conductor is impedance-low, because otherwise the interference currents may appear as interference cause.

When isolating cables you have to regard the following:

- If possible, use only cables with isolation tangle.
- The hiding power of the isolation should be higher than 80%.
- Normally you should always lay the isolation of cables on both sides. Only by means of the both-sided connection of the isolation you achieve high quality interference suppression in the higher frequency area. Only as exception you may also lay the isolation one-sided. Then you only achieve the absorption of the lower frequencies. A one-sided isolation connection may be convenient, if:
 - the conduction of a potential compensating line is not possible.
 - analog signals (some mV respectively μA) are transferred.
 - foil isolations (static isolations) are used.
- With data lines always use metallic or metallised plugs for serial couplings. Fix the isolation of the data line at the plug rack. Do not lay the isolation on the PIN 1 of the plug bar!
- At stationary operation it is convenient to strip the insulated cable interruption free and lay it on the isolation/protected earth conductor line.

- To fix the isolation tangles use cable clamps out of metal. The clamps must clasp the isolation extensively and have well contact.
- Lay the isolation on an isolation rail directly after the entry of the cable in the cabinet. Lead the isolation further on to your PLC and don't lay it on there again!



CAUTION!

Please regard at installation!

At potential differences between the grounding points, there may be a compensation current via the isolation connected at both sides.

Remedy: Potential compensation line

2.8 General data I/O modules

Structure/dimensions

- Peripheral modules with recessed labeling
- Dimensions of the basic enclosure:
 - 1tier width: (WxHxD) in mm: 40x125x120

Reliability

- Wiring by means of spring pressure connections (CageClamps) at the front connector
- Core cross-section 0.08 ... 2.5mm² or 1.5 mm²
- Total isolation of the wiring at module change
- Potential separation of all modules to the backplane bus

2.8.1 General data

Conformity and approval		
Conformity		
CE	2014/35/EU	Low-voltage directive
	2014/30/EU	EMC directive
Approval		
UL		Refer to Technical data
others		
RoHS	2011/65/EU	Product is lead-free; Restriction of the use of certain hazardous substances in electrical and electronic equipment

Protection of persons and device protection		
Type of protection	-	IP20
Electrical isolation		

Protection of persons and device protection		
to the field bus	-	electrically isolated
to the process level	-	electrically isolated
Insulation resistance		-
Insulation voltage to reference earth		
Inputs / outputs	-	AC / DC 50V, test voltage AC 500V
Protective measures	-	against short circuit

Environmental conditions to EN 61131-2		
Climatic		
Storage / transport	EN 60068-2-14	-25...+70°C
Operation		
Horizontal installation hanging	EN 61131-2	0...+60°C
Horizontal installation lying	EN 61131-2	0...+55°C
Vertical installation	EN 61131-2	0...+50°C
Air humidity	EN 60068-2-30	RH1 (without condensation, rel. humidity 10... 95%)
Pollution	EN 61131-2	Degree of pollution 2
Installation altitude max.	-	2000m
Mechanical		
Oscillation	EN 60068-2-6	1g, 9Hz ... 150Hz
Shock	EN 60068-2-27	15g, 11ms

Mounting conditions		
Mounting place	-	In the control cabinet
Mounting position	-	Horizontal and vertical

EMC	Standard	Comment
Emitted interference	EN 61000-6-4	Class A (Industrial area)
Noise immunity zone B	EN 61000-6-2 EN 61000-4-2	Industrial area ESD 8kV at air discharge (degree of severity 3), 4kV at contact discharge (degree of severity 2)

EMC	Standard	Comment
	EN 61000-4-3	HF field immunity (casing) 80MHz ... 1000MHz, 10V/m, 80% AM (1kHz) 1.4GHz ... 2.0GHz, 3V/m, 80% AM (1kHz) 2GHz ... 2.7GHz, 1V/m, 80% AM (1kHz)
	EN 61000-4-6	HF conducted 150kHz ... 80MHz, 10V, 80% AM (1kHz)
	EN 61000-4-4	Burst, degree of severity 3
	EN 61000-4-5	Surge, installation class 3 *

*) Due to the high-energetic single pulses with Surge an appropriate external protective circuit with lightning protection elements like conductors for lightning and overvoltage is necessary.

3 Analog Input Modules

3.1 Principles

Cables for analog signals

For analog signals you have to use isolated cables to reduce interference. The cable screening should be grounded at both ends. If there are differences in the potential between the cable ends, there may occur a potential compensating current that could disturb the analog signals. In this case you should ground the cable screening only at one end.

Connecting test probes

The analog input modules provide variant connecting possibilities for:

- Current sensor
- Voltage sensor
- Resistance thermometer
- Thermocouple
- Resistors



Please take care of the correct polarity when installing the measuring transducer! Please install short circuits at non-used inputs by connecting the positive contact with the channel ground of the according channel.

Parameterization

The analog input modules from VIP A do not have any measuring range plug. The modules are parameterized via the hardware configurator or during runtime via SFCs.

Diagnostic functions

The modules that are described in this chapter except the 331-1KF01 offer diagnostics functions. The following errors may cause diagnostics:

- Error in the project engineering res. parameterization
- Wire break at current measuring
- Measuring range overstep
- Measuring range shortfall
- Common Mode Error
- Lost process interrupt
- Failure of the external power supply

For diagnostic evaluation during runtime, you may use the SFCs 51 and 59. They allow you to request detailed diagnostic information and to react to it.

3.2 Parameterization - Basics

Overview

The analog input modules from VIPA do not have any measuring range plug, so the measuring range is to be set by configuration. There are the following possibilities for parameterization:

- Parameterization by hardware configuration of Siemens SIMATIC manager or with WinPLC7 from VIPA.
- Parameterization during run time by means of SFCs.

3.2.1 Parameterization by hardware configuration

To be compatible to the Siemens SIMATIC manager the following steps are to be accomplished:

1. ▶ Start the hardware configurator from Siemens
2. ▶ Create a new project
3. ▶ Configure your CPU.
4. ▶ Link-up your System 300 modules in the plugged-in sequence starting with slot 4. Here the analog input modules of VIPA are to be projected as analog input modules of Siemens:
 - ⇒ The analog input modules can be found at the hardware catalog at *SIMATIC 300 > SM-300*.
5. ▶ If needed parameterize the CPU respectively the modules. The parameter window appears as soon as you double click on the according module. At this window the according parameter can be changed.
6. ▶ Save your project, switch the CPU to STOP and transfer your project to the CPU. As soon as the CPU is switched to RUN the parameters are transferred to the connected modules.

Parameters

The following parameters can be adjusted at the analog input modules:

- Starting address of the input data
- Measuring range, measuring type and integration time
- Diagnostics and interrupt reaction (only 331-7Kx01)

3.2.2 Parameterization during runtime

By using the SFCs 55, 56 and 57 you may change the parameters of the analog modules during runtime via the CPU. The time needed until the new parameterization is valid can last up to a few ms. During this time the measuring value 7FFFh is issued. The following example shows the assignment of record set 1 to the module 331-7Kx01 during run time.

Example

```
Var
  rec1 array [0...13] of BYTE
  retval INT
```

busy BOOL

Set Record set 1:

```

L B#16#0 //Diagnostic disabled
T #rec1[0]
L B#16#AA //Interference freq. suppression
T #rec1[1]
L B#16#D4 //Meas. range Type S: 0100b
T #rec1[2] //Meas. type: Thermocouple
T #rec1[3] //Compensation internal: 1101b
T #rec1[4] //for all channels
T #rec1[5]
L B#16#7F //Upper limit value
T #rec1[6] //channel 0: 7FFFh
L B#16#FF
T #rec1[7]
L B#16#80 //Lower limit value
T #rec1[12] //channel 2: 8000h
L B#16#00
T #rec1[13]

```

Record set 1 from module 331-7Kx01:

Byte	Bit 7 ... Bit 0
0	<ul style="list-style-type: none"> ■ Bit 5 ... 0: reserved ■ Bit 6: Diagnosis interrupt release ■ Bit 7: Process interrupt release
1	Interference freq. suppression <ul style="list-style-type: none"> ■ Bit 0, 1: Channel 0/1 ■ Bit 2, 3: Channel 2/3 ■ Bit 4, 5: Channel 4/5 ■ Bit 6, 7: Channel 6/7
2	Mode Channel 0/1 <ul style="list-style-type: none"> ■ Bit 3 ... 0: Measuring range ■ Bit 7 ... 4: Measuring type
3	Mode Channel 2/3 <ul style="list-style-type: none"> ■ Bit 3 ... 0: Measuring range ■ Bit 7 ... 4: Measuring type
4	Mode Channel 4/5 <ul style="list-style-type: none"> ■ Bit 3 ... 0: Measuring range ■ Bit 7 ... 4: Measuring type

Byte	Bit 7 ... Bit 0
5	Mode Channel 6/7 <ul style="list-style-type: none"> ■ Bit 3 ... 0: Measuring range ■ Bit 7 ... 4: Measuring type
6, 7	Upper limit value Channel 0
8, 9	Lower limit value Channel 0
10,11	Upper limit value Channel 2
12,13	Lower limit value Channel 2

Transfer with SFC 55 "WR_PARM" Record set 1 to module:

```

Call "WR_PARM" //call SFC 55
REQ :=TRUE //write request
IOID :=B#16#54 //identifier for the address space: peripheral input
LADDR :=W#16#100 //logical base address: 256
RECNUM :=B#16#1 //record number 1
RECORD :=#rec1 //record for Record set 1
RET_VAL :=#retval //return value (0: no error <> 0: error code)
BUSY :=#busy //BUSY = 1: the write operation has not been completed
    
```

Get mode

As shown in the following illustration the parameter mode is made up of the coding of the *measuring range* and *measuring type* during runtime parameterization each channel respectively channel group.

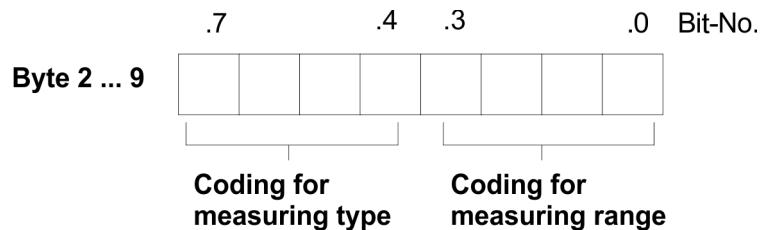

The corresponding codes can be found at parameterization of each module. The table is divided into measuring type like voltage, current, resistance measuring... . Here the corresponding binary code of the measuring type may be found. Within the measuring types there are the measuring ranges, for which a binary measuring range code is to be specified in each case.

Example

Referring to the example specified above the mode is determined in the following:

Given:

Measuring type: Thermocouple, compensation internal, linear

Measuring range: Type S

For the module 331-7Kx01 results from the table in the case of "Thermocouple with compensation internal, linear" the binary coding for measuring type: 1101b. For Measuring range "Type S" the binary measuring range coding results as: 0100b.

**CAUTION!**

Please regard that the modules described here do not have hardware precautions against wrong parameterization res. wrong wiring. The setting of the according measuring range is exclusively at the project engineering. For example, the modules may get a defect if you connect a voltage at parameterized current measuring. At the project engineering you should be very careful. Please regard also that disconnecting res. connecting during operation is not possible!

3.3 331-1KF01 - AI 8x13Bit

Properties

The analog input module transforms analog signals from the process into digital signals for the internal processing. The module is pin and function compatible to the known module from Siemens. Plugging and unplugging during operation, is not supported. Voltage and current encoders, resistors and resistor thermometers may be connected as sensors

- 8 inputs
- Measuring value resolution 12bit + sign
- Isolated to the backplane bus

Default configuration

After Power ON the module has the following default configuration. These can be changed by hardware configuration.

- measuring range: $\pm 10V$ for all channels
- integration time: 60ms

Structure

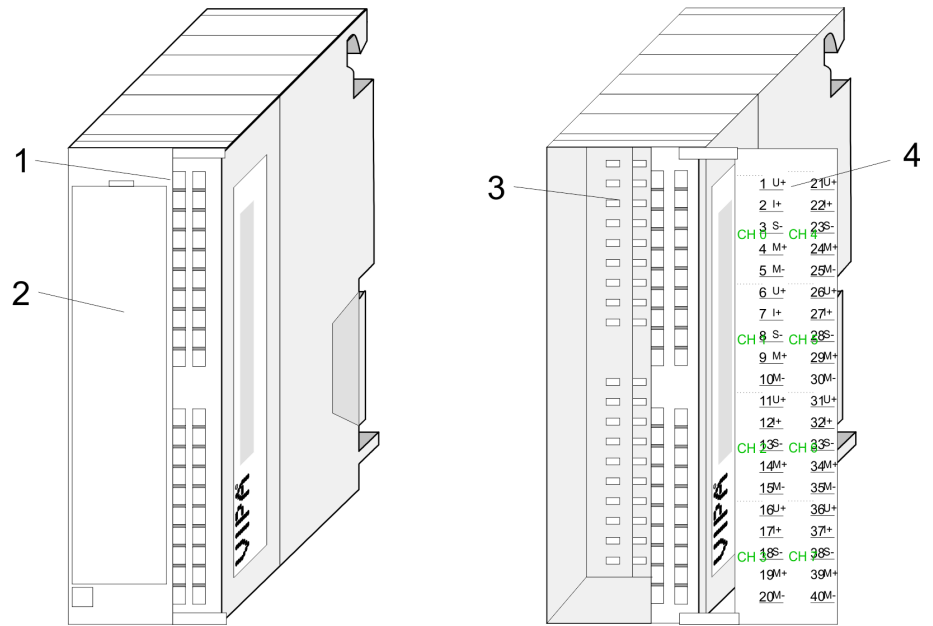

- 1 LEDs (not active)
- 2 flap with labeling strip
- 3 contact bar
- 4 flap opened with inner label

331-1KF01 - AI 8x13Bit

Pin assignment

Pin	Assignment	Connection	
1	U+ channel 0	1 U+	<p>The diagram shows a vertical module with 40 pins. The top section is labeled 'AI 8x13Bit'. Below it, there are two columns of pins. The right column is labeled 'SM331'. The module is labeled 'VIPA 331-1KF01' at the bottom. A small box at the bottom right contains the text 'x2' over '3/4'. The pin assignments are listed in the table to the left, grouped into seven channels (CH 0 to CH 7) with dashed lines separating them.</p>
2	I+ channel 0	2 I+	
3	S- channel 0	3 S-	
4	M+ channel 0	4 M+	
5	M- channel 0	5 M-	
6	U+ channel 1	6 U+	
7	I+ channel 1	7 I+	
8	S- channel 1	8 S-	
9	M+ channel 1	9 M+	
10	M- channel 1	10 M-	
11	U+ channel 2	11 U+	
12	I+ channel 2	12 I+	
13	S- channel 2	13 S-	
14	M+ channel 2	14 M+	
15	M- channel 2	15 M-	
16	U+ channel 3	16 U+	
17	I+ channel 3	17 I+	
18	S- channel 3	18 S-	
19	M+ channel 3	19 M+	
20	M- channel 3	20 M-	
21	U+ channel 4	21 U+	
22	I+ channel 4	22 I+	
23	S- channel 4	23 S-	
24	M+ channel 4	24 M+	
25	M- channel 4	25 M-	
26	U+ channel 5	26 U+	
27	I+ channel 5	27 I+	
28	S- channel 5	28 S-	
29	M+ channel 5	29 M+	
30	M- channel 5	30 M-	
31	U+ channel 6	31 U+	
32	I+ channel 6	32 I+	
33	S- channel 6	33 S-	
34	M+ channel 6	34 M+	
35	M- channel 6	35 M-	
36	U+ channel 7	36 U+	
37	I+ channel 7	37 I+	
38	S- channel 7	38 S-	
		39 M+	
		40 M-	

Pin	Assignment	Connection	
39	M+ channel 7		
40	M- channel 7		

Wiring diagrams

The following illustration shows the connection options for the different measuring ranges. The assignment to the measuring ranges is to find in the column "Conn." of the table "Measuring" on the next pages.

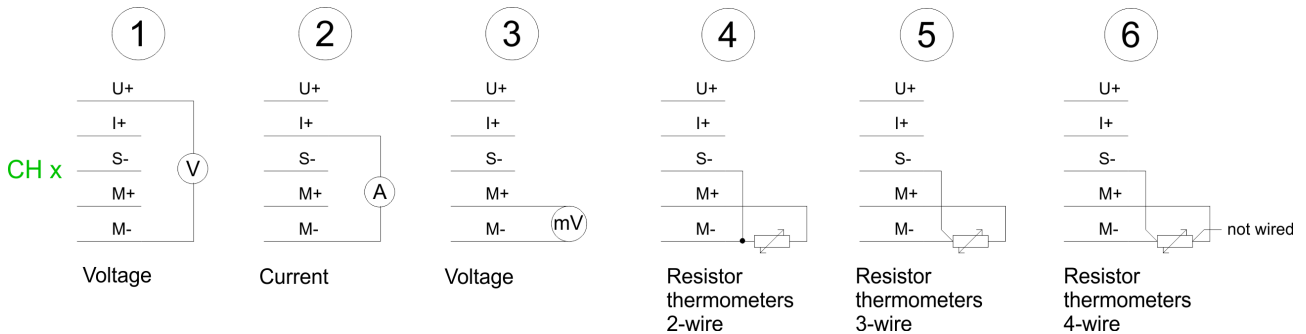

Please take care that the maximum permissible common-mode voltage of 2V between the inputs at connection of voltage and current givers is not exceeded. To avoid wrong measurements you connect the individual connections M- with each other.

At measuring of resistance and resistance thermometers a connection of the M- connections is not required. Modules are not released for common GND.

When using the temperature measurement by thermal resistance (PT100, NI100, NI1000) of the channel associated with the parameter "temperature coefficient" must be set as under "Structure parameter byte" described. ↪ Chapter 3.3.1.1 'Structure of parameter byte (Record set 1)' on page 34

Temporarily not used inputs with activated channel must be connected with the concerning ground. When not used channels are deactivated this is not necessary.

Representation of analog values

Analog values are exclusively processed by the CPU in a binary format. For this the analog module transforms every process signal into a digital and transfers this as word to the CPU. At similar nominal range, the digitalized analog value for in- and output is identical.

Resolution

Because the resolution of the module is 12Bit plus sign bit, the not used low value positions (3 Bit) are filled with "0".

For the sign bit is valid:

Bit 15 = "0" → positive value

Bit 15 = "1" → negative value

Resolu- tion	Analog value															
	High-Byte								Low-Byte							
Bit number	15	14	13	12	11	10	9	8	7	6	5	4	3	2	1	0
Value	SG	2 ¹⁴	2 ¹³	2 ¹²	2 ¹¹	2 ¹⁰	2 ⁹	2 ⁸	2 ⁷	2 ⁶	2 ⁵	2 ⁴	2 ³	2 ²	2 ¹	2 ⁰
12bit + sign	SG	Measuring value												0	0	0

3.3.1 331-1KF01 - AI 8x13Bit - Parameterization

Overview

After Power ON the module is set to ±10V for all channels with an integration time of 60ms. Via a hardware configuration you may parameterize the channels individually.

Place module

1. ➤ Start the hardware configurator with the project the analog modules are to be configured.
2. ➤ To place the analog module open the hardware catalog. There the module can be found at SIMATIC 300/SM-300/AI-300, order no.: 6ES7 331-1KF01-0AB0.
3. ➤ Choose the according module and drag & drop it to the concerning slot in the hardware configurator.

Parameterize the module

Via double click on the wanted module in the hardware configurator you open the concerning parameter window. You may alter the following parameters:

- Start address of the data of the module stored in the CPU
- Measuring range, measuring type and integration times for all of the 8 channels

Save and transfer project

- Save and compile your project
- Set your CPU to STOP
- Transfer your project into the CPU

As soon as you switch the CPU into RUN, the parameters are transmitted to the analog input module. More detailed information about the parameters can be found on the following pages.

3.3.1.1 Structure of parameter byte (Record set 1)

Record set 1

At the parameterization, a parameter area of 14byte length is stored in the record set 1. Under deploying the SFCs 55, 56 and 57, you may alter the parameters during run time and transfer them to your analog module.

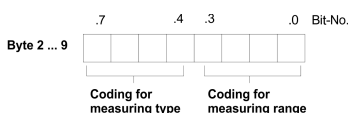

The according coding of measuring range and measuring type is described in "Mode per channel".

At temperature measurement a temperature coefficient is required. [↪ Chapter 3.3.1.2.5 'Measuring type temperature measuring' on page 40](#)

Record set 1 (Byte 0 to 13):

Byte	Bit 7 ... Bit 0
0	Temperature measuring: 0000 0000b: Grad Celsius 0000 1000b: Grad Fahrenheit 0001 0000b: Kelvin
1	Interference frequency suppression: 0000 0001b: 60Hz (<i>50ms Integration time</i>) 0000 0010b: 50Hz (<i>60ms Integration time</i>)
2	Mode channel 0 ■ Bit 3 ... 0: Measuring range ■ Bit 7 ... 4: Measuring type
3	Mode channel 1 ■ Bit 3 ... 0: Measuring range ■ Bit 7 ... 4: Measuring type
4	Mode channel 2 ■ Bit 3 ... 0: Measuring range ■ Bit 7 ... 4: Measuring type
5	Mode channel 3 ■ Bit 3 ... 0: Measuring range ■ Bit 7 ... 4: Measuring type
6	Mode channel 4 ■ Bit 3 ... 0: Measuring range ■ Bit 7 ... 4: Measuring type
7	Mode channel 5 ■ Bit 3 ... 0: Measuring range ■ Bit 7 ... 4: Measuring type
8	Mode channel 6 ■ Bit 3 ... 0: Measuring range ■ Bit 7 ... 4: Measuring type
9	Mode channel 7 ■ Bit 3 ... 0: Measuring range ■ Bit 7 ... 4: Measuring type
10	Temperature coefficient: ■ Bit 3 ... 0: channel 1 ■ Bit 7 ... 4: channel 0
11	Temperature coefficient: ■ Bit 3 ... 0: channel 3 ■ Bit 7 ... 4: channel 2

Byte	Bit 7 ... Bit 0
12	Temperature coefficient:: ■ Bit 3 ... 0: channel 5 ■ Bit 7 ... 4: channel 4
13	Temperature coefficient:: ■ Bit 3 ... 0: channel 7 ■ Bit 7 ... 4: channel 6

3.3.1.2 Measuring types and ranges

Mode per Channel

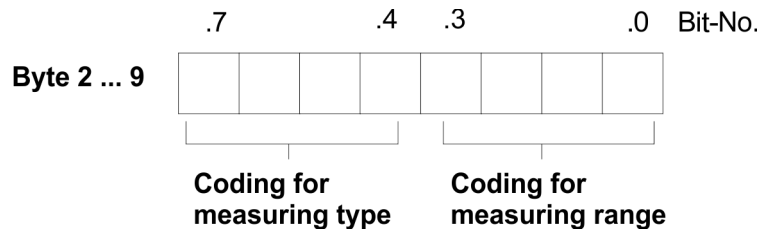

The following section shows an overview of all measuring types and ranges plus binary coding for the parameterization. Additionally, the wiring diagram assigned to the measuring range is shown in brackets.

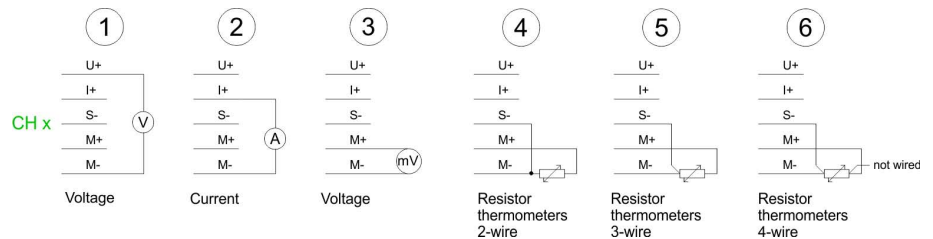

To deactivate a channel the code 0000 0000 is used.

3.3.1.2.1 Measuring type Voltage measuring

Measuring type coding: 0001b

Measuring range (Connection)	Measuring range / Representation	Measuring range coding
+/- 50mV (Connection 3)	58.79mV= End overdrive region (32511) - 50...50mV = Nominal range (-27648...27648) - 58.79mV = End underdrive region (-32512)	1011b
+/- 500mV (Connection 3)	587.9mV = End overdrive region (32511) - 500...500mV = Nominal range (-27648...27648) - 587.9mV = End underdrive region (-32512)	0011b

Measuring range (Connection)	Measuring range / Representation	Measuring range coding
+/- 1V (Connection 3)	1.176V = End overdrive region (32511) - 1...1V = Nominal range (-27648...27648) - 1.175V = End underdrive region (-32512)	0100b
+/- 5V (Connection 1)	5.879V = End overdrive region (32511) - 5...5V = Nominal range (-27648...27648) - 5.879V = End underdrive region (-32512)	0110b
1... 5V (Connection 1)	5.704V = End overdrive region (32511) 1...5V = Nominal range (0...27648) 0.296V = End underdrive region (- 4864)	0111b
0 ... 10V (Connection 1)	11.759V = End overdrive region (32511) 0...10V = Nominal range (0...27648) -1.759V = End underdrive region (- 4864)	1000b
+/- 10V (Connection 1)	11.759V = End overdrive region (32511) - 10...10V = Nominal range (-27648...27648) - 11.759V = End underdrive region (-32512)	1001b

3.3.1.2.2 Measuring type Current measuring

Measuring type coding: 0010b

Measuring range (Connection)	Measuring range / Representation	Measuring range coding
0... 20mA (Connection 2)	23.52mA = End overdrive region (32511) 0...20mA = Nominal range (0...27648) - 3.52mA = End underdrive region (-4864)	0010b
4... 20mA (Connection 2)	22.81mA = End overdrive region (32511) 4...20mA = Nominal range(0...27648) 1.185mA = End underdrive region (-4864)	0011b
+/- 20mA (Connection 2)	23.52mA = End overdrive region (32511) - 20...20mA = Nominal range (-27648...27648) - 23.52mA = End underdrive region (-32512)	0100b

3.3.1.2.3 Measuring type Resistance measuring

Measuring type coding: 0101b

Measuring range (Connection)	Measuring range / Representation	Measuring range coding
600 Ohm (Connect. 4, 5, 6)	705.53 Ohm = End overdrive region (32511) 0...600 Ohm = Nominal range (0...27648) negative values physically not possible	0010b
6000 Ohm (Connect. 4, 5, 6)	7055.3 Ohm = End overdrive region (32511) 0...6000 Ohm = Nominal range (0...27648) negative values physically not possible	0011b

3.3.1.2.4 Measuring type Thermo resistance measuring

Measuring type coding: 1001b; wiring diagram (Conn.: 4, 5, 6)

Meas. range	°C (0.1°C/ digit)	Unit dec	°F (0.1°F/ digit)	Unit dec	K (0.1K/ digit)	Unit dec	Range	Range coding
Pt100 Standard	1000.0	10000	1832.0	18320	1273.2	12732	End overdrive region	0010b
	850.0	8500	1562	15620	1123.2	11232	Nominal range	
		
	-200.0	-2000	-328.0	-3280	73.2	732	End underdrive region	
Pt100 Climate	-243.0	-2430	-405.4	-4054	30.2	302		0000b
	155.00	15500	311.00	31100	-	-	End overdrive region	
	130.00	13000	266.00	26600	-	-	Nominal range	
	-	-		
	-120.00	-12000	-184.00	-18400			End underdrive region	
	-145.00	-14500	-229.00	-22900	-	-		

Meas. range	°C (0.1°C/ digit)	Unit dec	°F (0.1°F/ digit)	Unit dec	K (0.1K/ digit)	Unit dec	Range	Range coding
Ni100 Standard	295.0	2950	563.0	5630	568.2	5682	End overdrive region	0011b
	250.0	2500	482.0	4820	523.2	5232	Nominal range	
		
	-60.0	-600	-76.0	-760	213.2	2132		
	-105.0	-1050	-157.0	-1570	168.2	1682	End underdrive region	
Ni100 Climate	295.00	29500	327.66	32766	-	-	End overdrive region	0001b
	250.00	25000	280.00	28000	-	-	Nominal range	
	-	-		
	-60.00	-6000	-76.00	7600	-	-		
	-105.00	-10500	-157.00	-15700	-	-	End underdrive region	
Ni 1000 / LG-Ni 1000 Standard	295.0	2950	563.0	5630	568.2	5682	End overdrive region	0110b
	250.0	2500	482.0	4820	523.2	5232	Nominal range	
		
	-60.0	-600	-76.0	-760	213.2	2132		
	-105.0	-1050	-157.0	-1570	168.2	1682	End underdrive region	
Ni 1000 / LG-Ni 1000 Climate	295.00	29500	327.66	32766	-	-	End overdrive region	1010b

Meas. range	°C (0.1°C/ digit)	Unit dec	°F (0.1°F/ digit)	Unit dec	K (0.1K/ digit)	Unit dec	Range	Range coding
	250.00	25000	280.00	28000	-	-	Nominal range	
				
	-60.00	-6000	-76.00	7600				
	-105.00	-10500	-157.00	-15700	-	-	End underdrive region	

When exceeding the overdrive region 32767 (7FFFh) is issued, falling below the underdrive region -32768 (8000h) is issued.

3.3.1.2.5 Measuring type temperature measuring



At temperature measurement via thermo resistance (PT100, NI100, NI1000) **always** the temperature coefficient to the according channel is required.

The table shows the according coefficient:

Measurement range	Temperature coefficient	Coding each channel
Pt 100	Pt 0.003850Ω/Ω/°C (ITS-90)	0100b
Ni100 Ni1000	Ni 0.006180Ω/Ω/°C	1000b
LG-Ni 1000	Ni 0.005000Ω/Ω/°C	1010b

3.3.2 331-1KF01 - Technical data

Order no.	331-1KF01
Type	SM 331
SPEED-Bus	-
Current consumption/power loss	
Current consumption from backplane bus	255 mA
Power loss	1.3 W
Technical data analog inputs	
Number of inputs	8

Order no.	331-1KF01
Cable length, shielded	50 m
Rated load voltage	-
Current consumption from load voltage L+ (without load)	-
Voltage inputs	✓
Min. input resistance (voltage range)	100 kΩ
Input voltage ranges	-50 mV ... +50 mV -500 mV ... +500 mV -1 V ... +1 V -5 V ... +5 V 0 V ... +10 V -10 V ... +10 V +1 V ... +5 V
Operational limit of voltage ranges	+/-0.5% ... +/-0.6%
Operational limit of voltage ranges with SFU	-
Basic error limit voltage ranges	+/-0.3% ... +/-0.4%
Basic error limit voltage ranges with SFU	-
Destruction limit voltage	max. 30V
Current inputs	✓
Max. input resistance (current range)	100 Ω
Input current ranges	-20 mA ... +20 mA 0 mA ... +20 mA +4 mA ... +20 mA
Operational limit of current ranges	+/-0.5%
Operational limit of current ranges with SFU	-
Grundfehlergrenze Strombereiche	+/-0.3%
Radical error limit current ranges with SFU	-
Destruction limit current inputs (electrical current)	max. 40mA
Destruction limit current inputs (voltage)	max. 15V
Resistance inputs	✓
Resistance ranges	0 ... 600 Ohm 0 ... 6000 Ohm
Operational limit of resistor ranges	+/-0.5%
Operational limit of resistor ranges with SFU	-

Order no.	331-1KF01
Basic error limit	+/-0.3%
Basic error limit with SFU	-
Destruction limit resistance inputs	max. 15V
Resistance thermometer inputs	✓
Resistance thermometer ranges	Pt100 Ni100 Ni1000
Operational limit of resistance thermometer ranges	+/-1K ... +/-1.2K
Operational limit of resistance thermometer ranges with SFU	-
Basic error limit thermoresistor ranges	+/-0.8K
Basic error limit thermoresistor ranges with SFU	-
Destruction limit resistance thermometer inputs	max. 15V
Thermocouple inputs	-
Thermocouple ranges	-
Operational limit of thermocouple ranges	-
Operational limit of thermocouple ranges with SFU	-
Basic error limit thermoelement ranges	-
Basic error limit thermoelement ranges with SFU	-
Destruction limit thermocouple inputs	-
Programmable temperature compensation	-
External temperature compensation	-
Internal temperature compensation	-
Temperature error internal compensation	-
Technical unit of temperature measurement	°C, °F, K
Resolution in bit	13
Measurement principle	Sigma-Delta
Basic conversion time	61 ms/51 ms / channel
Noise suppression for frequency	50 Hz/60 Hz
Initial data size	16 Byte
Status information, alarms, diagnostics	
Status display	none

Order no.	331-1KF01
Interrupts	no
Process alarm	no
Diagnostic interrupt	no
Diagnostic functions	no
Diagnostics information read-out	none
Supply voltage display	none
Group error display	none
Channel error display	none
Isolation	
Between channels	-
Between channels of groups to	-
Between channels and backplane bus	✓
Between channels and power supply	-
Max. potential difference between circuits	-
Max. potential difference between inputs (Ucm)	DC 2 V
Max. potential difference between Mana and Mintern (Uiso)	-
Max. potential difference between inputs and Mana (Ucm)	-
Max. potential difference between inputs and Mintern (Uiso)	DC 75 V/ AC 50 V
Max. potential difference between Mintern and outputs	-
Insulation tested with	DC 500 V
Datasizes	
Input bytes	16
Output bytes	0
Parameter bytes	21
Diagnostic bytes	0
Housing	
Material	PPE
Mounting	Rail System 300
Mechanical data	
Dimensions (WxHxD)	40 mm x 125 mm x 120 mm
Weight	260 g

Order no.	331-1KF01
Environmental conditions	
Operating temperature	0 °C to 60 °C
Storage temperature	-25 °C to 70 °C
Certifications	
UL certification	yes
KC certification	yes

Additional Technical data

Order number	331-1KF01	
Voltages, Currents, Potentials		
Constant current for resistance-type sensor		
- resistance thermometer and resistance measurement 0 ... 600Ω	0.83mA	
- resistance measurement 0 ... 6kΩ	0.25mA	
Analog value generation		
Integration time / conversion time / resolution (per channel)		
- programmable	yes	
- Integration time in ms	60ms	50ms
additional conversion time for measuring resistance in ms	61ms	51ms
Suppression of interference, limits error		
Noises suppression for $f=n \times (f1 \pm 1\%)$ ($f1$ =interference frequency, $n=1,2,\dots$)		
- Common-mode interference ($UCM < 2V$)	> 86dB	
- Series-mode noise (peak value of noise < nominal value of input range)	> 40dB	
Crosstalk between the inputs	> 50dB	
Temperature error (with reference to the input range)	$\pm 0.005\%/K$	
Linearity error (with reference to the input range)	$\pm 0.02\%$	
Repeatability (in steady state at 25°C, with reference to the input range)	$\pm 0.05\%$	
Data for selecting a sensor	Input range	Input resistance
- Voltage	$\pm 50mV, \pm 500mV, \pm 1V$	100MΩ

Order number	331-1KF01	
	±5V, 1...5V, ±10V, 0...10V	100kΩ
- Current	±20mA, 0...20mA, 4...20mA	100Ω
- Resistors	0 ... 600W, 0 ... 6kW	100MΩ
- Resistance thermometer	Pt100 Standard / Cli- mate	100MΩ
	Ni100, Ni1000, LG- Ni1000 Standard / Cli- mate	100MΩ
Maximum input voltage for voltage input U+ (destruction limit)	max. 30V	
Maximum input voltage for voltage input M+ (destruction limit)	max. 12V 30V for max. 1s	
Maximum input current for current input L+ (destruction limit)	40mA	
Connection of the sensors		
- for measuring voltage	possible	
- for measuring current		
as 2wire transmitter	possible, with external supply	
as 4wire transmitter	possible	
- for measuring resistance		
with 2conductor connection	possible	
with 3conductor connection	possible	
with 4conductor connection	possible	
Characteristic linearization	yes	
- for RTD	Pt100 Standard / Climate	
	Ni100, Ni1000, LG-Ni1000 Standard / Climate	
Technical unit for temperature measurement	°C/K/F	

3.4 331-7Kx01 - AI 8(2)x12Bit

Order data AI 8x12Bit (8 channel): 331-7KF01
AI 2x12Bit (2 channel): 331-7KB01

Properties

The analog input modules transform analog signals from the process into digital signals for the internal processing. The modules are pin and function compatible to the modules from Siemens with the same name. Please regard that contrary to the Siemens modules the modules specified here do not have any measuring range plug. The attitude of the designated measuring range exclusively takes place during software project engineering. Plugging and unplugging during operation, is not supported. Voltage and current sensors, thermocouples, resistors and resistance thermometers may be connected.

- 8 inputs in 4 channel group (331-7KF01)
- 2 inputs in 1 channel group (331-7KB01)
- Measuring value resolution 14Bit + sign
- Configurable diagnostic and process interrupt
- Isolated to the backplane bus

Measuring range after Power ON

After Power ON both modules have the following default configuration. These can be changed by hardware configuration:

- Measuring range: $\pm 10V$ for all channels
- Integration time: 20ms
- Interrupts deactivated

Structure

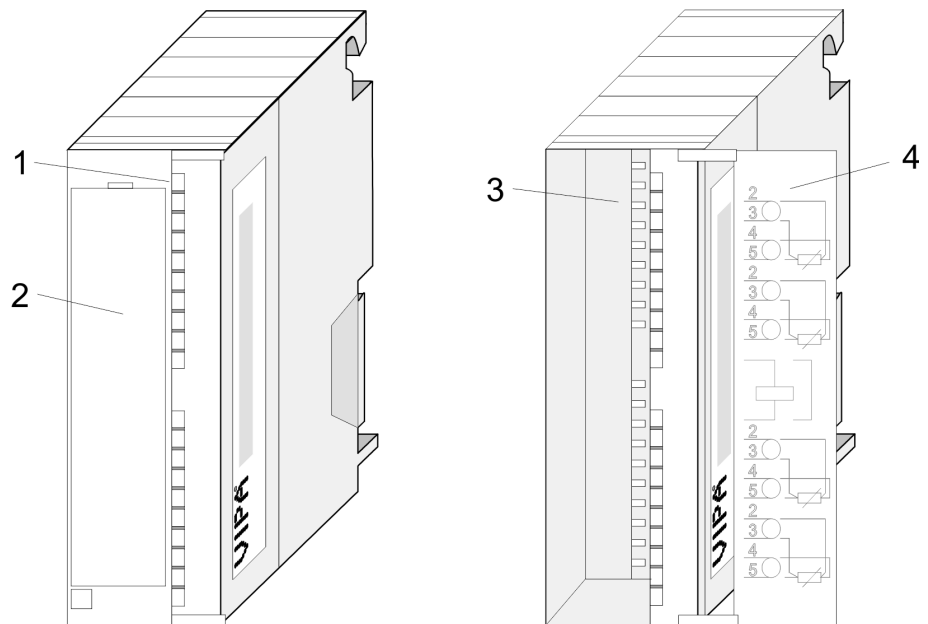

- 1 LEDs
- 2 flap with labeling strip
- 3 contact bar
- 4 flap opened with inner label

Pin assignment 331-7KF01

Pin	Assignment	Connection	331-7KF01	LED	Description	
1	Power supply DC 24V			SF	LED (red) Group error, ON as soon as a diagnostic entry is present respectively during missing external voltage supply	
2	+ Channel 0			F0	F0...7	LED (red) Channel error, ON together with SF if error respectively overflow meas- uring range per channel
3	Ground Channel 0			F1		
4	+ Channel 1			F2		
5	Ground Channel 1			F3		
6	+ Channel 2			F4		
7	Ground Channel 2			F5		
8	+ Channel 3			F6		
9	Ground Channel 3			F7		
10	+ Compensation slot			SM331		
11	Ground Compensation slot					
12	+ Channel 4					
13	Ground Channel 4					
14	+ Channel 5					
15	Ground Channel 5					
16	+ Channel 6					
17	Ground Channel 6					
18	+ Channel 7					
19	Ground Channel 7					
20	Ground					

Pin assignment LED 331-7KB01

Pin	Assignment	Connection	331-7KB01	LED	Description
1	Power supply DC 24V			SF	LED (red) Group error, ON as soon as a diagnostic entry is present respectively during missing external voltage supply
2	+ Channel 0				
3	Ground Channel 0				
4	+ Channel 1				
5	Ground Channel 1				
6	n.c.				
7					
8					
9					
10					
11					
12					
13					
14					
15					
16					
17					
18					
19					
20					
19	n.c.			F0	LED (red) Channel error, ON together with SF if error respectively overflow meas- uring range per channel
20	Ground			F1	

3.4.1 Connection of sensors

Regarding the fact, that parameterized inputs can be left unused due to the building of channel groups, you have to connect the unused inputs with the associated ground. If you want to use the internal compensation when deploying thermocouples, the 2 COMP inputs have to be bridged too. In the following all connection types of sensors for a pair of channels are specified.

Installation of current sensors

Current sensors as 2wire or 4wire measuring transducer

The 2wire measuring transducer gets the supply voltage (13V at 30mA) short-circuit resistant via the clamps of the analog input module. The 2wire measuring transducer transduces the measuring value into a current. With use of 2wire measuring transducer with a voltage >13V you may connect in line an external power supply. But here you have to deactivate the internal power supply, by selecting 4wire operation during hardware configuration.

2wire measuring transducer

The following picture illustrates the connection of 2wire measuring transducers with internal respectively external power supply:

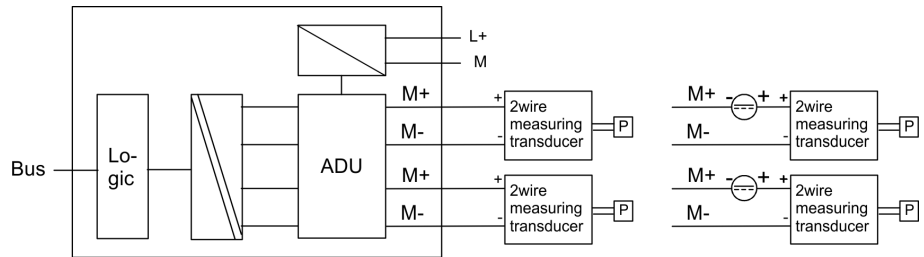

4wire measuring transducer

Please regard that the 4wire measuring transducers have to be provided external.

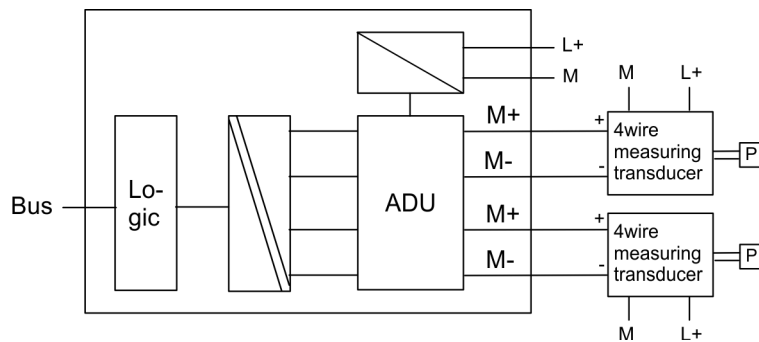

Installation of voltage sensors

The following picture shows the installation of voltage sensors at a channel pair of a potential separated analog input module:

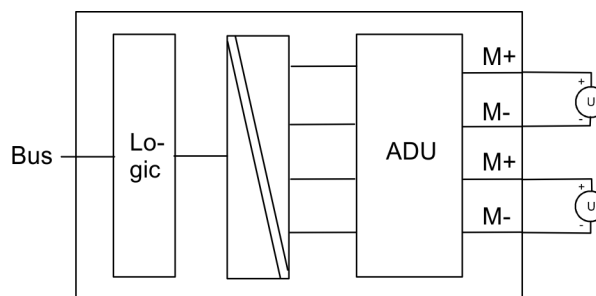

M+: measuring line (positive)

M-: measuring line (negative)

Installation of thermocouples AI 8(2)x12bit

The thermo pair consists of two wires of different metals or metal alloys which are soldered or welded together at the ends. The different combinations of metals cause different thermocouple types, e.g. K, J, N.

Operating basics

Independent from the type of the thermocouple the principle of measuring is identical for all types: When the measuring point has another temperature than the free ends of the thermo pair (connection point), a voltage occurs between the free ends, the thermo voltage. The amount of the thermo voltage depends on the difference between the temperature at the measuring point and the temperature at the free ends. For a thermo pair always records a temperature difference, the free ends have to be set on a comparison point with known temperature, to determine the temperature at the measuring point.

Extension to a comparison point

The thermo pairs may be extended from your connecting point to a point with known temperature (comparison point) via compensating lines. The compensating lines have the same material as the wires of the thermocouple. The leads are out of copper. In this case you should use the external compensation. Please regard pole correct installation, for this may cause enormous measuring errors.

Installation variants

The following pictures show the different installation possibilities of thermocouple with and without compensation slot.

Thermocouples without compensation slot and internal compensation

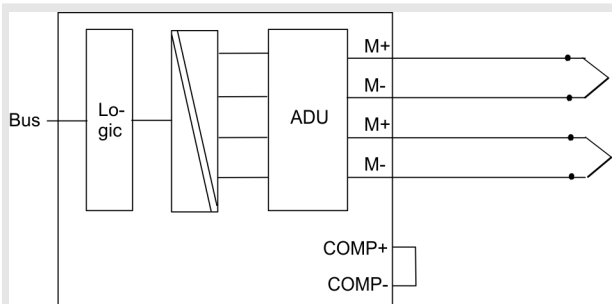

Thermocouples without compensation slot and external compensation

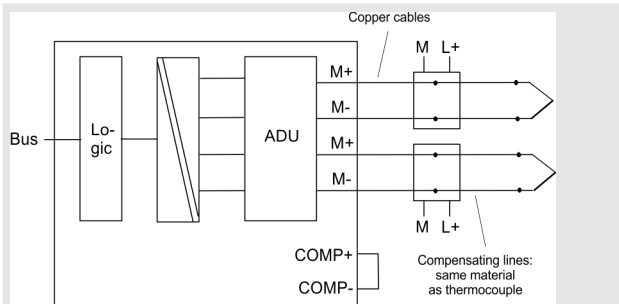

M+: measuring line (positive) COMP+: Compensation connection (positive)

M-: measuring line (negative) COMP-: Compensation connection (negative)

When connecting thermocouples without compensation slot and parameterized internal compensation, the temperature compensation happens via a temperature sensor in the module per channel pair. At external compensation, thermocouples with integrated compensation have to be used.

Thermocouples with compensation slot

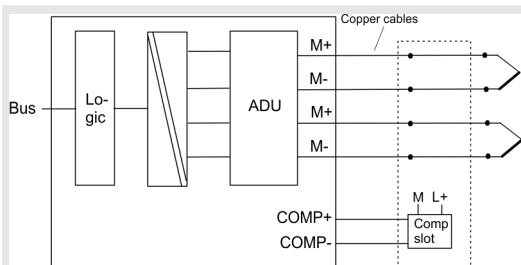

When connecting thermocouples with one compensation slot, you have to regard that the thermocouples have the same type. The compensation slot is to be connected at COMP+ and COMP- and is to be supplied external.

Installation of resistance thermometers and resistors

The installation of resistance thermometers/resistors needs 4wires. Via the connections I_{C+} and I_{C-} the resistance thermometer/resistor gets a constant current. The voltage occurring at the resistor thermometer/resistor is measured via the connections $M+$ and $M-$.

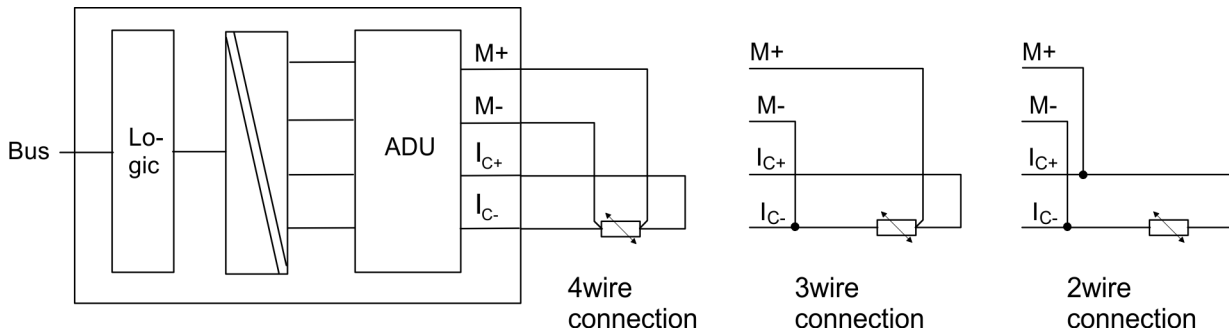

- M+: measuring line (positive)
- M-: measuring line (negative)
- I_{C+} : constant current line (positive)
- I_{C-} : constant current line (negative)

By appropriate bridges on the module between $M+$ and I_{C+} respectively $M-$ and I_{C-} you can attach also resistance thermometers in 2- and 3wire technique. Due to the not considered conduit length you have to count on losses of accuracy with the result of the measurement.

Channel allocation

At "resistance thermometers-/resistors measuring" the whole channel group (both channels) are used. The measured value can be found at the area of the 1. channel of the group. The 2. channel of the group is predefined with the overflow value "7FFFh".

Thermocouples with Pt100 reference junction (since firmware V1.3.8)

Starting with firmware version 1.3.8 of the analog module, there is the possibility to connect a Pt100 reference junction for compensation. With this connection variant the temperature of the reference junction is evaluated by means of a Pt100 resistance thermometer. For this the channel group tied up to Pt100 reference junction is to be parameterized as "Pt100 reference junction". Only one channel group may be parameterized as "Pt100 reference junction". Every channel, which is parameterized on "thermocouple with external compensation", uses the temperature of the Pt100 reference junction for evaluation. Compared to the compensating box there is the possibility to use thermocouples of different type at the same time. The temperature evaluation is more exactly than internal compensation, too. Since this variant is not supported by the Siemens SIMATIC manager, the parameterization only takes place exclusively at run time.

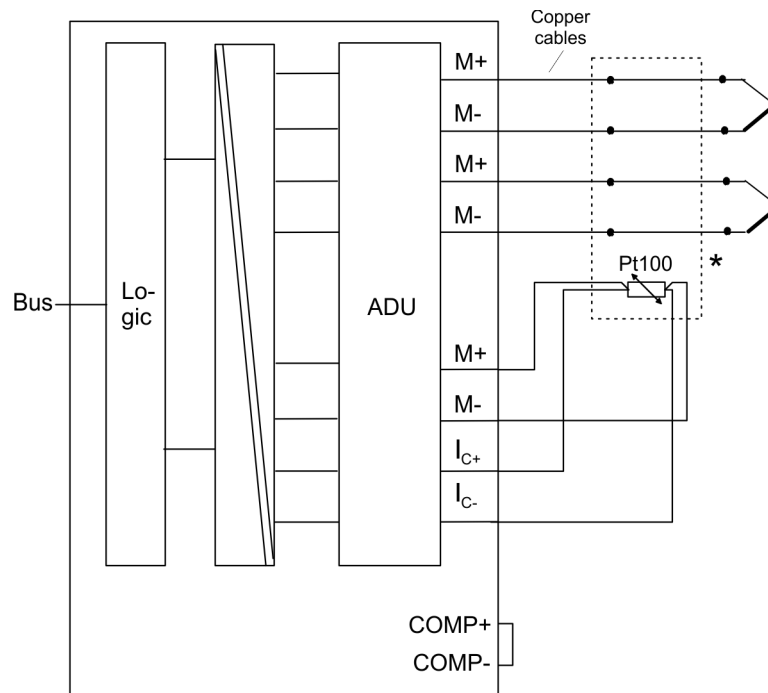

M+: measuring line (positive)

M-: measuring line (negative)

I_{C+}: constant current line (positive)

I_{C-}: constant current line (negative)

*) With a wire break at the Pt100 reference junction for evaluation, the 1. channel of one group shows the value 7FFFh.

Connection Pt100 reference junction

The installation of the Pt100 reference junction needs 4 wires. By appropriate bridges on the module between M+ and I_{C+} respectively M- and I_{C-} you also may attach Pt100 in 2- and 3wire technique. Due to the not considered conduit length you have to count on losses of accuracy with the result of the measurement. Here via the connections I_{C+} and I_{C-} the Pt resistance thermometer gets a constant current. The voltage occurring at the Pt100 resistor thermometer is measured via the connections M+ and M-.

Channel allocation

At Pt100 reference junction the whole channel group (both channels) are used. The measured value can be found at the area of the 1. channel of the group. The 2. channel of the group is predefined with the overflow value "7FFFh". Every channel, which is parameterized on "thermocouple with external compensation", uses this measuring value for evaluation even in a case of a wire break it contains the value 7FFFh.

Analog value representation

The analog values are only processed by the CPU in binary representation. Hereby the process signals are transformed into digital format in the analog module and passed on to the CPU as word variable. The digitized analog value is the same for input and output values at the same nominal range.

Resolution

The resolution of an analog value is 14bit plus sign bit. Bit 15 serves as sign bit (SG) with the meaning:

For the sign bit is valid:

- Bit 15 = "0" → positive value
- Bit 15 = "1" → negative value

Depending upon parameterized interference frequency (integration time) the modules offers different resolutions. The not used low byte bits are set to "0".

Resolu- tion	Analog value																
	High-Byte (Byte 0)								Low-Byte (Byte 1)								
Bit number	15	14	13	12	11	10	9	8	7	6	5	4	3	2	1	0	
Value	SG	2 ¹⁴	2 ¹³	2 ¹²	2 ¹¹	2 ¹⁰	2 ⁹	2 ⁸	2 ⁷	2 ⁶	2 ⁵	2 ⁴	2 ³	2 ²	2 ¹	2 ⁰	
14bit+sign	SG	Measuring value (interference frequency 10Hz)														0	
12bit+sign	SG	Measuring value (interference frequency 50Hz, 60Hz)												0	0	0	
9bit+sign	SG	Measuring value (interference frequency 400Hz)										0	0	0	0	0	0



This resolution does not apply to temperature levels. The converted temperature levels are the result of a conversion of the analog module.

Behavior at over- and underflow

As soon as a measured value exceeds the overdrive region and/or falls below the underdrive region, the following value is issued:

- Measuring value > end of overdrive region: 32767(7FFFh)
- Measuring value < end of underdrive region: -32768(8000h)

3.4.2 331-7Kx01 - AI 8(2)x12Bit - Parameterization

Overview

After power ON every channel of the modules is adjusted to ±10V with an interference frequency of 50Hz. The diagnostic function is deactivated. At the parameterization, a record set of 16byte length is transferred to both modules. Here the AI 2x12Bit (331-7KB01) uses the parameters for the channel group 0/1 the parameters for further channel groups are ignored.



Parameters which are not supported by the Siemens hardware configurator may only be changed during run time by means of SFCs.

Install module

1. ▶ Start the hardware configurator and load your project for the analog module.
2. ▶ Open the hardware catalog to install the analog input module. In the hardware catalog the analog modules with the order-no.: 6ES7 331-7KB01 (2x12Bit) and 6ES7 331-7KF01 (8x12Bit) can be found at SIMATIC 300/SM-300/AI-300.
3. ▶ Choose the according module and drag & drop this module to the concerning slot in the hardware configurator.

Parameterize the module

Via double click on the wanted module in the hardware configurator you open the concerning parameter window. You can change the following module parameters:

- Starting address for CPU mapping
- Measuring ranges, measuring type and integration times for channel pairs
- Process interrupt at limit value overflow for channel 0 and channel 2
- Limit value action at overflow
- Diagnosis and group diagnosis for each channel pair at wire break or measuring range over-/underflow.

Save and transfer your project

1. ▶ Save and translate your project.
2. ▶ Switch your CPU in STOP.
3. ▶ Transfer your project into the CPU.
4. ▶ As soon as you switch the CPU into RUN, the parameters are transmitted to the analog input module.

More information about the parameters can be found at the following pages.

3.4.2.1 Structure of the parameter bytes Record set 0, Record set 1

At the parameterization, a parameter area of 16byte length is stored in the record sets 0 and 1. Here the data irrelevant for the module AI 2x12Bit (331-7KB01) are ignored. Using the SFCs 55, 56 and 57 you can only change parameters at record set 1 and transfer during run-time to the analog module. On this way parameters may be transferred which are not supported by the Siemens SIMATIC manager, as e.g. setting of high temperature measuring ranges.

Parameter Record set 0 (not parameterizable via SFC)

Record set 0 (Byte 0 to 1):

Byte	Bit 7 ... Bit 0	Default
0	Group diagnosis bit coded <ul style="list-style-type: none"> ■ Bit 0: Channel 0/1 ■ Bit 1: Channel 2/3 ■ Bit 2: Channel 4/5 ■ Bit 3: Channel 6/7 ■ Bit 7 ... 4: reserved 	00h
1	Wire break test bit coded <ul style="list-style-type: none"> ■ Bit 0: Channel 0/1 ■ Bit 1: Channel 2/3 ■ Bit 2: Channel 4/5 ■ Bit 3: Channel 6/7 ■ Bit 7 ... 4: reserved 	00h

Parameter Record set 1
(parameterizable via SFC)

Record set 1 (Byte 0 to 13):

Byte	Bit 7 ... Bit 0	Default
0	<ul style="list-style-type: none"> ■ Bit 5 ... 0: reserved ■ Bit 6: Diagnostic interrupt release ■ Bit 7: Process interrupt release 	00h
1	Interference frequency suppression Values: <ul style="list-style-type: none"> ■ Bit 0, 1: Channel 0/1 ■ Bit 2, 3: Channel 2/3 ■ Bit 4, 5: Channel 4/5 ■ Bit 6, 7: Channel 6/7 ■ 00: 400Hz (2.5ms) ■ 01: 60Hz (16.6ms) ■ 10: 50Hz (20ms) ■ 11: 10Hz (100ms) 	AAh
2	Mode Channel 0/1 <ul style="list-style-type: none"> ■ Bit 3 ... 0: Measuring range ■ Bit 7 ... 4: Measuring type 	19h (+/-10V)
3	Mode Channel 2/3 <ul style="list-style-type: none"> ■ Bit 3 ... 0: Measuring range ■ Bit 7 ... 4: Measuring type 	19h (+/-10V)
4	Mode Channel 4/5 <ul style="list-style-type: none"> ■ Bit 3 ... 0: Measuring range ■ Bit 7 ... 4: Measuring type 	19h (+/-10V)
5	Mode Channel 6/7 <ul style="list-style-type: none"> ■ Bit 3 ... 0: Measuring range ■ Bit 7 ... 4: Measuring type 	19h (+/-10V)
6, 7	Upper limit value Channel 0	7FFFh

Byte	Bit 7 ... Bit 0	Default
8, 9	Lower limit value Channel 0	8000h
10, 11	Upper limit value Channel 2	7FFFh
12, 13	Lower limit value Channel 2	8000h

3.4.2.2 Measuring types and ranges

Modus per channel pair

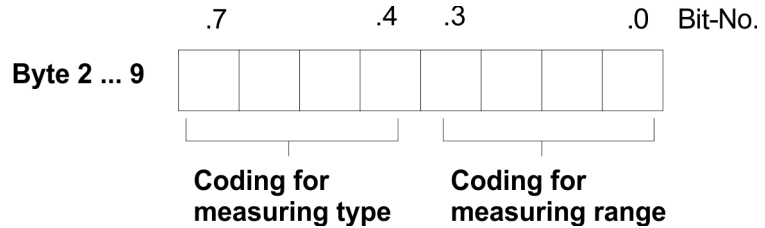

The following section shows an overview of all measuring types and ranges plus binary coding for the parameterization.



To deactivate a channel the code 0000 0000 is used.

3.4.2.2.1 Measuring type Voltage measuring

(Measuring type coding: 0001b)

Measuring range	Range / Representation	Range coding
+/- 80mV	94.071mV = End overdrive region (32511) - 80...80mV = Nominal range (-27648...27648) - 94.074mV = End underdrive region (-32512)	0001b
+/- 250mV	293.97mV = End overdrive region (32511) - 250...250mV = Nominal range (-27648...27648) - 293.98mV = End underdrive region (-32512)	0010b
+/- 500mV	587.94mV = End overdrive region (32511) - 500...500mV = Nominal range (-27648...27648) - 587.96mV = End underdrive region (-32512)	0011b
+/- 1V	1.175V = End overdrive region (32511) - 1...1V = Nominal range (-27648...27648) - 1.175V = End underdrive region (-32512)	0100b

Measuring range	Range / Representation	Range coding
+/- 2.5V	2.939V = End overdrive region (32511) - 2.5...2.5V = Nominal range (-27648...27648) - 2.933V = End underdrive region (-32512)	0101b
+/- 5V	5.879V = End overdrive region (32511) - 5...5V = Nominal range (-27648...27648) - 5.879V = End underdrive region (-32512)	0110b
+/- 10V	11.758V = End overdrive region (32511) - 10...10V = Nominal range (-27648...27648) - 11.759V = End underdrive region (-32512)	1001b
1... 5V	5.703V = End overdrive region (32511) 1...5V = Nominal range (0...27648) 0.296V = End underdrive region (- 4864)	0111b

3.4.2.2.2 Measuring type Current measuring (4wire/2wire)

4wire Current measuring (*Measuring type coding: 0010b*)

Measuring range	Range / Representation	Range coding
+/- 3.2mA	3.762mA = End overdrive region (32511) - 3.2...3.2mA = Nominal range (-27648...27648) - 3.762mA = End underdrive region (-32512)	0000b
+/- 10mA	11.758mA = End overdrive region (32511) - 10...10mA = Nominal range (-27648...27648) - 11.758mA = End underdrive region (-32512)	0001b
+/- 20mA	23.515mA = End overdrive region (32511) - 20...20mA = Nominal range (-27648...27648) - 23.515mA = End underdrive region (-32512)	0100b
0... 20mA	23.515mA = End overdrive region (32511) 0...20mA = Nominal range (0...27648) - 3.518mA = End underdrive region (-4864)	0010b
4... 20mA	22.810mA = End overdrive region (32511) 4...20mA = Nominal range (0...27648) 1.185mA = End underdrive region (-4864)	0011b

2wire Current measuring (Measuring type coding: 0011b)

Measuring range	Range / Representation	Range coding
4...20mA	22.810mA = End overdrive region (32511) 4...20mA = Nominal range (0...27648) 1.185mA = End underdrive region (-4864)	0011b

3.4.2.2.3 Measuring type 4wire Resistance measuring**Measuring type coding: 0100b**

Measuring range	Range / Representation	Range coding
150 Ohm	176.383 Ohm = End overdrive region (32511) 0...150 Ohm = Nominal range (0...27648) negative values physically not possible	0010b
300 Ohm	352.767 Ohm = End overdrive region (32511) 0...300 Ohm = Nominal range (0...27648) negative values physically not possible	0100b
600 Ohm	705.534 Ohm = End overdrive region (32511) 0...600 Ohm = Nominal range (0...27648) negative values physically not possible	0110b

3.4.2.2.4 Measuring type 4wire Thermo resistance**Measuring type coding: 1000b**

Measuring range	Range / Representation	Range coding
Pt 100 Standard	1000 = End overdrive region (10000) -200...850 = Nominal range (-2000...8500) -243 = End underdrive region (-2430) (0.1°C/digit)	0010b
Pt 100 Climate	155 = End overdrive region (15500) -120...130 = Nominal range (-12000...13000) -145 = End underdrive region (-14500) (0.01°C/digit)	0000b

Measuring range	Range / Representation	Range coding
Pt 100 reference junction	1000 = End overdrive region (10000) -100...200 = Nominal range (-1000...2000) -243 = End underdrive region (-2430) (0.1°C/digit)	1101b *2
Ni 100 Standart	295 = End overdrive region (2950) -60...250 = Nominal range (-600...2500) -105 = End underdrive region (-1050) (0.1°C/digit)	0011b *1
Ni 100 Climate	295 = End overdrive region (29500) -60...250 = Nominal range (-6000...25000) -105 = End underdrive region (-10500) (0.01°C/digit)	0001b

*1) Please use up to the firmware version V.1.2.6 of the analog module the coding 1011b. The current firmware version may be found at the front flap beneath the label strip.

*2) The measuring range Pt100 reference junction is available starting with firmware version V. 1.3.8. Since this measuring range is not supported by the Siemens SIMATIC manager, the parameterization only takes place exclusively at run time.

3.4.2.2.5 Measuring type Thermocouple

compensation external, linear (Measuring type coding: 1110b) compensation internal, linear (Measuring type coding: 1101b)

Measuring range	Range / Representation in °C (0.1°C/digit)	Range coding
Type J [Fe-Cu-Ni IEC]	1450 = End overdrive region (14500) -210 ...1200= Nominal range (-2100...12000) -210 = End underdrive region (-2100)	0101b
Type K [Ni-Cr-Ni]	1622 = End overdrive region (16220) -270 ... 1372 = Nominal range (-2700...13720) -270 = End underdrive region (-2700)	1000b
Type N [Ni-Cr-Si]	1550 = End overdrive region (15500) -270...1300 = Nominal range (-2700...13000) -270 = End underdrive region (-2700)	0001b
Type E [Ni-Cr - Cu-Ni]	1200= End Overdrive region (12000) -270...1000 = Nominal range (-2700...10000) -270 = End Underdrive region (-2700)	0010b

Measuring range	Range / Representation in °C (0.1°C/digit)	Range coding
Type L [Fe-Cu-Ni]	1150 = End overdrive region (11500) -200...900 = Nominal range (-2000...9000) -200 = End underdrive region (-2000)	0110b
Type T [Cu-Cu-Ni]	540 = End overdrive region (5400) -270...400 = Nominal range (-2700...4000) -270 = End underdrive region (-2700)	0111b *1
Type R [PtRh-Pt]	2019 = End overdrive region (20190) -50...1769 = Nominal range (-500...17690) -170 = End underdrive region (-1700)	0011b *1
Type S [PtRh-Pt]	2019 = End overdrive region (20190) -50...1769 = Nominal range (-500...17690) -170 = End underdrive region (-1700)	0100b *1
Type B [PtRh-PtRh]	2070 = End overdrive region (20700) 0...1820 = Nominal range (0...18200) -120 = End underdrive region (-1200)	0000b *1
Type C [WRe5-WRe26]	2500 = End overdrive region (25000) 0...2315 = Nominal range (0...23150) -120 = End underdrive region (-1200)	1010b *1

*1) The measuring range is available starting with firmware version V. 1.3.8. Since this measuring range is not supported by the Siemens SIMATIC manager, the parameterization only takes place exclusively at run time.

The evaluated thermo electromotive force is added to the force of the internal or external reference junction and is mapped to the 80mV measuring range.

compensation external (Measuring type coding: 1011b) compensation internal (Measuring type coding: 1010b)

Measuring range	Range / Representation	Range coding
Type J [Fe-Cu-Ni IEC]		0101b
Type K [Ni-Cr-Ni]		1000b
... and so on (see above)	94.071mV = End Overdrive region (32511) - 80...80mV = Nominal range (-27648...27648) - 94.074mV = End Underdrive region (-32512)	

Measuring range	Range / Representation	Range coding
Type C [WRe5-WRe26]		1010b *1

*1) The measuring range is available starting with firmware version V. 1.3.8. Since this measuring range is not supported by the Siemens SIMATIC manager, the parameterization only takes place exclusively at run time.

3.4.3 331-7Kx01 - AI 8(2)x12Bit - Diagnostics

As soon as an error occurs, like "wire break" or "measuring value out of range", an entry is made in the diagnostic area that can be evaluated by means of the user application. If you have released the diagnostic interrupts at the parameterization, incoming and outgoing error events are signaled by interrupts and monitored on the according analog input module via LED. At a diagnostic interrupt the CPU interrupts the user application and works off the OB 82. For more detailed diagnostic information you may call the SFC 51 res. SFC 59 in the OB 82. The diagnostic data is consistent until you leave the OB 82.

Starting the diagnosis

When an error occurs and after error correction, the diagnosis is started. Via the parameterization you fix the diagnosis behavior at error:

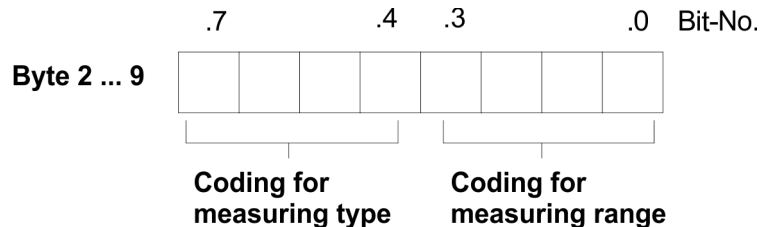

A diagnostic interrupt is only transmitted to the CPU, if you activate the diagnostic interrupt in the parameterization window. The following errors may initialize a diagnosis:

- Error in project engineering res. parameterization
- Wire break at current measuring
- Measuring range overflow
- Measuring range underflow
- Common mode error
- Lost process interrupt
- Failure of the external voltage supply

Error indication via measuring value and LEDs

Every analog input module sends, independent from the parameterization, the measuring value 7FFFh at overflow and 8000h at underflow when recognizing an error. At activated *group diagnosis* the group diagnosis-LED (SF) and the error-LED that is assigned to that channel are blinking. If you additionally activated the *wire break* diagnosis at current measuring, a wire break is shown via the error LED assigned to this channel.

Evaluating the diagnosis

At a diagnosis event the CPU interrupts the user program and branches into OB 82. This OB allows you via according programming to request detailed diagnostic information by means of the SFCs 51 and 59 and react to it. After processing of the OB 82, the processing of the user application is continued. The diagnostic data are consistent until leaving the OB 82. As soon as you have activated the diagnostic interrupt release, *record set 0* is transferred to the superordinated system in cause of an error. The *record set 0* has a fixed content and a length of 4byte. The content of *record set 0* may be monitored in plain text in the diagnosis window of the CPU. For the extended diagnosis during run time, you may also evaluate the *record set 1* of 16byte length via SFCs 51 and 59. Record set 0 and 1 have the following structure:

Diagnosis record set 0

Record set 0 (Byte 0 to 3):

Byte	Bit 7 ... Bit 0	Default
0	<ul style="list-style-type: none"> ■ Bit 0: Error in module ■ Bit 1: reserved ■ Bit 2: External error ■ Bit 3: Channel error ■ Bit 4: external voltage supply missing ■ Bit 6, 5: reserved ■ Bit 7: Wrong parameters in module 	00h
1	<ul style="list-style-type: none"> ■ Bit 3 ... 0: Module class <ul style="list-style-type: none"> – 0101b Analog module ■ Bit 4: Channel information present ■ Bit 7 ... 5: reserved 	15h
2	reserved	00h
3	<ul style="list-style-type: none"> ■ Bit 5 ... 0: reserved ■ Bit 6: Process interrupt lost ■ Bit 7: reserved 	00h

Diagnosis record set 1

Byte 0 to 15:

The record set 1 contains the 4byte of record set 0 and additionally 12byte module specific diagnostic data. The diagnostic bytes have the following assignment:

Record set 1 (Byte 0 to 15):

Byte	Bit 7 ... Bit 0	Default
0 ... 3	Content record set 0 (see page before)	-
4	<ul style="list-style-type: none"> ■ Bit 6 ... 0: Channel type <ul style="list-style-type: none"> - 70h: Digital input - 71h: Analog input - 72h: Digital output - 73h: Analog output - 74h: Analog in-/output ■ Bit 7: More channel types present <ul style="list-style-type: none"> - 0: no - 1: yes 	71h
5	<ul style="list-style-type: none"> ■ Number of diagnostic bits, that the module throws per channel 	08h
6	<ul style="list-style-type: none"> ■ Bit 7 ... 0: Number of similar channels of a module 	04h
7	<ul style="list-style-type: none"> ■ Bit 0: Channel error Channel 0 ■ ... ■ Bit 7: Channel error Channel 7 	00h
8	<ul style="list-style-type: none"> ■ Bit 0: Project engineering/Parameterization error Channel 0 ■ Bit 1: Common mode error ■ Bit 3 ... 2: reserved ■ Bit 4: Wire break Channel 0 ■ Bit 5: reserved ■ Bit 6: Underflow Channel 0 ■ Bit 7: Overflow Channel 0 	00h
...	...	
15	<ul style="list-style-type: none"> ■ Bit 0: Project engineering/Parameterization error Channel 7 ■ Bit 1: Common mode error ■ Bit 3 ... 2: reserved ■ Bit 4: Wire break Channel 7 ■ Bit 5: reserved ■ Bit 6: Underflow Channel 7 ■ Bit 7: Overflow Channel 7 	00h



Please note that the AI 2x12Bit (331-7KB01) exclusively supplies diagnostic data of the channel group 0/1!

Error cause and remedy

Message	Possible error cause	Remedial
Project engineering/ Parameterization error	Parameterization at run time: Wrong function code in record set	Proof the parameterization during run time
Wire break	Sensor allocation is too high-impedance	install another sensor type or cable with a higher cross-section
	Interruption of the conductor between module and sensor	Install conductor connection
	Channel is not wired (open)	Deactivate the channel group (parameter measuring type) Wire the channel
Measuring range underflow	Input value is under the under-drive region, error causes may be: <ul style="list-style-type: none"> ■ at measuring range 4 ... 20mA, 1 ... 5V <ul style="list-style-type: none"> – sensor connection polarity inversion – wrong measuring range ■ other measuring ranges <ul style="list-style-type: none"> – wrong measuring range 	<ul style="list-style-type: none"> - Check connections - Parameterize another measuring range - Parameterize another measuring range
Measuring range overflow	Input value higher than overdrive region	Parameterize another measuring range
Process interrupt lost	During the processing of a process interrupt in OB40, a new process interrupt with the same error cause occurs.	
Failure of the external power supply	<ul style="list-style-type: none"> - Connection of the external power supply forgotten - Power supply failure - Cable defect res. not correctly connected 	<ul style="list-style-type: none"> - Supply the module with external DC 24V - Control external power supply and change it - Control cable res. replace it
Common Mode	<ul style="list-style-type: none"> - Different potentials between grounds >3V or - Wire break at ground 	<ul style="list-style-type: none"> - Remove wire break - Lower potential difference

3.4.3.1 Process interrupts

Process interrupts are limit value interrupts. They occur if they are released via parameterization and a measuring value is outside the defined range. Process interrupts may only be parameterized for the channels 0 and 2. When a process interrupt occurs, the CPU interrupts the user application and processes the OB 40. With the help of the OB 40 you may define, how your CPU should react at a process interrupt.

Initializing the process interrupt

As soon as a measuring value is out of the range defined in the parameterization, a processes interrupt is initialized, if this option is released. Via the parameterization you define the part of the nominal range, in which the value has to be, by means of defining high and low limit. A process interrupt may only be initialized, when you have activated *hardware interrupt when limit exceeded*.

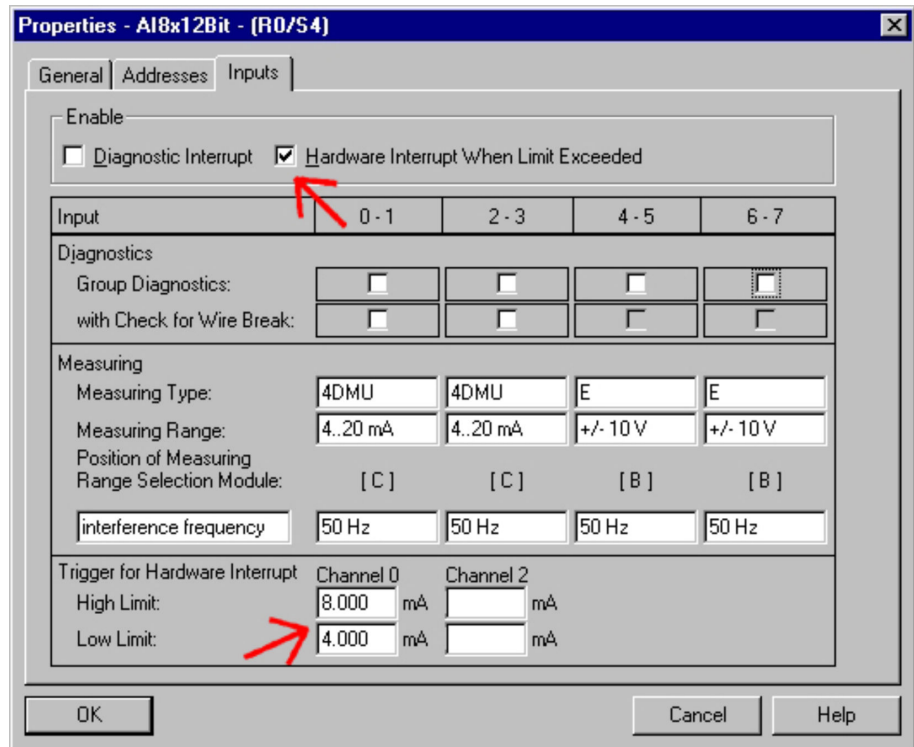

You may activate a process interrupt for channel 0 and 2. Using the default configuration, the process interrupts are not activated.

Reaction to the process interrupt

At a process interrupt the CPU interrupts the user application and branches into the OB 40. More detailed information about the channel, which limit value has been exceeded, are stored in the OB 40 in the variable OB 40_POINT_ADR in the local data double word 8 (LD 8).

The LD 8 has the following structure:

Byte	Bit 7... Bit 0
0	<ul style="list-style-type: none"> Bit: 0 = 1: Upper limit value of channel 0 has been exceeded Bit: 1 = 1: Upper limit value of channel 2 has been exceeded
1	<ul style="list-style-type: none"> Bit: 0 = 1: Lower limit value of channel 0 has been exceeded Bit: 1 = 1: Lower limit value of channel 2 has been exceeded
2 ... 3	reserved

Diagnostic message "Process interrupt lost" If a second identical process interrupt occurs during processing interrupt in OB 40, the CPU branches into the OB 82 and activates the bit 6 in record set 0 of byte 3 for "process interrupt lost". After having processed the OB 82, the CPU jumps back to OB 40.

Influence of the measuring values The behavior of the analog input module depends on the location of the measuring value inside the value range. The following table lists the different behavior:

Measuring value is in	transmitted	SF-LED *4	Diagnostics	Interrupt
Nominal range	meas. value	-	-	-
Over-/Underdrive region	meas. value	-	-	-
Overflow	7FFFh	ON *3	Entry is set *3	Diag. interrupt *1
Underflow	8000h	ON *3	Entry is set *3	Diag. interrupt *1
outside the parameterized limit value	meas. value	-	-	Process interrupt *2

*1) only if diagnostic interrupt is released in the parameterization.

*2) only if process interrupt is released in the parameterization.

*3) only if group diagnostics is released in the parameterization.

*4) independently from the chosen diagnostics, the group error LED is on when the external power supply is missing.

3.4.4 331-7KB01 - Technical data

Order no.	331-7KB01
Type	SM 331
SPEED-Bus	-
Current consumption/power loss	
Current consumption from backplane bus	95 mA
Power loss	3 W
Technical data analog inputs	
Number of inputs	2
Cable length, shielded	50 m
Rated load voltage	DC 24 V
Current consumption from load voltage L+ (without load)	100 mA
Voltage inputs	✓

Order no.	331-7KB01
Min. input resistance (voltage range)	100 k Ω
Input voltage ranges	-80 mV ... +80 mV -250 mV ... +250 mV -500 mV ... +500 mV -1 V ... +1 V -2.5 V ... +2.5 V -5 V ... +5 V +1 V ... +5 V -10 V ... +10 V
Operational limit of voltage ranges	+/-0.6% ... +/-1.0%
Operational limit of voltage ranges with SFU	-
Basic error limit voltage ranges	+/-0.4% ... +/-0.7%
Basic error limit voltage ranges with SFU	-
Destruction limit voltage	max. 15V
Current inputs	✓
Max. input resistance (current range)	85 Ω
Input current ranges	-3.2 mA ... +3.2 mA -10 mA ... +10 mA -20 mA ... +20 mA 0 mA ... +20 mA +4 mA ... +20 mA
Operational limit of current ranges	+/-0.7%
Operational limit of current ranges with SFU	-
Grundfehlergrenze Strombereiche	+/-0.5%
Radical error limit current ranges with SFU	-
Destruction limit current inputs (electrical current)	max. 40mA
Destruction limit current inputs (voltage)	max. 15V
Resistance inputs	✓
Resistance ranges	0 ... 150 Ohm 0 ... 300 Ohm 0 ... 600 Ohm
Operational limit of resistor ranges	+/-0.7%
Operational limit of resistor ranges with SFU	-
Basic error limit	+/-0.5%

Order no.	331-7KB01
Basic error limit with SFU	-
Destruction limit resistance inputs	max. 15V
Resistance thermometer inputs	✓
Resistance thermometer ranges	Pt100 Ni100
Operational limit of resistance thermometer ranges	+/-0.7% ... +/-0.8%
Operational limit of resistance thermometer ranges with SFU	-
Basic error limit thermoresistor ranges	+/-0.5% ... +/-0.6%
Basic error limit thermoresistor ranges with SFU	-
Destruction limit resistance thermometer inputs	max. 15V
Thermocouple inputs	✓
Thermocouple ranges	type J type R type K type N type L type E type T type S type B type C
Operational limit of thermocouple ranges	+/-1.3% ... +/-2.0%
Operational limit of thermocouple ranges with SFU	-
Basic error limit thermoelement ranges	+/-0.7% ... +/-1.0%
Basic error limit thermoelement ranges with SFU	-
Destruction limit thermocouple inputs	max. 15V
Programmable temperature compensation	✓
External temperature compensation	✓
Internal temperature compensation	✓
Temperature error internal compensation	3 K
Technical unit of temperature measurement	°C
Resolution in bit	14

Order no.	331-7KB01
Measurement principle	Sigma-Delta
Basic conversion time	4 ms/18 ms/22 ms/68 ms / channel
Noise suppression for frequency	1300 Hz/190 Hz/150 Hz/50 Hz + 60 Hz
Initial data size	4 Byte
Status information, alarms, diagnostics	
Status display	none
Interrupts	yes
Process alarm	yes, parameterizable
Diagnostic interrupt	yes, parameterizable
Diagnostic functions	yes
Diagnostics information read-out	possible
Supply voltage display	none
Group error display	red SF LED
Channel error display	red LED per channel
Isolation	
Between channels	-
Between channels of groups to	-
Between channels and backplane bus	✓
Between channels and power supply	✓
Max. potential difference between circuits	-
Max. potential difference between inputs (Ucm)	DC 3 V
Max. potential difference between Mana and Mintern (Uiso)	DC 75 V/ AC 50 V
Max. potential difference between inputs and Mana (Ucm)	DC 3 V
Max. potential difference between inputs and Mintern (Uiso)	-
Max. potential difference between Mintern and outputs	-
Insulation tested with	DC 500 V
Datasizes	
Input bytes	4
Output bytes	0
Parameter bytes	21
Diagnostic bytes	16

Order no.	331-7KB01
Housing	
Material	PPE
Mounting	Rail System 300
Mechanical data	
Dimensions (WxHxD)	40 mm x 125 mm x 120 mm
Weight	220 g
Environmental conditions	
Operating temperature	0 °C to 60 °C
Storage temperature	-25 °C to 70 °C
Certifications	
UL certification	yes
KC certification	yes

Additional Technical data

Order number	331-7KB01			
Data for specific module				
Number of inputs for 4wire resistance-type sensor	1			
Voltages, Currents, Potentials				
Power supply of the transmitters				
- Supply voltage	13V at 30mA			
- Supply current	max. 30mA (per channel)			
- Short-circuit-proof	yes			
Constant current for resistance-type sensor	2.25mA			
Analog value generation				
Integration - /conversion time/resolution (per channel)				
- programmable	yes			
- Conversion rate in Hz	400	60	50	10
- Integration time in ms	2.5	16 ^{2/3}	20	100
- Basic conversion time in ms	4	18	22	68
Additional conversion time for open circuit monitoring in ms	4ms			
- Resolution (incl. overrange) in Bit	9	12	12	14
- Noise suppression for frequency f1 in Hz	-	-	-	50/60

Order number	331-7KB01			
- Basic execution time of the module in ms (all channels enabled)	18	46	54	146
Smoothing of the measured values	none			
Suppression of interference, limits error				
Noises suppression for $f=n \times (f1 \pm 1\%)$ ($f1$ =interference frequency, $n=1, 2, \dots$)				
- Common-mode interference ($U_{CM} < 3V$)	> 70dB			
- Series-mode noise (peak value of noise < nominal value of input range)	> 40dB			
Crosstalk between the inputs	> 50dB			
Temperature error (with reference to the input range)	$\pm 0.005\%/K$			
Linearity error (with reference to the input range)	$\pm 0.02\%$			
Repeatability (in steady state at 25°C, with reference to the input range)	$\pm 0.05\%$			
Temperature error of internal compensation	$\pm 1.5\%$			
Data for selecting a sensor				
	Input resistance			
- Voltage				
$\pm 80mV, \pm 250mV$	10M Ω			
$\pm 500mV, \pm 1V$	10M Ω			
$\pm 2,5V, \pm 5V$	100k Ω			
1 ... 5V, $\pm 10V$	100k Ω			
- Current				
$\pm 3,2mA, \pm 10mA, \pm 20mA$	85 Ω			
0 ... 20mA, 4 ... 20mA	85 Ω			
- Resistance				
0 ... 150W, 300W, 600W	10M Ω			
- Resistance thermometer				
Pt100, NI100	10M Ω			
- Thermocouples				
Type J, K, N, L, E, T, S, B, C, R	10M Ω			
Maximum input voltage for voltage input (destruction limit)	max. 20V			
Maximum input current for current input (destruction limit)	max. 40mA			

Order number	331-7KB01
Connection of the sensors	
- for measuring voltage	possible
- for measuring current	
as 2wire transmitter	possible
as 4wire transmitter	possible
- for measuring resistance	
with 2conductor connection	possible
with 3conductor connection	possible
with 4conductor connection	possible
Characteristic linearization	
- for RTD	Pt100, NI 100 Standard / Climate
- for thermocouples	Type E, N, J, K, L, T, S, B, C, R, Ni100 Standard / Climate
Temperature compensation	parameterizable
- internal temperature compensation	possible
- external temperature compensation with compensating box	possible
- Compensation for 0°C comparison point temperature	possible
Technical unit for temperature measurement	°C

Thermocouple for high temperature measurement

The thermocouples for high temperature measurement (Type S, B, C, R) produce physically caused smaller thermo electromotive forces than the "normal" thermocouples (Type E, N, J, K, L). In the following table there is a comparison between the thermo electromotive forces of the thermocouple of the type N to type S, B, C, R.

Thermo electromotive forces of Thermocouples	0°C	500°C	1000°C	1700°C
Type N in $\mu\text{V} / ^\circ\text{C}$	26	38	39	not possible
Type S in $\mu\text{V} / ^\circ\text{C}$	5	10	12	12
Type B in $\mu\text{V} / ^\circ\text{C}$	0	5	9	11
Type C in $\mu\text{V} / ^\circ\text{C}$	13	19	18	14
Type R in $\mu\text{V} / ^\circ\text{C}$	5	11	13	13

3.4.5 331-7KF01 - Technical data

Order no.	331-7KF01
Type	SM 331
SPEED-Bus	-
Current consumption/power loss	
Current consumption from backplane bus	95 mA
Power loss	3 W
Technical data analog inputs	
Number of inputs	8
Cable length, shielded	50 m
Rated load voltage	DC 24 V
Current consumption from load voltage L+ (without load)	100 mA
Voltage inputs	✓
Min. input resistance (voltage range)	100 kΩ
Input voltage ranges	-80 mV ... +80 mV -250 mV ... +250 mV -500 mV ... +500 mV -1 V ... +1 V -2.5 V ... +2.5 V -5 V ... +5 V +1 V ... +5 V -10 V ... +10 V
Operational limit of voltage ranges	+/-0.6% ... +/-1.0%
Operational limit of voltage ranges with SFU	-
Basic error limit voltage ranges	+/-0.4% ... +/-0.7%
Basic error limit voltage ranges with SFU	-
Destruction limit voltage	max. 15V
Current inputs	✓
Max. input resistance (current range)	85 Ω
Input current ranges	-3.2 mA ... +3.2 mA -10 mA ... +10 mA -20 mA ... +20 mA 0 mA ... +20 mA +4 mA ... +20 mA
Operational limit of current ranges	+/-0.7%

Order no.	331-7KF01
Operational limit of current ranges with SFU	-
Grundfehlergrenze Strombereiche	+/-0.5%
Radical error limit current ranges with SFU	-
Destruction limit current inputs (electrical current)	max. 40mA
Destruction limit current inputs (voltage)	max. 15V
Resistance inputs	✓
Resistance ranges	0 ... 150 Ohm 0 ... 300 Ohm 0 ... 600 Ohm
Operational limit of resistor ranges	+/-0.7%
Operational limit of resistor ranges with SFU	-
Basic error limit	+/-0.5%
Basic error limit with SFU	-
Destruction limit resistance inputs	max. 15V
Resistance thermometer inputs	✓
Resistance thermometer ranges	Pt100 Ni100
Operational limit of resistance thermometer ranges	+/-0.7% ... +/-0.8%
Operational limit of resistance thermometer ranges with SFU	-
Basic error limit thermoresistor ranges	+/-0.5% ... +/-0.6%
Basic error limit thermoresistor ranges with SFU	-
Destruction limit resistance thermometer inputs	max. 15V
Thermocouple inputs	✓

Order no.	331-7KF01
Thermocouple ranges	type J type R type K type N type L type E type T type S type B type C
Operational limit of thermocouple ranges	+/-1.3% ... +/-2.0%
Operational limit of thermocouple ranges with SFU	-
Basic error limit thermoelement ranges	+/-0.7% ... +/-1.0%
Basic error limit thermoelement ranges with SFU	-
Destruction limit thermocouple inputs	max. 15V
Programmable temperature compensation	✓
External temperature compensation	✓
Internal temperature compensation	✓
Temperature error internal compensation	3 K
Technical unit of temperature measurement	°C
Resolution in bit	14
Measurement principle	Sigma-Delta
Basic conversion time	4 ms/18 ms/22 ms/68 ms / channel
Noise suppression for frequency	1300 Hz/190 Hz/150 Hz/50 Hz + 60 Hz
Initial data size	16 Byte
Status information, alarms, diagnostics	
Status display	none
Interrupts	yes
Process alarm	yes, parameterizable
Diagnostic interrupt	yes, parameterizable
Diagnostic functions	yes
Diagnostics information read-out	possible
Supply voltage display	none

Order no.	331-7KF01
Group error display	red SF LED
Channel error display	red LED per channel
Isolation	
Between channels	-
Between channels of groups to	-
Between channels and backplane bus	✓
Between channels and power supply	✓
Max. potential difference between circuits	-
Max. potential difference between inputs (Ucm)	DC 3 V
Max. potential difference between Mana and Mintern (Uiso)	DC 75 V/ AC 50 V
Max. potential difference between inputs and Mana (Ucm)	DC 3 V
Max. potential difference between inputs and Mintern (Uiso)	-
Max. potential difference between Mintern and outputs	-
Insulation tested with	DC 500 V
Datasizes	
Input bytes	16
Output bytes	0
Parameter bytes	21
Diagnostic bytes	16
Housing	
Material	PPE
Mounting	Rail System 300
Mechanical data	
Dimensions (WxHxD)	40 mm x 125 mm x 120 mm
Weight	240 g
Environmental conditions	
Operating temperature	0 °C to 60 °C
Storage temperature	-25 °C to 70 °C
Certifications	
UL certification	yes
KC certification	yes

Additional Technical data

Order number	331-7KF01			
Data for specific module				
Number of inputs for 4wire resistance-type sensor	4			
Voltages, Currents, Potentials				
Power supply of the transmitters				
- Supply voltage	13V at 30mA			
- Supply current	max. 30mA (per channel)			
- Short-circuit-proof	yes			
Constant current for resistance-type sensor	2.25mA			
Analog value generation				
Integration - /conversion time/resolution (per channel)				
- programmable	yes			
- Conversion rate in Hz	400	60	50	10
- Integration time in ms	2.5	16 ^{2/3}	20	100
- Basic conversion time in ms	4	18	22	68
Additional conversion time for open circuit monitoring in ms				
- Resolution (incl. overrange) in Bit	9	12	12	14
- Noise suppression for frequency f1 in Hz	-	-	-	50/60
- Basic execution time of the module in ms (all channels enabled)	42	154	186	554
Smoothing of the measured values	none			
Suppression of interference, limits error				
Noises suppression for $f=n \times (f1 \pm 1\%)$ (f1=interference frequency, n=1, 2,...)				
- Common-mode interference ($U_{CM} < 3V$)	> 70dB			
- Series-mode noise (peak value of noise < nominal value of input range)	> 40dB			
Crosstalk between the inputs	> 50dB			
Temperature error (with reference to the input range)	$\pm 0.005\%/K$			
Linearity error (with reference to the input range)	$\pm 0.02\%$			
Repeatability (in steady state at 25°C, with reference to the input range)	$\pm 0.05\%$			

Order number	331-7KF01
Temperature error of internal compensation	±1.5%
Data for selecting a sensor	
	Input range
- Voltage	
± 80mV, ± 250mV	10MΩ
± 500mV, ± 1V	10MΩ
± 2,5V, ± 5V	100kΩ
1 ... 5V, ± 10V	100kΩ
- Current	
± 3,2mA, ± 10mA, ± 20mA	85Ω
0 ... 20mA, 4 ... 20mA	85Ω
- Resistors	
0 ... 150Ω, 300Ω, 600Ω	10MΩ
- Resistance thermometer	
Pt100, NI100	10MΩ
- Thermocouples	
Type J, K, N, L, E, T, S, B, C, R	10MΩ
Maximum input voltage for voltageinput (destruction limit)	max. 20V
Maximum input current for currentinput (destruction limit)	max. 40mA
Connection of the sensors	
- for measuring voltage	possible
- for measuring current	
as 2wire transmitter	possible
as 4wire transmitter	possible
- for measuring resistance	
with 2conductor connection	possible
with 3conductor connection	possible
with 4conductor connection	possible
Characteristic linearization	
- for RTD	Pt100, NI 100 Standard / Climate
- for thermocouples	Typ E, N, J, K, L, T, S, B, C, R, Ni100 Standard / Climate
Temperature compensation	parameterizable

Order number	331-7KF01
- internal temperature compensation	possible
- external temperature compensation with compensating box	possible
- Compensation for 0°C comparison point temperature	possible
Technical unit for temperature measurement	°C

Thermocouple for high temperature measurement

The thermocouples for high temperature measurement (Type S, B, C, R) produce physically caused smaller thermo electromotive forces than the "normal" thermocouples (Type E, N, J, K, L). In the following table there is a comparison between the thermo electromotive forces of the thermocouple of the type N to type S, B, C, R.

Thermo electromotive forces of Thermocouples	0°C	500°C	1000°C	1700°C
Type N in $\mu\text{V} / ^\circ\text{C}$	26	38	39	not possible
Type S in $\mu\text{V} / ^\circ\text{C}$	5	10	12	12
Type B in $\mu\text{V} / ^\circ\text{C}$	0	5	9	11
Type C in $\mu\text{V} / ^\circ\text{C}$	13	19	18	14
Type R in $\mu\text{V} / ^\circ\text{C}$	5	11	13	13

4 Analog Output Modules

4.1 General

Cables for analog signals

For analog signals you should use isolated cables to reduce interference. The cable screening should be grounded at both ends. If there are differences in the potential between the cable ends, there may occur a potential compensating current that could disturb the analog signals. In this case you should ground the cable screening only at one end.

Connecting loads and actuators

Depending on the module the following actuators may be connected:

- Current input: $\pm 20\text{mA}$, 4 ... 20mA, 0 ... 20mA
- Voltage input: $\pm 10\text{V}$, 1 ... 5V, 0 ... 10V



Please take always care of the correct polarity when connecting actuators! Please leave the output pins of not used channels disconnected and configure the output type of the channel to "deactivated".

Parameterization

The modules can be configured by means of a hardware configuration or rather during run time by SFCs. In not parameterized status, the modules with order number 332-5Hx01 are set to voltage output " $\pm 10\text{V}$ ". The interrupt output of every module is deactivated.

Diagnostic functions

Every module described here has diagnostic functions. Depending on the module the following errors may initialize a diagnostic message: A diagnostic interrupt is only transmitted to the CPU, if you have activated the diagnostic interrupt in the parameterization window. The following errors a diagnosis:

- Wire break at current output (only 332-5Hx01)
- Ground short circuit (only 332-5Hx01)
- Operate the front switch (only 332-5HDx0)
- Failure of the external voltage supply
- Project engineering and parameterization error

For more detailed diagnostic information you may call the SFCs 51 and 59 during run time. You can request detailed diagnostic information and react on it by means of the SFCs.

Output pulse at Power ON/OFF and at output range alterations during run time

System-dependently at switching on/off the power supply and at output range alterations during run time, there may arise wrong values for app. 10ms.

4.2 Connecting loads and actuators

Connecting loads at current output

Loads at the current output have to be connected at Q_x and associated ground M_x of the analog circuit. Please always pay attention to correct polarity.

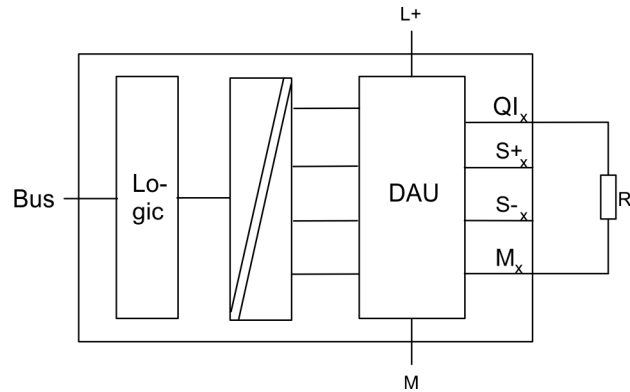

Connecting loads at voltage output at 4-wire cabling (only 332-5Hx01)

The connection of a load at a voltage output can take place both in 2- and in 4-wire cabling. Please note with the modules 332-5HDx0 the 4-wire cabling is not possible. With 4-wire cabling you achieve a high exactness at the load. The sensor lines $S+_x$ and $S-_x$ are directly connected to the load. Thus, the voltage may be measured and adjusted directly at the load. Interference or voltage losses may cause potential differences between $S-_x$ and M_x . These should not exceed the permissible value of DC 3V, because this may disturb the accuracy of the analog signal.

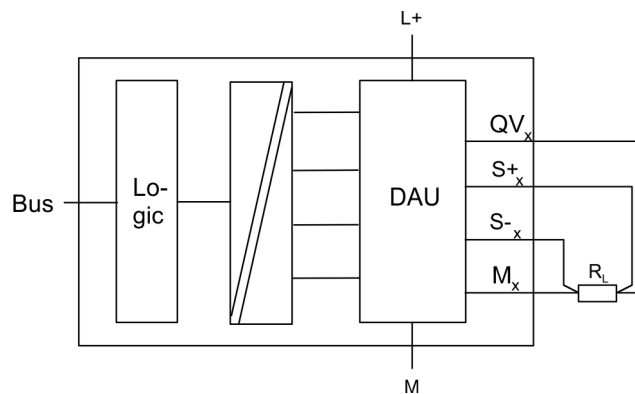

Connecting loads at voltage output at 2-wire cabling

Connect the load at pin QV_x and the point of reference of the measuring circle M_x ($x = \text{No. of the channel}$).

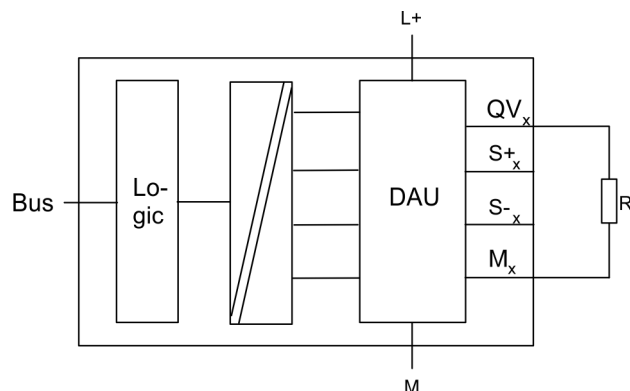

4.3 Analog value representation

Analog value representation

The analog values are only processed by the CPU in binary representation. Hereby the process signals are transformed into digital format in the analog module and passed on to the CPU as word variable. The digitized analog value is the same for input and output values at the same nominal range. The resolution depends on the used module as follows:

Resolution	Analog value															
	High-Byte (Byte 0)								Low-Byte (Byte 1)							
Bit number	15	14	13	12	11	10	9	8	7	6	5	4	3	2	1	0
Resolution	SG	Analog value (word)														
12bit+Sign	SG	Relevant output value														X
11bit+Sign	SG	Relevant output value												X	X	X
10bit+Sign	SG	Relevant output value									X	X	X	X	X	X

*) The least significant irrelevant bits of the output value are marked by "X".

Sign bit (SG)

The algebraic sign bit is represented by Bit 15. Here it is essential:

- Bit 15 = "0" → positive value
- Bit 15 = "1" → negative value

4.4 Parameterization - Basics

Overview

There are the following possibilities for parameterization:

- Parameterization by hardware configuration of Siemens SIMATIC manager or with WinPLC7 from VIPA.
- Parameterization during run time by means of SFCs.

4.4.1 Parameterization by hardware configuration

To be compatible to the Siemens SIMATIC manager the following steps are to be accomplished:

1. ▶ Start the hardware configurator from Siemens
2. ▶ Create a new project
3. ▶ Configure your CPU.

4. ▶ Link-up your System 300V modules in the plugged-in sequence starting with slot 4.
 - ⇒ Here the analog output modules of VIPA are to be projected as analog output modules of Siemens in accordance with the following rules:
 - VIPA 332-5HD01, VIPA 332-5HDx0** to be configured as **6ES7 332-5HD01-0AB0**
 - VIPA 332-5HB01** to be configured as **6ES7 332-5HB01-0AB0**
- The analog output modules can be found at the hardware catalog at *Simatic 300 > SM-300*.
5. ▶ If needed parameterize the CPU respectively the modules. The parameter window appears as soon as you double click on the according module. At this window the according parameter can be changed.
 6. ▶ Save your project, switch the CPU to STOP and transfer your project to the CPU. As soon as the CPU is switched to RUN the parameters are transferred to the connected modules.

Parameters

The following parameters can be adjusted at the analog output modules:

- Starting address of the output data
- Output type and behavior
- Reaction at CPU-STOP
- Diagnostics and interrupt reaction

A closer description of the parameters can be found at the following pages.

4.4.2 Parameterization during run time by means of SFCs

If the module gets parameters, which are not supported by the module, for example a current module is to be configured as a voltage module, these parameters are interpreted as wrong parameters and an error is initialized. At the parameterization, 16byte long parameter area is set in the record sets 0 and 1. Deploying the SFCs 55, 56 and 57, you may alter parameters during run time and transfer them to the module. The following tables show the structure of the parameters in record set 0 and 1:

Parameters Record set 0 (not parameterizable via SFC)

Record set 0 (Byte 0 to 1):

Byte	Bit 7 ... Bit 0	Default
0	Sum diagnosis bit coded <ul style="list-style-type: none"> ■ Bit 0: Channel 0 ■ Bit 1: Channel 1 ■ Bit 2: Channel 2 ■ Bit 3: Channel 3 ■ Bit 7 ... 4: reserved 	00h
1	reserved	00h

Parameters Record set 1

Record set 1 (Byte 0 to 13):		Default			
Byte	Bit 7 ... Bit 0	332-5Hx01	332-5HD50	332-5HD60	
0	<ul style="list-style-type: none"> ■ Bit 5 ... 0: reserved ■ Bit 6: Diagnostic interrupt release ■ Bit 7: reserved 	00h	00h	00h	
1	Reaction at CPU-STOP <ul style="list-style-type: none"> ■ Bit 0: Channel 0 ■ Bit 1: Channel 1 ■ Bit 2: Channel 2 ■ Bit 3: Channel 3 	0: Switch output current and voltage free res. set replacement value 1: hold last value	00h	00h	00h
2	Mode Channel 0 <ul style="list-style-type: none"> ■ Bit 3 ... 0: Output range ■ Bit 7 ... 4: Output type 	19h (+/-10V)	23h (4...20mA)	18h (0...10V)	
3	Mode Channel 1 <ul style="list-style-type: none"> ■ Bit 3 ... 0: Output range ■ Bit 7 ... 4: Output type 	19h (+/-10V)	23h (4...20mA)	18h (0...10V)	
4	Mode Channel 2 <ul style="list-style-type: none"> ■ Bit 3 ... 0: Output range ■ Bit 7 ... 4: Output type 	19h (+/-10V)	23h (4...20mA)	18h (0...10V)	
5	Mode Channel 3 <ul style="list-style-type: none"> ■ Bit 3 ... 0: Output range ■ Bit 7 ... 4: Output type 	19h (+/-10V)	23h (4...20mA)	18h (0...10V)	
6, 7	Replacement value Channel 0	0000h	0000h	0000h	
8, 9	Replacement value Channel 1	0000h	0000h	0000h	
10, 11	Replacement value Channel 2	0000h	0000h	0000h	
12, 13	Replacement value Channel 3	0000h	0000h	0000h	



With setting the mode parameter to 00h the according channel is deactivated. To switch at not symmetric output range the current respectively the voltage output to 0 value at CPU STOP, the following replacement values should be used:

output range 1...5V: 0V ↔ -6912dec = E500h

output range 4...20mA: 0mA ↔ -6912dec = E500h

Release diagnostic interrupt

Please regard as soon as you release the diagnostic interrupt at run time, the according group diagnostics are just activated during hardware configuration. Otherwise no interrupt can be initialized. More information can be found at "Diagnostics" further down.

CPU-Stop reaction

Here the module reaction at CPU-STOP can be set. You have the following possibilities:

- OCV: output de-energized (according to the module)
- KLV: Keep last value
- SV: Substitute a value

Get mode output type output range

Depending on the module at the register "Outputs" at *Output* the type voltage, current output or deactivated and the according range can be selected. As shown in the following illustration the parameter *mode* is made up of the coding of the output range and type during run time parameterization each channel.

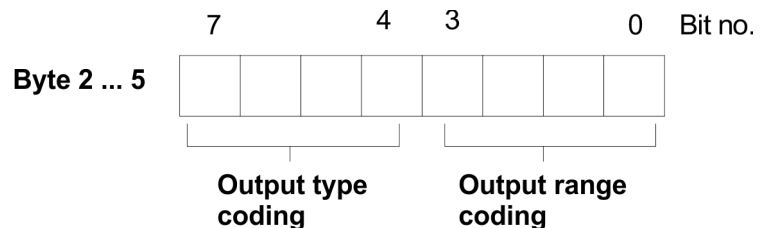

The corresponding codes can be found in the following table. Within the output types the output ranges are specified, for which a binary output range code is to be specified in each case.

Output type voltage output (Output type coding: 0001b)

Output range	Range / Unit	Output range coding
0...10V	11.758V = End overdrive region (32511) 0...10V = Nominal region (0...27648)	1000b
1...5V	5.879V = End overdrive region (32511) 1...5V = Nominal region (0...27648) 0V = End underdrive region (-6912)	0111b
+/- 10V	11.758V = End overdrive region (32511) -10...10V = Nominal range (-27648...27648) -11.759V = End underdrive region (-32512)	1001b

Output type current output (Output type coding: 0010b)

Output range	Range / Unit	Output range coding
0...20mA	23.515 mA = End overdrive region (32511) 0...20mA = Nominal range (0...27648)	0010b
4...20mA	22.810mA = End overdrive region (32511) 4...20mA = Nominal range (0...27648) 0mA = End underdrive region (-6912)	0011b
+/- 20mA	23.515mA = End overdrive region (32511) -20...20mA = Nominal range (-27648...27648) -23.515mA = End underdrive region (-32512)	0100b

4.5 Diagnostics

Overview

As soon as an error occurs and activated *Group diagnostics*, it is record in the diagnostic area that can be evaluated by means of the user application. If the diagnostic interrupt is released at the parameterization, incoming and outgoing error events are signaled by interrupts and monitored on the according analog output module via LED. At a diagnostic interrupt the CPU interrupts its user application and works on the OB 82. For more detailed diagnostic information you may call the SFC 51 res. SFC 59 in the OB 82. The diagnostic data is consistent until you leave the OB 82.

Starting the diagnosis

When an error occurs and after error correction, the diagnosis is started. Via the parameterization you fix the diagnosis behavior at error:

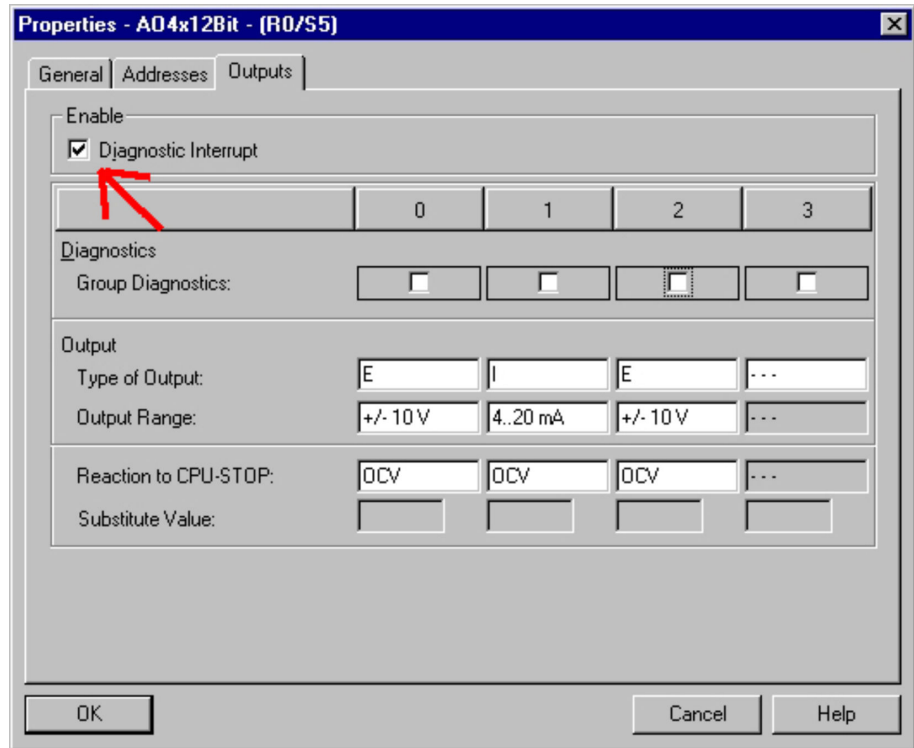

A diagnostic interrupt is only transmitted to the CPU, if you have activated the diagnostic interrupt in the parameterization window. The following errors a diagnosis:

- Wire break at current output (only 332-5Hx01)
- Ground short circuit (only 332-5Hx01)
- Operate the front switch (only 332-5HDx0)
- Failure of the external voltage supply
- Project engineering and parameterization error

Diagnostics data

The diagnostics data is stored in the record sets 0 and 1 of the system data area. As soon as you have activated the diagnostic interrupt release of the parameter area (record set 1, byte 0), on error *record set 0* of the diagnostics data is transferred to the superordinated system. For extended diagnosis during run time, you may also evaluate the *Record set 1* via the SFCs 51 and 59.

Evaluate diagnosis

At a diagnostics event the CPU interrupts the user program and branches into OB 82. This OB allows you via according programming to request detailed diagnostic information by means of the SFCs 51 and 59 and react to it. After the working off of the OB 82, the processing of the user application is continued. The diagnostic data are consistent until leaving the OB 82.

Diagnosis record set 0

The *record set 0* has a fixed content. The content of record set 0 may be monitored in plain text in the diagnosis window of the CPU.

Byte	Bit 7 ... Bit 0	Default
0	<ul style="list-style-type: none"> ■ Bit 0: Error in module ■ Bit 1: reserved ■ Bit 2: External error ■ Bit 3: Channel error ■ Bit 4: external voltage supply missing ■ Bit 5, 6: reserved ■ Bit 7: Wrong parameter in module 	00h
1	<ul style="list-style-type: none"> ■ Bit 3 ... 0: Module class <ul style="list-style-type: none"> – 0101 Analog module ■ Bit 4: Channel information present 	15h
2	<ul style="list-style-type: none"> ■ Bit 0, 1: reserved ■ Bit 2: Operating status: <ul style="list-style-type: none"> – 0: RUN – 1: STOP ■ Bit 7 ... 4: reserved 	00h
3	not used	00h

Diagnosis record set 1 The record set 1 contains the 4byte of record set 0 and additionally 8byte module specific diagnostic data. The diagnostic bytes have the following content:

Byte	Bit 7...Bit 0	Default
0 ... 3	Content record set 0 (see page before)	
4	<ul style="list-style-type: none"> ■ Bit 6 ... 0: Channel type: <ul style="list-style-type: none"> – 73h: Analog output ■ Bit 7: More channel types present <ul style="list-style-type: none"> – 0: no – 1: yes 	73h
5	■ Bit 7 ... 0: Number of diagnostic bits, that the module throws per channel	08h
6	■ Bit 7 ... 0: Number of similar channels of a module	04h
7	<ul style="list-style-type: none"> ■ Bit 0: Channel error Channel 0 ■ Bit 1: Channel error Channel 1 ■ Bit 2: Channel error Channel 2 ■ Bit 3: Channel error Channel 3 ■ Bit 7 ... 4: reserved 	00h
	332-5Hx01	332-5HDx0

Byte	Bit 7...Bit 0	Default	
8	Channel specific error: Channel 0 <ul style="list-style-type: none"> ■ Bit 0: Project engineering/Parameterization error ■ Bit 1, 2: reserved ■ Bit 3: Short circuit after M ■ Bit 4: Wire break ■ Bit 7...5: reserved 	Channel specific error: Channel 0 <ul style="list-style-type: none"> ■ Bit 0: Project engineering/Parameterization error ■ Bit 4...1: reserved ■ Bit 5: Front switch <ul style="list-style-type: none"> – 0: Automatic – 1: Hand operation ■ Bit 7...6: reserved 	00h
9	Channel specific error: Channel 1 Content see Channel 0	Channel specific error: Channel 1 Content see Channel 0	00h
...			
11	Channel specific error: Channel 3 Content see Channel 0	Channel specific error: Channel 3 Content see Channel 0	00h
12 ... 15	reserved		

Channel error by switching to manual operation at 332-5HDx0

The switch to manual operation is interpreted as a channel error. The appropriate bit for channel errors in byte 7 of record set 1 is set. An Interrupt_{going} is only possible if all by group diagnostics activated switches are turned to automatic operation.

Error indication via LEDs (only 332-5Hx01)

At activated *group diagnostics* the group error LED (SF) and the according channel error LED are activated by diagnostic requirement of the modules with order no. 332-5Hx01.

Evaluating the diagnosis

At a diagnostic requirement the CPU interrupts the user program and branches into OB 82. This OB allows you via according programming to request detailed diagnostic information by means of the SFCs 51 and 59 and react to it. After the working off of the OB 82, the processing of the user application is continued. The diagnostic data are consistent until leaving the OB 82.

Error cause and remedy

Message	Possible error cause	Remedial
External load voltage missing	Load voltage L+ of the module is missing	Proof connections L+ and M, Proof power supply
Project engineering/Parameterization error	Wrong parameters have been transferred to the module	Proof parameterization
Ground short circuit (only 332-5Hx01)	Output overload	Remove overload
	Short circuit of the output QV after M-	Check load connection for short circuit

332-5HB01 - AO 2/4x12Bit U/I 2-channel

Message	Possible error cause	Remedial
Wire break (only 332-5Hx01)	Line interruption between module and actuator	Check line
	actuator is too high-resistance	Use another actuator type Use lines with more core-cross section
	Channel is not used	Deactivate channel in parameterization
Front switch manual mode (only 332-5HDx0)	Manual intervention by means of the front switch.	switch all by group diagnostics activated switches to <i>automatic operation</i> .

4.6 332-5HB01 - AO 2/4x12Bit U/I 2-channel

Properties

There are 2 analog outputs which functions may be parameterized individually. The module has to be provided with external DC 24V.

- 2 individual parameterizable outputs
- the outputs are parameterizable per channel as
 - voltage output
 - current output
 - deactivated
- usable for actuators with inputs of
 - ±10V
 - 1 ... 5V
 - 0 ... 10V
 - ±20mA
 - 4 ... 20mA
 - 0 ... 20mA
- parameterizable diagnostics and diagnostics interrupt
- isolated between backplane bus and load voltage

Measuring range after Power ON

After Power ON, the module has the following default settings:

- Output range: ±10V for all channels
- Interrupts are deactivated

The module is to be projected as Siemens analog output module **6ES7 332-5HB01-0AB0**.



The deployment of the module at the active backplane bus is not possible!

Structure

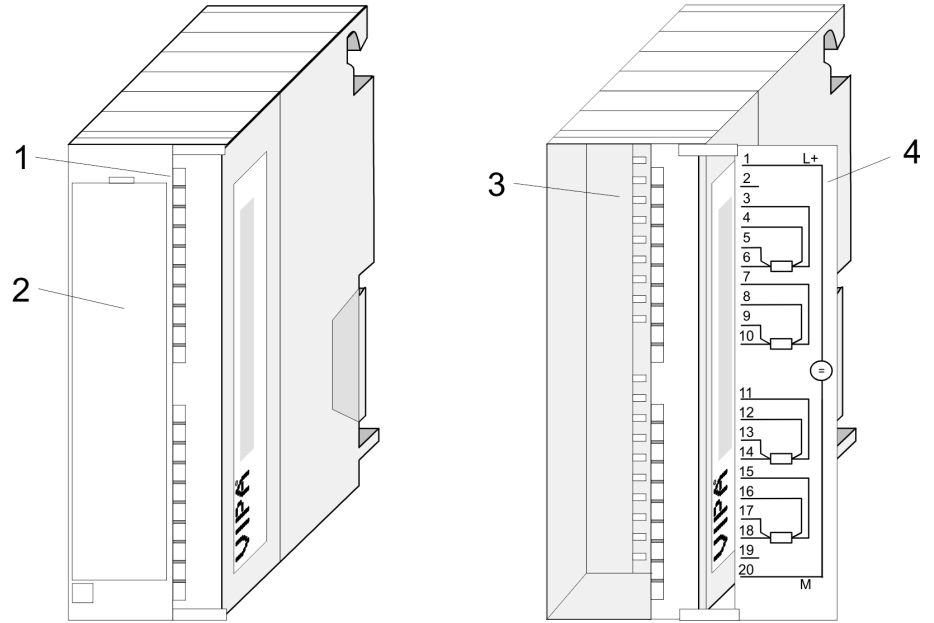

- 1 LEDs
- 2 flap with labeling strip
- 3 contact bar
- 4 flap opened with inner label

Pin assignment/LED

Pin	Circuit diagram		LED	Description	
1	1 L+ DC 24V		SF	LED (red) Sum error, flashes at missing ext. voltage supply	
2	2				
3	3 Q_{I_0} QV_0		Q0		
4	4 CH_0 S_{+0}		F0		
5	5 M_0 M_0		Q1		
6	6 Q_{I_1} QV_1		F1		
7	7 CH_1 S_{+1}				
8	8 M_1 M_1				
9					
10	10				
11	11			Q0 ... Q1	LED (green) the according channel is activated
12	12				
13	13				
14	14				
15	15				
16	16				
17	17 M			F0 ... F1	LED (red) Error channel 0 ... 1
18					
19					
20					



Please regard, that you must not connect the S-Pin at current output!



CAUTION!

Please regard that the modules do not have hardware precautions against wrong parameterization. The setting of the according measuring range is exclusively at the project engineering.

Status monitor via LEDs

LED	Description
SF	Group error: <ul style="list-style-type: none"> ■ On at parameterized group diagnostics, as soon as a diagnostic entry is present. ■ On independently from diagnostics at missing external voltage supply
Q0...Q1	Channel active: On when the according output channel has been activated
F0...F1	Channel error: On together with SF at the according channel with error.

4.6.1 Technical data

Order no.	332-5HB01
Type	SM 332
SPEED-Bus	-
Current consumption/power loss	
Current consumption from backplane bus	100 mA
Power loss	2.5 W
Technical data analog outputs	
Number of outputs	2
Cable length, shielded	-
Rated load voltage	DC 24 V
Reverse polarity protection of rated load voltage	-
Current consumption from load voltage L+ (without load)	70 mA
Voltage output short-circuit protection	✓
Voltage outputs	✓
Min. load resistance (voltage range)	1 kΩ
Max. capacitive load (current range)	1 μF
Max. inductive load (current range)	30 mA
Output voltage ranges	-10 V ... +10 V 0 V ... +10 V +1 V ... +5 V
Operational limit of voltage ranges	+/-0.2% ... +/-0.8%
Basic error limit voltage ranges	+/-0.1% ... +/-0.5%

Order no.	332-5HB01
Destruction limit against external applied voltage	max. 16V (30V / 10s)
Current outputs	✓
Max. in load resistance (current range)	500 Ω
Max. inductive load (current range)	10 mH
Typ. open circuit voltage current output	-
Output current ranges	-20 mA ... +20 mA 0 mA ... +20 mA +4 mA ... +20 mA
Operational limit of current ranges	+/-0.3% ... +/-0.8%
Basic error limit current ranges	+/-0.2% ... +/-0.5%
Destruction limit against external applied voltage	max. 16V (30V / 10s)
Settling time for ohmic load	0.2 ms
Settling time for capacitive load	1 ms
Settling time for inductive load	1 ms
Resolution in bit	13
Conversion time	0.5 ms all channels
Substitute value can be applied	yes
Output data size	4 Byte
Status information, alarms, diagnostics	
Status display	green LED per channel
Interrupts	yes
Process alarm	no
Diagnostic interrupt	yes, parameterizable
Diagnostic functions	yes
Diagnostics information read-out	possible
Supply voltage display	none
Group error display	red SF LED
Channel error display	red LED per channel
Isolation	
Between channels	-
Between channels of groups to	-
Between channels and backplane bus	✓
Between channels and power supply	✓

Order no.	332-5HB01
Max. potential difference between circuits	-
Max. potential difference between inputs (U _{cm})	-
Max. potential difference between Mana and Mintern (U _{iso})	DC 75 V/ AC 50 V
Max. potential difference between inputs and Mana (U _{cm})	-
Max. potential difference between inputs and Mintern (U _{iso})	-
Max. potential difference between Mintern and outputs	-
Insulation tested with	DC 500 V
Datasizes	
Input bytes	0
Output bytes	4
Parameter bytes	21
Diagnostic bytes	16
Housing	
Material	PPE
Mounting	Rail System 300
Mechanical data	
Dimensions (WxHxD)	40 mm x 125 mm x 120 mm
Weight	230 g
Environmental conditions	
Operating temperature	0 °C to 60 °C
Storage temperature	-25 °C to 70 °C
Certifications	
UL certification	yes
KC certification	yes

The error limits for voltage output were determined with a load R=1GΩ.

The error limits for current output were determined with a load R=10Ω.

Additional Technical data

Order number	332-5HB01
Analog value generation	
Resolution (incl. sign)	

332-5HD01 - AO 2/4x12Bit U/I 4-channel

Order number	332-5HB01
±10V; ±20mA	12Bit + sign
1 ... 5V; 4 ... 20mA	11Bit
0 ... 10V; 0 ... 20mA	12Bit
Cycle time (all channels)	0.5ms
Suppression of interference, Limits of Error	
Crosstalk between outputs	> 40dB
Temperature error (with reference to the output range)	±0.01%/K
Linearity error (with reference to the output range)	±0.1%
Repeatability (in steady state at 25°C, referred to output range)	±0.05%
Output ripple; Range 0 to 50kHz (referred to output range)	±0.05%

4.7 332-5HD01 - AO 2/4x12Bit U/I 4-channel

Properties

There are 4 analog outputs which functions may be parameterized individually. The module has to be provided with external DC 24V.

- 4 individual parameterizable outputs
- the outputs are parameterizable per channel as
 - voltage output
 - current output
 - deactivated
- usable for actuators with inputs of
 - ±10V
 - 1 ... 5V
 - 0 ... 10V
 - ±20mA
 - 4 ... 20mA
 - 0 ... 20mA
- parameterizable diagnostics and diagnostics interrupt
- isolated between backplane bus and load voltage

Measuring range after Power ON

After Power ON, the module has the following default settings:

- Output range: ±10V for all channels
- Interrupts are deactivated

The module is to be projected as Siemens analog output module
6ES7 332-5HD01-0AB0



The deployment of the module at the active backplane bus is not possible!

Structure

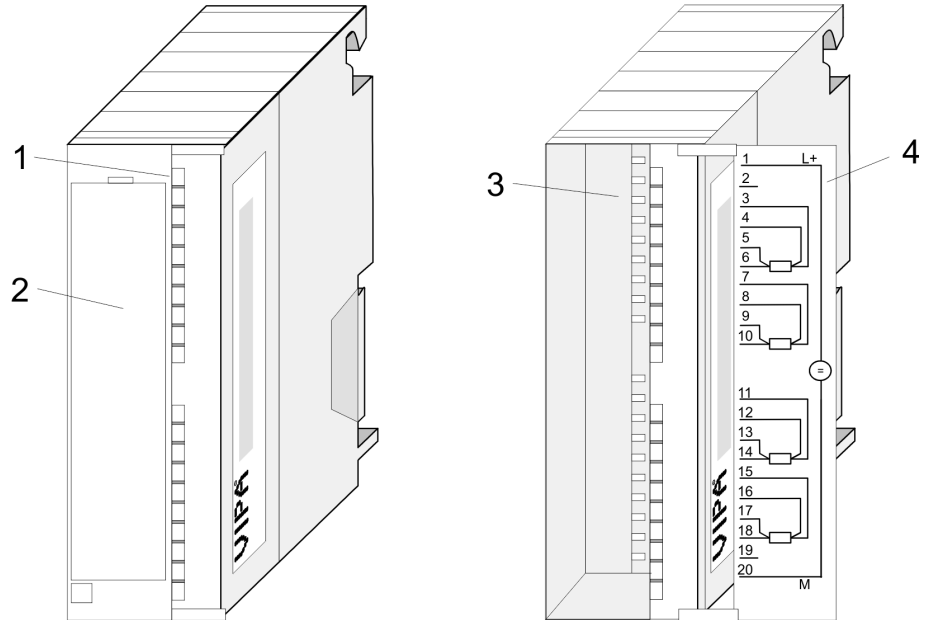

- 1 LEDs
- 2 flap with labeling strip
- 3 contact bar
- 4 flap opened with inner label

Pin assignment/LED

Pin	Circuit diagram		LED	Description	
1	1 L+ DC 24V		SF	LED (red) Sum error, flashes at missing external voltage supply	
2	2				
3	3 Q_{I_0} QV_0		Q0	Q0 ... Q1	LED (green) the according channel is activated
4	4 S_{+0}		F0		
5	5 S_{-0}		Q1		
6	6 M_0 M_0		F1		
7	7 Q_{I_1} QV_1		SM332	F0 ... F3	LED (red) Error channel 0 ... 3
8	8 S_{+1}				
9	9 S_{-1}				
10	10 M_1 M_1				
11	11 Q_{I_2} QV_2		Q2	Q0 ... Q1	LED (green) the according channel is activated
12	12 S_{+2}		F2		
13	13 S_{-2}		Q3		
14	14 M_2 M_2		F3		
15	15 Q_{I_3} QV_3		SM332	F0 ... F3	LED (red) Error channel 0 ... 3
16	16 S_{+3}				
17	17 S_{-3}				
18	18 M_3 M_3				
19	19				
20	20 M				



Please regard, that you must not connect the S-Pin at current output!



CAUTION!

Please regard that the modules do not have hardware precautions against wrong parameterization. The setting of the according measuring range is exclusively at the project engineering.

Status monitor via LEDs

LED	Description
SF	Group error: <ul style="list-style-type: none"> ■ On at parameterized group diagnostics, as soon as a diagnostic entry is present. ■ On independently from diagnostics at missing external voltage supply.
Q0...Q3	Channel active: On when the according output channel has been activated.
F0...F3	Channel error: On together with SF at the according channel with error.

4.7.1 Technical data

Order no.	332-5HD01
Type	SM 332
SPEED-Bus	-
Current consumption/power loss	
Current consumption from backplane bus	125 mA
Power loss	3.5 W
Technical data analog outputs	
Number of outputs	4
Cable length, shielded	-
Rated load voltage	DC 24 V
Reverse polarity protection of rated load voltage	-
Current consumption from load voltage L+ (without load)	115 mA
Voltage output short-circuit protection	✓
Voltage outputs	✓
Min. load resistance (voltage range)	1 kΩ
Max. capacitive load (current range)	1 μF
Max. inductive load (current range)	30 mA
Output voltage ranges	-10 V ... +10 V 0 V ... +10 V +1 V ... +5 V
Operational limit of voltage ranges	+/-0.2% ... +/-0.8%
Basic error limit voltage ranges	+/-0.1% ... +/-0.5%

Order no.	332-5HD01
Destruction limit against external applied voltage	max. 16V (30V / 10s)
Current outputs	✓
Max. in load resistance (current range)	500 Ω
Max. inductive load (current range)	10 mH
Typ. open circuit voltage current output	-
Output current ranges	-20 mA ... +20 mA 0 mA ... +20 mA +4 mA ... +20 mA
Operational limit of current ranges	+/-0.3% ... +/-0.8%
Basic error limit current ranges	+/-0.2% ... +/-0.5%
Destruction limit against external applied voltage	max. 16V (30V / 10s)
Settling time for ohmic load	0.2 ms
Settling time for capacitive load	1 ms
Settling time for inductive load	1 ms
Resolution in bit	13
Conversion time	1 ms all channels
Substitute value can be applied	yes
Output data size	8 Byte
Status information, alarms, diagnostics	
Status display	green LED per channel
Interrupts	yes
Process alarm	no
Diagnostic interrupt	yes, parameterizable
Diagnostic functions	yes
Diagnostics information read-out	possible
Supply voltage display	none
Group error display	red SF LED
Channel error display	red LED per channel
Isolation	
Between channels	-
Between channels of groups to	-
Between channels and backplane bus	✓
Between channels and power supply	✓

Order no.	332-5HD01
Max. potential difference between circuits	-
Max. potential difference between inputs (U _{cm})	-
Max. potential difference between Mana and Mintern (U _{iso})	DC 75 V/ AC 50 V
Max. potential difference between inputs and Mana (U _{cm})	-
Max. potential difference between inputs and Mintern (U _{iso})	-
Max. potential difference between Mintern and outputs	-
Insulation tested with	DC 500 V
Datasizes	
Input bytes	0
Output bytes	8
Parameter bytes	21
Diagnostic bytes	16
Housing	
Material	PPE
Mounting	Rail System 300
Mechanical data	
Dimensions (WxHxD)	40 mm x 125 mm x 120 mm
Weight	230 g
Environmental conditions	
Operating temperature	0 °C to 60 °C
Storage temperature	-25 °C to 70 °C
Certifications	
UL certification	yes
KC certification	yes

The error limits for voltage output were determined with a load R=1GΩ.

The error limits for current output were determined with a load R=10Ω.

Additional Technical data

Order number	332-5HD01
Analog value generation	
Resolution (incl. sign)	

Order number	332-5HD01
±10V; ±20mA	12Bit + sign
1 ... 5V; 4 ... 20mA	11Bit
0 ... 10V; 0 ... 20mA	12Bit
Cycle time (all channels)	1ms
Suppression of interference, Limits of Error	
Crosstalk between outputs	> 40dB
Temperature error (with reference to the output range)	±0.01%/K
Linearity error (with reference to the output range)	±0.1%
Repeatability (in steady state at 25°C, referred to output range)	±0.05%
Output ripple; Range 0 to 50kHz (referred to output range)	±0.05%

4.8 332-5HD50 - AO 4x12Bit I for manual operation

Properties

For each channel there is a 2pole switch with associated potentiometer on the front side of the two modules. An analog value may be preset by the potentiometer, which is issued at the corresponding channel by switching to manual operation. The module has to be provided with external DC 24V.

- 4 individual parameterizable outputs
- the outputs are parameterizable per channel as:
 - Current output 4...20mA
 - deactivated
- usable for actuators with an input of 4 ... 20mA
- parameterizable diagnostics and diagnostics interrupt
- 1 switch each channel (Automatic-/Manual operation)
- 1 potentiometer each channel
- isolated between backplane bus and load voltage
- status LED for power supply

Measuring range after PowerON

After PowerON the interrupts are deactivated.

The modules have are to be configured as **6ES7 332-5HD01** from Siemens. ↪ *Chapter 4.4 'Parameterization - Basics' on page 82*

Structure

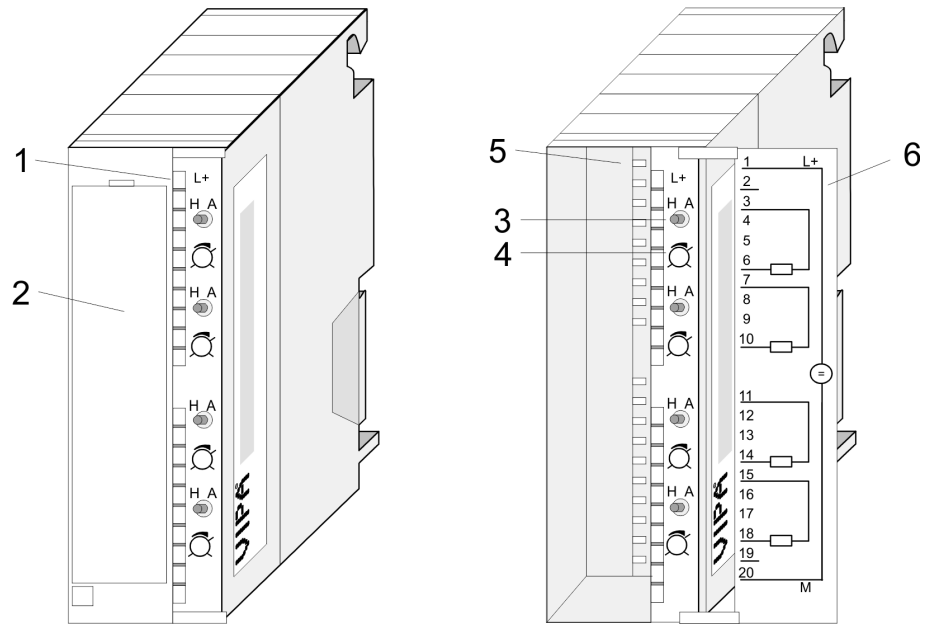

- 1 LED L+
- 2 flap with labeling strip
- 3 switch: H/A Manual-/Automatic operation
- 4 potentiometer
- 5 contact bar
- 6 flap opened with inner label

Pin assignment/LED

Pin	Circuit diagram		LED	Description
1	1 L+ DC 24V		L+	LED (green) supply voltage is on
2	2			
3	3 Q ₀			
4	4			
5	5			
6	6 M ₀			
7	7 Q ₁			
8	8			
9	9			
10	10 M ₁			
11	11 Q ₂			
12	12			
13	13			
14	14 M ₂			
15	15 Q ₃			
16	16			
17	17			
18	18 M ₃			
19	19			
20	20			

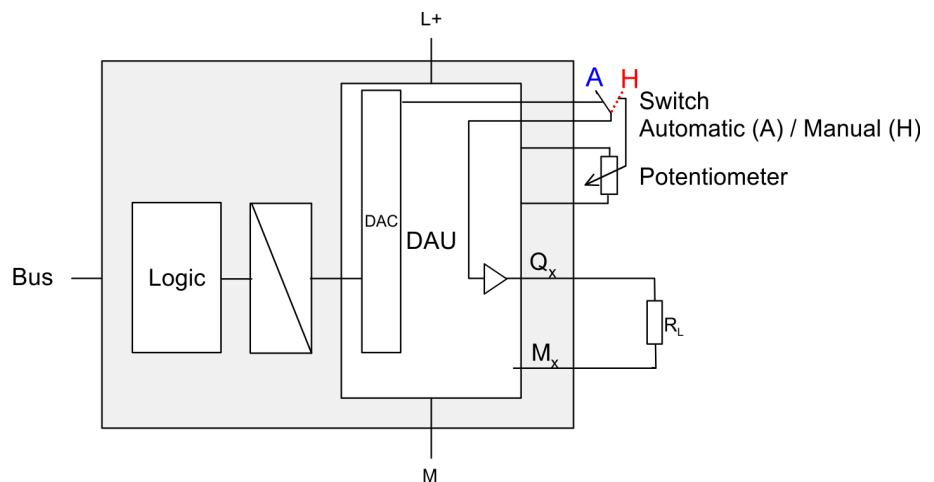

Schematic diagram



4.8.1 Manual operation

Manual operation

For each channel there is a 2pole switch with associated potentiometer on the front side. The operating mode automatic or manual may be toggled by the switch. *At manual operation* the module issues the value at the according channel adjusted by the potentiometer. Depending on the switch position there is the following action:

Front switch	Description
Manual operation 	Issues at the output channel the value adjusted by the potentiometer. Note! As long as the module is supplied with DC 24V, in manual operation, independently of the mode of operation of the CPU, the by potentiometer adjusted value is issued at the output channel.
Automatic operation 	The channel operates as a "normal" analog output channel and can be controlled by PLC program.

Potentiometer



For each channel there is a potentiometer on the front side. Here you can preset an analog value from min. up to max. of the nominal range. If the potentiometer is turned in the clockwise direction beyond the max. position, then the overdrive region is reached. Hardware conditionally an exact marking of the ranges is not possible. As soon as you turn the switch into position "H" (manual operation), the value adjusted by the potentiometer is issued at the according output channel. Depending on the module there are the following ranges:

Order no.	Nominal range (min. ... max.)	max. overdrive region
332-5HD50	4...20mA	ca. 24mA
332-5HD60	0...10V	ca. 12V

Channel error by switching to manual operation

The switch to *manual operation* is interpreted as a channel error. The appropriate bit for channel errors in byte 7 of the diagnostics record set 1 is set. An Interrupt_{going} is only possible if all by group diagnostics activated switches are turned to automatic operation. ↪ Chapter 4.5 'Diagnostics' on page 86

**DANGER!**

With the modules you can cause a jump in the analog value by means of the switch, independently of the CPU operation mode, as long as the module is power supplied. This could lead to material damage or personal injury! Please regard also that disconnecting res. connecting during operation, the so-called "Hot Swapping", is not possible!

4.8.2 Technical data

Order number	332-5HD50
Type	SM 332
SPEED-Bus	-
Current consumption/power loss	
Current consumption from backplane bus	80 mA
Power loss	3.5 W
Technical data analog outputs	
Number of outputs	4
Cable length, shielded	-
Rated load voltage	DC 24 V
Current consumption from load voltage L+ (without load)	130 mA
Voltage output short-circuit protection	-
Voltage outputs	-
Min. load resistance (voltage range)	-
Max. capacitive load (current range)	-
Output voltage ranges	-
Operational limit of voltage ranges	-
Basic error limit voltage ranges	-
Current outputs	✓
Max. in load resistance (current range)	500 Ω
Max. inductive load (current range)	10 mH
Output current ranges	+4 mA ... +20 mA
Operational limit of current ranges	+/-0.4%
Basic error limit current ranges	+/-0.2%
Settling time for ohmic load	0.5 ms

Order number	332-5HD50
Settling time for capacitive load	-
Settling time for inductive load	0.5 ms
Resolution in bit	12
Conversion time	0.5 ms all channels
Substitute value can be applied	yes
Output data size	8 Byte
Status information, alarms, diagnostics	
Status display	none
Interrupts	-
Process alarm	no
Diagnostic interrupt	yes, parameterizable
Diagnostic functions	yes
Diagnostics information read-out	possible
Supply voltage display	green LED
Group error display	none
Channel error display	none
Isolation	
Between channels	-
Between channels of groups to	-
Between channels and backplane bus	✓
Between channels and power supply	✓
Max. potential difference between circuits	-
Max. potential difference between inputs (U _{cm})	-
Max. potential difference between Mana and Mintern (U _{iso})	DC 75 V/ AC 50 V
Max. potential difference between inputs and Mana (U _{cm})	-
Max. potential difference between inputs and Mintern (U _{iso})	-
Max. potential difference between Mintern and outputs	-
Insulation tested with	DC 500 V
Datasizes	
Input bytes	0
Output bytes	8

Order number	332-5HD50
Parameter bytes	21
Diagnostic bytes	16
Housing	
Material	PPE
Mounting	Rail System 300
Mechanical data	
Dimensions (WxHxD)	40 x 125 x 120 mm
Weight	250 g
Environmental conditions	
Operating temperature	0 °C to 60 °C
Storage temperature	-25 °C to 70 °C
Certifications	
UL certification	yes

The error limits were determined with a load $R=10\Omega$.

Additional Technical data

Order number	332-5HD50
Suppression of interference, Limits of error	
Crosstalk between the outputs	> 40dB
Temperature error (with reference to the output range)	$\pm 0.01\%/K$
Linearity error (with reference to the input range)	$\pm 0.15\%$
Repeatability (in steady state at 25°C, referred to output range)	$\pm 0.05\%$
Output ripple; range 0 to 50kHz (referred to output range)	$\pm 0.05\%$
Data for selecting an actuator	
Current outputs	
- No-load voltage	15V
Destruction limit against voltage/currents applied from outside	
- Voltage at outputs to M_{ANA}	max. 15V
- Current	max. 25mA
Connecting actuators	
- 2-conductor connection	possible

4.9 332-5HD60 - AO 4x12Bit U for manual operation

Properties

For each channel there is a 2pole switch with associated potentiometer on the front side of the two modules. An analog value may be preset by the potentiometer, which is issued at the corresponding channel by switching to manual operation. The module has to be provided with external DC 24V.

- 4 individual parameterizable outputs
- the outputs are parameterizable per channel as:
 - voltage output 0...10V
 - deactivated
- usable for actuators with an input of 0 ... 10V
- parameterizable diagnostics and diagnostics interrupt
- 1 switch each channel (Automatic-/Manual operation)
- 1 potentiometer each channel
- isolated between backplane bus and load voltage
- status LED for power supply

Measuring range after PowerON

After PowerON the interrupts are deactivated.

The module has to be configured as **6ES7 332-5HD01** from Siemens.
 ↪ Chapter 4.4 'Parameterization - Basics' on page 82

Structure

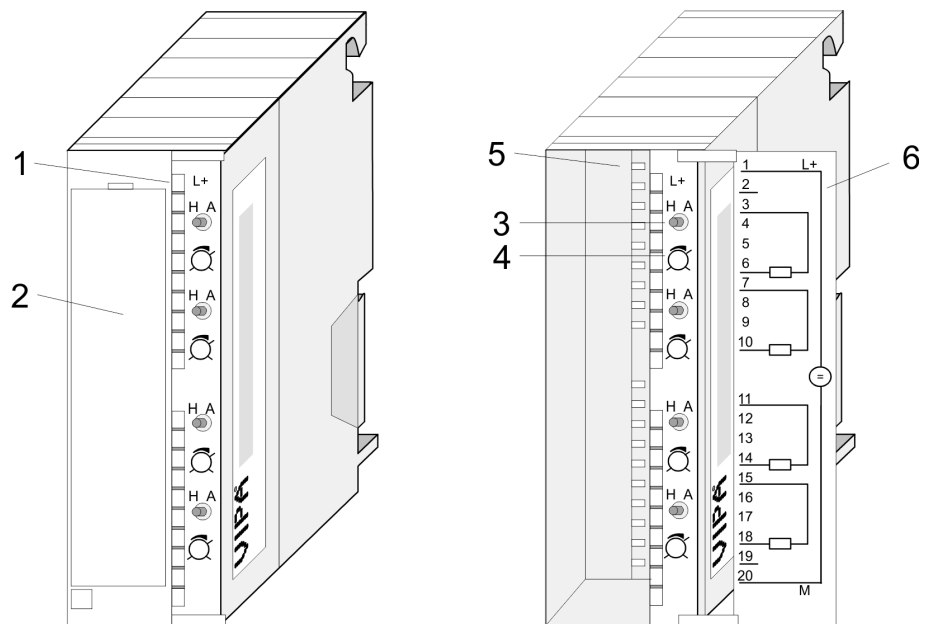

- 1 LED L+
- 2 flap with labeling strip
- 3 switch: H/A Manual/Automatic mode
- 4 potentiometer
- 5 contact bar
- 6 flap opened with inner label

Pin assignment/LED

Pin	Circuit diagram		LED	Description
1	1 L+ DC 24V		L+	LED (green) supply voltage is on
2	2			
3	3 Q ₀			
4	4			
5	5			
6	6 M ₀			
7	7 Q ₁			
8	8			
9	9			
10	10 M ₁			
11	11 Q ₂			
12	12			
13	13			
14	14 M ₂			
15	15 Q ₃			
16	16			
17	17 M			
18				
19				
20				

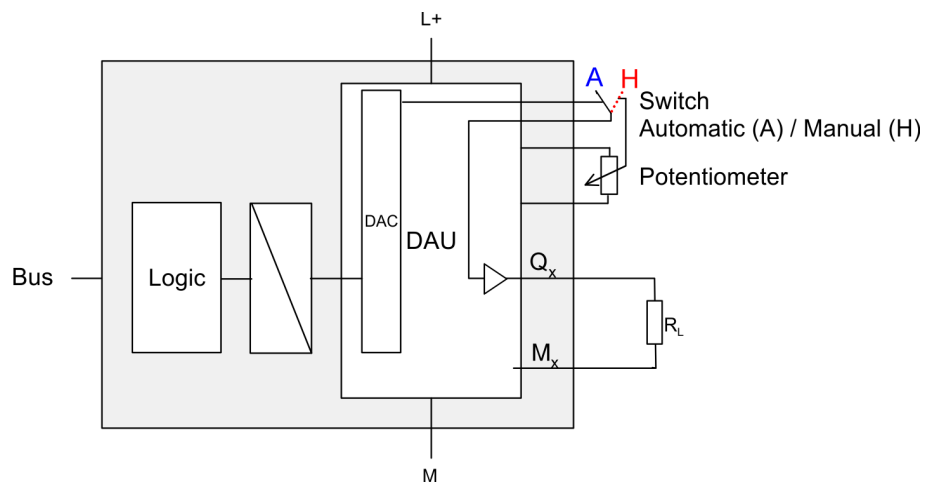

Schematic diagram



4.9.1 Manual operation

Manual operation

For each channel there is a 2pole switch with associated potentiometer on the front side. The operating mode automatic or manual may be toggled by the switch. At *manual operation* the module issues the value at the according channel adjusted by the potentiometer. Depending on the switch position there is the following action:

Front switch	Description
<p>Manual operation</p> 	<p>Issues at the output channel the value adjusted by the potentiometer.</p> <p>Note! As long as the module is supplied with DC 24V, in manual operation, independently of the mode of operation of the CPU, the by potentiometer adjusted value is issued at the output channel.</p>
<p>Automatic operation</p> 	<p>The channel operates as a "normal" analog output channel and can be controlled by PLC program.</p>

Potentiometer



For each channel there is a potentiometer on the front side. Here you can preset an analog value from min. up to max. of the nominal range. If the potentiometer is turned in the clockwise direction beyond the *max.* position, then the overdrive region is reached. Hardware conditionally an exact marking of the ranges is not possible. As soon as you turn the switch into position "H" (manual operation), the value adjusted by the potentiometer is issued at the according output channel. Depending on the module there are the following ranges:

Order no.	Nominal range (min. ... max.)	max. overdrive region
332-5HD50	4...20mA	ca. 24mA
332-5HD60	0...10V	ca. 12V

Channel error by switching to manual operation

The switch to manual operation is interpreted as a channel error. The appropriate bit for channel errors in byte 7 of the diagnostics record set 1 is set. An Interrupt_{going} is only possible if all by group diagnostics activated switches are turned to automatic operation. ↪ *Chapter 4.5 'Diagnostics' on page 86*

**DANGER!**

With the modules you can cause a jump in the analog value by means of the switch, independently of the CPU operation mode, as long as the module is power supplied. This could lead to material damage or personal injury! Please regard also that disconnecting res. connecting during operation, the so-called "Hot Swapping", is not possible!

4.9.2 Technical data

Order number	332-5HD60
Type	SM 332
SPEED-Bus	-
Current consumption/power loss	
Current consumption from backplane bus	80 mA
Power loss	3.5 W
Technical data analog outputs	
Number of outputs	4
Cable length, shielded	-
Rated load voltage	DC 24 V
Current consumption from load voltage L+ (without load)	130 mA
Voltage output short-circuit protection	✓
Voltage outputs	✓
Min. load resistance (voltage range)	1 kΩ
Max. capacitive load (current range)	1 μF
Output voltage ranges	0 V ... +10 V
Operational limit of voltage ranges	+/-0.4%
Basic error limit voltage ranges	+/-0.2%
Current outputs	-
Max. in load resistance (current range)	-
Max. inductive load (current range)	-
Output current ranges	-
Operational limit of current ranges	-
Basic error limit current ranges	-
Settling time for ohmic load	1.5 ms
Settling time for capacitive load	1.5 ms

Order number	332-5HD60
Settling time for inductive load	-
Resolution in bit	12
Conversion time	0.5 ms all channels
Substitute value can be applied	yes
Output data size	8 Byte
Status information, alarms, diagnostics	
Status display	none
Interrupts	-
Process alarm	no
Diagnostic interrupt	yes, parameterizable
Diagnostic functions	yes
Diagnostics information read-out	possible
Supply voltage display	green LED
Group error display	none
Channel error display	none
Isolation	
Between channels	-
Between channels of groups to	-
Between channels and backplane bus	✓
Between channels and power supply	✓
Max. potential difference between circuits	-
Max. potential difference between inputs (Ucm)	-
Max. potential difference between Mana and Mintern (Uiso)	DC 75 V/ AC 50 V
Max. potential difference between inputs and Mana (Ucm)	-
Max. potential difference between inputs and Mintern (Uiso)	-
Max. potential difference between Mintern and outputs	-
Insulation tested with	DC 500 V
Datasizes	
Input bytes	0
Output bytes	8
Parameter bytes	21
Diagnostic bytes	16
Housing	

Order number	332-5HD60
Material	PPE
Mounting	Rail System 300
Mechanical data	
Dimensions (WxHxD)	40 x 125 x 120 mm
Weight	250 g
Environmental conditions	
Operating temperature	0 °C to 60 °C
Storage temperature	-25 °C to 70 °C
Certifications	
UL certification	yes

The error limits were determined with a load $R=1G\Omega$.

Additional Technical data

Order number	332-5HD60
Suppression of interference, Limits of error	
Crosstalk between the outputs	> 40dB
Temperature error (with reference to the output range)	$\pm 0.01\%/K$
Linearity error (with reference to the input range)	$\pm 0.15\%$
Repeatability (in steady state at 25°C, referred to output range)	$\pm 0.05\%$
Output ripple; range 0 to 50kHz (referred to output range)	$\pm 0.05\%$
Data for selecting an actuator	
Voltage outputs	
- Short-circuit protection	yes
- Short-circuit current	25mA
Destruction limit against voltage/currents applied from outside	
- Voltage at outputs to M_{ANA}	max. 15V
- Current	max. 30mA
Connecting actuators	
- conductor connection	possible

5 Analog I/O Modules

5.1 General

Cables for analog signals

For analog signals you should use isolated cables to reduce interference. The cable screening should be grounded at both ends. If there are differences in the potential between the cable ends, there may occur a potential compensating current that could disturb the analog signals. In this case you should ground the cable screening only at one end.



Please take always care of the correct polarity when connecting! Please install short circuits at non-used inputs by connecting the positive contact with the channel ground. Please leave the output pins of not used channels disconnected and configure the output type of the channel to "deactivated". In this way the cycle time of the module gets shorter.

Parameterization

The module may be configured by means of a hardware configuration or rather during run time by SFCs.

After PowerON, the module has the following default settings:

- Input range: Pt100 Climate (RTD-4L)
- Output range: voltage 0 ... 10V

5.2 Analog value representation

General

As soon as a measuring value exceeds the overdrive res. underdrive range, the following value is returned:

Measuring value > Overdrive range: 32767 (7FFFh)

Measuring value < Underdrive range: -32768 (8000h)

At parameterization error or de-activated analog part the measuring value 32767 (7FFFh) is returned. When leaving the defined range during analog output 0V is issued. In the following all measuring ranges are specified, which are supported by the analog part. With the formulas it may be converted between measuring and analog value.

Numeric notation in Siemens S7 format

The analog values are represented in two's complement format.

		Analog value															
		High byte							Low byte								
Bit number		15	14	13	12	11	10	9	8	7	6	5	4	3	2	1	0
Resolution	SG	Analog value (word)															
12bit+sign	SG	Relevant output value											X	X	X		
*) The least significant irrelevant bits of the output value are marked by "X".																	

Sign bit (SG)

The algebraic sign bit is represented by Bit 15. Here it is essential:

- Bit 15 = "0" → positive value
- Bit 15 = "1" → negative value

Voltage measuring range 0 ... 10V

Formulas for the conversion:

$$D=27648 \cdot \frac{U}{10}, \quad U=D \cdot \frac{10}{27648}$$

U: voltage, D: decimal value

0...10V	dec.	hex.	Range
> 11.759	32767	7FFFh	Overflow
11.759V	32511	7EFFh	Overdrive range
...	
10V	27648	6C00h	
...	Nominal range
0V	0	0	
Negative values not possible			

Resistance measurement R-4L (0 ... 10kΩ)

Formulas for the conversion:

$$D=27648 \cdot \frac{R}{10000}, \quad R=D \cdot \frac{10000}{27648}$$

R: resistance value, D: decimal value

10kΩ	dec.	hex.	Range
11.852kΩ	32767	7FFFh	Overflow
	32512	7F00h	Overdrive range
11.759kΩ	32511	7EFFh	
.	27649	6C01h	
...	Nominal range
10kΩ	27648	6C00h	
7.5kΩ	20736	5100h	
361.7mΩ	1	0001h	

10kΩ	dec.	hex.	Range
0Ω	0	0000h	
Negative values not possible			Underdrive range

Resistance thermometer (Pt100 Climate)

With Pt 100 the temperature is directly shown with the adjusted unit. Here applies: 1 Digit = 0.01 temperature unit.

Pt100			Pt100			Range
in °C (1digit= 0.01°C)	dec.	hex.	in °F (1digit= 0.01°F)	dec.	hex.	
>155.0	32767	7FFFh	>311.0	32767	7FFFh	Overflow
155.0	15500	3C8Ch	311.0	31100	797Ch	Overdrive range
...	
130.0	13000	32C8h	266.0	26600	67E8h	Nominal range
...	
-120.0	-12000	D120h	-184.0	-18400	B820h	Underdrive range
...	
-145.0	-14500	C75Ch	-229.0	-22900	A68Ch	
< -145.0	-32768	8000h	< -229.0	-32768	8000h	Underflow

**Voltage output range
0 ... 10V**

Formulas for the conversion:

$$D=27648 \cdot \frac{U}{10}, U=D \cdot \frac{10}{27648}$$

U: voltage, D: decimal value

0...10V	dec.	hex.	Range
0V	32767	7FFFh	Overflow
...	
11.76V	32511	7EFFh	Overdrive range
...	
10V	27648	6C00h	Nominal range
...	
0V	0	0	Underdrive range
...	

0...10V	dec.	hex.	Range
0V	-6912	E500h	
...	Underflow
0V	-32768	8000h	

5.3 Parameterization

Overview

There are the following possibilities for parameterization:

- Parameterization by hardware configuration of Siemens SIMATIC manager or with WinPLC7 from VIPA.
- Parameterization during run time by means of SFCs.

5.3.1 Parameterization by hardware configuration

To be compatible to the Siemens SIMATIC manager the following steps are to be accomplished:

1. ▶ Start the hardware configurator from Siemens
2. ▶ Create a new project
3. ▶ Configure your CPU
4. ▶ Link-up your System 300V modules in the plugged-in sequence starting with slot 4.
5. ▶ Configure the analog in/output module as module from Siemens with the order number 6ES7 334-0KE00-0AB0.
 - ⇒ The analog modules may be found at the hardware catalog at *Simatic 300 > SM-300*.
6. ▶ If needed parameterize the CPU respectively the modules. The parameter window appears as soon as you double click on the according module. At this window the according parameter can be changed.
7. ▶ Save your project, switch the CPU to STOP and transfer your project to the CPU. As soon as the CPU is switched to RUN the parameters are transferred to the connected modules.

Parameters

The following parameters may be adjusted at the analog in/output module:

- Starting address of the data
- Input area (deactivated, integration time, measuring type/range)
- Output area (deactivated, voltage output)

A closer description of the parameters may be found below.

5.3.2 Parameterization during run time by means of SFCs

If the module gets parameters, which are not supported by the module, these parameters are interpreted as wrong parameters and an error is initialized via the measuring value 32767 (7FFFh). At the parameterization, a 14byte long parameter area is set in the record set 1. Deploying the SFCs 55, 56 and 57, you may alter parameters during run time and transfer them to the module.

Parameter record set 1

Byte	Bit 7 ... Bit 0
0	Bit 7 ... 0: not relevant
1	Integration time ■ Bit 1, 0: Channel 0 ■ Bit 3, 2: Channel 1 ■ Bit 5, 4: Channel 2 ■ Bit 7, 6: Channel 3
2	Measuring channel 0 ■ Bit 3 ... 0: Measuring range ■ Bit 7 ... 4: Measuring type
3	Measuring channel 1 ■ Bit 3 ... 0: Measuring range ■ Bit 7 ... 4: Measuring type
4	Measuring channel 2 ■ Bit 3 ... 0: Measuring range ■ Bit 7 ... 4: Measuring type
5	Measuring channel 3 ■ Bit 3 ... 0: Measuring range ■ Bit 7 ... 4: Measuring type
6	Output channel 0 ■ Bit 3 ... 0: Output range ■ Bit 7 ... 4: Output type
7	Output channel 1 ■ Bit 3 ... 0: Output range ■ Bit 7 ... 4: Output type
8 ... 13	not relevant

01: 16.6ms
10: 20ms

- Measuring range: Bit 3...0
 - 0000: deactivated
 - 1000: 0 ... 10V
 - 1001: 10kΩ
 - 0000: Pt100 Climate
- Measuring type: Bit 7...4
 - 0000: deactivated
 - 0001: Voltage
 - 0100: Resistance R-4L
 - 1000: Thermometer RTD-4L

- Output range: Bit 3 ... 0
 - 0000: deactivated
 - 1000: 0 ... 10V
- Output type: Bit 7...4
 - 0000: deactivated
 - 0001: Voltage

Voltage measuring via channel 2 and 3

Please regard voltage measurement is only possible by channel 2 and 3.

5.4 334-0KE00 - AI 4/AO 2x12Bit

Properties

There are up to 4 analog inputs and 2 analog outputs, which functions may be parameterized by groups. The module has to be provided with external DC 24V.

- 4 inputs in 2 groups (1. group only Pt100)
- 2 outputs in one group
- Measuring type parameterizable per channel
 - voltage
 - resistor
 - temperature
- Type of output parameterizable per channel group
 - voltage
- isolated between backplane bus and load voltage

Measuring range after PowerON

After PowerON, the module has the following default settings:

- Input range: Pt100 Climate (RTD-4L)
- Output range: voltage 0 ... 10V

The module is to be configured as module from Siemens with order number **6ES7 334-0KE00-0AB0**.



The deployment of the module at the active backplane bus is not possible!

Structure

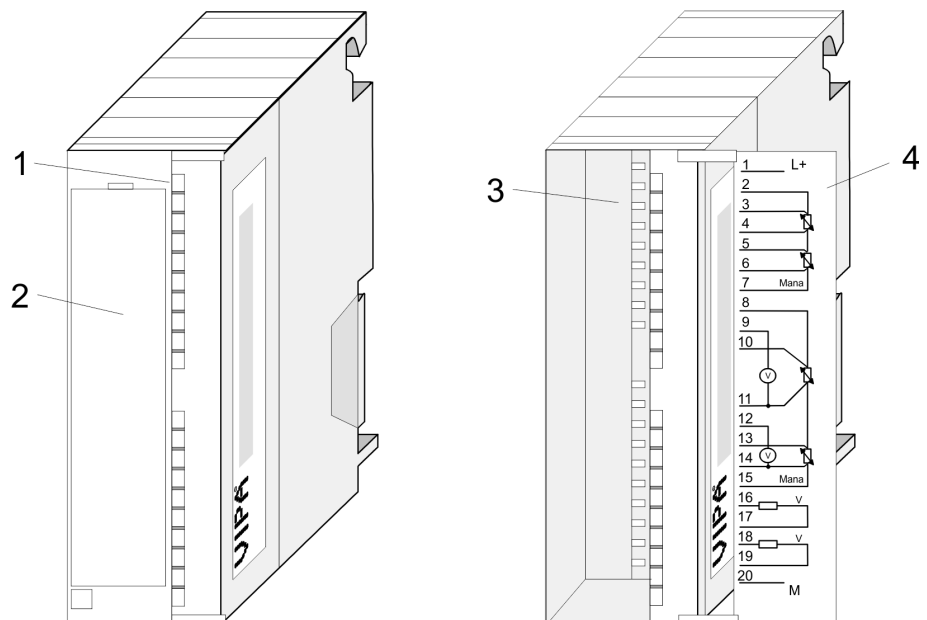

- 1 LED stripe (without function)
- 2 flap with labeling strip
- 3 contact bar
- 4 flap opened with inner label

Pin assignment

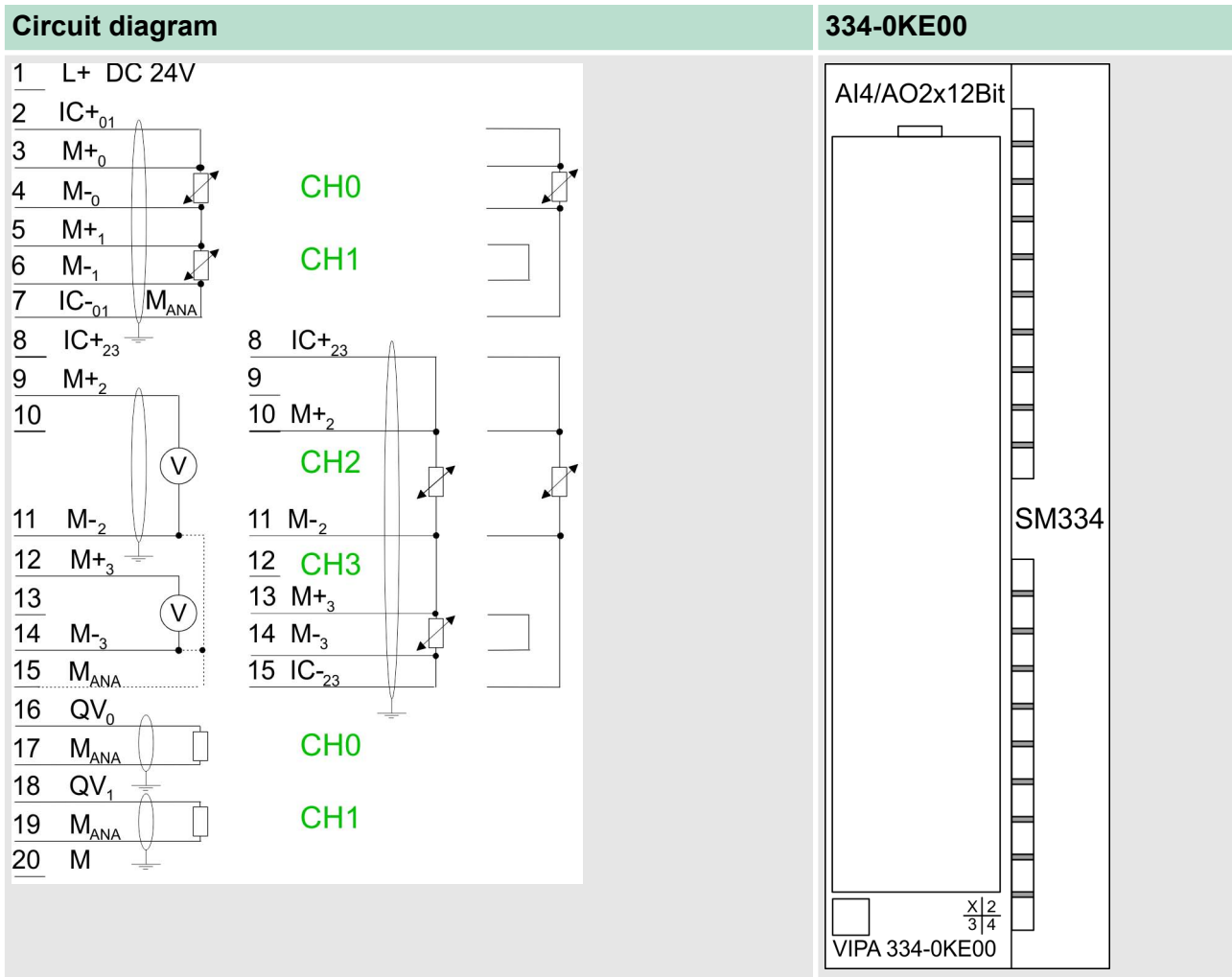

CAUTION! Please regard that the module 334-0KE00 does not have hardware precautions against wrong parameterization. The setting of the according measuring range is exclusively at the project engineering. At the project engineering you should be very careful. Please regard also that disconnecting res. connecting during operation, the so-called "Hot Swapping", is not possible!

5.4.1 Technical data

Order no.	334-0KE00
Type	SM 334
SPEED-Bus	-
Current consumption/power loss	
Current consumption from backplane bus	95 mA

Order no.	334-0KE00
Power loss	2 W
Technical data analog inputs	
Number of inputs	4
Cable length, shielded	100 m
Rated load voltage	DC 24 V
Reverse polarity protection of rated load voltage	-
Current consumption from load voltage L+ (without load)	40 mA
Voltage inputs	✓
Min. input resistance (voltage range)	100 kΩ
Input voltage ranges	0 V ... +10 V
Operational limit of voltage ranges	+/-0.7%
Operational limit of voltage ranges with SFU	-
Basic error limit voltage ranges	+/-0.5%
Basic error limit voltage ranges with SFU	-
Destruction limit voltage	max. 30V
Current inputs	-
Max. input resistance (current range)	-
Input current ranges	-
Operational limit of current ranges	-
Operational limit of current ranges with SFU	-
Basic error limit current ranges	-
Radical error limit current ranges with SFU	-
Destruction limit current inputs (electrical current)	-
Destruction limit current inputs (voltage)	-
Resistance inputs	✓
Resistance ranges	10000 Ohm
Operational limit of resistor ranges	+/-3.5%
Operational limit of resistor ranges with SFU	-
Basic error limit	+/-2.8%
Basic error limit with SFU	-
Destruction limit resistance inputs	max. 25V
Resistance thermometer inputs	✓

Order no.	334-0KE00
Resistance thermometer ranges	Pt100
Operational limit of resistance thermometer ranges	+/-1.0%
Operational limit of resistance thermometer ranges with SFU	-
Basic error limit thermoresistor ranges	+/-0.8%
Basic error limit thermoresistor ranges with SFU	-
Destruction limit resistance thermometer inputs	max. 25V
Thermocouple inputs	-
Thermocouple ranges	-
Operational limit of thermocouple ranges	-
Operational limit of thermocouple ranges with SFU	-
Basic error limit thermoelement ranges	-
Basic error limit thermoelement ranges with SFU	-
Destruction limit thermocouple inputs	-
Programmable temperature compensation	-
External temperature compensation	-
Internal temperature compensation	-
Temperature error internal compensation	-
Technical unit of temperature measurement	°C
Resolution in bit	12
Measurement principle	Sigma-Delta
Basic conversion time	350 ms
Noise suppression for frequency	50 Hz/60 Hz
Initial data size	8 Byte
Technical data analog outputs	
Number of outputs	2
Cable length, shielded	100 m
Rated load voltage	DC 24 V
Reverse polarity protection of rated load voltage	✓
Current consumption from load voltage L+ (without load)	40 mA
Voltage output short-circuit protection	✓

Order no.	334-0KE00
Voltage outputs	✓
Min. load resistance (voltage range)	1 kΩ
Max. capacitive load (current range)	1 μF
Max. inductive load (current range)	25 mA
Output voltage ranges	0 V ... +10 V
Operational limit of voltage ranges	+/-1%
Basic error limit voltage ranges	+/-0.8%
Destruction limit against external applied voltage	max. 16V (30V / 10s)
Current outputs	-
Max. in load resistance (current range)	-
Max. inductive load (current range)	-
Typ. open circuit voltage current output	-
Output current ranges	-
Operational limit of current ranges	-
Basic error limit current ranges	-
Destruction limit against external applied voltage	-
Settling time for ohmic load	0.8 ms
Settling time for capacitive load	0.8 ms
Settling time for inductive load	0.3 ms
Resolution in bit	12
Conversion time	0.5 ms per channel
Substitute value can be applied	-
Output data size	4 Byte
Status information, alarms, diagnostics	
Status display	none
Interrupts	no
Process alarm	no
Diagnostic interrupt	no
Diagnostic functions	no
Diagnostics information read-out	none
Supply voltage display	none
Group error display	none
Channel error display	none

Order no.	334-0KE00
Isolation	
Between channels	-
Between channels of groups to	-
Between channels and backplane bus	✓
Between channels and power supply	✓
Max. potential difference between circuits	-
Max. potential difference between inputs (Ucm)	DC 1 V
Max. potential difference between Mana and Mintern (Uiso)	DC 75 V/ AC 50 V
Max. potential difference between inputs and Mana (Ucm)	DC 1 V
Max. potential difference between inputs and Mintern (Uiso)	-
Max. potential difference between Mintern and outputs	-
Insulation tested with	DC 500 V
Datasizes	
Input bytes	8
Output bytes	4
Parameter bytes	21
Diagnostic bytes	0
Housing	
Material	PPE
Mounting	Rail System 300
Mechanical data	
Dimensions (WxHxD)	40 mm x 125 mm x 120 mm
Weight	210 g
Environmental conditions	
Operating temperature	0 °C to 60 °C
Storage temperature	-25 °C to 70 °C
Certifications	
UL certification	yes
KC certification	yes

Additional Technical data

Order number	334-0KE00
Analog value generation of the inputs	
Basic conversion time	nx72ms
Smoothing of the measured values	none
Suppression of interference, Limits of error of the inputs	
Noise suppression for $f=n \times (f1 \pm 1\%)$ ($f1$ = interference frequency, $n=1,2,\dots$)	
- Common mode interference (UCM <13V)	> 80dB
- Series mode noise (peak value of noise < Nominal value of input range)	> 80dB
Crosstalk between the inputs	> 50dB
Temperature error (with reference to the input range)	$\pm 0.01\%/K$
Linearity error (with reference to the input range)	$\pm 0.005\%$
Repeatability (in steady state at 25°C, referred to input range)	$\pm 0.05\%$
Suppression of interference, Limits of error of the outputs	
Crosstalk between outputs	> 40dB
Temperature error (with reference to the output range)	$\pm 0.005\%/K$
Linearity error (with reference to the output range)	$\pm 0.1\%$
Repeatability (in steady state at 25°C, with reference to the output range)	$\pm 0.05\%$
Output ripple; Range 0 to 50kHz (with reference to the output range)	$\pm 0.05\%$
Data for selecting a sensor	
Maximum input voltage for voltage input (destruction limit)	30V
Connection of the sensor	
- for measuring voltage	possible
- for measuring resistance	
as 2-conductor connection	possible
as 3-conductor connection	possible
as 4-conductor connection	possible
Characteristic linearization	

Order number	334-0KE00
- for resistance thermometer	Pt100 Climate
Temperature compensation	no
Technical unit for temperature measurement	°C
Data for selecting an actuator	
Load resistance (in the nominal range of the outputs)	
- for voltage outputs	min. 1kΩ
- capacitive load	max. 1μF
Destruction limit against voltages/currents	
- Voltages at outputs to M _{ANA}	max. 16V (30V for 10s)
- Current	not possible
Connection of actuators	
- for voltage output	
2-conductor connection	possible
4-conductor connection	not possible

6 Analog I/O Modules FAST - SPEED-Bus

6.1 General

Cables for analog signals

For analog signals you should use isolated cables to reduce interference. The cable screening should be grounded at both ends. If there are differences in the potential between the cable ends, there may occur a potential compensating current that could disturb the analog signals. In this case you should ground the cable screening only at one end.

Connecting sensors

Depending on the module the following sensors may be connected to the analog input modules:

- Current sensor $\pm 20\text{mA}$
- Voltage sensor $\pm 10\text{V}$



Please take care of the correct polarity when installing the sensors! Please install short circuits at non-used inputs by connecting the positive contact with the channel ground of the according channel.

Parameterization

The modules may be parameterized by hardware configuration respectively at run time by means of SFCs.

Diagnostic functions

The modules have diagnostics capability. The following errors can release a diagnostic:

- Error in parameterization
- Process interrupt lost
- Measuring range over-/underflow
- External power supply is missing

Process interrupts

The following events can be defined by parameterization to release a process interrupt:

- Limit overflow
- Limit underflow
- End of cycle as soon as measuring value conversion of every channel has finished.

At a process interrupt 4bytes of process interrupt data are transferred. The process interrupts are deactivated when using oscilloscope- or FIFO functions.

6.2 Analog value representation

Numeric representation in Siemens S7 format

The analog values are only processed by the CPU in binary representation. Hereby the process signals are transformed into digital format in the analog module and passed on to the CPU as word variable. The digitized analog value is the same for input and output values at the same nominal range. The analog value is represented as two's-complement

		Analog value															
		High-Byte								Low-Byte							
Bit number		15	14	13	12	11	10	9	8	7	6	5	4	3	2	1	0
15Bit+SG	SG	Measuring value															

Sign bit (SG)

The algebraic sign bit is represented by Bit 15. Here it is essential:

- Bit 15 = "0" → positive value
- Bit 15 = "1" → negative value

Behavior at error

As soon as a measured value exceeds the overdrive region respectively falls below the underdrive region, the following value is issued:

Measuring value > end of overdrive region: 32767 (7FFFh)

Measuring value < end of underdrive region: -32768 (8000h)

At a parameterization error the value 32767 (7FFFh) is issued.

Digital/analog conversion

In the following there are the measuring ranges listed. The support depends on the analog module. The here listed formulas allow you to transform an evaluated measuring value (digital value) to a value assigned to the measuring range and vice versa.

+/- 10V

Formulas for calculation:

$$D = 27648 \cdot \frac{U}{10}, \quad U = D \cdot \frac{10}{27648}$$

U: voltage, D: Decimal value

+10V	+27648	6C00h
+5V	+13824	3600h
0V	0	0h
-5V	-13824	CA00h
-10V	-27648	9400h

Operating modes

+/- 20mA

Formulas for calculation:

$$D = 27648 \cdot \frac{I}{20}, \quad I = D \cdot \frac{20}{27648}$$

I: current, D: Decimal value

+20mA	+27648	6C00h
+10mA	+13824	3600h
0mA	0	0h
-10mA	-13824	CA00h
-20mA	-27648	9400h

6.3 Operating modes

Mode

There are the following modes at the analog input modules to be set by means of a hardware configuration at the Siemens SIMATIC Manager.

Standard mode

At the standard mode the analog values of the 8 input channels were cyclically read up to 25µs, converted to 16bit digital values and transferred to the CPU via SPEED-Bus. Only for cycle times ≥ 200µs an end of cycle interrupt may be activated. This is generated as soon as there are new measuring values available.

Oscilloscope mode

With the oscilloscope mode the digitized input values were buffered in the memory of the module. There is space for a total of 65536 measuring values. At this mode hardware interrupts are not supported. Recording may be started manually or automatically, whereas there is reacted at a rising respectively falling edge of the measuring signal. As soon as the memory of the module is full the recording ends automatically.

FIFO mode

If FIFO mode is activated the input values of channel CH0 to CH7 are stored at a buffer. There is space for 8190 values each channel. These may cyclically be read in packets. At overflow the memory contents is overwritten from the beginning and an error is reported.

SFC 193

The activation of the oscilloscope-/FIFO function as well as the readout of the stored data happens by means of the VIPA specific SFC 193.

Parameter

There are a lot of parameters to adapt these functions to your requirements. The parameters may be set by GSD file respectively at run time by SFC 58.

6.4 Addressing at SPEED-Bus

Overview

To provide specific addressing of the installed peripheral modules, certain addresses must be allocated in the CPU. With no hardware configuration present, the CPU assigns automatically peripheral I/O addresses during boot procedure depending on the plug-in location amongst others also for plugged modules at the SPEED-Bus.

Maximal pluggable modules

In the hardware configurator from Siemens up to 8 modules per row may be parameterized. At deployment of SPEED7 CPUs up to 32 modules at the standard bus and 10 further modules at the SPEED-Bus may be controlled. CPs and DP masters that are additionally virtual configured at the standard bus are taken into the sum of 32 modules at the standard bus. For the project engineering of more than 8 modules you may use virtual line interface connections. For this you set in the hardware configurator the module IM 360 from the hardware catalog to slot 3 of your 1. profile rail. Now you may extend your system with up to 3 profile rails by starting each with an IM 361 from Siemens at slot 3.

Define addresses by hardware configuration

You may access the modules with read res. write accesses to the peripheral bytes or the process image. To define addresses, a hardware configuration via a virtual PROFIBUS system by including the SPEEDBUS.GSD may be used. For this, click on the properties of the according module and set the wanted address.

Automatic addressing

If you do not like to use a hardware configuration, an automatic addressing comes into force. At the automatic address allocation DI/Os are mapped depending on the slot location with a distance of 4byte and AI/Os, FM/s, CP/s with a distance of 256byte. Depending on the slot location the start address from where on the according module is stored in the address range is calculated with the following formulas:

DIOs: Start address = $4 \times (\text{slot} - 101) + 128$

AI/Os, FM/s, CP/s: Start address = $256 \times (\text{slot} - 101) + 2048$

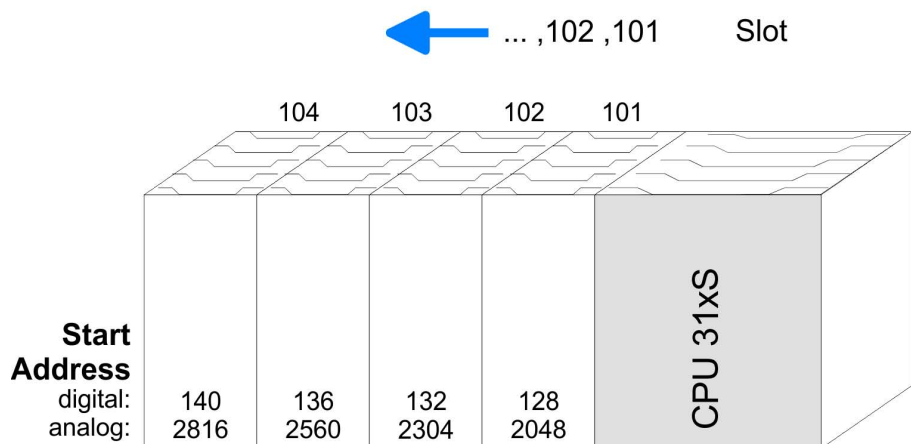

6.5 Project engineering

Overview

Every module at the SPEED-Bus including the CPU has to be configured as single "VIPA_SPEEDBUS" DP slave at a virtual DP master (342-5DA02 V5.0 from Siemens). For this you have to include the SPEEDBUS.GSD. Every "VIPA_SPEEDBUS" DP slave has exactly one slot for the project engineering where you must place the according SPEED-Bus module. The assignment of a SPEED-Bus slave to a SPEED-Bus slot number takes place via the PROFIBUS address starting with 100.

6.5.1 Fast introduction

For the employment of the I/O modules at the SPEED-Bus the inclusion via the GSD-file from VIPA in the hardware catalog is required.

To be compatible with the Siemens SIMATIC manager, you have to execute the following steps:

1. ▶ Start the hardware configurator from Siemens and include the SPEEDBUS.GSD for SPEED7 from VIPA.
2. ▶ Configure the corresponding CPU from Siemens.
3. ▶ Starting with slot 4, place the System 300 modules in the plugged sequence.
4. ▶ Project engineering and connection of the SPEED-Bus-CPs res. DP master at the standard bus as virtual CP 343-1 (343-1EX11) res. CP 342-5 (342-5DA02 V5.0)
5. ▶ For the SPEED-Bus you always include, connect and parameterize to the *operating mode* DP master the DP master CP 342-5 (342-5DA02 V5.0) as last module. To this master system you assign every SPEED-Bus module as VIPA_SPEEDBUS slave. Here the PROFIBUS address corresponds to the slot number beginning with 100 for the CPU. Place at slot 0 of every slave the assigned module and alter the parameters if needed.

Standard bus

Slot	Module
1	
2	CPU ...
X2	...
X1	...
3	

real modules at standard bus

CPs res. DP master at SPEED-Bus

342-5DA02 V5.0

virtual DP master for CPU and all SPEED-Bus modules

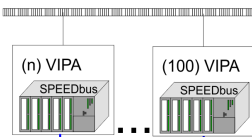

VIPA_SPEEDBUS	
Slot	Order number
0	CPU at slot 100

VIPA_SPEEDBUS

Slot	Order number
0	Module at slot n

6.5.2 Preconditions

The hardware configurator is part of the Siemens SIMATIC manager. It serves for project engineering. The modules that may be configured here are listed in the hardware catalog. For the employment of the System 300S modules at the SPEED-Bus you have to include the System 300S modules into the hardware catalog via the GSD-file SPEEDBUS.GSD from VIPA.



For the project engineering, a thorough knowledge of the Siemens SIMATIC manager and the hardware configurator from Siemens is required!

Include the SPEED7-GSD-file

1. Browse to www.vipa.com 'Service → Download → GSD- and EDS-Files → PROFIBUS' and select the file Cx000023_Vxxx.
2. Extract the file to your work directory. The SPEEDBUS.GSD is stored in the directory System_300S.
3. Start the hardware configurator from Siemens.
4. Close all projects.
5. Select 'Options → Install new GSD-file'.
6. Change to the directory System_300S and select the **SPEEDBUS.GSD**.
 - ⇒ The modules of the System 300S from VIPA are now included in the hardware catalog at: *PROFIBUS DP / Additional field devices / I/O / VIPA_SPEEDBUS*.

6.5.3 Steps of project engineering

The following text describes the approach of the project engineering in the hardware configurator from Siemens at an abstract sample. The project engineering is separated into following parts:

- Project engineering of the modules at the standard bus
- Project engineering of the SPEED-Bus modules in a virtual master system (SPEEDBUS.GSD required)

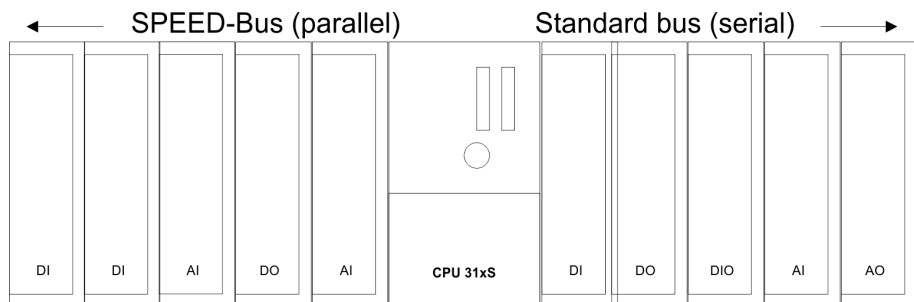

Preconditions

For the employment of the System 300S modules at the SPEED-Bus you have to include the System 300S modules into the hardware catalog via the GSD-file SPEEDBUS.GSD from VIPA.

Project engineering of the modules at the standard bus

The modules at the right side of the CPU at the standard bus are configured with the following approach:

1. Start the hardware configurator from Siemens with a new project and insert a profile rail from the hardware catalog.
2. Place the corresponding Siemens CPU at slot 2.

3. ▶ Include your System 300V modules at the standard bus in the plugged sequence starting with slot 4.
4. ▶ Parameterize the CPU res. the modules where appropriate. The parameter window opens by a double click on the according module.
5. ▶ To extend the bus you may use the IM 360 from Siemens where you can connect up to 3 further extension racks via the IM 361. Bus extensions are always placed at slot 3.
6. ▶ Save your project.

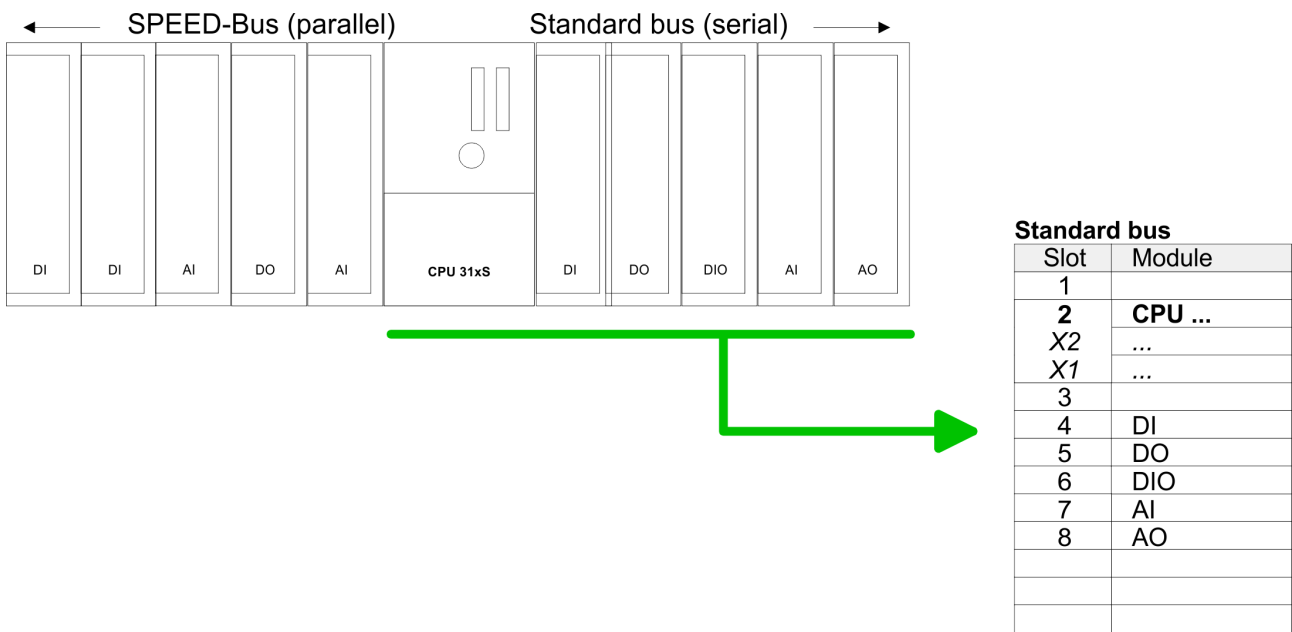

i To extend the bus you may use the IM 360 from Siemens where you can connect up to 3 further extension racks via the IM 361. Bus extensions are always placed at slot 3.

Project engineering of all SPEED-Bus modules in a virtual master system

The slot assignment of the SPEED-Bus modules and the parameterization of the in-/output periphery happens via a virtual PROFIBUS DP master system. For this, place as last module a DP master (342-5DA02 V5.0) with master system. For the employment of the System 300S modules at the SPEED-Bus the inclusion of the System 300S modules into the hardware catalog via the GSD-file SPEEDBUS.GSD from VIPA is required. After the installation of the SPEEDBUS.GSD you may locate under *PROFIBUS DP / Additional field devices / I/O / VIPA_SPEEDBUS the DP slave system VIPA_SPEEDBUS*. Now include for the CPU and every module at the SPEED-Bus a slave system "VIPA_SPEEDBUS". Set as PROFIBUS address the slot no. (100...110) of the module and place the according module from the hardware catalog of VIPA_SPEEDBUS to slot 0 of the slave system.

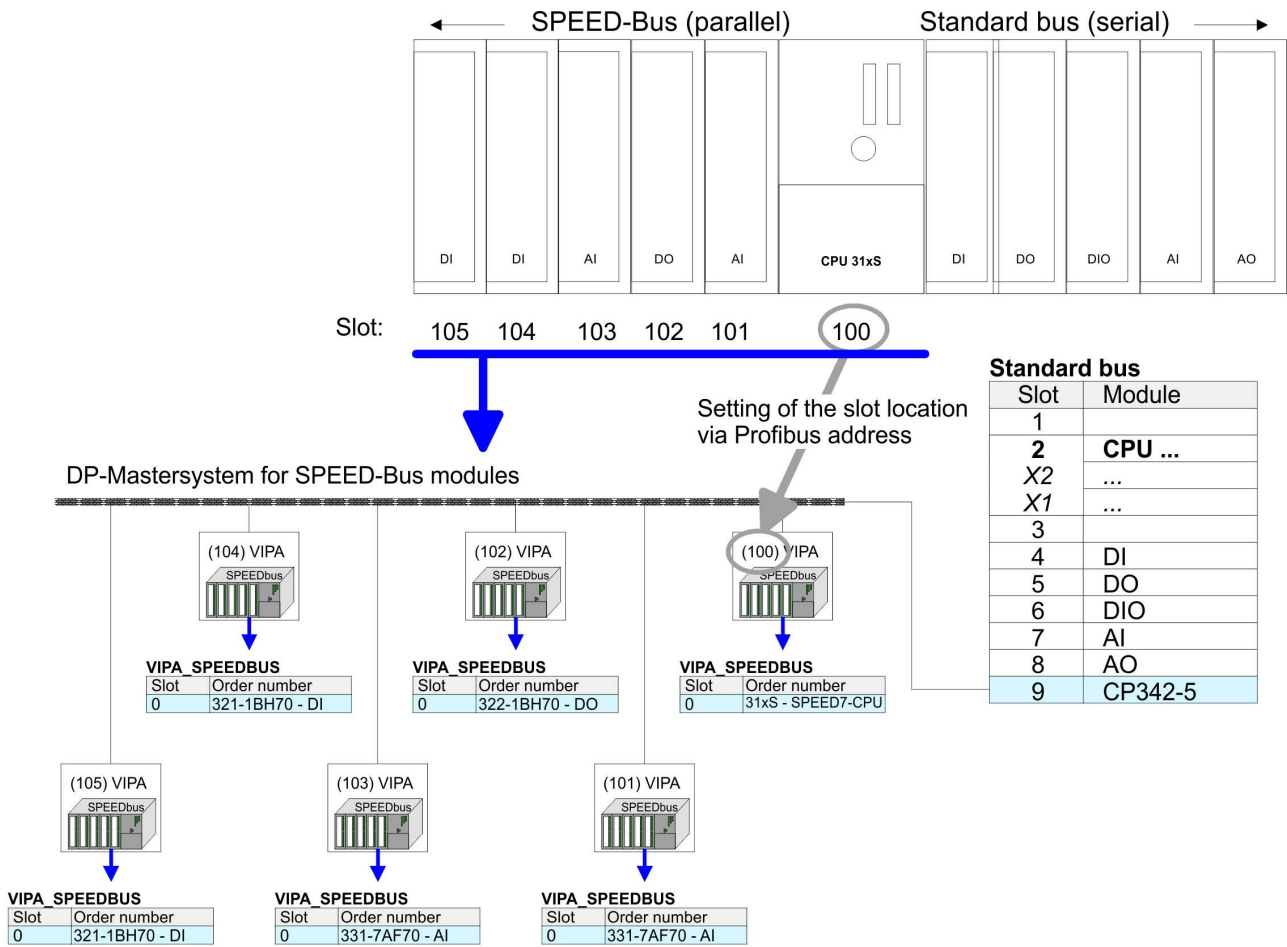

The according module is to be taken over from the HW Catalog of VIPA_SPEEDBUS to slot 0.

6.6 Parameterization

Overview

After PowerON the diagnostics function of every channel is deactivated. For parameterization the parameter data of the module are transferred by the Siemens SIMATIC manager to the CPU. There is also the possibility to change parameters during run time by means of SFCs.

Place module

1. Start the hardware configurator and install speedbus.gse for SPEED7 from VIPA.
2. Configure the corresponding CPU from Siemens.
3. Include your System 300V modules at the standard bus in the plugged sequence starting with slot 4.
4. For the SPEED-Bus you always include, connect and parameterize to the *operating mode* DP master the DP master CP 342-5 (342-5DA02 V5.0) as last module.

- 5. ▶ To this master system you assign every SPEED-Bus module as VIPA_SPEEDbus slave. Here the PROFIBUS address corresponds to the slot number beginning with 100 for the CPU.
- 6. ▶ Place at slot 0 of every slave the assigned module and alter the parameters if needed. In this way also the project engineering of the analog modules takes place.

Parameterize the module

Via double click on the wanted module in the hardware configurator the corresponding parameter dialog is opened. You may alter the following parameters there:

- Start address of the data of the module stored in the CPU
- Enable interrupt/Mode (end of cycle, Oscilloscope-/FIFO mode, diagnostics, limit)
- Limit (upper/lower)
- Oscilloscope parameter (channel, pre-trigger, level, condition)
- Cycle time (scan time at Oscilloscope-/FIFO mode)

Save and transfer project

- Save and compile your project.
- Set your CPU to STOP.
- Transfer your project into the CPU.

As soon as you switch the CPU into RUN, the parameters are transmitted to the analog input module.

6.6.1 Structure of the parameter bytes

The parameterization happens during hardware configuration. Here the following parameter data are transferred:

Length in Byte	Record set	Description
4	A0h	Limit upper/lower channel 0
4	A1h	Limit upper/lower channel 1
...
4	A7h	Limit upper/lower channel 7
2	A8h	Cycle time/(sampling time at oscilloscope-/FIFO mode)
2	7Fh	Interrupt enable/Operating mode
5	BEh	Oscilloscope (Parameter for oscilloscope mode)

Using the SFCs 55, 56, 57 and 58 every parameter of the module may be transferred to the module during run time. Here the favorite parameters are transferred as record set by the user program by means of SFCs. By this parameters may be transferred, which are not supported by the Siemens SIMATIC manager.

**Record set A0...A7h
Limit upper/lower**

Upper and lower limits may be set for the corresponding channel by record set A0h...A7h. As soon as your measured value leaves the work area defined by the limit values, a limit value interrupt is released, if activated. The record set has the following structure:

Word		Default	
		Byte 0	Byte 1
0	Limit upper	7FFFh	
2	Limit lower	8000h	

Record set A8h Cycle time/Sampling time

With this record set a factor may be set, which sets the cycle time multiplied by 100µs, this is independent of the number of activated channels. The cycle time of 25µs is set by 0. During hardware configuration the cycle time may be directly chosen. Is oscilloscope respectively FIFO mode activated this time represents the sampling time the read values are stored. *Range of values: 0 ... 600* The record set has the following structure:

Word		Default	
		Byte 0	Byte 1
0	Cycle time/sampling time	0001h	

As soon as this record set is transferred during recording at oscilloscope or FIFO operation the recording is stopped.

Record set 7Fh Interrupt enable/Operating mode

Here the interrupt behavior and the operating mode of the module may be adjusted. Is the diagnostic interrupt deactivated during run-time and a diagnostic interrupt is just pending, there may no diagnostic_{going} be generated to reset the SF-LED. Please do not execute a diagnostic interrupt deactivation during run time! As soon as this record set is transferred during recording at oscilloscope or FIFO operation the recording is stopped. The record set has the following structure:

Byte	Bit 7 ... Bit 0	Default
0	Interrupt enable/Operating mode <ul style="list-style-type: none"> ■ Bit 0: reserved ■ Bit 5 ... 1: Operating mode <ul style="list-style-type: none"> – 00000: without end of cycle interrupt – 00010: with end of cycle interrupt – 00100: Oscilloscope: Channel 0 – 01000: Oscilloscope: Channels 0 ... 1 – 01100: Oscilloscope: Channels 0 ... 3 – 10000: Oscilloscope: Channels 0 ... 7 – 00001: FIFO mode ■ Bit 6: Diagnostic interrupt enable ■ Bit 7: reserved 	00h
1	Limit interrupt enable <ul style="list-style-type: none"> ■ Bit 0: Channel 0 ■ ... ■ Bit 7: Channel 7 	00h

with/without end of cycle interrupt

Setting *with or without* end of cycle interrupt the module may be used in standard operating mode. Here the 8 channels are read synchronously and allocated as 16bit value. Setting *with end of cycle interrupt* an end of cycle interrupt is generated as soon as new measuring values are available. Please note that end of cycle monitoring is only available starting from a module cycle time of 200µs.

Oscilloscope operating mode

In the oscilloscope mode the fragmentation of the memory is configured by number of channels to be recorded. The memory has a total space for 65536 measuring values. For memory fragmentation see the following table:

Byte 0, Bit 5 ... 1	Operating mode	Channel	Number of words	Values each channel
0 0100	Oscilloscope: Ch. 0	CH0	1 x 64 k	65.536
0 1000	Oscilloscope: Ch. 0 ... 1	CH0, CH1	2 x 32 k	32.768
0 1100	Oscilloscope: Ch. 0 ... 3	CH0 ... CH3	4 x 16 k	16.384
1 0000	Oscilloscope: Ch. 0 ... 7	CH0 ... CH7	8 x 8 k	8.192

FIFO operating mode

During FIFO operation all of the 8 channels are recorded and stored at a buffer. These values may be read as packets by means of the user program. At overflow the memory contents is overwritten from the beginning and an error is reported by *RETVAl*. The buffer offers place for 8190 values per channel.

Diagnostic interrupt enable With activated diagnostic interrupt, in the case of an error and after error correction a diagnostic interrupt is released to the CPU. With a diagnostic interrupt the CPU interrupts its user program and jumps to OB 82. There detailed diagnostic information can be requested by means of the SFC 51 respectively SFC 59. The diagnostics data are consistent during OB 82 operation.

Limit interrupt enable A work area may be defined by the parameters *limit upper/lower*. If your measuring signal leaves this work area and the limit interrupt is enabled, then the module releases a process interrupt of the corresponding channel. Here the CPU interrupts its user program and jumps to OB 40. There it may be reacted accordingly to the process interrupt. With leaving the OB 40 the process interrupt is acknowledged at the corresponding module. Please note that at oscilloscope-/FIFO operating mode the process interrupts are not supported.

Record set BEh Oscilloscope The parameters of the oscilloscope operation may be set with this record set. As soon as this record set is transferred during recording at oscilloscope or FIFO operation the recording is stopped. The record set has the following structure:

Byte	Bit 7 ... 0	Default
0	<ul style="list-style-type: none"> ■ Bit 2 ... 0: Trigger channel <ul style="list-style-type: none"> – 000: CH0 – 111: CH7 ■ Bit 7 ... 3: reserved 	00h
1	<ul style="list-style-type: none"> ■ Bit 6 ... 0: Pre-trigger (%) <ul style="list-style-type: none"> – 00h: 0% Pre-trigger – ... – 64h: 100% Pre-trigger ■ Bit 7: reserved 	00h
2, 3	<ul style="list-style-type: none"> ■ Bit 15 ... 0: Trigger level <ul style="list-style-type: none"> – 8100h: -32512 (decimal) – ... – 0000h: 0 – ... – 7EFFh: 32511 (decimal) 	00h
4	<ul style="list-style-type: none"> ■ Bit 1 ... 0: Trigger condition <ul style="list-style-type: none"> – 00: rising edge (automatic start) – 01: falling edge (automatic start) – 10: manual start ■ Bit 7 ... 2: reserved 	00h

Trigger channel With this parameter a channel may be defined to be triggered, this means the recording is to be started on its rising or falling edge. At manual operation this setting will be ignored.

Pre-trigger (%) Here a number per cent may be set as pre-trigger. On this way values may also be picked out, which were buffered before the trigger event occurred. At manual operation this setting will be ignored. In the following there is a formula to calculate the number n of values in the buffer, which were buffered before the trigger event occurred. This value depends on the parameters pre-trigger and the number of channels to be buffered.

$$n = \frac{8192 \times \text{Pre-trigger}}{100} \times \frac{8}{\text{Number channels}}$$

Integer

Trigger level At this parameter a threshold may be set, which when exceeded/fallen below generates a trigger event. At manual operation this setting will be ignored.

Trigger condition Here the start condition for recording may be set. To start the recording there is basically differentiated between an automatic operation with a triggered edge and a manual operation.

SFC 193 for controlling The oscilloscope/FIFO operation is controlled by means of the SFC 193. This is described at the following pages.

6.7 SFC 193 - Oscilloscope-/FIFO function

Description The SFC 193 serves for controlling the Oscilloscope-/FIFO function. It allows to start the recording and to read the buffered data. Depending upon the parameterization there are the following possibilities:

Oscilloscope operation

- Depending on the trigger condition at edge evaluation the monitoring of the configured channel may be started respectively at manual operation the recording may be started.
- The recorded measuring values may be accessed by the SFC 193 as soon as the buffer is full.

FIFO operation

- Start the recording
- Read the puffer at any time



The SFC may only be called from on level of priority e.g. only from OB 1 or OB 35. The module is to be parameterized before. For starting and reading in each case the SFC 193 is to be called. The differentiation of both variants takes place in the parameter *MODE*.

Parameters

Parameter	Declaration	Data type	Function depending on <i>MODE</i>
REQ	IN	BOOL	Execute function (start/read)
LADR	IN	WORD	Base address of the module
MODE	IN	WORD	Mode (start/read)
CHANNEL	IN	BYTE	Channel to be read
OFFSET	IN	DWORD	Address offset for reading (not FIFO operation)
RECORD	IN	ANY	Memory for the read data
RETVAL	OUT	WORD	Return value (0=OK)
BUSY	OUT	BOOL	Function is busy
TIMESTAMP	OUT	DWORD	Time stamp (only at edge evaluation)
LEN	INOUT	DWORD	Number of values to be handled per channel

REQ

Depending on the set *MODE* when the bit is set the recording respectively the reading may be started. Depending on the trigger condition at edge evaluation the monitoring of the configured channel may be started respectively at manual operation the recording may be started. The data are read from the module, if "read" is set at *MODE*.

LADR

Logical basic address of the module

MODE

The SFC 193 may be called with 3 different modes. The corresponding mode may be set by the parameter *MODE*. The configured mode is executed by setting REQ. The following values are supported:

- 01h: Starts recording respectively edge monitoring depending upon the parameterization.
- 00h: Read data within several cycles until BUSY = 0.
- 80h: Read data with one access.

CHANNEL

Here the channel is specified to be read. With each call one channel may be read. This parameter is irrelevant at start calls with *MODE* = 01h.

- OFFSET** Offset specifies an address offset for the reading process. By this you get access to sub-ranges of the recorded data. The value for the maximum offset depends on the number of values, which were recorded per channel. *OFFSET* is not supported in FIFO operation. It will be ignored.
- RECORD** Here an area for the read values to be stored at may be defined. In FIFO operation every value of the selected channel may be read, which were stored up to the time of start reading. Please regard that the buffer has a sufficient size for the data to be buffered, otherwise an error is reported.
- BUSY** *BUSY* = 1 indicates that the function just processed. *BUSY* = 0 indicates that the function is finished.
- TIMESTAMP** There is an internal clock with a resolution of 1µs running in every SPEED-Bus module. The returned value corresponds to the time at the SPEED-Bus module, on which the trigger event occurred. *TIME-STAMP* is only available at the edge triggered Oscilloscope operation. It is valid as long as the job is running (*RETV* = 7xxxh) and bit 4 of byte 0 is set respectively the job has been finished without an error (*RETV* = 0000h).
- LEN** The length parameter realized as IN/OUT is variably interpreted depending on the selected mode at the function call.
Mode: start (MODE: = 01h)
 At *MODE* = 01h this parameter may only be used at the manual Oscilloscope start. Here the requested number of values per channel to be buffered may be assigned. In this mode there is no value reported by *LEN*.
Mode: read (MODE: = 00h or 80h)
 At *MODE* = 00h respectively 80h the number of values to be read may be set. This parameter is ignored in FIFO operation. The number of the read values is returned by *LEN*.
- RETV (Return value)** In addition to the module specific error codes listed here, there general SFC error information may be returned as well. More may be found at the operation list.

RETV	Description depending on the BUSY-Bit	BUSY
Byte		
0	<ul style="list-style-type: none"> ■ Bit 1, 0: 00: Call with REQ: = 0 (idle, waiting for REQ = 1) 01: First call with REQ: = 1 10: Subsequent call with REQ: = 1 	<ul style="list-style-type: none"> 0 1 1

RETVAL	Description depending on the BUSY-Bit	BUSY
	11: Oscilloscope is just recording.	1
	■ Bit 2: REQ: = 1, but recording was not yet started. (MODE: = 00h or MODE: = 80h)	0
	■ Bit 3: reserved	-
	■ Bit 4: Trigger event occurred and recording is just running.	1
	■ Bit 5: Waiting for trigger event	1
	■ Bit 7 ... 6: reserved	-
1	■ Bit 0: reserved	-
	■ Bit 1: The number of recorded values exceeds the target area defined by RECORD (in words).	0
	■ Bit 2: The number of the recorded values exceeds the area defined by <i>LEN</i> and <i>OFFSET</i> .	0
	■ Bit 3: Buffer overflow in FIFO operation.	0
	■ Bit 7 ... 4:	
	0000: Job finished without an error	0
	0111: Job still running	1
1000: Job finished with error (see following table)	0	

Job finished without an error

RETVAL	Description depending on the BUSY-Bit	BUSY
0000h	Job was finished without an error.	0

Job finished with error

RETVAL	Description depending on the BUSY-Bit	BUSY
8002h:	Oscilloscope-/FIFO function is not configured.	0
8003h:	An internal error occurred - please contact VIPA.	0
8005h:	The selected channel may not be read - wrong channel number.	0
8007h:	The value at <i>OFFSET</i> exceeds the number of recorded values.	0
8090h:	There is no SPEED-Bus module with this address available.	0
80D2h:	LADR exceeds the peripheral address area.	0

Example for the Oscilloscope function

6.8 Example for the Oscilloscope function

Job definition

At this example 4 channels were recorded with 25 μ s sampling time whereas channel 2 is monitored. As soon as the decimal value 12000 is exceeded by the input signal, a trigger event is generated. 50% of the buffer should contain the last values before the trigger event occurred (pre-trigger) and 50% the values after the event.

Parameterization

The parameterization happens by a hardware configuration of the Siemens SIMATIC manager. Here the integration of the VIPA GSD file speedbus.gse is necessary. More may be found above at "Project engineering". Parameterize the following module parameters after configuring the system:

Cycle time: 25 μ s

Operating mode: Oscilloscope Channels 0 ... 3

(16384 values per channel)

Oscilloscope trigger channel: 2

Oscilloscope pre-trigger (%): 50

Oscilloscope trigger level: 12000

Oscilloscope trigger condition: rising edge

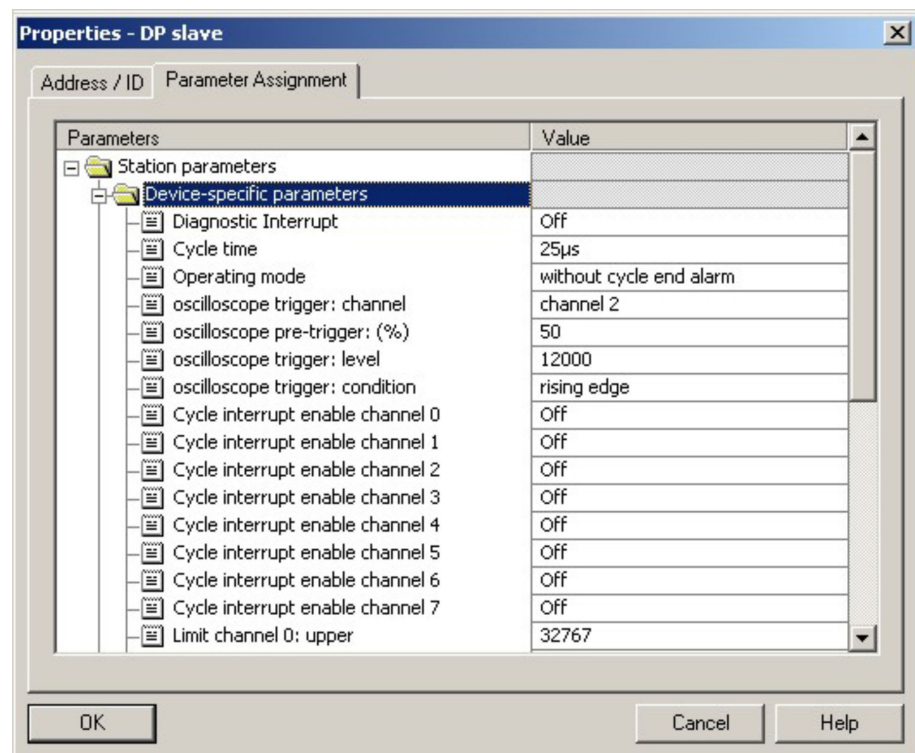

User program

The SFC 193 calls for starting the oscilloscope recording and for reading the data are implemented in the OB 1 of the user program. For the simplified representation and for controlling the parameters are handled in a variable table.

```
CALL SFC 193 // start oscilloscope function (1. SFC call)
```

```
REQ :=M99.0 // bit to start recording
```



```

LADR :=W#16#64 // basic module address
MODE :=W#16#1 // mode: start
CHANNEL :=B#16#0 // not used
OFFSET :=DW#16#0 // not used
RECORD :=DB10 // not used
RETVAL :=MW1110 // return value
BUSY :=M112.0 // busy bit
TIMESTAMP:=MD100 // not used
LEN :=MD114 // length parameter for recording
// (only at "manual start")
U M 99.0 // request bit set by 1. call?
S M 98.1 // yes: set request bit for 2. call
R M 99.0 // Reset request bit for 1. call
CALL SFC 193 // read data (2. SFC call)
REQ :=M98.1 // bit for reading the data
LADR :=W#16#64 // basic module address
MODE :=W#16#80 // mode: read (complete, 1 access)
CHANNEL :=MB148 // channel to be read
OFFSET :=MD150 // address offset for reading
RECORD :=DB10 // data block for the read values
RETVAL :=MW110 // return value
BUSY :=M112.0 // busy bit
TIMESTAMP:=MD104 // timestamp at trigger event
LEN :=MD114 // length parameter for reading
U M 98.1 // request bit set and
U M 112.0 // busy bit set?
BEB // yes: reading is not yet finished; finish block
U M 98.1 // request bit is set and
UN M 112.0 // busy bit is not set?
SPBN end // no: jump to label end
L MW 110 // yes: load return value and
T MW 160 // transfer to flag
end: NOP 0
U M 98.1
R M 98.1 // reset request bit from 2. call

```

Example for the Oscilloscope function > Example for the FIFO function

Process

The recording at oscilloscope operation is started by setting flag 99.0. From this moment on the configured monitoring of channel 2 on the rising edge and the threshold of 12000 begins. With the configured operation mode *Oscilloscope channels 0 ... 3* these channels are recorded, 16384 values each channel. Exceeding the configured threshold 12000 a trigger event is released. With the pre-trigger of 50% 8192 values per channel were finally recorded, then the recording is finished and the *BUSY* bit is reset. Now the data may be read. With the configured pre-trigger of 50% the 8193. value is the value, which released the event. Further reading accesses with e.g. other address offsets or to read values of the other channels may be executed by setting flag 98.1. The oscilloscope recording may be started again by setting flag 99.0.

Variable table

The output of the values 8189 ... 8208 is generated by the address offset of 8188 and the length of 20. The event was released by the 8193. value (DB10.DBW 8 = 12004), because it has exceeded the configured threshold of 12000.

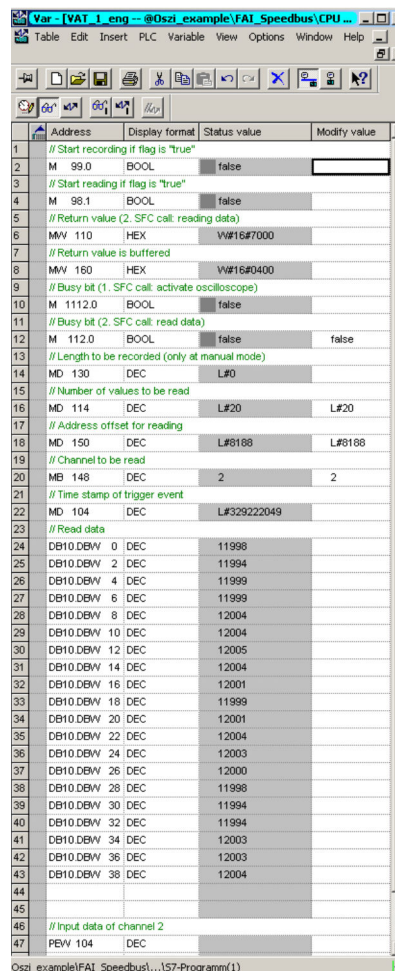

6.8.1 Example for the FIFO function

Job definition

At this example the recorded values of channel 0 were read and the minimum and maximum input value is evaluated.

Parameterization

The parameterization happens by a hardware configuration of the Siemens SIMATIC manager. Here the integration of the VIPA GSD file speedbus.gsd is necessary. More may be found above at "Project engineering". Parameterize the following module parameters after configuring the system:

Cycle time: 100 µs

Operating mode: FIFO

The oscilloscope parameters (channel, pre-trigger, level, condition) are not necessary for FIFO operation and were ignored.

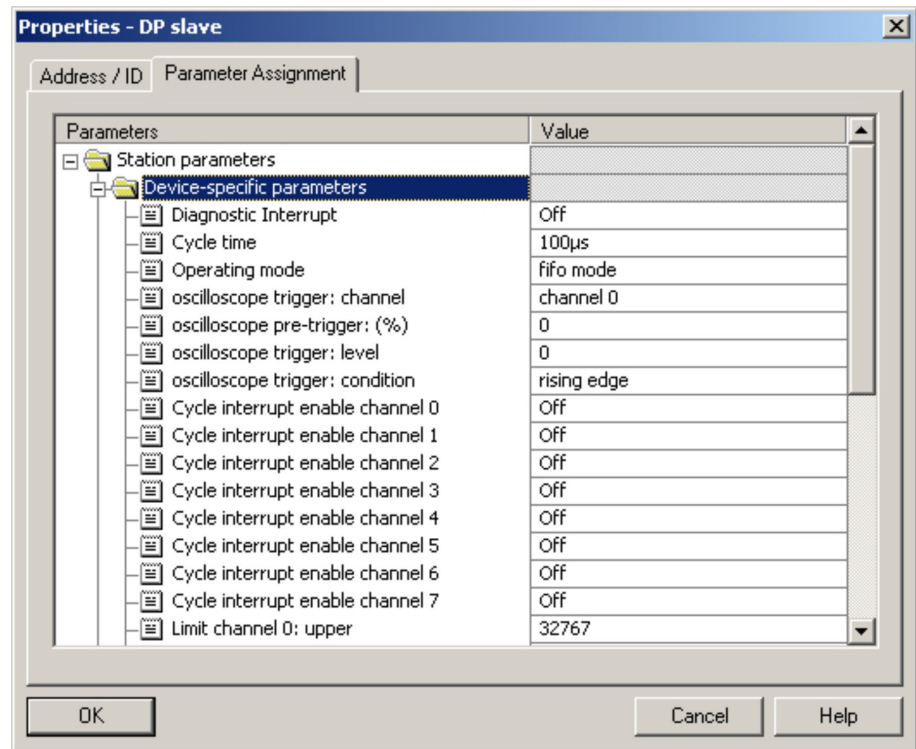

User program

The SFC 193 calls for starting the FIFO operation and for reading the data are implemented in the OB 35. The OB 35 is to be parameterized that it is cyclically called for operation every 10ms. For the simplified representation and for controlling the parameters are handled in a variable table.

```

UN M 20.0 // start bit set?
SPB go // no: do not start FIFO function
L 0 // yes: initialize limits and start FIFO function
L 32767
T MW 46 // initialize minimum value
L -32768
T MW 48 // initialize maximum value
CALL SFC 193 // start FIFO function (1. SFC call)
REQ :=TRUE // bit starting the FIFO function
LADR :=W#16#64 // basic module address
    
```

 Example for the Oscilloscope function > Example for the FIFO function

```

MODE :=W#16#1 // mode: start
CHANNEL :=B#16#0 // not used
OFFSET :=DW#16#0 // not used
RECORD :=DB1 // not used
RETVAL :=MW22 // return value
BUSY :=M20.1 // busy bit
TIMESTAMP:=MD24 // not used
LEN :=MD28 // not used
U M 20.0 // reset start bit
R M 20.0
S M 20.2 // start reading if FIFO active
go: UN M 20.2 // bit set for reading?
BEB // no: finish block
CALL SFC 193 // read data (2. SFC call)
REQ :=TRUE // bit for reading the data
LADR :=W#16#64 // basic module address
MODE :=W#16#80 // mode: read (complete, 1 access)
CHANNEL :=MB21 // channel to be read
OFFSET :=DW#16#0 // not used
RECORD :=DB1 // data block for the read values
RETVAL :=MW32 // return value
BUSY :=M20.3 // busy bit
TIMESTAMP:=MD34 // not used
LEN :=MD38 // length parameter for reading
L MD 38 // load length parameter
L 0
==D // check if values were read
BEB // no: finish block
// every value in the buffer was read
// and stored in DB 1
L P#0.0 // set pointer to the 1. value of DB 1
T MD 42 // store pointer in flag
AUF DB 1 // open DB 1
// Check for new minimum:
loop: L DBW [MD 42 // load input value from DB
L MW 46 // load previous minimum value
>=I // is the input value exceeding // the previous minimum?

```

```

SPB max // yes: check for maximum
TAK // no: exchange accu1 and accu2 - then the measuring value is
in // accu1 again
T MW 46 // store new minimum in flag //Check for a new maximum:
max: L DBW [MD 42] // load input value from DB
L MW 48 // load previous maximum
<=I // is the input value less the
// previous maximum?
SPB ex // yes: next value
TAK // no: exchange accu1 and accu2 -
// then the measuring value is in accu1 again
T MW 48 // store new maximum in flag
ex: NOP 0 // Set pointer to the next value in DB 1:
L MD 42 // load pointer from flag
L P#2.0 // 2bytes because the input values were // stored as words
in the DB 1
+D // increment pointer
T MD 42 // store pointer in flag
// Compare pointer with length of read data:
SRD 4
L MD 38 // number of read values
<D // Does the pointer point to a valid field
// in the DB 1?
SPB loop // yes: check next value

```

Process

The recording at FIFO operation is started by setting flag 20.0. From this moment on the whole buffered input values of channel 0 were every 10ms cyclically read and stored in the data block. The evaluation for minimum and maximum is executed in a loop. Here the number of read values and so the number of necessary loop operations is represented by the parameter *LEN*. After evaluation of the whole read data the OB 35 is finished.

Variable table

The recording at FIFO operation is started by setting flag 20.0. The cyclic read access is indicated by flag 20.2. The channel to be read may be defined by flag 21. At a cyclic read access every 10ms and a sample time of 100µs about 100 values may be read from the buffer. The number of read values is reported in flag 38. The minimum respectively maximum value may be found in the flag word 46 respectively 48.

Address	Display format	Status value	Modify value
1	// Start of FIFO function if flag is "true"		
2	M 20.0	BOOL	false
3			
4	// Data are read if "true"		
5	M 20.2	BOOL	true
6			
7	// Return value of start call		
8	MW 22	HEX	W#16#0000
9			
10	// Channel to be read		
11	MB 21	DEC	0
12			
13	// Return value while reading		
14	MW 32	HEX	W#16#0000
15			
16	// Number of read values		
17	MD 38	DEC	L#100
18			
19	// Determined minimum		
20	MW 46	DEC	-4802
21			
22	// Determined maximum		
23	MW 48	DEC	12806
24			
25	// Input values of the channels		
26	PEW 100	DEC	9731
27	PEW 102	DEC	6
28	PEW 104	DEC	6
29	PEW 106	DEC	3
30	PEW 108	DEC	7
31	PEW 110	DEC	5
32	PEW 112	DEC	5
33	PEW 114	DEC	3
34			
35			

6.9 Diagnostics

Overview

A diagnostic is an error message to a superordinated system (CPU). If enabled by parameterization the following events can release a diagnostic interrupt:

- Error in parameterization
- Process interrupt lost
- Measuring range over-/underflow
- External power supply is missing

At a diagnostic interrupt the CPU interrupts the user application and jumps to the OB 82. Within this OB you can accordingly react to the requested diagnostics information of the module. In the case of an error diagnostic_{coming} and with correction diagnostic_{going} is released.

Error indication via measuring value and LEDs

The module sends the measuring value 7FFFh at overflow, when recognizing a parameterization error or power supply is missing and 8000h at underflow. The group error LED (SF) indicates an error, if the diagnostics interrupt is activated.

Evaluating the diagnostics

At a diagnostics event the CPU interrupts the user program and jumps into the OB 82. This OB allows you via according programming to request detailed diagnostic information with record set 0 and 1 by means of the SFCs 51 and 59 and react to it. After processing of the OB 82, the processing of the user application is continued. The diagnostic data are consistent until leaving the OB 82. As soon as you have enabled the diagnostic interrupt, *record set 0* is transferred to the superordinated system in cause of an error. The *record set 0* has a fixed content and a length of 4byte. The content of *record set 0* may be monitored in plain text in the diagnosis window of the CPU. For extended diagnostics during run time, you may also evaluate the *record set 1* of 16byte length via SFCs 51 and 59. Record set 0 and 1 have the following structure:

Diagnostics record set 0

Record set 0 (Byte 0 ... 3):

Byte	Bit 7 ... Bit 0	Default
0	<ul style="list-style-type: none"> ■ Bit 0: Error in module ■ Bit 1: Internal error ■ Bit 2: External error ■ Bit 3: Channel error ■ Bit 4: External power supply is missing ■ Bit 6, 5: reserved ■ Bit 7: Wrong parameters in module 	00h
1	<ul style="list-style-type: none"> ■ Bit 3 ... 0: Module class <ul style="list-style-type: none"> – 0101 Analog module ■ Bit 4: Channel information present ■ Bit 7 ... 5: reserved 	15h
2	reserved	00h
3	<ul style="list-style-type: none"> ■ Bit 5 ... 0: reserved ■ Bit 6: Process interrupt lost ■ Bit 7: reserved 	00h

Diagnostics record set 1

Byte 0 ... 15: The record set 1 contains the 4byte of record set 0 and additionally 12byte module specific diagnostic data. The diagnostic bytes have the following assignment:

Record set 1 (Byte 0 ... 15):

Byte	Bit 7 ... Bit 0	Default
0 ... 3	Content record set 0 ↪ 'Diagnostics record set 0' on page 151	-
4	<ul style="list-style-type: none"> ■ Bit 6 ... 0: Channel type <ul style="list-style-type: none"> – 70h: Digital input – 71h: Analog input – 72h: Digital output – 73h: Analog output – 74h: Analog in-/output ■ Bit 7: More channel types present <ul style="list-style-type: none"> – 0: no – 1: yes 	71h
5	■ Bit 7 ... 0: Number of diagnostic bits, that the module throws per channel	08h
6	■ Bit 7 ... 0: Number of similar channels of a module	08h
7	<ul style="list-style-type: none"> ■ Bit 0: Channel error Channel 0 ■ ... ■ Bit 7: Channel error Channel 7 	00h
8	<ul style="list-style-type: none"> ■ Bit 0: Project engineering/Parameterization error Channel 0 ■ Bit 5 ... 1: reserved ■ Bit 6: Underflow Channel 0 ■ Bit 7: Overflow Channel 0 	00h
...	...	
15	<ul style="list-style-type: none"> ■ Bit 0: Project engineering/Parameterization error Channel 7 ■ Bit 5 ... 1: reserved ■ Bit 6: Underflow Channel 7 ■ Bit 7: Overflow Channel 7 	00h

6.9.1 Process interrupts

When a process interrupt occurs, the CPU interrupts the user application and jumps to OB 40. Within the OB 40 there is the possibility to get the basic address of the module, which released the process interrupt by means of the local word 6. At the operation mode oscilloscope-/FIFO the process interrupts are deactivated.

Activator

The following releases for a process interrupt may be defined during parameterization:

- Limit overflow
- Limit underflow
- End of cycle as soon as measuring value conversion of every channel has finished.

Interrupt data

The interrupt data of the module may be accessed by local double word 8. The local double word 8 has the following structure:

Local double word 8	Bit 7...0
Byte 0	Upper limit overflow <ul style="list-style-type: none"> ■ Bit 0: Channel 0 ■ ... ■ Bit 7: Channel 7
Byte 1	Lower limit underflow <ul style="list-style-type: none"> ■ Bit 0: Channel 0 ■ ... ■ Bit 7: Channel 7
Byte 2	Event end of cycle <ul style="list-style-type: none"> ■ Bit 2 ... 0: reserved ■ Bit 3: End of cycle reached ■ Bit 7 ... 4: reserved
Byte 3	reserved

In the following illustration the interrupt behavior during limit value is exceeded is graphically represented:

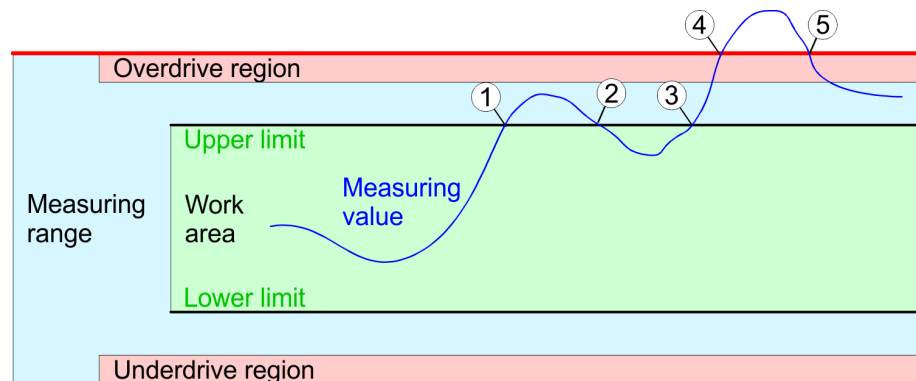

- 1 Process interrupt limit value is exceeded
- 2 no reaction
- 3 Process interrupt limit value is exceeded
- 4 Diagnostic interrupt_{coming} overflow channel
- 5 Diagnostic interrupt_{going} overflow channel

6.10 331-7AF70 - AI 8x16Bit I

Properties

The analog input modules transform analog signals from the process into digital signals for the internal processing. The modules are preset to one measuring range.

- 8 inputs
- Oscilloscope-/FIFO-Function parameterizable
- The 8 inputs are read synchronous
- Measuring value resolution 15bit + sign

- Suitable for sensors $\pm 20\text{mA}$
- Parameterizable diagnostic and process interrupt
- Isolated to the backplane bus and between the channels

Default settings

After PowerON the diagnostics function of every channel is deactivated.

Structure

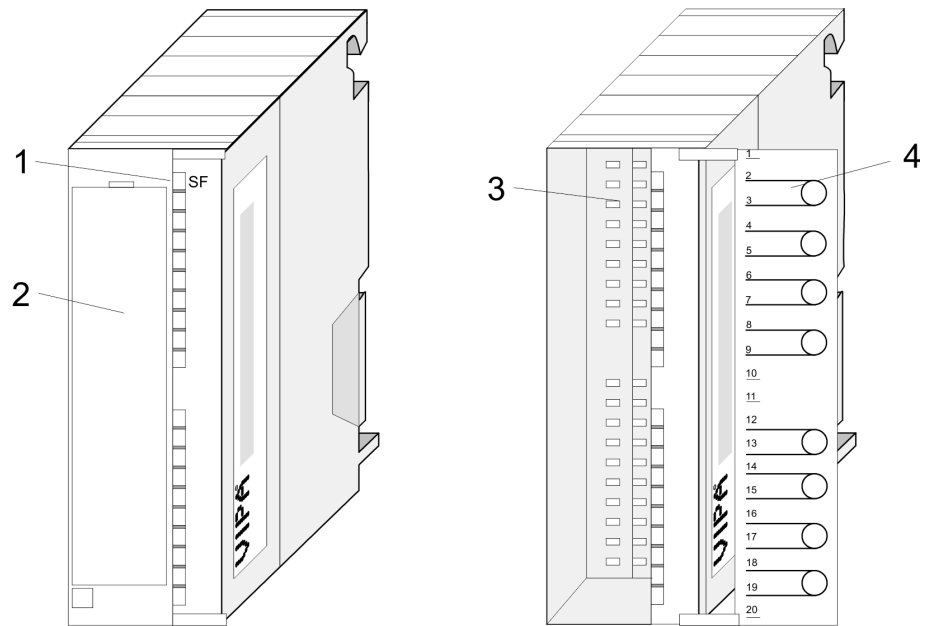

- 1 LEDs
- 2 flap with labeling strip
- 3 contact bar
- 4 flap opened with inner label

Pin assignment/LED

Pin	Assignment	Connection	331-7AF70	LED	Description
1	Power supply DC 24V	1 — L+		SF	LED (red) Group error, ON as soon as a diagnostic entry is present
2	+ Channel 0	2 —			
3	Ground Channel 0	3 —			
4	+ Channel 1	4 —			
5	Ground Channel 1	5 —			
6	+ Channel 2	6 —			
7	Ground Channel 2	7 —			
8	+ Channel 3	8 —			
9	Ground Channel 3	9 —			
10	n.c.	10 —			
11	n.c.	11 —			
12	+ Channel 4	12 —			
13	Ground Channel 4	13 —			
14	+ Channel 5	14 —			
15	Ground Channel 5	15 —			
16	+ Channel 6	16 —			
17	Ground Channel 6	17 —			
18	+ Channel 7	18 —			
19	Ground Channel 7	19 —			
20	Power supply Ground	20 — M			

 **CAUTION!** Please regard that the modules described here do not have hardware precautions against wrong wiring. The modules are fix preset to one measuring range. For example, the modules may get a defect if you connect a voltage at current measuring module.

6.10.1 Technical data

Order no.	331-7AF70
Type	SM 331S - SPEED-Bus
SPEED-Bus	✓
Current consumption/power loss	
Current consumption from backplane bus	530 mA
Power loss	4 W
Technical data analog inputs	
Number of inputs	8
Cable length, shielded	50 m
Rated load voltage	DC 24 V
Current consumption from load voltage L+ (without load)	62 mA
Voltage inputs	-
Min. input resistance (voltage range)	-
Input voltage ranges	-
Operational limit of voltage ranges	-
Operational limit of voltage ranges with SFU	-
Basic error limit voltage ranges	-
Basic error limit voltage ranges with SFU	-
Destruction limit voltage	-
Current inputs	✓
Max. input resistance (current range)	100 Ω
Input current ranges	-20 mA ... +20 mA
Operational limit of current ranges	+/-0.6%
Operational limit of current ranges with SFU	-
Grundfehlergrenze Strombereiche	+/-0.4%
Radical error limit current ranges with SFU	-
Destruction limit current inputs (electrical current)	max. 40mA
Destruction limit current inputs (voltage)	max. 30V
Resistance inputs	-
Resistance ranges	-
Operational limit of resistor ranges	-
Operational limit of resistor ranges with SFU	-
Basic error limit	-

Order no.	331-7AF70
Basic error limit with SFU	-
Destruction limit resistance inputs	-
Resistance thermometer inputs	-
Resistance thermometer ranges	-
Operational limit of resistance thermometer ranges	-
Operational limit of resistance thermometer ranges with SFU	-
Basic error limit thermoresistor ranges	-
Basic error limit thermoresistor ranges with SFU	-
Destruction limit resistance thermometer inputs	-
Thermocouple inputs	-
Thermocouple ranges	-
Operational limit of thermocouple ranges	-
Operational limit of thermocouple ranges with SFU	-
Basic error limit thermoelement ranges	-
Basic error limit thermoelement ranges with SFU	-
Destruction limit thermocouple inputs	-
Programmable temperature compensation	-
External temperature compensation	-
Internal temperature compensation	-
Temperature error internal compensation	-
Technical unit of temperature measurement	-
Resolution in bit	16
Measurement principle	successive approximation
Basic conversion time	25 µs all channels
Noise suppression for frequency	-
Initial data size	16 Byte
Status information, alarms, diagnostics	
Status display	none
Interrupts	yes
Process alarm	yes, parameterizable
Diagnostic interrupt	yes, parameterizable

Order no.	331-7AF70
Diagnostic functions	yes
Diagnostics information read-out	possible
Supply voltage display	none
Group error display	red SF LED
Channel error display	none
Isolation	
Between channels	✓
Between channels of groups to	1
Between channels and backplane bus	✓
Between channels and power supply	✓
Max. potential difference between circuits	-
Max. potential difference between inputs (Ucm)	DC 30 V
Max. potential difference between Mana and Mintern (Uiso)	-
Max. potential difference between inputs and Mana (Ucm)	-
Max. potential difference between inputs and Mintern (Uiso)	DC 75 V/ AC 50 V
Max. potential difference between Mintern and outputs	-
Insulation tested with	DC 500 V
Datasizes	
Input bytes	16
Output bytes	0
Parameter bytes	41
Diagnostic bytes	16
Housing	
Material	PPE
Mounting	DIN rail SPEED-Bus
Mechanical data	
Dimensions (WxHxD)	40 mm x 125 mm x 120 mm
Weight	210 g
Environmental conditions	
Operating temperature	0 °C to 60 °C
Storage temperature	-25 °C to 70 °C

Order no.	331-7AF70
Certifications	
UL certification	yes
KC certification	-

Additional Technical data

Order number	331-7AF70
Suppression of interference, Limits of error	
Noise suppression for $f=nx$ ($f1\pm1\%$) ($f1$ =Interference frequency, $n=1,2,\dots$) - Common-mode interference ($U_{CM}<?V$)	($U_{CM}<20V$) >80dB
Crosstalk between the inputs	>50dB
Temperature error (reference to the input range)	$\pm 0.0150\%/K$
Linearity error (with reference to the input range)	$\pm 0.02\%$
Repeatability (in steady state at 25°C, reference to the input range)	$\pm 0.05\%$
Data for selecting a sensor	
Maximum input current for current input (destruction limit)	max. 40mA
Connection of the sensor - for measuring current 2-wire transmitter	possible

6.11 331-7BF70 - AI 8x16Bit U**Properties**

The analog input modules transform analog signals from the process into digital signals for the internal processing. The modules are preset to one measuring range.

- 8 inputs
- Oscilloscope-/FIFO-Function parameterizable
- The 8 inputs are read synchronous
- Measuring value resolution 15bit + sign
- Suitable for sensors $\pm 10V$
- Parameterizable diagnostic and process interrupt
- Isolated to the backplane bus and between the channels

Default settings

After PowerON the diagnostics function of every channel is deactivated.

331-7BF70 - AI 8x16Bit U

Structure

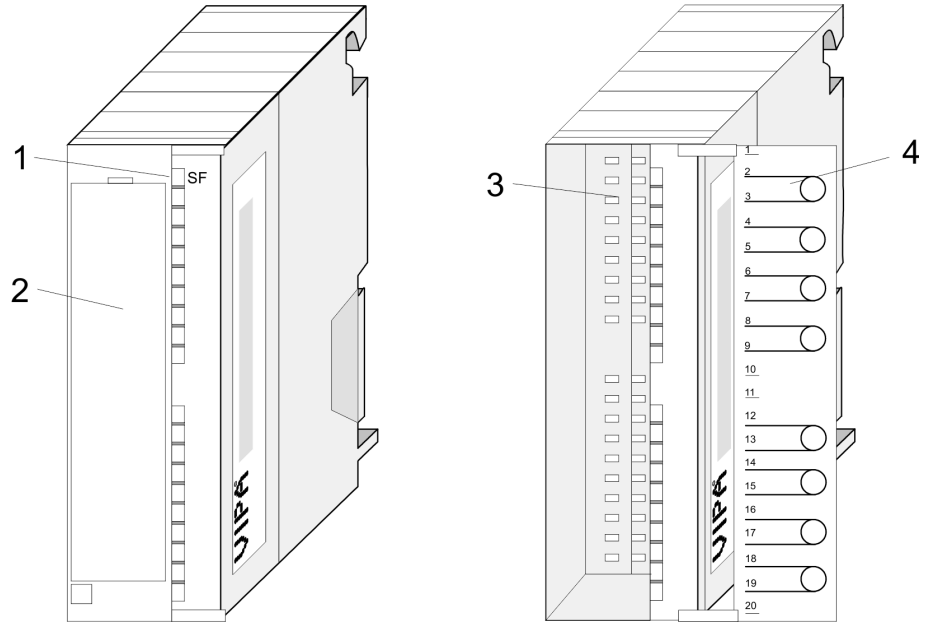

- 1 LEDs
- 2 flap with labeling strip
- 3 contact bar
- 4 flap opened with inner label

Pin assignment/LED

Pin	Assignment	Connection	331-7BF70	LED	Description
1	Power supply DC 24V	1 — L+		SF	LED (red) Group error, ON as soon as a diagnostic entry is present
2	+ Channel 0	2 —			
3	Ground Channel 0	3 —			
4	+ Channel 1	4 —			
5	Ground Channel 1	5 —			
6	+ Channel 2	6 —			
7	Ground Channel 2	7 —			
8	+ Channel 3	8 —			
9	Ground Channel 3	9 —			
10	n.c.	10 —			
11	n.c.	11 —			
12	+ Channel 4	12 —			
13	Ground Channel 4	13 —			
14	+ Channel 5	14 —			
15	Ground Channel 5	15 —			
16	+ Channel 6	16 —			
17	Ground Channel 6	17 —			
18	+Channel 7	18 —			
19	Ground Channel 7	19 —			
20	Power supply Ground	20 — M			

CAUTION! Please regard that the modules described here do not have hardware precautions against wrong wiring. The modules are fix preset to one measuring range. For example, the modules may get a defect if you connect a voltage at current measuring module.

6.11.1 Technical data

Order no.	331-7BF70
Type	SM 331S - SPEED-Bus
SPEED-Bus	✓

Order no.	331-7BF70
Current consumption/power loss	
Current consumption from backplane bus	530 mA
Power loss	4 W
Technical data analog inputs	
Number of inputs	8
Cable length, shielded	50 m
Rated load voltage	DC 24 V
Current consumption from load voltage L+ (without load)	62 mA
Voltage inputs	✓
Min. input resistance (voltage range)	120 kΩ
Input voltage ranges	-10 V ... +10 V
Operational limit of voltage ranges	+/-0.6%
Operational limit of voltage ranges with SFU	-
Basic error limit voltage ranges	+/-0.4%
Basic error limit voltage ranges with SFU	-
Destruction limit voltage	max. 30V
Current inputs	-
Max. input resistance (current range)	-
Input current ranges	-
Operational limit of current ranges	-
Operational limit of current ranges with SFU	-
Grundfehlergrenze Strombereiche	-
Radical error limit current ranges with SFU	-
Destruction limit current inputs (electrical current)	-
Destruction limit current inputs (voltage)	-
Resistance inputs	-
Resistance ranges	-
Operational limit of resistor ranges	-
Operational limit of resistor ranges with SFU	-
Basic error limit	-
Basic error limit with SFU	-
Destruction limit resistance inputs	-
Resistance thermometer inputs	-

Order no.	331-7BF70
Resistance thermometer ranges	-
Operational limit of resistance thermometer ranges	-
Operational limit of resistance thermometer ranges with SFU	-
Basic error limit thermoresistor ranges	-
Basic error limit thermoresistor ranges with SFU	-
Destruction limit resistance thermometer inputs	-
Thermocouple inputs	-
Thermocouple ranges	-
Operational limit of thermocouple ranges	-
Operational limit of thermocouple ranges with SFU	-
Basic error limit thermoelement ranges	-
Basic error limit thermoelement ranges with SFU	-
Destruction limit thermocouple inputs	-
Programmable temperature compensation	-
External temperature compensation	-
Internal temperature compensation	-
Temperature error internal compensation	-
Technical unit of temperature measurement	-
Resolution in bit	16
Measurement principle	successive approximation
Basic conversion time	25 µs all channels
Noise suppression for frequency	-
Initial data size	16 Byte
Status information, alarms, diagnostics	
Status display	none
Interrupts	yes
Process alarm	yes, parameterizable
Diagnostic interrupt	yes, parameterizable
Diagnostic functions	yes
Diagnostics information read-out	possible
Supply voltage display	none

Order no.	331-7BF70
Group error display	red SF LED
Channel error display	none
Isolation	
Between channels	✓
Between channels of groups to	1
Between channels and backplane bus	✓
Between channels and power supply	✓
Max. potential difference between circuits	-
Max. potential difference between inputs (Ucm)	DC 30 V
Max. potential difference between Mana and Mintern (Uiso)	-
Max. potential difference between inputs and Mana (Ucm)	-
Max. potential difference between inputs and Mintern (Uiso)	DC 75 V/ AC 50 V
Max. potential difference between Mintern and outputs	-
Insulation tested with	DC 500 V
Datasizes	
Input bytes	16
Output bytes	0
Parameter bytes	41
Diagnostic bytes	16
Housing	
Material	PPE
Mounting	DIN rail SPEED-Bus
Mechanical data	
Dimensions (WxHxD)	40 mm x 125 mm x 120 mm
Weight	210 g
Environmental conditions	
Operating temperature	0 °C to 60 °C
Storage temperature	-25 °C to 70 °C
Certifications	
UL certification	yes
KC certification	-

Additional Technical data

Order number	331-7BF70
Suppression of interference, Limits of error	
Noise suppression for $f=nx$ ($f1\pm1\%$) ($f1$ =Interference frequency, $n=1,2,\dots$) - Common-mode interference ($U_{CM}< ?V$)	($U_{CM}<20V$) >80dB
Crosstalk between the inputs	>50dB
Temperature error (reference to the input range)	$\pm 0.0150\%/K$
Linearity error (with reference to the input range)	$\pm 0.02\%$
Repeatability (in steady state at 25°C, reference to the input range)	$\pm 0.05\%$
Data for selecting a sensor	
Maximum input current for current input (destruction limit)	-
Maximum input voltage for voltage input (destruction limit)	max. 30V
Connection of the sensor - for measuring voltage	possible