

# System 300S

CP | 342-1DA70 | Manual

HB140 | CP | 342-1DA70 | en | 17-23

SPEED7 CP 342S-DP



VIPA USA, INC  
980 Birmingham Rd. Ste 721  
Alpharetta, GA 30004 USA

Tel.: +1 (678) 880-6910  
Email: [info@vipausa.com](mailto:info@vipausa.com)  
Internet: [www.vipausa.com](http://www.vipausa.com)

## Table of contents

<b>1</b>	<b>General</b> .....	<b>4</b>
1.1	Copyright © YASKAWA Europe GmbH.....	4
1.2	About this manual.....	5
1.3	Safety information.....	6
<b>2</b>	<b>Basics</b> .....	<b>7</b>
2.1	Safety information for users.....	7
2.2	Hints for the project engineering.....	8
2.3	General data.....	11
2.3.1	Use in difficult operating conditions.....	12
<b>3</b>	<b>Assembly and installation guidelines</b> .....	<b>13</b>
3.1	Overview.....	13
3.2	Installation dimensions.....	14
3.3	Assembly SPEED-Bus.....	15
3.4	Installation guidelines.....	19
<b>4</b>	<b>Hardware description</b> .....	<b>21</b>
4.1	Properties.....	21
4.2	Structure .....	22
4.3	Technical data.....	25
<b>5</b>	<b>Deployment</b> .....	<b>27</b>
5.1	Basics PROFIBUS.....	27
5.2	Addressing at SPEED-Bus.....	28
5.3	Project engineering .....	29
5.3.1	Fast introduction .....	29
5.3.2	Steps of the project engineering .....	29
5.3.3	Project engineering slave.....	34
5.4	FC/SFC 194 - DP_EXCH - Data exchange with CP342S.....	37
5.5	PROFIBUS installation guidelines.....	39

# 1 General

## 1.1 Copyright © YASKAWA Europe GmbH

### All Rights Reserved

This document contains proprietary information of Yaskawa and is not to be disclosed or used except in accordance with applicable agreements.

This material is protected by copyright laws. It may not be reproduced, distributed, or altered in any fashion by any entity (either internal or external to Yaskawa) except in accordance with applicable agreements, contracts or licensing, without the express written consent of Yaskawa and the business management owner of the material.

For permission to reproduce or distribute, please contact: YASKAWA Europe GmbH, European Headquarters, Hauptstraße 185, 65760 Eschborn, Germany

Tel.: +49 6196 569 300

Fax.: +49 6196 569 398

Email: [info@yaskawa.eu.com](mailto:info@yaskawa.eu.com)

Internet: [www.yaskawa.eu.com](http://www.yaskawa.eu.com)



*Every effort has been made to ensure that the information contained in this document was complete and accurate at the time of publishing. Nevertheless, the authors retain the right to modify the information.*

*This customer document describes all the hardware units and functions known at the present time. Descriptions may be included for units which are not present at the customer site. The exact scope of delivery is described in the respective purchase contract.*

### EC conformity declaration

Hereby, YASKAWA Europe GmbH declares that the products and systems are in compliance with the essential requirements and other relevant provisions. Conformity is indicated by the CE marking affixed to the product.

### Conformity Information

For more information regarding CE marking and Declaration of Conformity (DoC), please contact your local representative of YASKAWA Europe GmbH.

### Trademarks

VIPA, SLIO, System 100V, System 200V, System 300V, System 300S, System 400V, System 500S and Commander Compact are registered trademarks of YASKAWA Europe GmbH.

SPEED7 is a registered trademark of YASKAWA Europe GmbH.

SIMATIC, STEP, SINEC, TIA Portal, S7-300, S7-400 and S7-1500 are registered trademarks of Siemens AG.

Microsoft and Windows are registered trademarks of Microsoft Inc., USA.

Portable Document Format (PDF) and Postscript are registered trademarks of Adobe Systems, Inc.

All other trademarks, logos and service or product marks specified herein are owned by their respective companies.

### Document support

Contact your local representative of YASKAWA Europe GmbH if you have errors or questions regarding the content of this document. You can reach YASKAWA Europe GmbH via the following contact:

Email: [Documentation.HER@yaskawa.eu.com](mailto:Documentation.HER@yaskawa.eu.com)

**Technical support**

Contact your local representative of YASKAWA Europe GmbH if you encounter problems or have questions regarding the product. If such a location is not available, you can reach the Yaskawa customer service via the following contact:

YASKAWA Europe GmbH,  
European Headquarters, Hauptstraße 185, 65760 Eschborn, Germany  
Tel.: +49 6196 569 500 (hotline)  
Email: support@yaskawa.eu.com

## 1.2 About this manual

**Objective and contents**

This manual describes the CP 342-1DA70 of the System 300S from Yaskawa. It contains a description of the construction, project implementation and usage.

Product	Order number	as of state:	
		CP-HW	CP-FW
CP 342S-DP	342-1DA70	02	V3.1.4

**Target audience**

The manual is targeted at users who have a background in automation technology.

**Structure of the manual**

The manual consists of chapters. Every chapter provides a self-contained description of a specific topic.

**Guide to the document**

The following guides are available in the manual:

- An overall table of contents at the beginning of the manual
- References with page numbers

**Availability**

The manual is available in:

- printed form, on paper
- in electronic form as PDF-file (Adobe Acrobat Reader)

**Icons Headings**

Important passages in the text are highlighted by following icons and headings:

**DANGER!**

Immediate or likely danger. Personal injury is possible.

**CAUTION!**

Damages to property is likely if these warnings are not heeded.



*Supplementary information and useful tips.*

### 1.3 Safety information

#### Applications conforming with specifications

The system is constructed and produced for:

- communication and process control
- general control and automation tasks
- industrial applications
- operation within the environmental conditions specified in the technical data
- installation into a cubicle



#### **DANGER!**

This device is not certified for applications in

- in explosive environments (EX-zone)

#### Documentation

The manual must be available to all personnel in the

- project design department
- installation department
- commissioning
- operation



#### **CAUTION!**

**The following conditions must be met before using or commissioning the components described in this manual:**

- Hardware modifications to the process control system should only be carried out when the system has been disconnected from power!
- Installation and hardware modifications only by properly trained personnel.
- The national rules and regulations of the respective country must be satisfied (installation, safety, EMC ...)

#### Disposal

**National rules and regulations apply to the disposal of the unit!**

## 2 Basics

### 2.1 Safety information for users

#### Handling of electrostatic sensitive modules

The modules make use of highly integrated components in MOS-Technology. These components are extremely sensitive to over-voltages that can occur during electrostatic discharges. The following symbol is attached to modules that can be destroyed by electrostatic discharges.



The Symbol is located on the module, the module rack or on packing material and it indicates the presence of electrostatic sensitive equipment. It is possible that electrostatic sensitive equipment is destroyed by energies and voltages that are far less than the human threshold of perception. These voltages can occur where persons do not discharge themselves before handling electrostatic sensitive modules and they can damage components thereby, causing the module to become inoperable or unusable. Modules that have been damaged by electrostatic discharges can fail after a temperature change, mechanical shock or changes in the electrical load. Only the consequent implementation of protection devices and meticulous attention to the applicable rules and regulations for handling the respective equipment can prevent failures of electrostatic sensitive modules.

#### Shipping of modules

Modules must be shipped in the original packing material.

#### Measurements and alterations on electrostatic sensitive modules

When you are conducting measurements on electrostatic sensitive modules you should take the following precautions:

- Floating instruments must be discharged before use.
- Instruments must be grounded.

Modifying electrostatic sensitive modules you should only use soldering irons with grounded tips.



#### CAUTION!

Personnel and instruments should be grounded when working on electrostatic sensitive modules.

## 2.2 Hints for the project engineering

### Overview

For the project engineering of a SPEED7 system please follow this approach:

- Project engineering of the SPEED7-CPU and the internal DP master (if existing)
- Project engineering of the real plugged modules at the standard bus
- Project engineering of the internal Ethernet PG/OP channel after the real plugged modules as virtual CP 343-1 (Setting of IP address, subnet mask and gateway for online project engineering)
- Project engineering of an internal CP343 (if existing) as 2. CP 343-1
- Project engineering and connection of the SPEED-Bus-CPs res. -DP master as CP 343-1 (343-1EX11) res. CP 342-5 (342-5DA02 V5.0)
- Project engineering of all SPEED-Bus modules as single DP slaves in a virtual DP master module (SPEEDBUS.GSD required)



*Please do always use the corresponding CPU from Siemens in the hardware catalog to configure a CPU 31xS from Yaskawa. For the project engineering, a thorough knowledge of the SIMATIC manager and the hardware configurator from Siemens is required!*

### Requirements

The hardware configurator is part of the Siemens SIMATIC manager. It serves the project engineering. Please look at the hardware catalog for the modules that may be configured. For the deployment of the System 300S modules at the SPEED-Bus the inclusion of the System 300S modules into the hardware catalog via the GSD-file SPEEDBUS.GSD from Yaskawa is necessary.



## Approach

### Standard bus

Slot	Module
1	
2	CPU ...
X...	...
X...	...
3	

real modules  
at the standard bus

343-1EX11 (PG/OP)

343-1EX11 (only CPU 31xSN)

CPs res. DP master  
at the SPEED-Bus as  
343-1EX11 res. 342-5DA02

342-5DA02 V5.0

virtual DP master for CPU  
and all SPEED-Bus modules

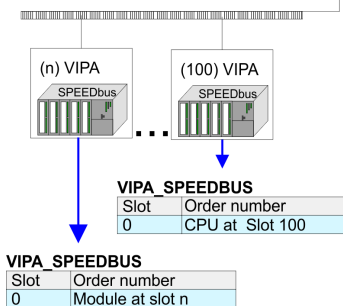

The project engineering of the SPEED7-CPU has the following components: To be compatible with the Siemens SIMATIC manager, the following steps are required:

#### 1. Preparation

Start the hardware configurator from Siemens and include the SPEEDBUS.GSD for the SPEED-Bus from Yaskawa.

#### 2. Project engineering of the CPU

Project the corresponding CPU. If your SPEED7-CPU contains a DP master, you may now connect it with PROFIBUS and configure your DP slaves.

#### 3. Project engineering of the real plugged modules at the standard bus

Set the modules that are at the right side of the CPU at the standard bus starting with slot 4.

#### 4. Project engineering of the integrated CPs

For the internal Ethernet PG/OP channel you have to set a CP 343-1 (343-1EX11) as 1. module at the real plugged modules. If your SPEED7-CPU has additionally an integrated CP 343, this is also configured as CP 343-1 but always below the former placed CP 343-1.

#### 5. Project engineering of the SPEED-Bus-CPs and -DP master

Plug and connect all CPs as 343-1EX11 and DP master as 342-5DA02 V5.0 at the SPEED-Bus below the former configured internal CPU components.



Please regard that the sequence within a function group (CP res. DP master) corresponds the sequence at the SPEED-Bus from right to left.

#### 6. Project engineering of the CPU and all SPEED-Bus modules in a virtual master system

The slot assignment of the SPEED-Bus modules and the parameterization of the in-/output periphery happens via a virtual PROFIBUS DP master system. For this, place a DP master (342-5DA02 V5.0) with master system as last module. The PROFIBUS address must be < 100! Now include the slave "VIPA\_SPEEDBUS" for the CPU and every module at the SPEED-Bus. After the installation of the SPEEDBUS.GSD you may find this under *Profibus-DP / Additional field devices / I/O / VIPA\_SPEEDBUS*. Set the slot number of the module (100...110) as PROFIBUS address and plug the according module at slot 0 of the slave system.

### Bus extension with IM 360 and IM 361

To extend the bus you may use the IM 360 from Siemens, where 3 further extensions racks can be connected via the IM 361. Bus extensions must be placed at slot 3. More detailed information is to be found in the chapter "Deployment CPU 31xS" at "Addressing".

Summary

The following illustration summarizes all project engineering steps:

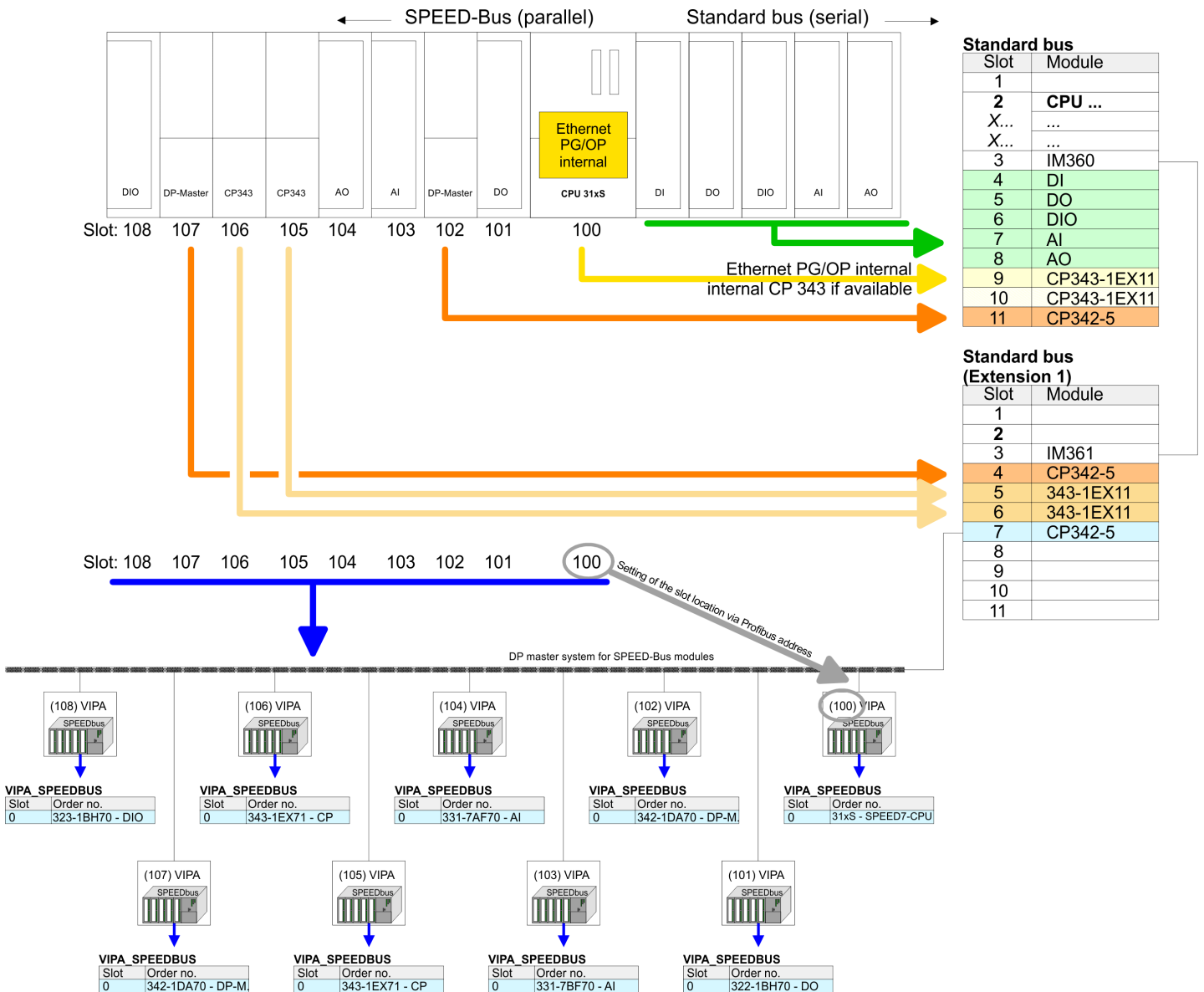

The according module is to be taken over from the HW catalog of VIPA\_SPEEDBUS on slot 0.

**i** The sequence of the DPM and CP function groups is insignificant. You only have to take care to regard the sequence within a function group (DP1, DP2... res. CP1, CP2 ...).

**i** **Hint, valid for all SPEED-Bus modules!**  
 The SPEED-Bus always requires the Siemens DP master CP 342-5 (342-5DA02 V5.0) as last module to be included, connected and parameterized to the operation mode DP master. Every SPEED-Bus module has to be connected as VIPA\_SPEED-Bus slave into this master system. By setting the SPEED-Bus slot number via the PROFIBUS address and by including the according SPEED-Bus module at slot 0, the SIMATIC manager receives information about the modules at the SPEED-Bus.

## 2.3 General data

### Conformity and approval

Conformity		
CE	2014/35/EU	Low-voltage directive
	2014/30/EU	EMC directive
Approval		
UL		Refer to Technical data
others		
RoHS	2011/65/EU	Restriction of the use of certain hazardous substances in electrical and electronic equipment

### Protection of persons and device protection

Type of protection	-	IP20
Electrical isolation		
to the field bus	-	electrically isolated
to the process level	-	electrically isolated
Insulation resistance		-
Insulation voltage to reference earth		
Inputs / outputs	-	AC / DC 50V, test voltage AC 500V
Protective measures	-	against short circuit

### Environmental conditions to EN 61131-2

Climatic		
Storage / transport	EN 60068-2-14	-25...+70°C
Operation		
Horizontal installation hanging	EN 61131-2	0...+60°C
Horizontal installation lying	EN 61131-2	0...+55°C
Vertical installation	EN 61131-2	0...+50°C
Air humidity	EN 60068-2-30	RH1 (without condensation, rel. humidity 10...95%)
Pollution	EN 61131-2	Degree of pollution 2
Installation altitude max.	-	2000m
Mechanical		
Oscillation	EN 60068-2-6	1g, 9Hz ... 150Hz
Shock	EN 60068-2-27	15g, 11ms

General data > Use in difficult operating conditions

### Mounting conditions

Mounting place	-	In the control cabinet
Mounting position	-	Horizontal and vertical

EMC	Standard	Comment
Emitted interference	EN 61000-6-4	Class A (Industrial area)
Noise immunity zone B	EN 61000-6-2	Industrial area
	EN 61000-4-2	ESD 8kV at air discharge (degree of severity 3), 4kV at contact discharge (degree of severity 2)
	EN 61000-4-3	HF field immunity (casing) 80MHz ... 1000MHz, 10V/m, 80% AM (1kHz) 1.4GHz ... 2.0GHz, 3V/m, 80% AM (1kHz) 2GHz ... 2.7GHz, 1V/m, 80% AM (1kHz)
	EN 61000-4-6	HF conducted 150kHz ... 80MHz, 10V, 80% AM (1kHz)
	EN 61000-4-4	Burst, degree of severity 3
	EN 61000-4-5	Surge, degree of severity 3 *

\*) Due to the high-energetic single pulses with Surge an appropriate external protective circuit with lightning protection elements like conductors for lightning and overvoltage is necessary.

### 2.3.1 Use in difficult operating conditions



*Without additional protective measures, the products must not be used in locations with difficult operating conditions; e.g. due to:*

- *dust generation*
- *chemically active substances (corrosive vapors or gases)*
- *strong electric or magnetic fields*

## 3 Assembly and installation guidelines

### 3.1 Overview

#### SPEED-Bus

- The SPEED-Bus is a 32bit parallel bus developed from Yaskawa.
- Via the SPEED-Bus you may connect up to 10 SPEED-Bus modules to your CPU.
- In opposite to the "standard" backplane bus where the modules are plugged-in at the right side of the CPU by means of single bus connectors, the modules at the SPEED-Bus are plugged-in at the left side of the CPU via a special SPEED-Bus rail.
- Yaskawa delivers profile rails with integrated SPEED-Bus for 2, 6, or 10 SPEED-Bus peripheral modules with different lengths.
- Each SPEED-Bus rail has a slot for an external power supply. This allows you to raise the maximum current at the back plane bus. Only the "SLOT1 DCDC" allows you to plug-in either a SPEED-Bus module or an additional power supply (307-1FB70).

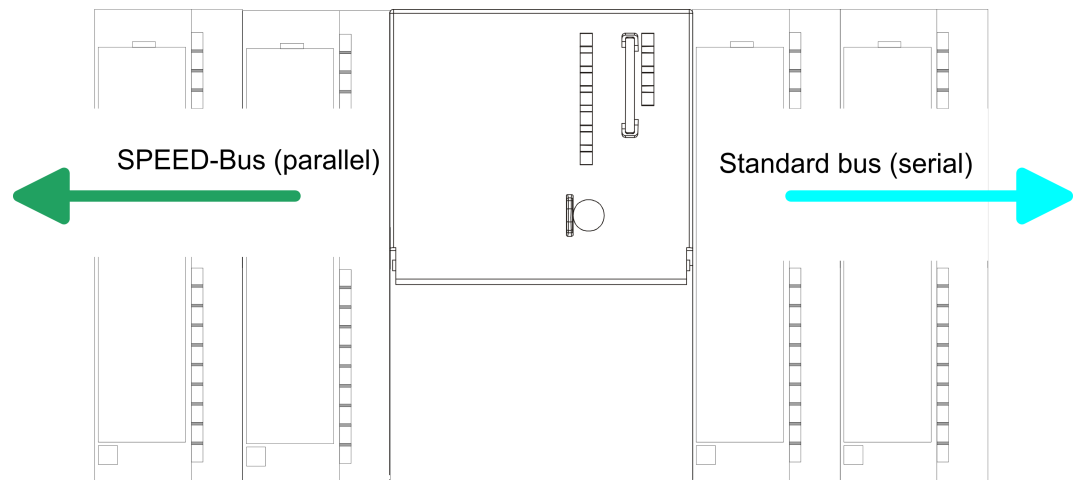

#### SPEED-Bus peripheral modules

The SPEED-Bus peripheral modules may exclusively plugged at the SPEED-Bus slots at the left side of the CPU. The following SPEED-Bus modules are in preparation:

- Fast fieldbus modules like PROFIBUS DP, Interbus, CANopen master and CANopen slave
- Fast CP 343 (CP 343 Communication processor for Ethernet)
- Fast CP 341 with double RS 422/485 interface
- Fast digital input-/output modules (Fast Digital IN/OUT)

#### Serial Standard bus

The single modules are directly installed on a profile rail and connected via the backplane bus coupler. Before installing the modules you have to clip the backplane bus coupler to the module from the backside. The backplane bus couplers are included in the delivery of the peripheral modules.

#### Parallel SPEED-Bus

With SPEED-Bus the bus connection happens via a SPEED-Bus rail integrated in the profile rail at the left side of the CPU. Due to the parallel SPEED-Bus not all slots must be occupied in sequence.

#### SLOT 1 for additional power supply

At slot (SLOT 1 DCDC) you may plug either a SPEED-Bus module or an additional power supply.

Installation dimensions

**Assembly possibilities**

You may assemble the System 300 horizontally, vertically or lying. Please regard the allowed environment temperatures:

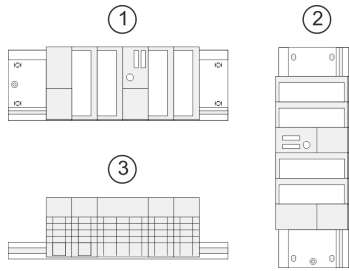

- 1 horizontal assembly: from 0 to 60°C
- 2 vertical assembly: from 0 to 50°C
- 3 lying assembly: from 0 to 55°C

**3.2 Installation dimensions**

**Dimensions Basic enclosure**

1tier width (WxHxD) in mm: 40 x 125 x 120

**Dimensions**

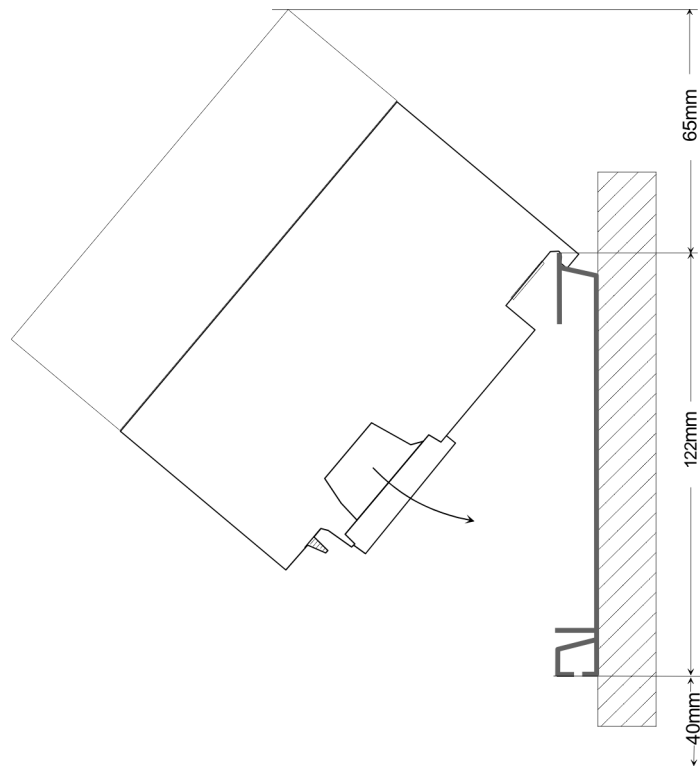

**Installation dimensions**

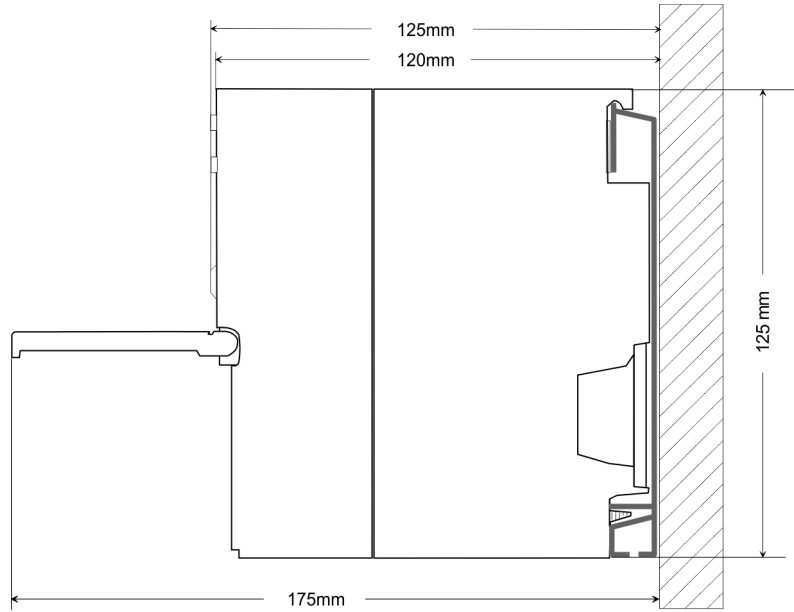

**3.3 Assembly SPEED-Bus**

**Pre-manufactured SPEED-Bus profile rail**

For the deployment of SPEED-Bus modules, a pre-manufactured SPEED-Bus rail is required. This is available mounted on a profile rail with 2, 6 or 10 extension slots.

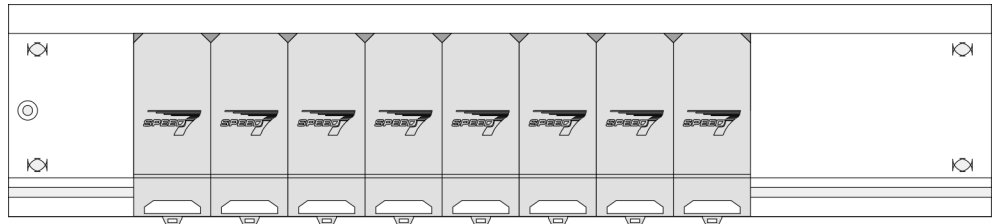

**Dimensions**

Order number	Number of modules SPEED-Bus/Standard bus	A	B	C	D	E
391-1AF10	2/6	530	100	268	510	10
391-1AF30	6/2	530	100	105	510	10
391-1AF50	10/0	530	20	20	510	10
391-1AJ10	2/15	830	22	645	800	15
391-1AJ30	6/11	830	22	480	800	15
391-1AJ50	10/7	830	22	320	800	15

Measures in mm

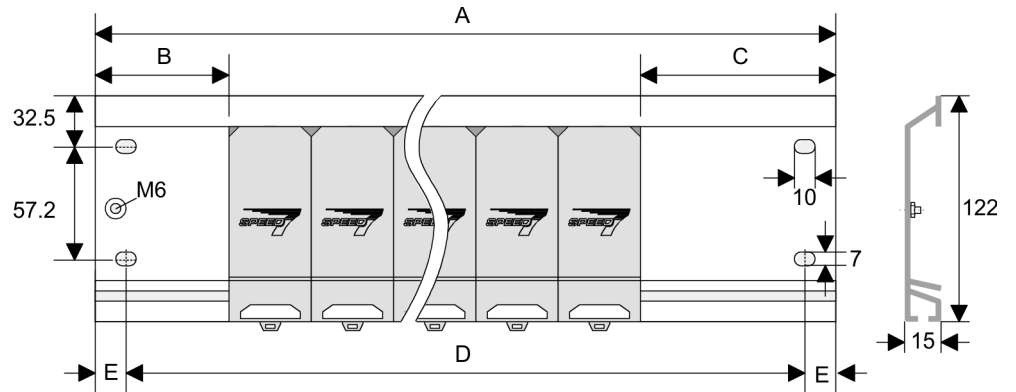

**Installation of the profile rail**

1. Bolt the profile rail with the background (screw size: M6), so that you still have minimum 65mm space above and 40mm below the profile rail. Please look for a low-impedance connection between profile rail and background.

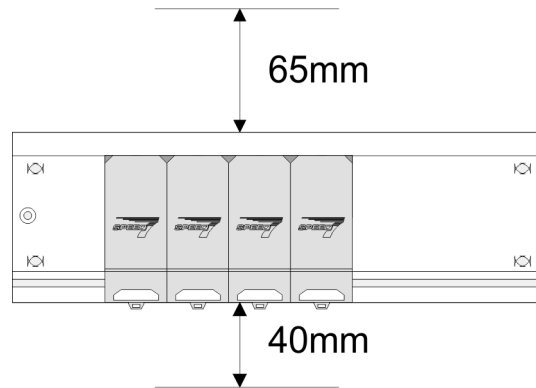

2. Connect the profile rail with the protected earth conductor. The minimum cross-section of the cable to the protected earth conductor has to be 10mm<sup>2</sup>.

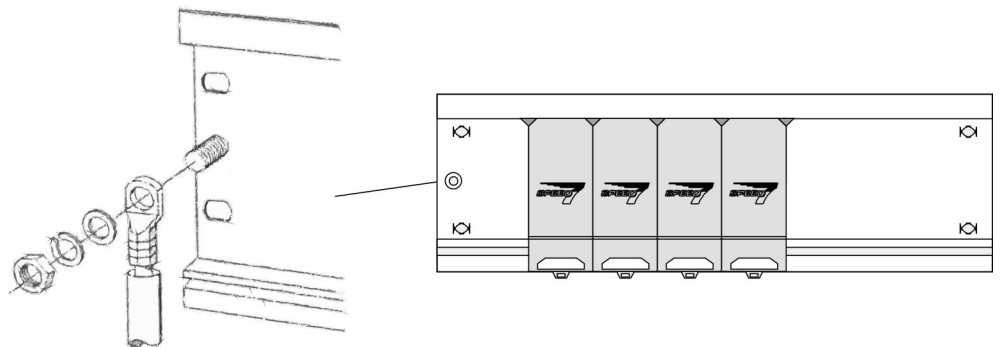



**Installation SPEED-Bus module**

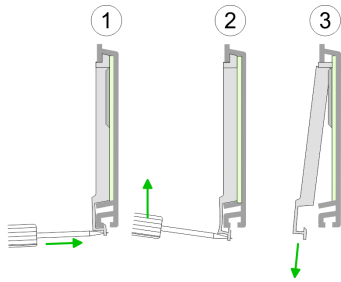

1. ➤ Dismantle the according protection flaps of the SPEED-Bus slot with a screw driver (open and pull down).

For the SPEED-Bus is a parallel bus, not every SPEED-Bus slot must be used in series. Leave the protection flap installed at an unused SPEED-Bus slot.

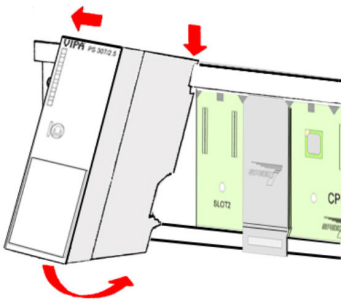

2. ➤ At deployment of a DC 24V power supply, install it at the shown position at the profile rail at the left side of the SPEED-Bus and push it to the left to the isolation bolt of the profile rail.
3. ➤ Fix the power supply by screwing.

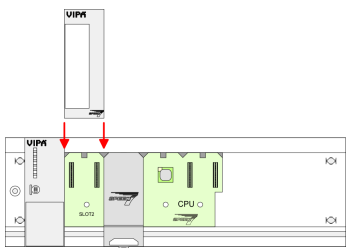

4. ➤ To connect the SPEED-Bus modules, plug it between the triangular positioning helps to a slot marked with "SLOT ..." and pull it down.
5. ➤ Only the "SLOT1 DCDC" allows you to plug-in either a SPEED-Bus module or an additional power supply.
6. ➤ Fix the CPU by screwing.

**Installation CPU without Standard-Bus-Modules**

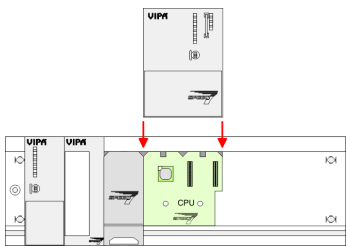

1. ➤ To deploy the SPEED7-CPU exclusively at the SPEED-Bus, plug it between the triangular positioning helps to the slot marked with "CPU SPEED7" and pull it down.

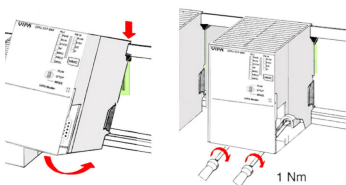

2. ➤ Fix the CPU by screwing.

Assembly SPEED-Bus

**Installation CPU with Standard-Bus-Modules**

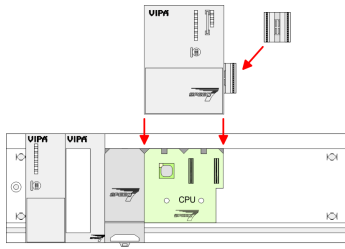

1. ➔ If also standard modules shall be plugged, take a bus coupler and click it at the CPU from behind like shown in the picture. Plug the CPU between the triangular positioning helps to the slot marked with "CPU SPEED7" and pull it down.

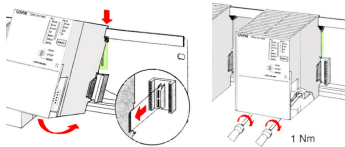

2. ➔ Fix the CPU by screwing.

**Installation Standard-Bus-Modules**

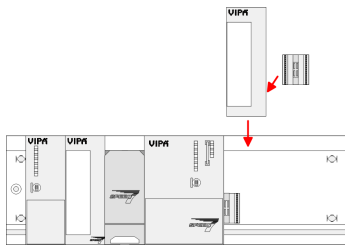

- ➔ Repeat this procedure with the peripheral modules, by clicking a backplane bus coupler, stick the module right from the modules you've already fixed, click it downwards and connect it with the backplane bus coupler of the last module and bolt it.



**CAUTION!**

- The power supplies must be released before installation and repair tasks, i.e. before handling with the power supply or with the cabling you must disconnect current/voltage (pull plug, at fixed connection switch off the concerning fuse)!
- Installation and modifications only by properly trained personnel!

## 3.4 Installation guidelines

<b>General</b>	<p>The installation guidelines contain information about the interference free deployment of a PLC system. There is the description of the ways, interference may occur in your PLC, how you can make sure the electromagnetic compatibility (EMC), and how you manage the isolation.</p>
<b>What does EMC mean?</b>	<p>Electromagnetic compatibility (EMC) means the ability of an electrical device, to function error free in an electromagnetic environment without being interfered respectively without interfering the environment.</p> <p>The components of Yaskawa are developed for the deployment in industrial environments and meets high demands on the EMC. Nevertheless you should project an EMC planning before installing the components and take conceivable interference causes into account.</p>
<b>Possible interference causes</b>	<p>Electromagnetic interferences may interfere your control via different ways:</p> <ul style="list-style-type: none"><li>■ Electromagnetic fields (RF coupling)</li><li>■ Magnetic fields with power frequency</li><li>■ Bus system</li><li>■ Power supply</li><li>■ Protected earth conductor</li></ul> <p>Depending on the spreading medium (lead bound or lead free) and the distance to the interference cause, interferences to your control occur by means of different coupling mechanisms.</p> <p>There are:</p> <ul style="list-style-type: none"><li>■ galvanic coupling</li><li>■ capacitive coupling</li><li>■ inductive coupling</li><li>■ radiant coupling</li></ul>
<b>Basic rules for EMC</b>	<p>In the most times it is enough to take care of some elementary rules to guarantee the EMC. Please regard the following basic rules when installing your PLC.</p> <ul style="list-style-type: none"><li>■ Take care of a correct area-wide grounding of the inactive metal parts when installing your components.<ul style="list-style-type: none"><li>– Install a central connection between the ground and the protected earth conductor system.</li><li>– Connect all inactive metal extensive and impedance-low.</li><li>– Please try not to use aluminium parts. Aluminium is easily oxidizing and is therefore less suitable for grounding.</li></ul></li><li>■ When cabling, take care of the correct line routing.<ul style="list-style-type: none"><li>– Organize your cabling in line groups (high voltage, current supply, signal and data lines).</li><li>– Always lay your high voltage lines and signal respectively data lines in separate channels or bundles.</li><li>– Route the signal and data lines as near as possible beside ground areas (e.g. suspension bars, metal rails, tin cabinet).</li></ul></li></ul>

- Proof the correct fixing of the lead isolation.
  - Data lines must be shielded.
  - Analog lines must be shielded. When transmitting signals with small amplitudes the one sided laying of the isolation may be favourable.
  - Cables for frequency inverters, servo and stepper motors must be shielded.
  - Lay the line isolation extensively on an isolation/protected earth conductor rail directly after the cabinet entry and fix the isolation with cable clamps.
  - Make sure that the isolation/protected earth conductor rail is connected impedance-low with the cabinet.
  - Use metallic or metallised plug cases for isolated data lines.
- In special use cases you should appoint special EMC actions.
  - Consider to wire all inductivities with erase links.
  - Please consider luminescent lamps can influence signal lines.
- Create a homogeneous reference potential and ground all electrical operating supplies when possible.
  - Please take care for the targeted employment of the grounding actions. The grounding of the PLC serves for protection and functionality activity.
  - Connect installation parts and cabinets with your PLC in star topology with the isolation/protected earth conductor system. So you avoid ground loops.
  - If there are potential differences between installation parts and cabinets, lay sufficiently dimensioned potential compensation lines.

**Isolation of conductors**

Electrical, magnetically and electromagnetic interference fields are weakened by means of an isolation, one talks of absorption. Via the isolation rail, that is connected conductive with the rack, interference currents are shunt via cable isolation to the ground. Here you have to make sure, that the connection to the protected earth conductor is impedance-low, because otherwise the interference currents may appear as interference cause.

When isolating cables you have to regard the following:

- If possible, use only cables with isolation tangle.
- The hiding power of the isolation should be higher than 80%.
- Normally you should always lay the isolation of cables on both sides. Only by means of the both-sided connection of the isolation you achieve high quality interference suppression in the higher frequency area. Only as exception you may also lay the isolation one-sided. Then you only achieve the absorption of the lower frequencies. A one-sided isolation connection may be convenient, if:
  - the conduction of a potential compensating line is not possible.
  - analog signals (some mV respectively  $\mu$ A) are transferred.
  - foil isolations (static isolations) are used.
- With data lines always use metallic or metallised plugs for serial couplings. Fix the isolation of the data line at the plug rack. Do not lay the isolation on the PIN 1 of the plug bar!
- At stationary operation it is convenient to strip the insulated cable interruption free and lay it on the isolation/protected earth conductor line.
- To fix the isolation tangles use cable clamps out of metal. The clamps must clasp the isolation extensively and have well contact.
- Lay the isolation on an isolation rail directly after the entry of the cable in the cabinet. Lead the isolation further on to your PLC and don't lay it on there again!



**CAUTION!**

**Please regard at installation!**

At potential differences between the grounding points, there may be a compensation current via the isolation connected at both sides.

Remedy: Potential compensation line

## 4 Hardware description

### 4.1 Properties

#### CP 342-1DA70

The CP 342S-DP may only be used at the SPEED-Bus.

- PROFIBUS DP master (Class 1) for SPEED-Bus
- Project engineering by Siemens SIMATIC Manager
- 124 DP slaves connectable
- DP-V1 (acyclic read-, write-, interrupt services), DP-V1 typical interrupt handling, 1 MSAC\_C1 with 244Byte data (4Byte DP-V1-Header + 240Byte user data)
- Diagnostic facilities

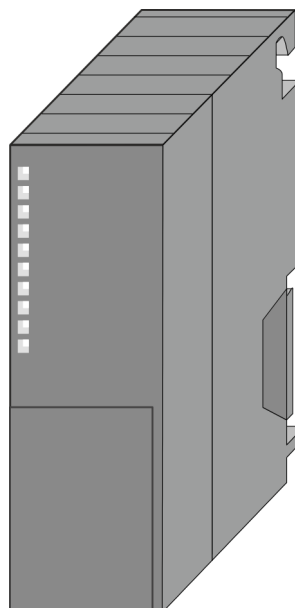

#### Order data

Type	Order No	Description
CP 342S-DP	342-1DA70	PROFIBUS DP master for SPEED-Bus

## 4.2 Structure

### CP 342-1DA70

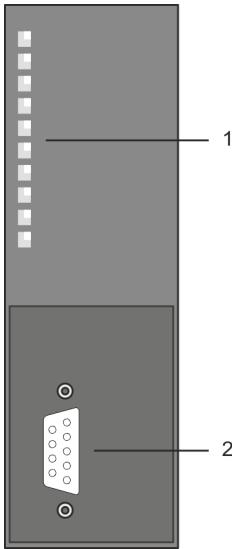

- 1 LED status indicators
- The following components are under the front flap
- 2 RS485 PROFIBUS interface

### RS485 interface

DP master  
X2

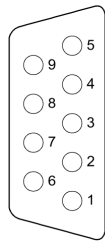

- ① shield
- ② n. c.
- ③ RxD/TxD-P (line B)
- ④ RTS
- ⑤ M5V
- ⑥ P5V
- ⑦ n. c.
- ⑧ RxD/TxD-N (line A)
- ⑨ n.c.

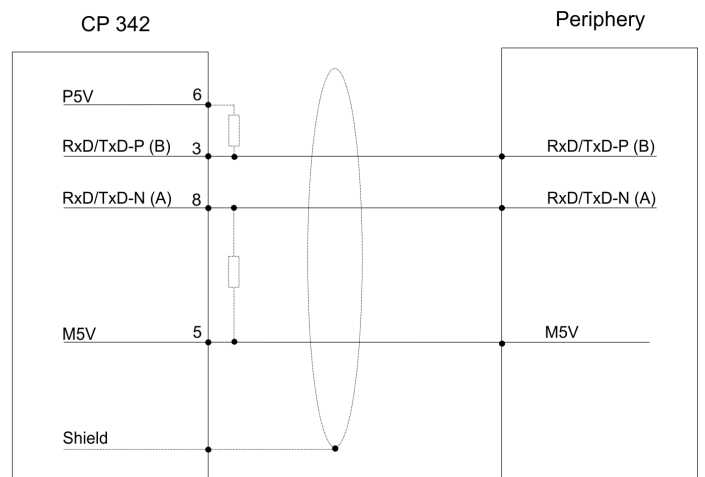

### Bus termination



*Please regard to terminate the bus at its ends by means of a terminating resistor!*

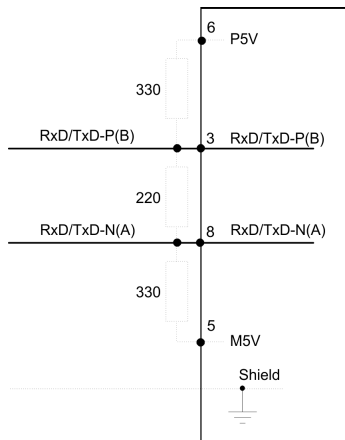





### Power supply

The CP 342-1DA70 gets its power supply via the SPEED-Bus.





🔗 *Chap. 4.3 'Technical data' page 25*

**LEDs** The CP 342-1DA70 carries a number of LEDs that are available for diagnostic purposes on the bus and for displaying the local status. Dependent on the mode of operation these give information according to the following pattern over the operating condition of the CP:

### Master operation

RUN  green	ERR  red	DE  green	IF  red	Description
<input type="checkbox"/>	<input type="checkbox"/>	<input type="checkbox"/>	<input type="checkbox"/>	Master has no project, this means the interface is deactivated.
<input checked="" type="checkbox"/>	<input type="checkbox"/>	<input type="checkbox"/>	<input type="checkbox"/>	Master has bus parameters and is in RUN without slaves.
<input checked="" type="checkbox"/>	<input type="checkbox"/>	<input checked="" type="checkbox"/>	<input type="checkbox"/>	Master is in "clear" state (safety state). <ul style="list-style-type: none"> <li>■ The inputs of the slaves may be read.</li> <li>■ The outputs are disabled.</li> </ul>
<input checked="" type="checkbox"/>	<input type="checkbox"/>	<input checked="" type="checkbox"/>	<input type="checkbox"/>	Master is in "operate" state, this means data exchange between master and slaves. <ul style="list-style-type: none"> <li>■ The outputs may be accessed.</li> </ul>
<input checked="" type="checkbox"/>	<input checked="" type="checkbox"/>	<input checked="" type="checkbox"/>	<input type="checkbox"/>	At least 1 slave is missing.
<input type="checkbox"/>	<input type="checkbox"/>	<input type="checkbox"/>	<input checked="" type="checkbox"/>	Initialization error at faulty parameterization.
<input type="checkbox"/>	<input checked="" type="checkbox"/>	<input type="checkbox"/>	<input checked="" type="checkbox"/>	Waiting state for start command from CPU.
flashing: <input checked="" type="checkbox"/>				

### Slave operation

RUN  green	ERR  red	DE  green	IF  red	Description
<input type="checkbox"/>	<input type="checkbox"/>	<input type="checkbox"/>	<input type="checkbox"/>	Slave has no project, this means the interface is deactivated.
<input checked="" type="checkbox"/>	<input type="checkbox"/>	<input type="checkbox"/>	<input type="checkbox"/>	Slave is without master.
<input checked="" type="checkbox"/>	<input type="checkbox"/>	<input checked="" type="checkbox"/>	<input type="checkbox"/>	Alternate flashing at configuration faults.
<input checked="" type="checkbox"/>	<input type="checkbox"/>	<input checked="" type="checkbox"/>	<input type="checkbox"/>	Slave exchanges data between master.
flashing: <input checked="" type="checkbox"/>				

**Firmware update** There is the possibility to execute a firmware update of the CP 342-1DA70 among others via the SPPED7 CPU by means of a memory card. So a firmware file may be recognized and assigned with startup, a pkg file name is reserved for each updateable component and hardware release, which begins with "px" and differs in a number with six digits. The pkg file name may be found at a label right down the front flap of the module.

**Set PROFIBUS address via project engineering** The assignment of a PROFIBUS address happens during project engineering. The address may be within the range 2 ... 124 in the course of which every address must be unique within the bus system. The address 1 is reserved due to the system. Particularly for SPEED-Bus modules the slot assignment at the SPEED-Bus happens via the PROFIBUS address of the SPEED-Bus slave.

Structure

**I/O data**

The CP 342-1DA70 may maximally process 8192byte input and 8192byte output data. Please regard that in the Siemens SIMATIC manager maximally 2159Byte for input and output data in the sum for all masters at the speed bus may be projected. Likewise regard during project engineering of several DP masters at the speed bus that the address ranges do not overlap, since this is not checked-up in the Siemens SIMATIC manager.

**Deployment**

With one PROFIBUS DP master up to 124 PROFIBUS DP slaves may be connected to the CPU. The DP master communicates with the DP slaves and links up its data areas with the address area of the CPU. At every POWER ON res. OVERALL RESET the CPU fetches the I/O mapping data from the master. If the CP 342-1DA70 does not have any parameters, the LEDs are off and the PROFIBUS interface is deactivated. If the CPU goes to STOP during operation, the master remains in RUN. Due to the BASP signal the outputs of every via DP slave connected module are disabled.

**Default bus parameters**

**Address: 2, Transfer rate: 1.5MBaud**



### 4.3 Technical data

<b>Order no.</b>	<b>342-1DA70</b>
Type	CP 342S DP, PROFIBUS-DP master SPEED-Bus
SPEED-Bus	✓
<b>Current consumption/power loss</b>	
Current consumption from backplane bus	560 mA
Power loss	2.8 W
<b>Status information, alarms, diagnostics</b>	
Status display	yes
Interrupts	no
Process alarm	no
Diagnostic interrupt	no
Diagnostic functions	no
Diagnostics information read-out	possible
Supply voltage display	none
Group error display	yes
Channel error display	none
<b>Functionality Sub-D interfaces</b>	
Type	DP
Type of interface	RS485
Connector	Sub-D, 9-pin, female
Electrically isolated	✓
MPI	-
MP <sup>2</sup> I (MPI/RS232)	-
Point-to-point interface	-
5V DC Power supply	max. 90mA, isolated
24V DC Power supply	-
<b>Sub-D interfaces</b>	
Type	-
Type of interface	-
Connector	-
Electrically isolated	-
MPI	-
MP <sup>2</sup> I (MPI/RS232)	-
Point-to-point interface	-
5V DC Power supply	-
24V DC Power supply	-

## Technical data

<b>Order no.</b>	<b>342-1DA70</b>
<b>Functionality RJ45 interfaces</b>	
Type	-
Type of interface	-
Connector	-
Electrically isolated	-
PG/OP channel	-
Number of connections, max.	-
Productive connections	-
Fieldbus	-
Type	-
Type of interface	-
Connector	-
Electrically isolated	-
PG/OP channel	-
Number of connections, max.	-
Productive connections	-
Fieldbus	-
<b>Housing</b>	
Material	PPE
Mounting	DIN rail SPEED-Bus
<b>Mechanical data</b>	
Dimensions (WxHxD)	40 mm x 125 mm x 120 mm
Net weight	210 g
Weight including accessories	-
Gross weight	-
<b>Environmental conditions</b>	
Operating temperature	0 °C to 60 °C
Storage temperature	-25 °C to 70 °C
<b>Certifications</b>	
UL certification	yes
KC certification	-

## 5 Deployment

### 5.1 Basics PROFIBUS

#### PROFIBUS-DP

PROFIBUS is an international standard applicable to an open field bus for building, manufacturing used to create a low (sensor-/actuator level) or medium (process level) performance network of programmable logic controllers. PROFIBUS comprises an assortment of compatible versions. The following details refer to PROFIBUS-DP. PROFIBUS-DP is particularly suitable for applications in production automation. DP is very fast, offers Plug'n'Play and is a cost-effective alternative to parallel cabling between PLC and the decentralized periphery. During a single bus cycle the master reads the input values from the various slaves and writes new output information into the slaves.

#### Data transfer medium

PROFIBUS employs screened twisted pair cable on the basis of the RS485 interfaces or a duplex fiber optic link (FO). The data transfer rate of both systems is limited to a max. of 12MBaud.

#### Addressing

Every device on the PROFIBUS is identified by an address. This address must be an unique number in the bus system between 1 ... 124. At the 342-1DA70 the address may be set between 2 ... 124. System dependent the address 1 is reserved.

#### GSD file

To configure the slave connections in your own configuration tool, you've got all the information about your Yaskawa modules in form of an electronic data sheet file. Install this GSD file in you configuration tool. Structure and content of the GSD file are dictated by the PROFIBUS User Organization (PNO) and may be retrieved there. More information about installing the GSD may be found at the online help of the according engineering tool.

## 5.2 Addressing at SPEED-Bus

### Overview

To provide specific addressing of the installed peripheral modules, certain addresses must be allocated in the CPU. With no hardware configuration present, the CPU assigns automatically peripheral I/O addresses during boot procedure depending on the plug-in location amongst others also for plugged modules at the SPEED-Bus.

### Maximal pluggable modules

In the hardware configurator from Siemens up to 8 modules per row may be parameterized. At deployment of SPEED7 CPUs up to 32 modules at the standard bus and 10 further modules at the SPEED-Bus may be controlled. CPs and DP masters that are additionally virtual configured at the standard bus are taken into the sum of 32 modules at the standard bus. For the project engineering of more than 8 modules you may use virtual line interface connections. For this you set in the hardware configurator the module IM 360 from the hardware catalog to slot 3 of your 1. profile rail. Now you may extend your system with up to 3 profile rails by starting each with an IM 361 from Siemens at slot 3.

### Define addresses by hardware configuration

You may access the modules with read res. write accesses to the peripheral bytes or the process image. To define addresses a hardware configuration via a virtual PROFIBUS system by including the SPEEDBUS.GSD may be used. For this, click on the properties of the according module and set the wanted address.

### Automatic addressing

If you do not like to use a hardware configuration, an automatic addressing comes into force. At the automatic address allocation DIOs are mapped depending on the slot location with a distance of 4byte and AIOs, FMs, CPs with a distance of 256byte.

Depending on the slot location the start address from where on the according module is stored in the address range is calculated with the following formulas:

- DIOs: Start address =  $4 \times (\text{slot} - 101) + 128$
- AIOs, FMs, CPs: Start address =  $256 \times (\text{slot} - 101) + 2048$

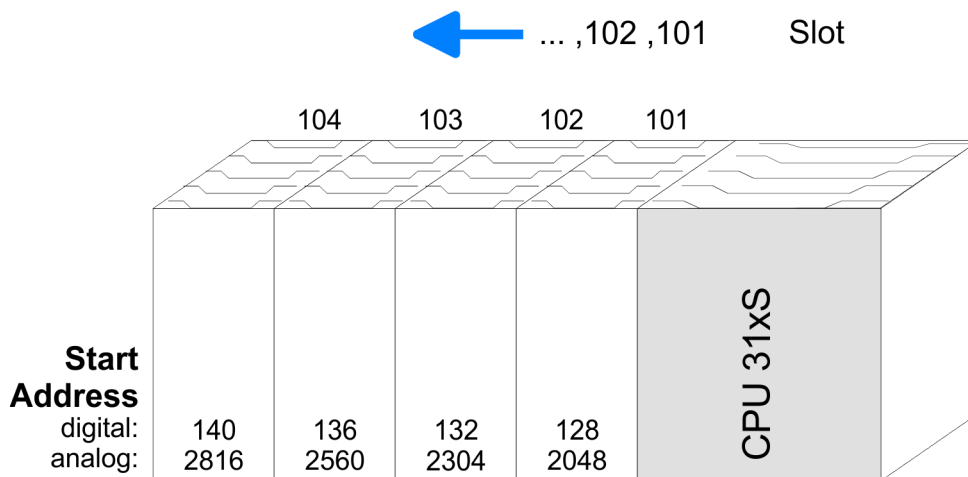

### 5.3 Project engineering

#### Overview

engineering of the DP master at the SPEED-Bus takes place in the hardware configurator from Siemens at the SPEED-Bus section as replacement. The real project engineering is virtual at the standard bus section. For this you virtually configure a CP342-5 (342-5DA02 V5.0) DP master from Siemens. To this master the slave modules may be connected.

#### 5.3.1 Fast introduction

For the deployment of the System 300S modules at the SPEED-Bus, the inclusion of the SPEEDBUS.GSD from Yaskawa in the hardware catalog is required.

To be compatible with the Siemens SIMATIC manager, you have to execute the following steps:

1. Start the hardware configurator from Siemens and include the SPEEDBUS.GSD for SPEED7 from Yaskawa.
2. Configure corresponding CPU from Siemens. Configure a possibly existing internal DP master of your SPEED7-CPU via the internal DP master.
3. Starting with slot 4, place the System 300 modules in the plugged sequence.
4. Project engineering and connection of the SPEED-Bus DP master at the standard bus as virtual CP 342-5 (342-5DA02 V5.0)
5. For the SPEED-Bus you always include, connect and parameterize to the *operating mode* DP master the DP master CP 342-5 (342-5DA02 V5.0) as last module. To this master system you assign every SPEED-Bus module as VIPA\_SPEEDBUS slave. Here the PROFIBUS address corresponds to the slot no. Beginning with 100 for the CPU. Place on slot 0 of every slave the assigned module and alter the parameters if needed.
6. Let with the CPs or DP master (also virtual speed bus master) at *options* the attitude "Save configuration data on the CPU" activated!

#### Standard bus

Slot	Module
1	
2	CPU ...
X...	...
X...	...
3	

real modules at the standard bus

343-1EX11 (PG/OP)

343-1EX11 (only CPU 31xSN)

CPs res. DP master at the SPEED-Bus as 343-1EX11 res. 342-5DA02

342-5DA02 V5.0

virtual DP master for CPU and all SPEED-Bus modules

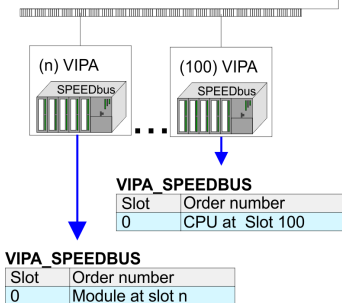

#### 5.3.2 Steps of the project engineering

##### Preconditions

The hardware configurator is part of the Siemens SIMATIC manager and it serves the project engineering. The modules that may configured here are listed in the hardware catalog. For the deployment of the System 300S modules at the SPEED-Bus you have to include the System 300S modules into the hardware catalog via the GSD-file SPEEDBUS.GSD from Yaskawa.



*For the project engineering a thorough knowledge of the Siemens SIMATIC manager and the hardware configurator from Siemens is required!*

**Installation of the SPEEDBUS.GSD**

The GSD (Geräte-Stamm-Datei) is online available in the following language versions. Further language versions are available on inquires:

Name	Language
SPEEDBUS.GSD	German (default)
SPEEDBUS.GSG	German
SPEEDBUS.GSE	English

The GSD files may be found at [www.yaskawa.eu.com](http://www.yaskawa.eu.com) at the service area.

The integration of the SPEEDBUS.GSD takes place with the following proceeding:

1. Go to the service area of [www.yaskawa.eu.com](http://www.yaskawa.eu.com).
2. Load from the download area at 'Config files → PROFIBUS' the according file for your System 300S.
3. Extract the file to your work directory.
4. Start the hardware configurator from Siemens.
5. Close every project.
6. Select 'Options → Install new GSD-file'.
7. Navigate to the directory VIPA\_System\_300S and select **SPEEDBUS.GSD** an.
  - ⇒ The SPEED7 CPUs and modules of the System 300S from Yaskawa may now be found in the hardware catalog at PROFIBUS-DP / Additional field devices / I/O / VIPA\_SPEEDBUS.

**Steps of the project engineering**

The following text describes the approach of the project engineering in the hardware configurator from Siemens at an abstract sample. The project engineering is separated into 3 parts:

- Project engineering of the real plugged modules at the standard bus
- Project engineering of all SPEED-Bus DP master at the standard bus as 342-5DA02 V5.0 from Siemens
- Project engineering of the SPEED-Bus modules in a virtual master system. Here the SPEEDBUS.GSD is necessary.

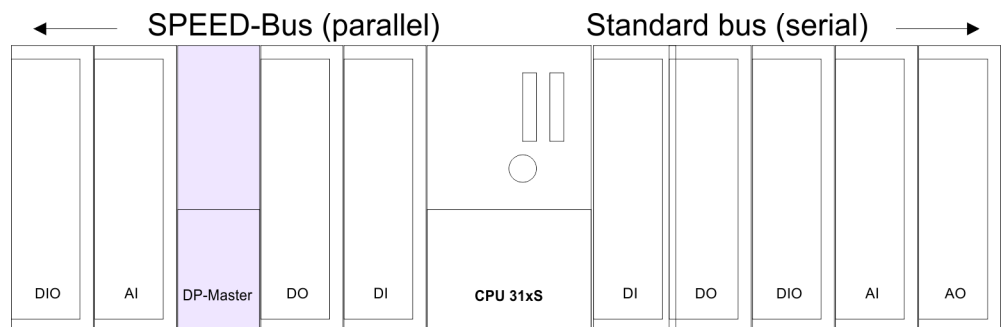

**Project engineering of the modules at the standard bus**

The modules at the right side of the CPU at the standard bus are configured with the following approach:

1. Start the hardware configurator from Siemens with a new project and insert a profile rail from the hardware catalog.
2. Place the corresponding Siemens CPU at slot 2.
3. Include your System 300 modules at the standard bus in the plugged sequence starting with slot 4.
4. Parameterize the CPU res. the modules where appropriate. The parameter window opens by a double click on the according module.
5. Since as many as 32 modules can be addressed by the SPEED7 CPU in one row, but only 8 modules are supported by the Siemens SIMATIC manager, the IM 360 of the hardware catalog can be used as a virtual bus extension during project engineering. Here 3 further extension racks can be virtually connected via the IM 361. Bus extensions are always placed at slot 3.
6. Save your project.

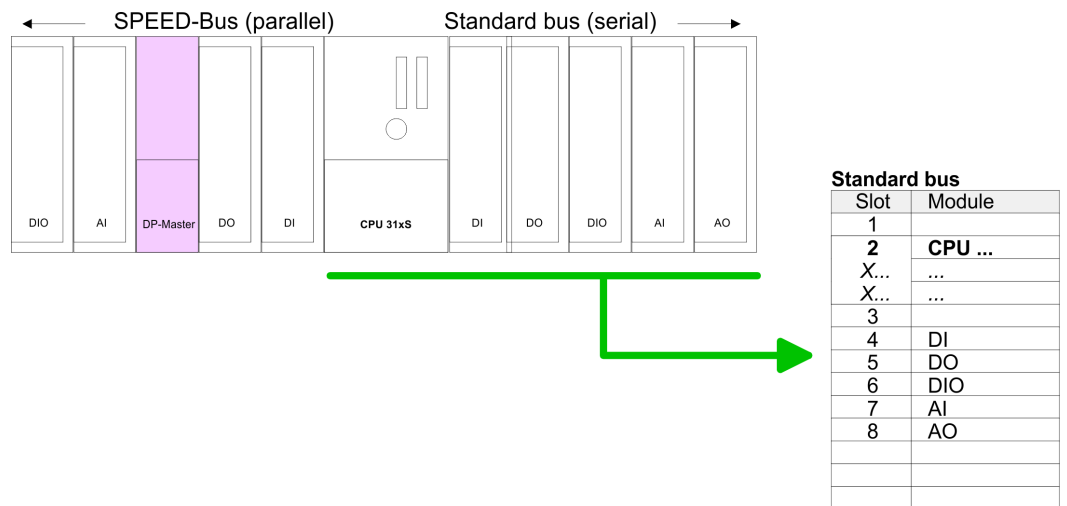

**Project engineering of all SPEED-Bus DP master at the standard bus**

Due to the fact that a SPEED-Bus DP master is in project engineering and parameterization similar to the DP master CP342-5 from Siemens, every SPEED-Bus DP master is inserted at the standard bus as CP342-5 (3425DA02 V5.0) after the already configured modules. The sequence follows the one at the SPEED-Bus from the right to the left. Create a master system for the CP342-5 and include here your PROFIBUS slave systems.

**CAUTION!**

Please take care to not configure ambiguous address assignments at the connection via external PROFIBUS DP master - for the project engineering of SPEED-Bus systems required! The Siemens hardware configurator does not execute an address check for external DP master systems!

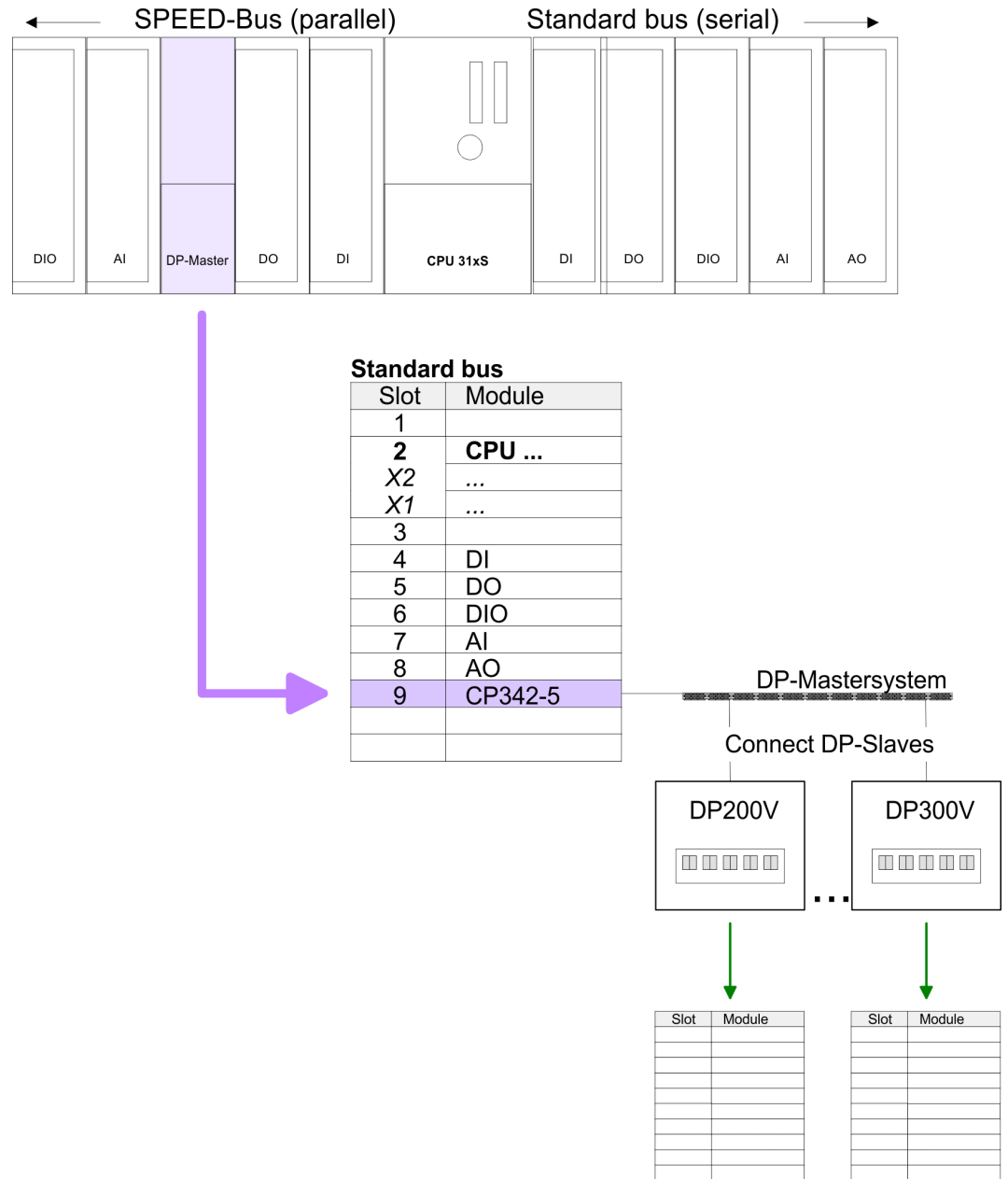

**Project engineering of all SPEED-Bus modules in a virtual master system**

The slot assignment of the SPEED-Bus modules and the parameterization of the in-/output periphery happens via a virtual PROFIBUS DP master system. For this, place as last module a DP master (342-5DA02 V5.0) with master system. For the employment of the System 300S modules at the SPEED-Bus the inclusion of the System 300S modules into the hardware catalog via the GSD-file SPEEDBUS.GSD from Yaskawa is required. After the installation of the SPEEDBUS.GSD you may locate under *Profibus DP / Additional field devices / I/O / VIPA\_SPEEDBUS* the DP slave system *VIPA\_SPEEDBUS*. Now include for the CPU and every module at the SPEED-Bus a slave system "VIPA\_SPEEDBUS". Set as PROFIBUS address the slot no. (100...110) of the module and place the according module from the hardware catalog of *VIPA\_SPEEDBUS* to slot 0 of the slave system.

**SPEEDBUS.GSD**

- 342-1DA70 Master
- 342-1DA70 Master HTB (use SFC 194)



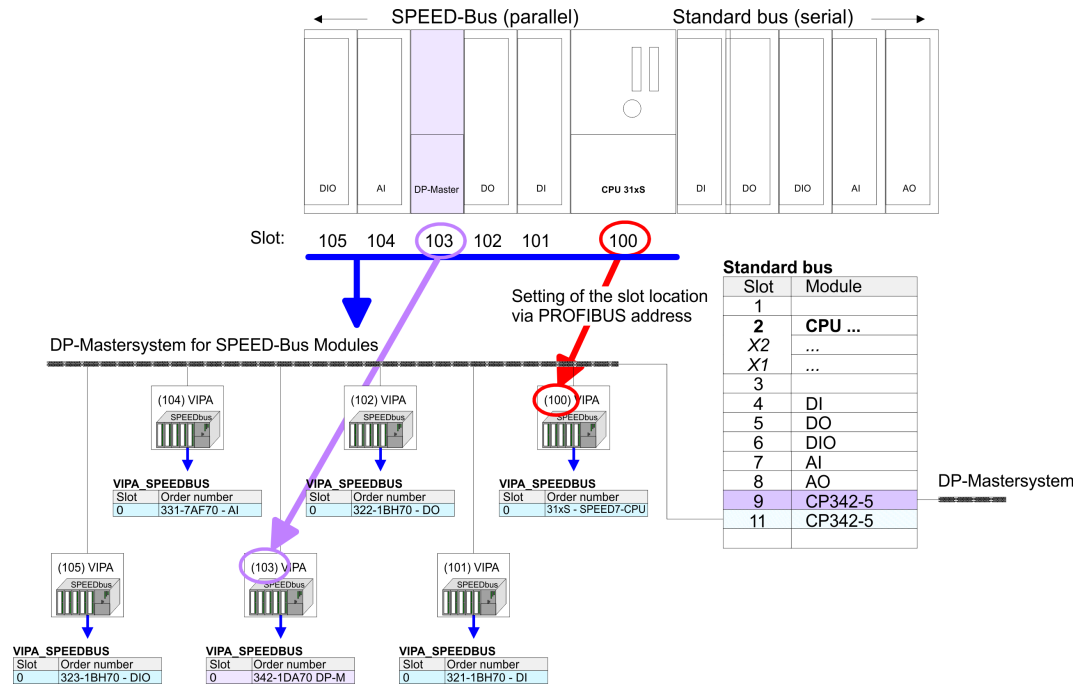

- The according module is to be taken over from the HW Catalog of VIPA\_SPEEDBUS to slot 0.
- Together with your hardware configuration you may transfer your DP master project engineering into the CPU. This passes the project engineering on to the DP master.

Summary

The following illustration summarizes the steps of project engineering:

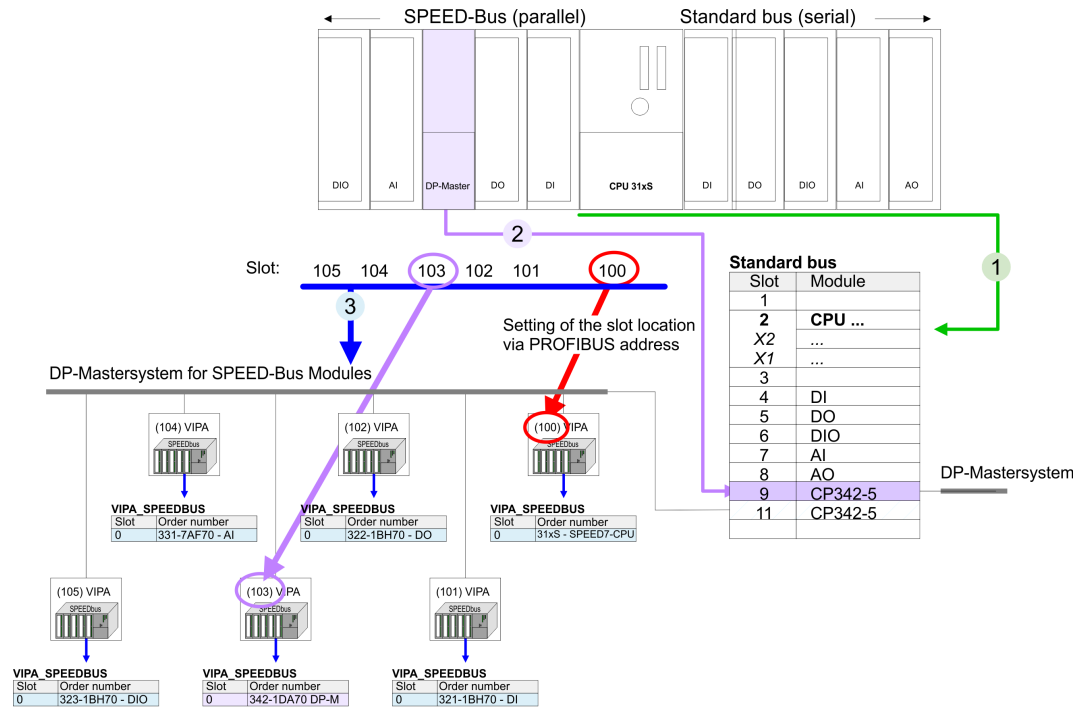

The according module is to be taken over from the HW Catalog of VIPA\_SPEEDBUS to slot 0.

### 5.3.3 Project engineering slave

#### Fast introduction

The deployment of the CP 342-1DA70 as DP Slave exclusively takes place at master systems, which may be projected in the Siemens SIMATIC manager. Apart from project engineering at the SPEED-Bus each Profibus CP is to be projected additionally at the standard bus. Here the slave may be switched to slave operation and connected to PROFIBUS. The I/O communication areas may be set by the SPEED-Bus configuration.

#### Slave system

1. ➤ Start Siemens hardware configurator and install SPEEDBUS.GSD for SPEED7 from Yaskawa.
2. ➤ Configure the corresponding CPU from Siemens.
3. ➤ Starting with slot 4, place the System 300 modules in the plugged sequence.
4. ➤ Project engineering and connection of the SPEED-Bus DP master at the standard bus as Siemens CP 342-5 (342-5DA02 V5.0).
5. ➤ Switch the appropriate DP master to operating mode slave and connect it to PROFIBUS by means of *properties*.
6. ➤ For the SPEED-Bus you always include, connect and parameterize to the *operating mode* DP master the DP master Siemens CP 342-5 (342-5DA02 V5.0) as last module.
7. ➤ To this master system you assign every SPEED-Bus module as VIPA\_SPEEDBUS slave. Here the PROFIBUS address corresponds to the slot no. Beginning with 100 for the CPU.
8. ➤ Place at slot 0 of every slave the assigned module, alter the parameters if needed and set the I/O communication areas of the slave system by *properties*.
9. ➤ Store, translate and transfer the project to the slave system.

#### Master-System

1. ➤ Configure and connect to PROFIBUS an other CPU from Siemens with *operating mode* "DP master".
2. ➤ Choose the DP slave of *Configured stations* (S7-300 CP 342-5 DP V5.0) and connect to the according slave.
3. ➤ Assign the I/O communication areas of the slave system to the I/O address areas of the CPU by placing of byte/word elements within the slave system.
  - ⇒ Here is to be considered:
    - I slave system = O master system
    - O slave system = I master system
4. ➤ Store, translate and transfer the project to the master system.

Let with the CPs or DP master (also virtual speed bus master) at *options* the attitude "Save configuration data on the CPU" activated!

## Project engineering of the slave section

1. Start the Siemens SIMATIC manager with a new project.
2. Insert a SIMATIC 300 station and name it "... slave system".
3. Open the hardware configurator and insert a profile rail from the hardware catalog.
4. Place at slot 2 the corresponding Siemens CPU.
5. Include according to the hardware structure the modules at the standard bus.
6. Configure for the SPEED-Bus DP master in slave operation Siemens CP 342-5 (342-5DA02 V5.0).
7. Switch the DP master to slave operating mode, connect it to PROFIBUS and set a PROFIBUS address > 1 (preferably 3).
8. For the SPEED-Bus you always include the DP master CP 342-5 (342-5DA02 V5.0) from Siemens. Parameterize it to the *operating mode* DP master and connect it with a *new* PROFIBUS net.
9. To this master system you assign every SPEED-Bus module as VIPA\_SPEEDBUS slave. Here the PROFIBUS address corresponds to the slot no. Beginning with 100 for the CPU.
10. Place on slot 0 of every slave the assigned module and alter the parameters if needed.  
342-1DA70 Master  
342-1DA70 Master HTB (use SFC 194)
11. Configure the I/O communication area of the slave system by *means of the properties* of the CP 342-1DA70. Maximally 4 areas may be configured.
12. Save, translate and transfer your project to the CPU of the slave system.

### Slave part

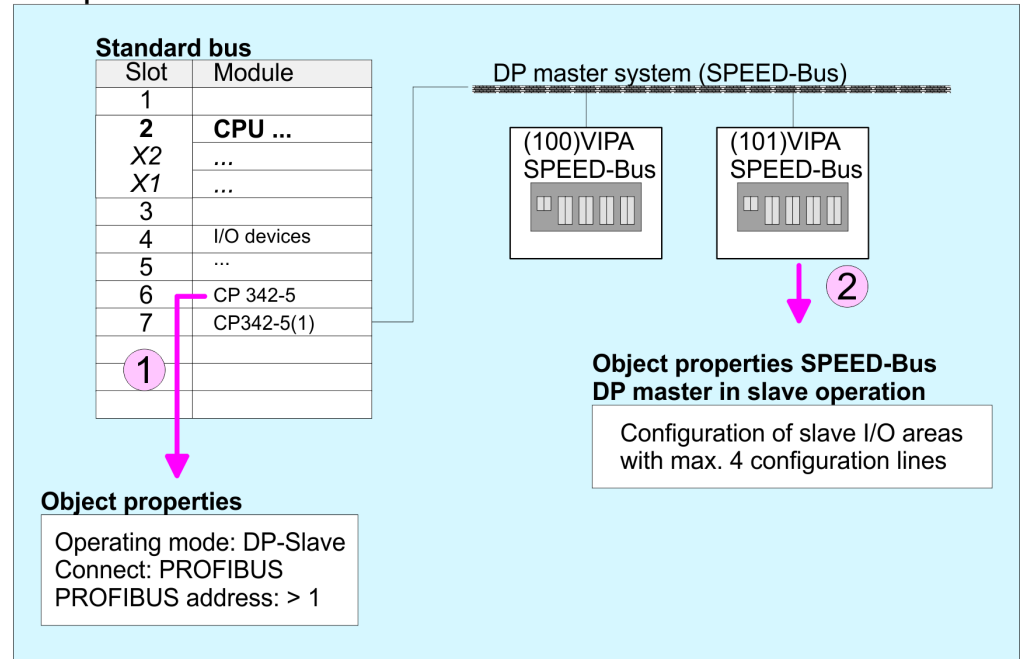

Project engineering of the superimposed master section

1. ➤ Insert another *SIMATIC 300 station* and name it as "... master system".
2. ➤ Open the hardware configurator and insert a profile rail from the hardware catalog.
3. ➤ Place the corresponding Siemens CPU at slot 2.
4. ➤ Add your modules according to the real hardware assembly.
5. ➤ Connect the CPU to PROFIBUS, set a PROFIBUS address >1 (preferably 2) and switch the PROFIBUS section via operating mode to "master operation".
6. ➤ Connect your slave system to the master system by dragging the "S7-300 CP 342-5DA02 V5.0" from the hardware catalog at *configured stations* onto the master system and select your slave system.
7. ➤ Click to the connected slave. Assign the I/O communication areas of the slave system to the I/O address areas of the CPU by placing of byte/word elements within the slave system.
  - ⇒ Here is to be considered:
    - I slave system = O master system
    - O slave system = I master system
8. ➤ Store, translate and transfer the project to the CPU of the master system.

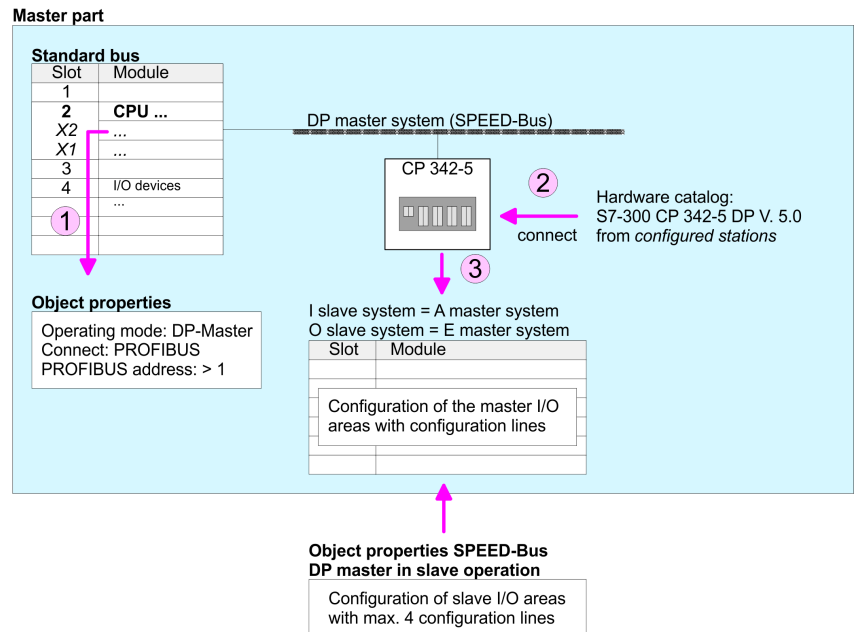

## 5.4 FC/SFC 194 - DP\_EXCH - Data exchange with CP342S

### Description

With the FC/SFC 194 you can exchange data between your CPU and a PROFIBUS DP master, which is connected via SPEED-Bus. Normally each PROFIBUS DP master embeds its I/O area into the peripheral area of the CPU. Here you can address a periphery range of 0 ... 2047 via the hardware configuration. Since this limits the maximum number of PROFIBUS DP master modules at the SPEED-Bus, there is the possibility to deactivate the mapping at the appropriate DP master and to activate instead the access via handling blocks. Here you can write data from the CPU in a defined area of the DP master and read data from a defined area of the DP master.

### Parameters

Parameter	Declaration	Data type	Functionality depending on MODE
LADR	IN	WORD	Base address of the DP master module on the SPEED-Bus
MODE	IN	WORD	Modus (0 = read / 1 = write)
LEN	IN	WORD	Length of the data area in the DP master
OFFSET	IN	DWORD	Begin of the data area in the DP master
RETVAL	OUT	WORD	Return value (0 = OK)
DATA	IN OUT	ANY	Pointer to the data area of the CPU

**LADR** Logical base address of the module.

**MODE** Den FC/SFC 194 may be called with the following modes:

- 0000 = Transfer data from the DP master to the CPU.
- 0001 = Transfer data from the CPU to the DP master.

**LEN** Here the length of the data area in the DP master is defined.

**OFFSET** Here the beginning of the data area in the DP master is defined. Please consider that the area defined via *OFFSET* and *LEN* does not exceed the area defined of the DP master by the hardware configuration.

**RETVAL (Return value)** In addition to the module-specific error codes listed here, as return value there are also general error codes possible for FC/SFCs .

RETVAL	Description
0000h	No error
8001h	<i>LADR</i> could not be assigned to a DP master at the SPEED-Bus.
8002h	The value of the parameter <i>MODE</i> is out of range.
8003h	The value of the parameter <i>LEN</i> is 0.
8004h	The value of the parameter <i>LEN</i> is greater than the data area defined at <i>DATA</i> .
8005h	The area defined by <i>OFFSET</i> and <i>LEN</i> is out of the range 0 ...2047.

---

FC/SFC 194 - DP\_EXCH - Data exchange with CP342S

RETVAL	Description
8006h	The DP master specified by <i>LADR</i> is not configured for access via handling block. Activate in the properties of the DP master "IO-Mode HTB".
8008h	There are gap(s) in the input area.
8009h	There are gap(s) in the output area.
8010h	Error while accessing the input area (e.g. DP master is not reachable)
8011h	Error while accessing the output area (e.g. DP master is not reachable)
8Fxxh	Error at DATA (xx)

## 5.5 PROFIBUS installation guidelines

### PROFIBUS in general

- A PROFIBUS DP network may only be built up in linear structure.
- PROFIBUS DP consists of minimum one segment with at least one master and one slave.
- A master has always been deployed together with a CPU.
- PROFIBUS supports max. 126 participants.
- Per segment a max. of 32 participants is permitted.
- The max. segment length depends on the transfer rate:  
 9.6 ... 187.5bit/s → 1000m  
 500kbit/s → 400m  
 1.5Mbit/s → 200m  
 3 ... 12Mbit/s → 100m
- Max. 10 segments may be built up. The segments are connected via repeaters. Every repeater counts for one participant.
- The bus respectively a segment is to be terminated at both ends.
- All participants are communicating with the same transfer rate. The slaves adjust themselves automatically on the transfer rate.

### Transfer medium

- As transfer medium PROFIBUS uses an isolated twisted-pair cable based upon the RS485 interface.
- The RS485 interface is working with voltage differences. Though it is less irritable from influences than a voltage or a current interface. You are able to configure the network as well linear as in a tree structure.
- Max. 32 participants per segment are permitted. Within a segment the members are linear connected. The segments are connected via repeaters. The maximum segment length depends on the transfer rate.
- PROFIBUS DP uses a transfer rate between 9.6kbit/s and 12Mbit/s, the slaves are following automatically. All participants are communicating with the same transfer rate.
- The bus structure under RS485 allows an easy connection res. disconnection of stations as well as starting the system step by step. Later expansions don't have any influence on stations that are already integrated. The system realizes automatically if one partner had a fail down or is new in the network.

### Bus connection

The following picture illustrates the terminating resistors of the respective start and end station.

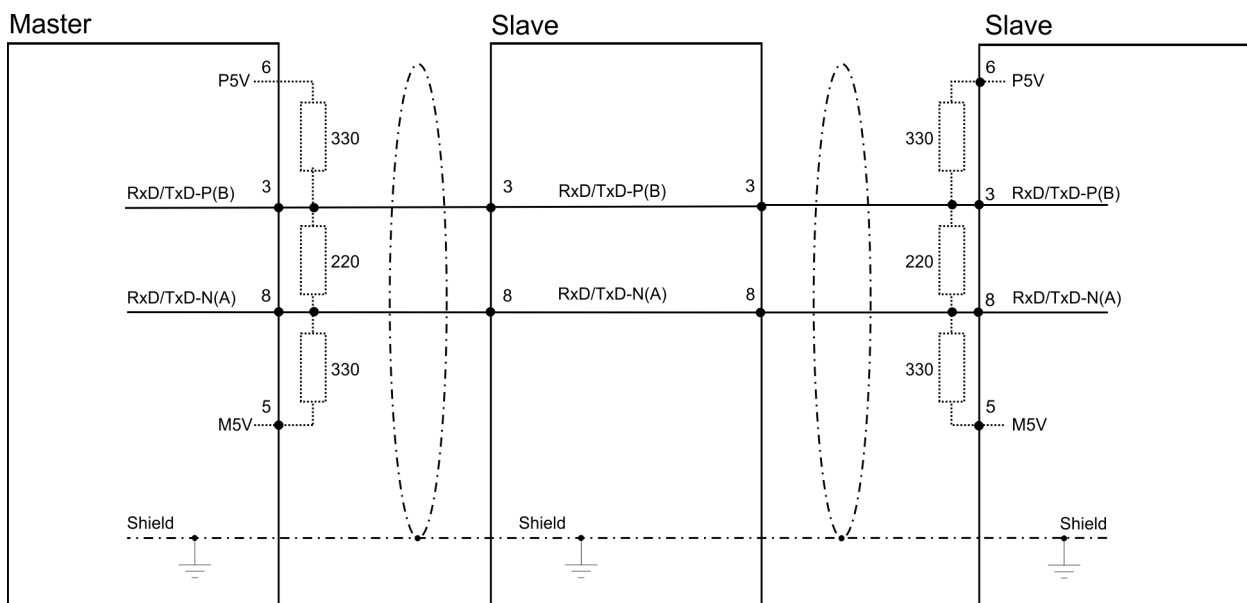



The PROFIBUS line has to be terminated with its ripple resistor. Please make sure to terminate the last participants on the bus at both ends by activating the terminating resistor.

**EasyConn bus connector**



In PROFIBUS all participants are wired parallel. For that purpose, the bus cable must be feed-through. Via the order number 972-0DP10 you may order the bus connector "EasyConn" from Yaskawa. This is a bus connector with switchable terminating resistor and integrated bus diagnostic.

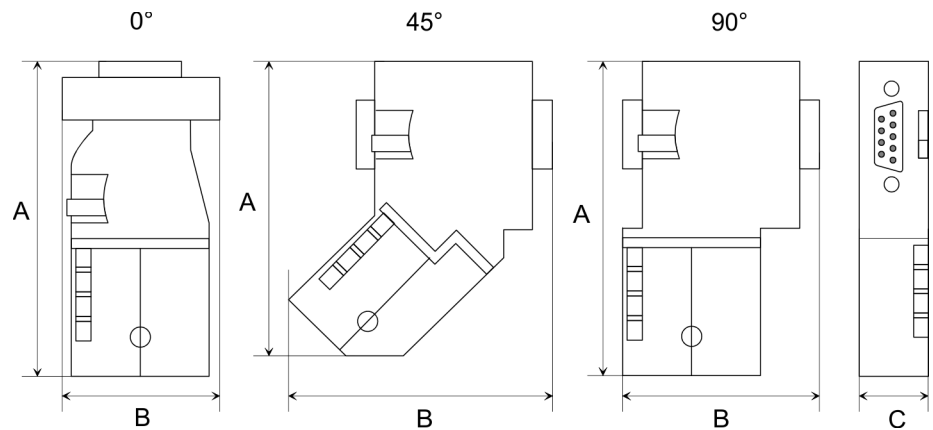

Dimensions in mm	0°	45°	90°
A	64	61	66
B	34	53	40
C	15.8	15.8	15.8



To connect this EasyConn plug, please use the standard PROFIBUS cable type A (EN50170). Starting with release 5 you also can use highly flexible bus cable:

Lapp cable order no: 2170222, 2170822, 2170322.

With the order no. 905-6AA00 Yaskawa offers the "EasyStrip" de-isolating tool that makes the connection of the EasyConn much easier.

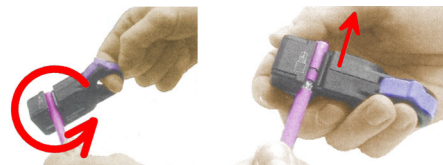
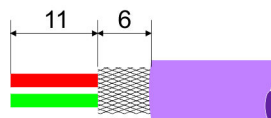

Dimensions in mm

**Termination with "EasyConn"**

The "EasyConn" bus connector is provided with a switch that is used to activate a terminating resistor.



**Wiring**

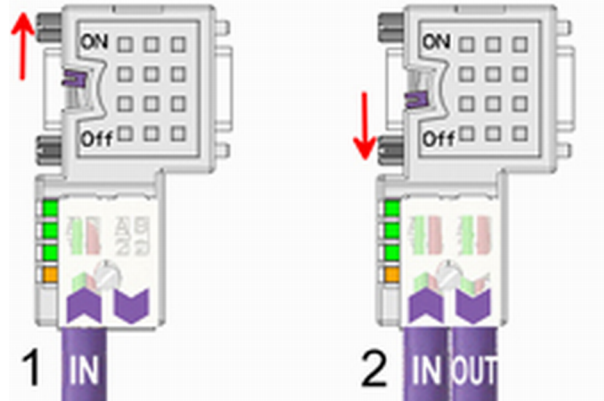

- [1] 1./last bus participant
- [2] further participants



**CAUTION!**

The terminating resistor is only effective, if the connector is installed at a bus participant and the bus participant is connected to a power supply.

The tightening torque of the screws to fix the connector to a device must not exceed 0.02Nm!



*A complete description of installation and deployment of the terminating resistors is delivered with the connector.*

**Assembly**

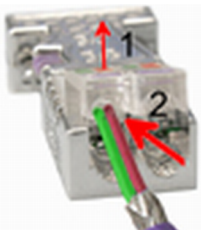

1. Loosen the screw.
2. Lift contact-cover.
3. Insert both wires into the ducts provided (watch for the correct line colour as below!)
4. Please take care not to cause a short circuit between screen and data lines!



5. Close the contact cover.
6. Tighten screw (max. tightening torque 0.08Nm).



*The green line must be connected to A, the red line to B!*